

Robinson & Hall,

Window Fastener.

No. 2,248.

Patented Sept. 11, 1841.

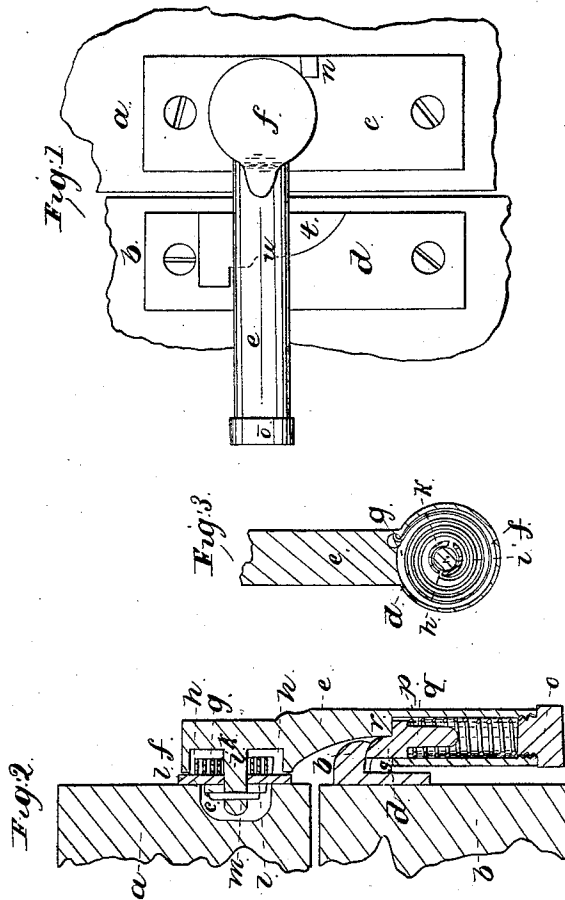

UNITED STATES PATENT OFFICE.

ENOCH ROBINSON AND WM. HALL, OF BOSTON, MASSACHUSETTS.

WINDOW-FASTENING.

Specification of Letters Patent No. 2,248, dated September 11, 1841.

To all whom it may concern:

Be it known that we, ENOCH ROBINSON and WILLIAM HALL, of Boston, in the county of Suffolk and State of Massachusetts, have invented new and useful Improvements in Window-Fastenings, and that the following is a full and exact description of the same.

The said description, taken in connection with the accompanying drawings hereinafter referred to, composes our specification, setting forth the principles of our said invention by which it may be distinguished from others of a similar character, together with such parts or combinations as we claim and for which we solicit an exclusive property to be secured to us for fourteen years by Letters Patent.

The figures of the accompanying plate of drawings represent our improvements.

Figure 1, is a plan of the apparatus attached to the sashes of a window, Fig. 2, being a vertical cross section and Fig. 3, a horizontal section of a portion of the same.

The great objections to window fastenings now in use are, that when, by shrinking or other causes, the crack or space, between the bottom of the upper and top of the lower sash (when they are together), becomes enlarged, the bolt or button binds on the catch, and so much so that at times, as to render it impossible to fasten them; and also, when this crack or opening is diminished, or the sashes fit more closely than when the apparatus was first applied, there will be a space for the play of the sashes, and when the wind is high a boisterous rattling or vibration will be produced which is a serious annoyance.

These imperfections are effectually remedied by our improvements as will be apparent, from the following description.

a, b, Figs. 1 and 2, represent the sashes. *c, d*, are rectangular metallic plates attached respectively to the sashes *a, b*, and confined by screws or otherwise. *e* is the turning or lever button, shaped as seen in plan and section in Figs. 1 and 2 and having a vertical cylinder *f* at one end in the circular space *g*, of which a coiled spring *h, h*, is arranged around the central pin or shaft *i*. This shaft passes through a cylindrical projection, *k*, from the plate *c*, and in connection with the collar *l* and pin *m*, arranged as seen in Fig. 2, serves to confine the lever button *e* to said plate in such manner as to permit it to turn freely around in either direction.

One end of the coiled spring (which is bent for the purpose), fits into a groove or notch in the side of the vertical cylinder *f*, while the other end, which is likewise bent engages with a slot or groove in the cylindrical projection *k* from the plate, *c*, which is of course kept stationary with said plate, and when the other end is turned with the button the elasticity of the coiled spring is increased and unless the button, it would be carried, by the action of the spring, against the stud or projection *n* from the plate, *c*. The other or fastening end of the button *e* is a hollow horizontal cylinder closed at one end by the screw stopper *o*, against the inner end of which, one end of a spiral spring *p, p*, rests, the other end abutting against the inside of the head of the loose pin *q*, which is kept in position by a notch *r* in the button *e* as seen in Fig. 2, against which a part of the head of the loose pin rests. The other part of said head has a right angular projection *s* the end of which is so rounded as to move easily on the curved face of the catch *t*, in the notch *u* of which it rests when the window is fastened. The catch *t*, as will be perceived by the drawings, is attached to or cast solid with the plate *d*.

From the above described arrangement of the spiral spring, &c., it will be palpable that the window fastening will operate with facility however much the sashes may be shrunk or otherwise changed after the fastening is first applied, and that any jarring or rattling of the sashes when fastened will be effectually remedied.

Having thus described our improvements we shall claim as our invention—

Constructing the fastening end of the lever or turning button, of a horizontal hollow cylinder closed at one end by a screw stopper or otherwise, and arranging in said cylinder a spiral or helical spring and loose pin, the whole being constructed, and operating together substantially in manner, and for the purpose above described.

In testimony that the foregoing is a true description of our said invention and improvements we have hereto set our signatures this thirteenth day of June in the year eighteen hundred and forty one.

ENOCH ROBINSON.
WM. HALL.

Witnesses:

R. H. EDDY,
EZRA LINCOLN.