

(No Model.)

H. F. GAINES.
BUNG.

Patented Jan. 31, 1882.

No. 252,937.

Fig. 1.

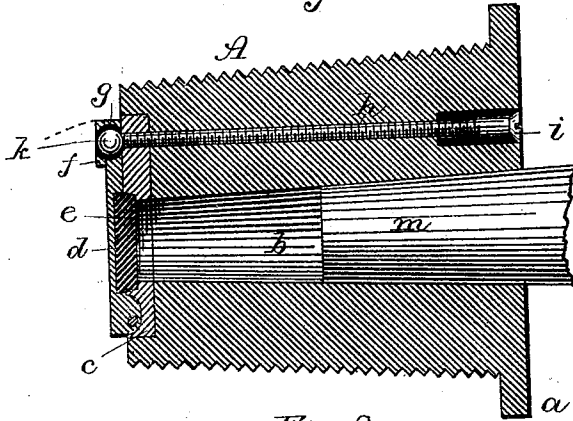

Fig. 2.

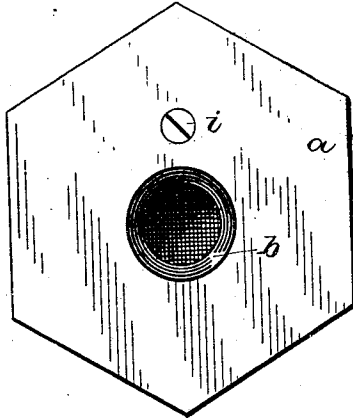
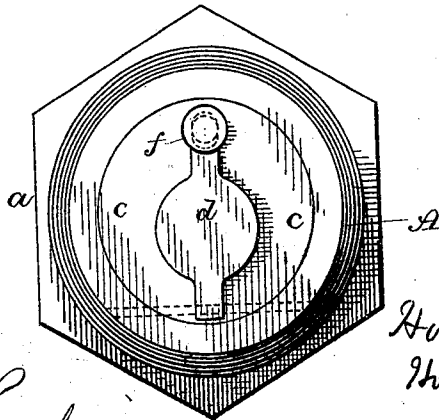

Fig. 3.



Witnesses:

J. W. Garner
C. M. Osgood

Inventor:
Hiram D. Gaines.
Howard A. Snow
Attorney.

UNITED STATES PATENT OFFICE.

HIRAM F. GAINES, OF ROUSE'S POINT, NEW YORK.

BUNG.

SPECIFICATION forming part of Letters Patent No. 252,937, dated January 31, 1882.

Application filed August 25, 1881. (No model.)

To all whom it may concern:

Be it known that I, HIRAM F. GAINES, a citizen of the United States of America, residing at Rouse's Point, in the county of Clinton and State of New York, have invented certain new and useful Improvements in Bungs; and I do hereby declare the following to be a full, clear, and exact description of the invention, such as will enable others skilled in the art to which it appertains to make and use the same, reference being had to the accompanying drawings, and to letters or figures of reference marked thereon, which form a part of this specification.

My invention relates to bungs; and it consists of the construction and arrangement of the several parts, as will be hereinafter set forth.

In the drawings, which fully illustrate my invention, Figure 1 is a longitudinal section; Fig. 2, a view of the outer end, and Fig. 3 a view of the inner end.

A is the bung. It is provided with a hexagon shoulder, *a*, by which it is screwed into the barrel, and a beveled hole, *b*, placed slightly away from the center of the bung, as shown. Placed in a recess in its inner end is the bushing *c*, having hinged to it the valve *d*. Let into the valve-face is the rubber packing *e*, which enters a groove in the bushing *c*, and with it forms a water-tight joint. Situated on the opposite side of the valve from the hinge

is a cap, *f*, fitting over the socket *g*, as shown. Through the bung is the threaded hole *h*, in which operates the valve-screw *i*. The hole is made larger on its outer end to accommodate the head of the screw, as shown. Upon the inner end of the screw *i* is the ball *k*, which is inclosed in the socket *g* and affords attachment for the screw to the valve. The socket is made slightly elongated, as shown, and permits the valve to open wider than would a socket closely fitting the ball.

m represents the end of a faucet driven into the hole of the bung.

In the operation of this device the faucet is driven firmly into the bung, as shown, a screw-driver is then placed in the slot in the screw *i*, and the valve *d* opened, the liquid of course flowing in. When the barrel is empty, or it is desired to remove the faucet, the valve can be closed and the faucet knocked out.

What I claim as my invention, and desire to secure by Letters Patent, is—

The bung *A*, provided with a faucet-hole, *b*, in combination with the hinged valve *d*, bushing *c*, and valve-operating screw *i*, substantially as shown.

In testimony whereof I affix my signature in presence of two witnesses.

HIRAM F. GAINES.

Witnesses:

W. J. OSGOOD,
F. P. SNOW.