



(12) **EUROPEAN PATENT APPLICATION**

(43) Date of publication:
09.02.2000 Bulletin 2000/06

(51) Int. Cl.⁷: **G03G 15/34, G03G 15/08**

(21) Application number: **98202607.2**

(22) Date of filing: **03.08.1998**

(84) Designated Contracting States:
**AT BE CH CY DE DK ES FI FR GB GR IE IT LI LU
MC NL PT SE**
Designated Extension States:
AL LT LV MK RO SI

• **Desie, Guido,**
**Agfa-Gevaert N.V., IIE 3811
2640 Mortsel (BE)**
• **Vandenwynaert, Hilbrand,**
**Agfa-Gevaert, IIE 3811
2640 Mortsel (BE)**
• **Leonard, Jacques,**
**Agfa Gevaert N.V., IIE 3811
2640 Mortsel (BE)**

(71) Applicant: **AGFA-GEVAERT N.V.**
2640 Mortsel (BE)

(72) Inventors:
• **Bourbon, Peter,**
**c/o Agfa Gevaert N.V. IIE 3811
2640 Mortsel (BE)**

(54) **A method of printing in a device for direct electrostatic printing comprising a toner delivery means that comprises a charged toner conveying roll, a magnetic brush and a cleaning unit**

(57) A method for Direct Electrostatic Printing (DEP) is provided comprising the steps of :

- bringing charged toner particles from a magnetic brush carrying magnetic carrier particles and non magnetic toner particles to a toner bearing surface of a conveyer for charged toner,
- applying an electrical potential difference between the toner bearing surface and an image receiving member, for creating a flow of charged toner particles from the surface bearing charged toner particles to the image receiving member,
- placing a printhead structure having printing apertures and control electrodes in the flow, forming a development zone under the printing apertures for image wise depositing toner particles, from the flow of charged toner particles, on the image receiving member
- moving the conveyer for charged toner particles to pass the toner bearing surface repeatedly through the development zone, in a direction so as to have the magnetic brush upstream of the development zone and
- removing, downstream from the development zone, non-used toner particles from the toner bearing surface and collecting them.

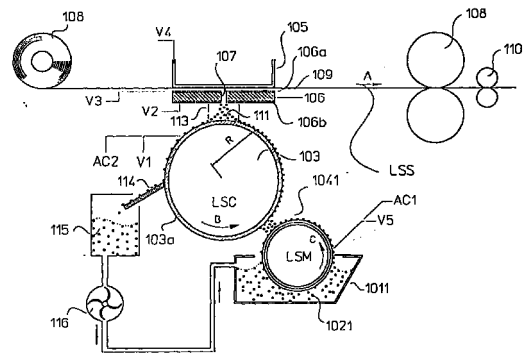

Fig. 2

Description

FIELD OF THE INVENTION

5 **[0001]** This invention relates to a recording method and an apparatus for use in the process of Direct Electrostatic Printing (DEP), in which an image is created upon a receiving substrate by creating a flow of toner particles from a toner bearing surface to the image receiving substrate and image-wise modulating the flow of toner particles by means of an electronically addressable printhead structure.

10 BACKGROUND OF THE INVENTION

[0002] In DEP (Direct Electrostatic Printing) toner particles are deposited directly in an image-wise way on a receiving substrate, the latter not bearing any image-wise latent electrostatic image.

15 **[0003]** This makes the method different from classical electrography, in which a latent electrostatic image on a charge retentive surface is developed by a suitable material to make the latent image visible, or from electrophotography in which an additional step and additional member is introduced to create the latent electrostatic image (photoconductor and charging/exposure cycle).

[0004] A DEP device is disclosed in e.g. **US-A-3 689 935**. This document discloses an electrostatic line printer having a multi-layered particle modulator or printhead structure comprising :

- 20
- a layer of insulating material, called isolation layer ;
 - a shield electrode consisting of a continuous layer of conductive material on one side of the isolation layer ;
 - a plurality of control electrodes formed by a segmented layer of conductive material on the other side of the isolation layer ; and
- 25 - at least one row of apertures.

[0005] Each control electrode is formed around one aperture and is isolated from each other control electrode.

[0006] Selected electric potentials are applied to each of the control electrodes while a fixed potential is applied to the shield electrode. An overall applied propulsion field between a toner delivery means and a support for a toner receiving substrate projects charged toner particles through a row of apertures of the printhead structure. The intensity of the particle stream is modulated according to the pattern of potentials applied to the control electrodes. The modulated stream of charged particles impinges upon a receiving substrate, interposed in the modulated particle stream. The receiving substrate is transported in a direction perpendicular to the printhead structure, to provide a line-by-line scan printing. The shield electrode may face the toner delivery means and the control electrodes may face the receiving substrate. A DC-field is applied between the printhead structure and a single back electrode on the receiving substrate. This propulsion field is responsible for the attraction of toner to the receiving substrate that is placed between the printhead structure and the back electrode.

30 **[0007]** One of the problems with this type of printing devices is that charged toner particles can accumulate upon the printhead structure and in the printing apertures. Due to this problem the achievable printing density does not remain constant in the time, while the charged toner particles accumulated on the printhead structure may change the electrical field wherein the charged toner particles are propelled towards the substrate and the toner particles accumulated in the printing apertures can physically block the toner passage.

[0008] Several disclosures concerning devices that can clean up a printhead structure after it has been smudged with toner particles are known in the art.

45 **[0009]** In other disclosures, ways and means are disclosed to prevent the smudging of the printhead structure in the first place.). In, e.g., **US-A-4 755 837** and **US-A-4 814 796** it is disclosed that the presence of Wrong Sign Toner (WST) is the main cause of accumulation of toner particles upon said printhead structure and in the printing apertures. Wrong sign toner particles are particles that have a sign different from that of the majority of the particles. Therefore they respond to the applied electrical fields for creating a flow of charged toner particles to the substrate in an opposite way than the majority of the toner particles. In these disclosures it has been described that the problem of wrong signed toner can be solved when in a device for direct electrostatic printing the flow of toner particles towards the substrate originates from the surface of a conveyer for charged toner particles (hereinafter indicated as "charged toner conveyer of CTC) whereon well behaved (i.e. wherein no wrong sign toner is present) charged toner particles are deposited by using a magnetic brush comprising two-component developer.

55 **[0010]** An other way to avoid the presence of wrong signed toner is to use a magnetic brush with two-component developer in which the toner particles are charged to a high charge-to-mass ratio ($\mu\text{C/g}$) for bringing charged toner particles to the surface of the CTC. However, a high charge-to-mass ratio leads to a high sticking force of charged particles to electrode surfaces of opposite polarity so that printing at high speed with sufficient density becomes problematic. It

is, e.g. indicated in **EP-A-811 894** that a higher charge-to-mass ratio can also lead to an unevenness in image parts of maximum and moderate density.

5 **[0011]** In **US-A-5 040 004** a moving belt is introduced as toner application module, said moving belt sliding over an accurately positioned shoe that is placed at close distance from said printhead structure. Charged toner particles are applied towards said moving belt from a magnetic brush comprising two-component developer. With this design the distance, and as a consequence also the propulsion field, can be finely tuned to be equal for all rows of printing apertures. Also the running position of the moving belt can be set so that unused toner particles can come in contact with the developing material in the toner supply part of the magnetic brush. This solution to uneven printing, however, need mechanically very accurate and expensive means to be used so as to fabricate the toner application module. Moreover, 10 solution wherein sliding contact between parts are necessary, are often not well suited for excellent long term stability and reliability, due to possible wear of the sliding parts.

[0012] In **US-A-5 337 124** and **EP-A-740 224** a toner application module for electrophotographic and electrographic printing has been described in which two different magnetic brushes are used, one to supply toner particles to a charged toner conveying roller and one recuperate them from said roller. This is a system wherein a pushing magnetic brush brings the toner particles to the surface of the CTC and after the surface of the CTC has passed near the printing 15 apertures a pulling magnetic brush is used to clean the surface of the CTC. An idea similar to the one disclosed in **US-A-5 337 124** and **EP-A-740 224** has been disclosed in **DE-A-197 45 561** for non-magnetic mono component development systems in which the toner bearing roller structure also is fed by and cleaned from toner particles.

20 **[0013]** However, in all of these prior art applicator designs, the long term stability of the charge-to-mass ratio during the complete printing process is not easily achieved. Thus there is still a need for further improved DEP devices making it possible to print at elevated speed with no or very low toner accumulation upon said printhead structure and with a reliable and constant flow of well behaved charged toner particles from said toner application module.

OBJECTS AND SUMMARY OF THE INVENTION

25 **[0014]** It is an object of the invention to provide a method for direct electrostatic printing wherein high speed printing is achieved with low clogging of the printing apertures wherein high maximum density is reached and that makes it possible to print with a printing quality that is constant over a long period of time.

30 **[0015]** A further object of the invention is to provide a DEP device, i.e. a device for direct electrostatic printing that can print at high speed with low clogging of the printing apertures and with high and constant maximum density and with constant grey level density over a long period of time.

[0016] Further objects and advantages of the invention will become clear from the detailed description herein after.

[0017] The object of the invention is realised by providing a method for Direct Electrostatic Printing (DEP) is provided comprising the steps of:

- 35
- bringing charged toner particles from a means for delivering non magnetic toner particles to a toner bearing surface of a conveyer for charged toner,
 - applying an electrical potential difference between said toner bearing surface and an image receiving member, for creating a flow of charged toner particles from said surface bearing charged toner particles to an image receiving 40 member,
 - placing a printhead structure having printing apertures and control electrodes in said flow, forming a development zone under said printing apertures for image wise depositing toner particles, from said flow of charged toner particles, on said image receiving member
 - moving said conveyer for charged toner particles to pass the toner bearing surface repeatedly through said development zone, in a direction so as to have said magnetic brush upstream of the development zone and 45
 - removing and collecting, downstream from said development zone, non-used toner particles from said toner bearing surface.

50 **[0018]** In a preferred embodiment said cleaning means is a scraper blade that removes non-used toner from said charged toner conveyer. In a further preferred embodiment the removed non-used toner particles are recycled to the developer supply of said magnetic brush assembly.

BRIEF DESCRIPTION OF THE DRAWINGS

55 **[0019]**

Figure 1 shows schematically a development zone in a DEP device for use in a method according to the present invention.

Figure 2 shows schematically a DEP device according to the present invention for use with non-magnetic mono-component developer.

Figure 3 shows schematically a DEP device according to the present invention for use with two-component developer comprising non-magnetic toner particles and magnetic carrier particles.

5

DETAILED DESCRIPTION OF THE INVENTION

Definitions

10 **[0020]** The term CTC "charged toner conveyer" is used for a conveyer of charged toner particles rotated in one direction, said charged toner particles being applied to it by means of a magnetic brush or a non-magnetic mono-component toner charging member

15 - "reference surface of the magnetic brush" is the surface of the sleeve of the magnetic brush when NO developer is present on said magnetic brush.

20 - "development zone" is the volume between the printhead structure (106) and the toner bearing surface (103a) of the charged toner conveyer (103), wherein the toner cloud (111) is formed. In Fig. 1, a non-limitative example of a development zone is given. It is the zone (volume) (113) between the printhead structure (106) and the toner bearing surface (103a), determined by the surface of said printhead structure (106) facing said toner bearing surface, and the perpendicular planes dropping from the edges of the array of printing apertures (107) to said toner bearing surface and said surface itself (112) within the volume determined by said perpendicular planes. In figures 2 and 3, the development zone, the CTC, the printhead structure and the printing apertures are shown in cross-section along the plane A, A' and A".

25 **[0021]** It is known in the art of DEP (direct electrostatic printing), that toner accumulation on the printhead structure and in the printing apertures can partially or completely block said printing apertures, leading to white stripes of missing dots. Adherence of a tiny amount of charged toner particles can also influence the shape of the electrical field lines in the neighbourhood of said printing apertures which again can lead to deformation of the resultant toner flux, so that irregularities in image density result.

30 **[0022]** It has been found that the problem of time dependent fluctuations in image density and image evenness which was could be solved by removing the non-used charged toner particles from the toner bearing surface of the charged toner conveyer downstream of the development zone and providing it with fresh toner upstream of the development zone. Thus the method of the invention involves that the flow of charged toner particles is created from the toner bearing surface of a charged toner conveyer (CTC). On said surface a population of charged toner particles, wherein no wrong sign toner particles are present, is provided. Said population of charged toner particles, wherein no wrong sign toner particles are present can be generated in a non-magnetic mono-component toner container and applied from said container over, e.g., a roller to the surface of the CTC or in a magnetic brush assembly with magnetic carrier particles and non-magnetic toner particles and applied from the hairs of the magnetic brush to the surface of the CTC. In the method of this invention it is preferred to generate the population of charged toner particles, wherein no wrong sign toner particles are present, in a magnetic brush assembly, with a non-magnetic sleeve and a magnetic core, that provides said charged toner particles to the surface of a CTC by lumping them over the gap between said the sleeve and said surface of the CTC by means of a DC-field and/or an AC-field. By moving the surface of the CTC near the printhead structure, said charged toner particles are brought in the development zone, wherein a flow of toner particles towards an image receiving member to be printed is created by applying an electrical potential difference between the toner bearing surface of the CTC and the image receiving member. By image-wise opening or closing printing apertures in a printhead structure placed in the flow of toner particles, part of said charged toner particles are image-wise brought to the image receiving member. The remaining charged toner particles are further displaced downstream or the printing zone to a cleaning station in which a complete removal of charged (or discharged) toner particles from the surface of said CTC to have a bare surface again. Then the CTC moves further on towards the magnetic brush or non-magnetic mono-component dispenser, located upstream of the development zone where again a fresh population of charged toner particles, wherein no wrong sign toner particles are present, is provided on the surface of the CTC.

45 **[0023]** The toner particles are removed by means of a scraper blade, a rotating brush, a roller with a surface of foamed polymers, a suction device, etc. Preferably, in a method according to this invention, the non-used toner particles are removed from the toner bearing surface of the CTC with a scraper blade, which can be made from a plastic material or of metal. In a method according to this invention it is preferred to use scraper blade made of stainless steel. Surprisingly it was found that cleaning of the CTC by using a pulling magnetic brush downstream the development zone did not give the possibility of long time printing of images with constant image density and evenness. Especially when a method of direct electrostatic printing is used for large format printing in which large areas of paper have to be printed upon and

55

later on combined in a poster assembly, the image quality reached with the method of this invention using mechanical cleaning means, e.g., a scraper blade, a rotating brush, a roller with a surface of foamed polymers, a suction device, etc., was better than with methods wherein a pulling magnetic brush was used upstream the development zone.

5 **[0024]** In a preferred embodiment of the invention, the non-used toner particles that have been removed from the CTC are recycled in the magnetic brush or in the container and dispenser of non-magnetic mono-component developer. When the toner particles are recycled in the magnetic brush, it is preferred to mix said toner first with carrier particles so that said toner particles are recycled in the magnetic brush as a two component developer. The carrier particles used for mixing with the removed non-used toner particles can be fresh carrier particles as well as carrier particles originating from the original developer after depletion (complete or partial) of the two component developer or toner particles during
10 printing.

[0025] It is preferred in the method of this invention not-only to prevent the use of wrong sign toner, but also to use toner particles with a narrow charge distribution is narrow, i.e. the charge of the toner particles shows a distribution wherein the coefficient of variability (v), i.e. the ratio of the standard deviation to the average value, is equal to or lower than 0.4 preferably lower than 0.3. The charge distribution of the toner particles is measured by an apparatus sold by
15 Dr. R. Epping PES-Laboratorium D-8056 Neufahrn, Germany under the name "q-meter. In, e.g., US-A-5 569 567, US-A-5 622 803 and US-A-5 532 097 it is disclosed how to prepare both negatively and positively chargeable toner particles with narrow charge distribution. It is a preferred embodiment of the invention to use toner particles prepared according to the method described in these disclosures.

[0026] The invention also encompasses a device for direct electrostatic printing comprising :

- 20
- in a container (101, 1011), containing toner particles (102a, 1021) a means (104, 1041) for bringing charged non-magnetic toner particles to a toner bearing surface (103a) of a conveyer for charged toner (103),
 - one or more voltage sources ($V1$, $V4$) for applying an electrical potential difference between said toner bearing surface and an image receiving member (109), for creating a flow (111) of charged toner particles from said surface
25 bearing charged toner particles to said image receiving member,
 - a printhead structure (106) having printing apertures (107) and control electrodes (106a) placed in said flow, forming a development zone (113) under said printing apertures for image wise depositing toner particles, from said flow of charged toner particles, on said image receiving member
 - a means (not shown) for moving said conveyer for charged toner particles, in a direction of arrow B, to pass said
30 toner bearing surface repeatedly through said development zone so as to have said means for bringing charged toner particles on said surface upstream of the development zone and
 - a means for removing (114) and collecting (115), placed downstream from said development zone, non-used toner particles from said toner bearing surface.

35 **[0027]** In a first implementation of a DEP device according to this invention, said means for bringing toner particles to the surface (103a) comprise in a container (1011) a dispenser (1041) for non-magnetic mono component developer (1021) as shown in figure 2.

[0028] In a preferred embodiment of said first implementation of a device according to this invention it further comprises means (116) incorporating a pumping system for recycling said removed non-used toner particles in said container (1011) for repeated use.
40

[0029] In a second implementation, which is the preferred one and is shown in figure 3, of a DEP device according to this invention, said means for bringing charged non-magnetic toner particles to said toner bearing surface comprises in a container (101) a two-component developer (102) with magnetic carrier particles (102b) and non-magnetic toner particles (102a) and a magnetic brush (104) with a sleeve (104b) arranged around a magnetic core (104a). Said sleeve is
45 connected to a DC voltage source ($V5$) so as to apply an electrical potential difference between said sleeve and said toner bearing surface connected to a DC voltage source ($V1$). This potential difference makes the toner particles jump from said sleeve to said surface (103a) of said toner conveyer(103).

[0030] In said second implementation of a DEP device according to this invention the non-used toner particles can simply be recycled by recycling means (116, 121) with pumping systems to said container (101).

50 **[0031]** It is preferred in this second implementation that the recycling means further comprises mixing means (117) for mixing the removed toner particles with fresh toner particles contained in a container (119) which may be coupled to the mixing means (117) and recycled in to said container (101) with a magnetic brush (104). It is even more beneficial that the removed toner particles are mixed not only with fresh toner particles but also with fresh carrier particles from a container (118) that can be coupled to said mixing means (117). In this case the removed non-used toner particles are
55 recycled to said magnetic brush as part of a two-component developer.

[0032] In a further preferred embodiment of said second implementation, the device comprises further means (120) for bringing (used) developer from the container (101) to the mixing means (117). In this mixing means, the removed non-used toner particles are not only mixed with fresh carrier particles and/or fresh toner particles but also with (used)

developer. Also in this case the non-used toner particles are recycled to said magnetic brush as part of a two-component developer.

[0033] In another embodiment said means (115) and collecting the non-used toner particles can be equipped for mixing said toner particles with fresh carrier particles, fresh toner particles and/or used developer so that the special mixing means (117) can be omitted.

Description of the DEP device

[0034] A non limitative example of a device for implementing a DEP method according to this invention using non-magnetic mono-component developer is shown in fig 2. It comprises :

(i) a means for bringing non magnetic charged toner particles to the surface (103a) of a charged toner conveyer, comprising a container (1011) for non-magnetic mono component developer (1021) and a dispensing (1041) roller. The surface of said dispensing roller is equipped with a means (not shown in the figure) for rotating it, in the direction of arrow C so that the surface of it has a linear speed LSM. Said surface is coupled to a DC-voltage source V5 and an AC-voltage source AC1 for jumping charged toner particles upon the surface (103a) said charged toner conveyer (103) from said non-magnetic mono-component developer. The charged toner conveyer (103) is equipped with a means (not shown in the figure) for rotating said it, in the direction of arrow B, which is opposite to the direction of rotation of the surface of the dispensing roller, so that the toner bearing surface (103a) of it has a linear speed LSC. The CTC is rotated so that the charged toner particles on its surface are brought in the development zone (113), the dispensing roller (1041) is located upstream of the development zone.

(ii) a back electrode (105) coupled to a DC-voltage source V4, for maintaining said back electrode at a voltage different from the voltage (V1) applied to the surface of the CTC, for forming an electrical propulsion field wherein a flow (111) of charged toner particles is created from the surface of the CTC towards the back electrode.

(iii) a printhead structure (106), made from a plastic insulating film, coated on both sides with a metallic film. The printhead structure (106) comprises one continuous electrode surface, hereinafter called "shield electrode (106b) coupled to a voltage source V2 facing in the shown embodiment the CTC and a complex addressable electrode structure, hereinafter called "control electrode" (106a) around printing apertures (107) and coupled to a variable voltage V3. Said printhead structure is placed in said flow of toner particles so that by applying a varying voltage V3 to the control electrode the flow of toner particles towards the back electrode can be image-wise modulated in the development zone (113). Said printing apertures are arranged in an array structure for which the total number of rows can be chosen according to the field of application.

(iv) conveyer means (108) to convey an image receiving member (a substrate) (109) between said printhead structure (106) and said back electrode (105) in the direction indicated by arrow A at a linear speed LSS,

(v) a scraper blade (114), placed downstream of the development zone (113) for removing the non-used charged toner particles from said CTC, and a collecting means (115) for collecting the removed toner particles.

(vi) means (116) for recycling said removed toner particles to the container for non-magnetic mono-component developer and

(vii) means for fixing (110) said toner onto said image receiving member.

[0035] In figure 3, a DEP device according to the second implementation of a device according to this invention is shown wherein the charged toner particles on the surface of the CTC are brought there by a magnetic brush from a two-component developer. Such device comprises : (i) a means for bringing non magnetic charged toner particles to the surface (103a) of a charged toner conveyer, comprising a container (101) for two component developer (102), with non-magnetic toner particles (102a) and magnetic carrier particles (102b), a magnetic brush (104), with a magnetic core (104a) and a non-magnetic sleeve (104b). Said sleeve is equipped with a means (not shown in the figure) for rotating said sleeve, in the direction of arrow C so that the surface of the sleeve has a linear speed LSM. Said sleeve is coupled to a DC-voltage source V5 and an AC-voltage source AC1 for jumping charged toner particles upon the surface (103a) of said charged toner conveyer (103) from said two component developer. The charged toner conveyer (103) is equipped with a means (not shown in the figure) for rotating said it, in the direction of arrow B, which is opposite to the direction of rotation of the sleeve of the magnetic brush, so that the toner bearing surface (103a) of it has a linear speed LSC. The CTC is rotated so that the charged toner particles on its surface are brought in the development zone (113), the magnetic brush (104) is located upstream of the development zone.

(ii) a back electrode (105) coupled to a DC-voltage source V4, for maintaining said back electrode at a voltage different from the voltage (V1) applied to the surface of the CTC, for forming an electrical propulsion field wherein a flow (111) of charged toner particles is created from the surface of the CTC towards the back electrode.

(iii) a printhead structure (106), made from a plastic insulating film, coated on both sides with a metallic film. The

printhead structure (106) comprises one continuous electrode surface, hereinafter called "shield electrode" (106b) coupled to a voltage source V2 facing in the shown embodiment the CTC and a complex addressable electrode structure, hereinafter called "control electrode" (106a) around printing apertures (107) and coupled to a variable voltage V3. Said printhead structure is placed in said flow of toner particles so that by applying a varying voltage V3 to the control electrode the flow of toner particles towards the back electrode can be image-wise modulated in the development zone (113). Said printing apertures are arranged in an array structure for which the total number of rows can be chosen according to the field of application.

(iv) conveyer means (108) to convey an image receiving member (a substrate) (109) between said printhead structure (106) and said back electrode (105) in the direction indicated by arrow A at a linear speed LSS,

(v) a scraper blade (114), placed downstream of the development zone (113) for removing the non-used charged toner particles from said CTC, and a collecting means (115) for collecting the removed toner particles.

(vi) means (116, 121) for recycling said removed toner particles to the magnetic brush, said means (116) being coupled to mixing means (117) that is coupled to a storage means (118) for fresh carrier particles, a storage means (119) for fresh toner particles and an inlet (120) for used developer from said container (101). In this mixing means the removed non-used toner particles are mixed with fresh toner particles and with recycled and fresh carrier particles as to recycle two component developer in the magnetic brush and

(vii) means for fixing (110) said toner onto said image receiving member.

[0036] The mixing means (117) can be provided with a system for measuring the ratio toner particles/carrier particles present in said mixing means and the measuring system can be coupled to means for selectively opening and closing the inlets of the container for fresh toner(119), the container of fresh carrier (118) and the inlet (120) for bringing (used) developer to the mixing means.

[0037] It is clear that the mixing means (117) shown in figure 3 to be coupled to containers for fresh toner and fresh carrier (118,119) and to means (120) for bringing developer to the mixing means, can be omitted totally from the device so that the recovered non-used toner particles are directly as such recycled to the container (101). A device wherein the mixing means is only coupled to a container for fresh toner, or only to a container for fresh carrier or only to means (120) for bringing developer to the mixing means is also within the scope of the present invention. Also devices wherein the mixing means are coupled to only two of a container for fresh toner, a container for fresh carrier or means (120) for bringing developer to the mixing means is also within the scope of the present invention.

[0038] The means (104, 1041) for bringing charged non-magnetic toner particles to the surface (103a) of the CTC can be equipped for applying a mono layer of said toner particles on the surface of the CTC or for applying multiple layers of said toner particles on top of each other. In the latter case it can be beneficial to install one or more doctor blades near the CTC between said means (104, 1041) for bringing charged non-magnetic toner particles to the surface (103a) of the CTC and said development zone, (i.e. downstream of the means for bringing toner particles to the CTC and upstream of the development zone), for regulating the thickness of said multiple layers of toner particles.

[0039] The location and/or form of the shield electrode (106b) and the control electrode (106a) can, in other embodiments of a device for a DEP method using toner particles according to the present invention, be different from the location shown in fig. 2 or fig 3..

[0040] Although in fig. 2 and 3 an embodiment of a device for a DEP method using two electrodes (106a and 106b) on printhead 106 is shown, it is possible to implement a DEP method, using toner particles according to the present invention using devices with different constructions of the printhead (106). It is, e.g. possible to implement a DEP method with a device having a printhead comprising only one electrode structure as well as with a device having a printhead comprising more than two electrode structures. The apertures in these printhead structures can have a constant diameter, or can have a broader entrance or exit diameter.

[0041] The back electrode (105) of this DEP device can also be made to co-operate with the printhead structure, said back electrode being constructed from different styli or wires that are galvanically isolated and connected to a voltage source as disclosed in e.g. US-A-4,568,955 and US-A-4,733,256. The back electrode, co-operating with the printhead structure, can also comprise one or more flexible PCB's (Printed Circuit Board).

[0042] Between said printhead structure (106) and the charged toner conveyer (103) as well as between the control electrode around the apertures (107) and the back electrode (105) behind the toner receiving member (109) as well as on the single electrode surface or between the plural electrode surfaces of said printhead structure (106) different electrical fields are applied. In the specific embodiment of a device, useful for a DEP method, using a printing device with a geometry according to the present invention, shown in fig 2. voltage V1 is applied to the sleeve of the charged toner conveyer 103, voltage V2 to the shield electrode 106b, voltages V3₀ up to V3_n for the control electrode (106a). The value of V3 is selected, according to the modulation of the image forming signals, between the values V3₀ and V3_n, on a time basis or grey-level basis. Voltage V4 is applied to the back electrode behind the toner receiving member. In other embodiments of the present invention multiple voltages V2₀ to V2_n and/or V4₀ to V4_n can be used. Voltage V5 is applied to the surface of the sleeve of the magnetic brush.

[0043] In a DEP device according to the present invention an additional AC-source can beneficially be connected to the sleeve of said magnetic brush.

[0044] The magnetic brush 104 preferentially used in a DEP device according to the present invention is of the type with stationary core and rotating sleeve.

5 [0045] In a DEP device, according to a preferred embodiment of the present invention, any type of known carrier particles and toner particles can successfully be used. It is however preferred to use "soft" magnetic carrier particles. "Soft" magnetic carrier particles useful in a DEP device according to a preferred embodiment of the present invention are soft ferrite carrier particles. Such soft ferrite particles exhibit only a small amount of remanent behaviour, characterised in coercivity values ranging from about 4 kA/m up to 20 kA/m (50 up to 250 Oe). Further very useful soft magnetic carrier
10 particles, for use in a DEP device according to a preferred embodiment of the present invention, are composite carrier particles, comprising a resin binder and a mixture of two magnetites having a different particle size as described in EP-B 289 663. The particle size of both magnetites will vary between 0.05 and 3 µm. The carrier particles have preferably an average volume diameter (d_{v50}) between 10 and 300 µm, preferably between 20 and 100 µm. More detailed descriptions of carrier particles, as mentioned above, can be found in EP-A-675 417.

15 [0046] It is preferred to use in a DEP device according to the present invention, toner particles with an absolute average charge over mass ratio ($|q/m|$) corresponding to $5 \mu\text{C/g} \leq |q/m| \leq 15 \mu\text{C/g}$, preferably to $8 \mu\text{C/g} \leq |q/m| \leq 11 \mu\text{C/g}$. The charge to mass ratio of the toner particles is measured by mixing the toner particles with carrier particles, and after 15 min of charging the q/m-ratio is measured with a device such as the Toshiba TB-200 blow-off tester. In this disclosure the charge to mass ratio is taken as the absolute value, as a DEP device according to
20 this invention can function either with negatively charged toner particles or with positively charged toner particles depending on the polarity of the potential difference between V1 and V4. Preferably the toner particles used in a device according to the present invention have an average volume diameter (d_{v50}) between 1 and 20 µm, more preferably between 3 and 15 µm. More detailed descriptions of toner particles, as mentioned above, can be found in EP A 675 417 that is incorporated herein by reference.

25 [0047] A DEP device making use of the above mentioned marking toner particles can be addressed in a way that enables it to give black and white. It can thus be operated in a "binary way", useful for black and white text and graphics and useful for classical bi-level half-toning to render continuous tone images.

[0048] A DEP device according to the present invention is especially suited for rendering an image with a plurality of grey levels. Grey level printing can be controlled by either an amplitude modulation of the voltage V3 applied on the control electrode 106a or by a time modulation of V3. By changing the duty cycle of the time modulation at a specific frequency, it is possible to print accurately fine differences in grey levels. It is also possible to control the grey level printing by a combination of an amplitude modulation and a time modulation of the voltage V3, applied on the control electrode.

[0049] The combination of a high spatial resolution and of the multiple grey level capabilities typical for DEP, opens the way for multilevel half-toning techniques, such as e.g. described in EP-A-634 862 with title "Screening method for a rendering device having restricted density resolution". This enables the DEP device, according to the present invention,
35 to render high quality images.

EXAMPLES

40 [0050] Throughout the printing examples, the same developer, comprising toner and carrier particles was used.

The carrier particles

[0051] A macroscopic "soft" ferrite carrier consisting of a MgZn-ferrite with average particle size 50 µm, a magnetisation at saturation of 36 Tm³/kg (29 emu/g) was provided with a 1 µm thick acrylic coating. The material showed virtually
45 no remanence.

The toner particles

50 [0052] The toner used for the experiment had the following composition : 97 parts of a co-polyester resin of fumaric acid and bispropoxylated bisphenol A, having an acid value of 18 and volume resistivity of 5.1×10^{16} ohm.cm was melt-blended for 30 minutes at 110° C in a laboratory kneader with 3 parts of Cu-phthalocyanine pigment (Colour Index PB 15:3). A resistivity decreasing substance - having the following formula : $(\text{CH}_3)_3\text{N}^+\text{C}_{16}\text{H}_{33} \text{Br}^-$ was added in a quantity of 0.5 % with respect to the binder, as described in WO-A-94/027192.

55 [0053] After cooling, the solidified mass was pulverised and milled using an ALPINE Fließbettgegenstrahlmühle type 100AFG (trade name) and further classified using an ALPINE multiplex zig-zag classifier type 100MZR (trade name). The average particle size was measured by Coulter Counter model Multisizer (trade name), was found to be 6.3 µm by number and 8.2 µm by volume. In order to improve the flowability of the toner mass, the toner particles were mixed with

0.5 % of hydrophobic colloidal silica particles (BET-value 130 m²/g).

The developer

5 **[0054]** An electrostatographic developer was prepared by mixing said mixture of toner particles and colloidal silica in a 5 or 10 % ratio (wt/wt) with carrier particles. The triboelectric charging of the toner-carrier mixture was performed by mixing said mixture in a standard tumbling set-up for 10 min. The developer mixture was run in the magnetic brush for 5 minutes, after which the toner was sampled and the tribo-electric properties were measured using the Toshiba TB-200 blow-off device, resulting in a q/m-ratio of -14 µC/g.

10

The printhead structure (106)

[0055] A printhead structure (106) was made from a polyimide film of 50 µm thickness, double sided coated with a 5 µm thick copper film. The printhead structure (106) had two rows of printing apertures. On the back side of the printhead structure, facing the image receiving member, a rectangular shaped control electrode (106a) was arranged around each aperture. Each of said control electrodes was connected over 2 MΩ resistors to a HV 507 (trade name) high voltage switching IC, commercially available through Supertex, USA, that was powered from a high voltage power amplifier. The printing apertures were rectangular shaped with dimensions of 360 by 120 µm. The dimension of the central part of the rectangular shaped copper control electrodes was 500 by 260 µm. The apertures were spaced so to obtain a resolution of 33 dots/cm (85 dpi). On the front side of the printhead structure, facing the charged toner conveyer roller, a common shield electrode (106b) was arranged around the aperture zone leaving a free polyimide zone of 1620 µm. Said printhead structure was fabricated in the following way. First of all the control and shield electrode pattern was etched by conventional copper etching techniques. The apertures were made by a step and repeat focused excimer laser making use of the control electrode patterns as focusing aid. After excimer burning the printhead structure was cleaned by a short isotropic plasma etching cleaning. Finally a thin coating of PLASTIK70, commercially available from Kontakt Chemie, was applied over the control electrode side of said printhead structure.

The charged toner conveyer (CTC)

30 **[0056]** The CTC was a cylinder with a sleeve made of aluminium, coated with TEFLON (trade name of Du Pont, Wilmington, USA) with a surface roughness of 2.2 µm (Ra-value) and a diameter of 30 mm. The charged toner conveyer (103) was connected to a DC power supply of 0V.

Bringing charged toner particles to the CTC

35

[0057] Charged toner particles were propelled to this conveyer from a stationary core (104a)/rotating sleeve (104b) type magnetic brush (104) comprising two mixing rods and one metering roller. One rod was used to transport the developer through the unit, the other one to mix toner with developer.

40 **[0058]** The magnetic brush 104 was constituted of the so called magnetic roller, which in this case contained inside the roller assembly a stationary magnetic core (104a), having three magnetic poles with an open position (no magnetic poles present) to enable used developer to fall off from the magnetic roller (open position was one quarter of the perimeter and located at the position opposite to said CTC (103).

The sleeve (104b) of said magnetic brush had a diameter of 20 mm and was made of stainless steel roughened with a fine grain to assist in transport (Ra=3 µm) and showed an external magnetic field strength in the zone between said magnetic brush and said CTC of 0.045 T, measured at the outer surface of the sleeve of the magnetic brush. The magnetic brush was connected to an AC power supply (AC1) with a square wave oscillating field between 500-3750 V peak to peak at a frequency of 3.0 kHz with -50 to -200 V DC-offset. The voltages of the AC-field and the DC offset (V5) were varied for the various printing examples (see table 1)

50 **[0059]** A scraper blade was used to force developer to leave the magnetic roller. On the other side a doctoring blade was used to meter a small amount of developer onto the surface of said magnetic brush. The sleeve was rotating at a linear surface speed (LSM) four times higher than the linear surface speed (LSC) of said CTC roller, and in a direction opposite to the rotation direction of said CTC-roller.

The reference surface of said CTC was placed at a distance between 550-800 µm from the reference surface of said magnetic brush. This distance was varied for the various printing examples (see table 1)

55

The printing engine

[0060] The printhead structure, mounted in a PVC-frame, was bent with frictional contact over the surface of the roller

of the charged toner conveyer roller. A 50 μm (this is distance d) thick polyurethane coating was used as self-regulating spacer means (110).

[0061] A back electrode was present behind the paper whereon the printing proceeded, the distance between the back electrode (105) and the back side of the printhead structure (d_B) was set to 1000 μm and the paper travelled a linear speed (LSM) of 200 cm/min. The back electrode was connected to a high voltage power supply, applying a voltage V_4 of + 1000 V to the back electrode.

[0062] The shield electrode 106b was grounded $V_2 = 0$ V. To the individual control electrodes an (image-wise) voltage V_3 between 0 V and +280 V was applied.

10 Measurement of printing quality

[0063] A printout made on paper with a DEP device and developer described above, was judged for homogeneity of the image density after a long printing run.

The results are given in table 1. In this table the data on cloudiness are summarised according to the following ranking :

- 15
- 1: unacceptable : severe cloudiness.
 - 2: poor : cloudiness still clearly visible.
 - 3: acceptable : very little cloudiness visible.
 - 4: good : cloudiness barely visible.
 - 20 5: very good : an homogeneous image density is obtained, with almost no cloudiness visible.

PRINTING EXAMPLES 1-9 (PE1-9)

[0064] In these experiments the charged toner conveyer roller was fed from a single magnetic brush, wherein the distance between said magnetic brush and said charged toner conveyer roller was modified, the DC and AC-potential applied towards the sleeve of said magnetic brush was modified, and in which the toner concentration of the developer used was modified. The CTC was not cleaned downstream of the development zone. The parameters of the printing engine are summarised in table 1 and the printing results in table 2.

30 PRINTING EXAMPLE 10 (PE10)

[0065] In this printing example a scraper blade was placed downstream of the development zone to remove all unused toner from the charged toner conveyer roller. Said toner was removed by means of air suction. The amount of consumed toner was calculated and the developer in said magnetic brush was "compensated" for this removed amount of toner by fresh toner. No recycling of the removed non-used toner particles took place. The parameters of the printing engine are summarised in table 1 and the printing results in table 2.

PRINTING EXAMPLE 11 (PE11)

[0066] In this printing example a scraper blade was used to remove all unused toner from the charged toner conveyer roller. Said toner was removed by pumping used developer through the tube in which said toner was pushed by said scraper blade. The amount of consumed toner was calculated and the developer in said magnetic brush was "compensated" for this removed amount of toner by mixing the removed non-used toner particles with part of the developer and then added to the container of said magnetic brush holding said developer material. In this example, the removed non-used toner particles were recycled. The parameters of the printing engine are summarised in table 1 and the printing results in table 2.

PRINTING EXAMPLE 12 (PE12)

[0067] Experiment 11 was repeated except for the cleaning of the CTC downstream of the development zone : a rotating roller with foamed polymers was used in stead of said scraper blade of experiment 11.

[0068] The parameters of the printing engine are summarised in table 1 and the printing results in table 2.

PRINTING EXAMPLE 13 (PE13)

[0069] Experiment 11 was repeated except for the cleaning of the CTC downstream of the development zone : a pulling magnetic brush was used in stead of said scraper blade of experiment 11. The pulling magnetic brush was connected to a "suction" field. The non-used toner particles were not recycled. The parameters of the printing engine are

summarised in table 1 and the printing results in table 2.

Table 1

5
10
15
20
25

Parameters of the printing engine.								
#	TC in %	X in μm	V1 in V	V4 in V	V5 in V	AC1 in V	Clean	Recycle
PE1	5	650	0	1000	- 200	0	no	no
PE2	5	650	0	1000	- 50	0	no	no
PE3	5	650	0	1000	- 100	500	no	no
PE4	5	650	0	1000	- 100	2000	no	no
PE5	5	650	0	1000	- 100	3750	no	no
PE6	5	800	0	1000	- 100	500	no	no
PE7	5	800	0	1000	- 100	3000	no	no
PE8	10	800	0	1000	- 100	500	no	no
PE9	10	800	0	1000	- 100	3000	no	no
PE10	5	650	0	1000	- 100	1750	sb	no
PE11	5	650	0	1000	- 100	1750	sb	yes
PE12	5	650	0	1000	- 100	1750	fr	yes
PE13	5	650	0	1000	- 100	1750	pb	no

Abbreviations:

30 **[0070]**

- TC = toner concentration as % (wt/wt) toner versus carrier;
- X = distance in μm between charged toner conveyer (CTC) and magnetic brush
- V1 : DC voltage on the CTC
- V4 : DC voltage on the back electrode
- V5 : DC voltage on the sleeve of the magnetic brush
- AC1 : AC voltage on the sleeve of the magnetic brush
- Clean : cleaning of the CTC downstream of the development zone

- no = no cleaning
- sb = cleaning with scraper blade,
- fr = cleaning with a foamed polymer roller
- pb = cleaning with a pulling magnetic brush

45 Recycle : recycling of the non-used toner particles, yes or no.

Table 2

50
55

Results of the printing									
#	m1 in g/m^2	m2 in g/m^2	m10 in g/m^2	m60 in g/m^2	q1 in $\mu\text{C/g}$	q2 in $\mu\text{C/g}$	q10 in $\mu\text{C/g}$	q60 in $\mu\text{C/g}$	QC after 60 min printing
PE1	9.1	17.3	21.6	na	12.5	12.5	15.1	na	2
PE2	3.4	5.9	8.4	na	11.5	12.9	15.2	na	2
PE3	7.2	12.5	14.1	na	12.6	12.8	16.1	na	2

Table 2 (continued)

Results of the printing									
#	m1 in g/m ²	m2 in g/m ²	m10 in g/m ²	m60 in g/m ²	q1 in μC/g	q2 in μC/g	q10 in μC/g	q60 in μC/g	QC after 60 min printing
PE4	10.7	11.8	11.5	na	18.9	21.8	24.7	na	2
PE5	2.3	4.5	8.0	na	14.1	16.1	20.3	na	1
PE6	4.5	8.6	13.1	11.1	11.2	11.3	14.1	21.8	3
PE7	5.7	11.2	14.0	na	11.4	11.2	14.5	na	3
PE8	8.0	13.3	15.9	13.0	8.2	8.2	12.2	18.4	3
PE9	2.0	4.3	8.7	8.0	7.1	9.1	10.6	10.5	3
PE10	9.0	8.9	9.1	9.0	13.5	13.5	13.6	13.6	5
PE11	8.9	9.2	9.1	9.0	13.6	13.5	13.5	13.6	5
PE12	8.9	8.9	9.1	9.1	13.5	13.5	13.7	13.6	5
PE13	8.9	8.9	8.1	7.6	13.5	13.5	13.9	16.5	3

Abbreviations

[0071]

- m1 = toner mass on the CTC after 1 revolution
- m2 = toner mass on the CTC after 2 revolutions
- m10 = toner mass on the CTC after 10 minutes printing
- m60 = toner mass on the CTC after 60 minutes printing
- q1 = charge-to-mass ratio of toner on CTC measured after 1 revolution
- q2 = charge-to-mass ratio of toner on CTC after 2 revolutions
- q10 = charge-to-mass ratio of toner on CTC after 10 minutes printing
- q60 = charge-to-mass ratio of toner on CTC after 60 minutes printing
- na : not available
- QC = visual perception of image quality which is merely determined by the unevenness and ghost images

[0072] It is clear from the examples above that only in the printing experiments wherein the CTC is cleaned with a kind of mechanical means (scraper blade, foamed roller) a stable load of toner particles with a stable charge is maintained on the CTC even after 30 minutes of printing (PE10 to PE12). It is clear that the non-used toner particles can be recycled without deteriorating the printing quality (compare PE10 to PE 11 and PE 12).

[0073] Although a configuration wherein the cleaning proceeds with a pulling magnetic brush (PE13) is acceptable for medium size run lengths it is clear from table 2 that after 30 minutes of printing the stability of the system both in terms of load of toner particles and in terms of charge of the toner particles is deteriorated.

[0074] It must be clear for those skilled in the art that many other implementations of cleaning and recovery systems can be provided without departing from the spirit of the present invention.

Claims

1. A method for Direct Electrostatic Printing (DEP) is provided comprising the steps of :

- bringing charged toner particles from a means for delivering non magnetic toner particles to a toner bearing surface of a conveyer for charged toner,
- applying an electrical potential difference between said toner bearing surface and an image receiving member, for creating a flow of charged toner particles from said surface bearing charged toner particles to an image receiving member,
- placing a printhead structure having printing apertures and control electrodes in said flow, forming a development zone under said printing apertures for image wise depositing toner particles, from said flow of charged

toner particles, on said image receiving member

- moving said conveyer for charged toner particles to pass the toner bearing surface repeatedly through said development zone, in a direction so as to have said magnetic brush upstream of the development zone and
- removing and collecting, downstream from said development zone, non-used toner particles from said toner bearing surface.

- 5
2. A method according to claim 1, wherein said means for delivering toner particles comprises a dispenser for non-magnetic mono-component developer.
- 10
3. A method according to claim 1 or 2, wherein said method further comprises the step of recycling said non-used toner particles in said-means for delivering toner particles.
- 15
4. A method according to claim 1, wherein said means for delivering toner particles comprises a magnetic brush assembly (104) carrying non-magnetic toner particles (102a) and magnetic carrier particles (102b).
5. A method according to claim 4, wherein said method further comprises the step of recycling said non-used toner particles in said means for delivering toner particles.
- 20
6. A method according to claim 5, wherein said method further comprises the step of mixing said non-used toner particles with fresh toner particles.
7. A device for direct electrostatic printing comprising :
- a means (104, 1041) with a container (101, 1011) for bringing charged non-magnetic toner particles to a toner bearing surface (103a) of a conveyer for charged toner (103),
 - one or more voltage sources (V1, V4) for applying an electrical potential difference between said toner bearing surface and an image receiving member (109), for creating a flow (111) of charged toner particles from said surface bearing charged toner particles to said image receiving member,
 - a printhead structure (106) having printing apertures (107) and control electrodes (106a) placed in said flow, forming a development zone (113) under said printing apertures for image wise depositing toner particles, from said flow of charged toner particles, on said image receiving member
 - a means for moving said conveyer for charged toner particles, in a direction of arrow B, to pass said toner bearing surface repeatedly through said development zone so as to have said means for bringing charged toner particles on said surface upstream of the development zone and
 - a means for removing (114) and collecting (115), downstream from said development zone, non-used toner particles from said toner bearing surface.
- 25
8. A device according to claim 7, wherein said means for bringing toner particles to the surface (103a) contains a dispensing roller (1041) for non-magnetic mono component developer (1021).
- 40
9. A device according to claim 7, wherein said means for bringing toner particles to the surface (103a) contains a magnetic brush assembly (104) containing magnetic carrier particles (102b) and non-magnetic toner particles (102a).
- 45
10. A device according to any of claims 7 to 9, further comprising means (116) for recycling said non-used toner particles in said for bringing charged non-magnetic toner particles to said toner bearing surface.
11. A device according to claim 9, further comprising mixing means (117) for mixing the non-used toner particles with fresh toner particles
- 50
12. A device according to claim 9, wherein said collecting means contains mixing means (117) for mixing the non-used toner particles with fresh toner particles.
13. A method according to any of claim 7 to 12, wherein said cleaning means (114) is a scraping blade.
- 55
14. A method according to any of claim 7 to 12, wherein said cleaning means (114) is a foamed polymer roller.

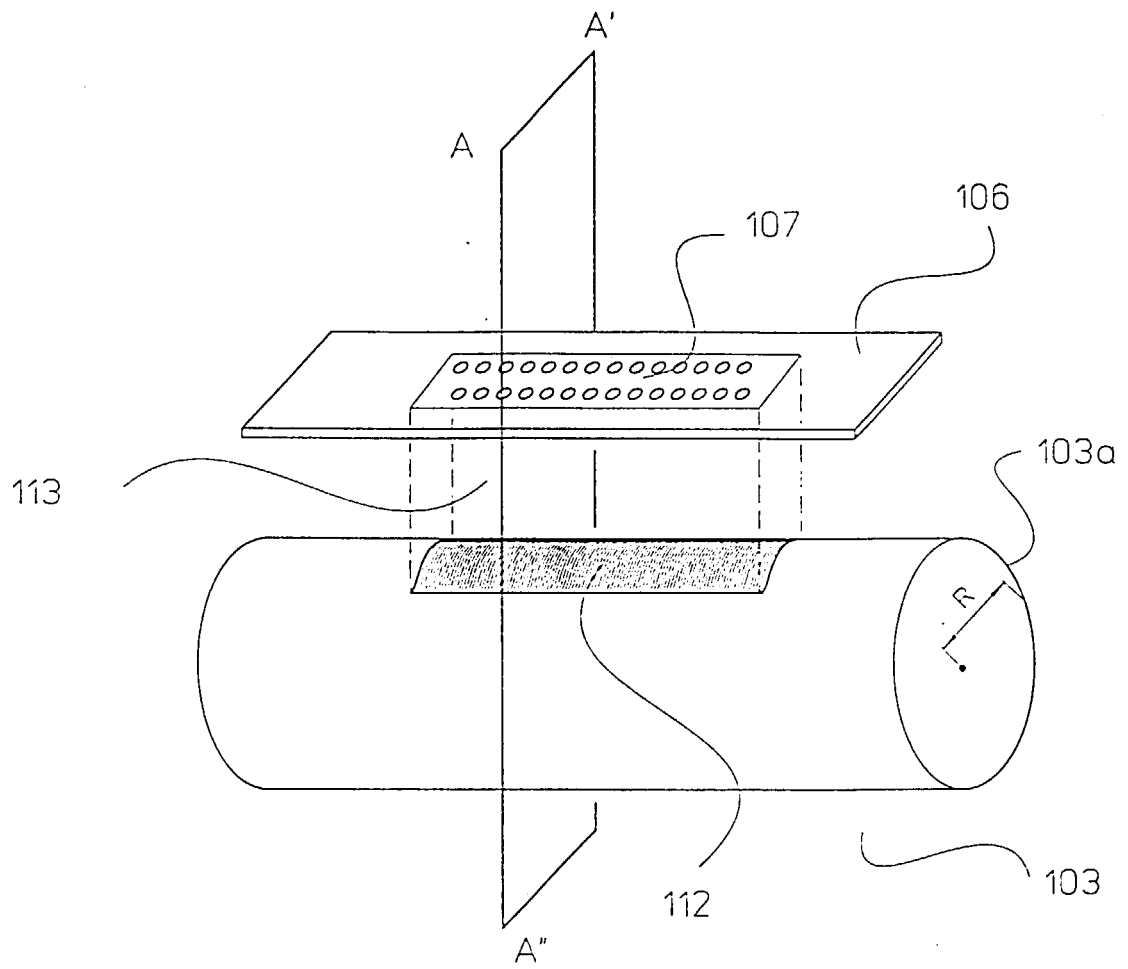

Fig. 1

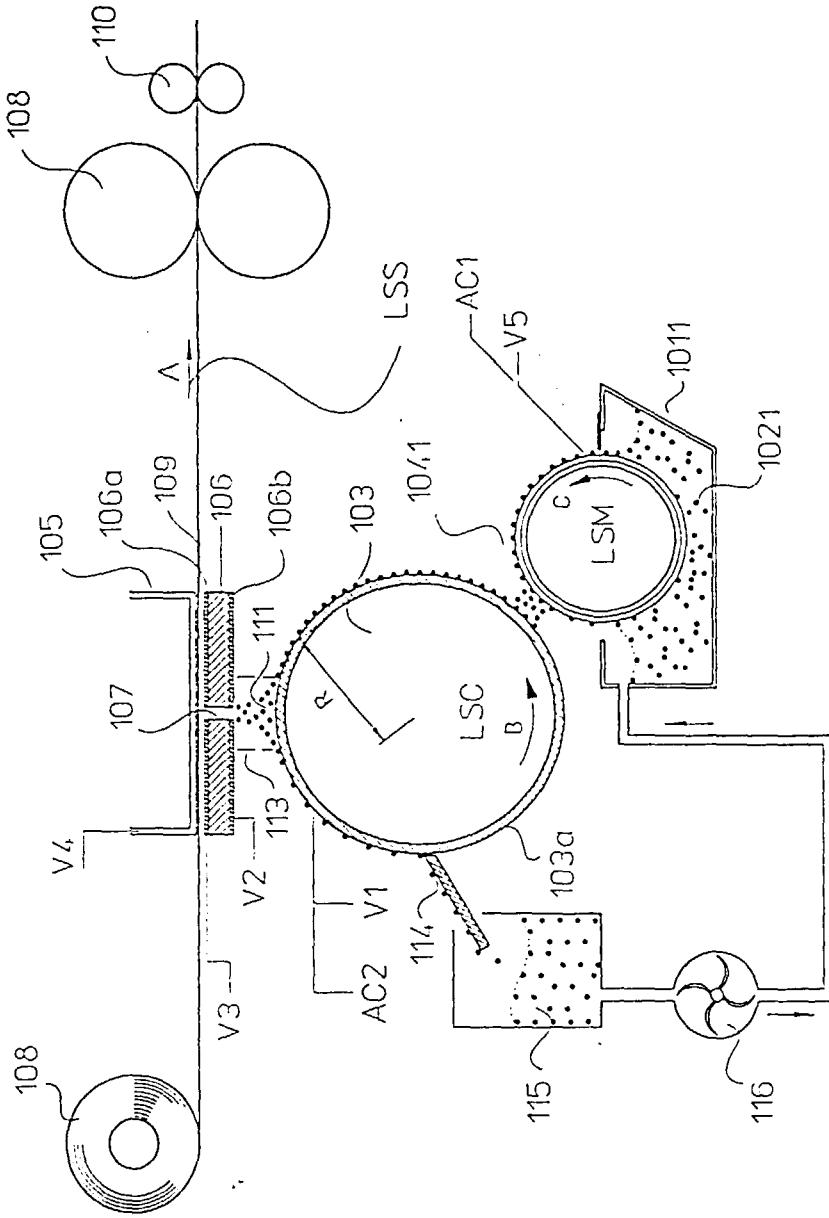

Fig. 2

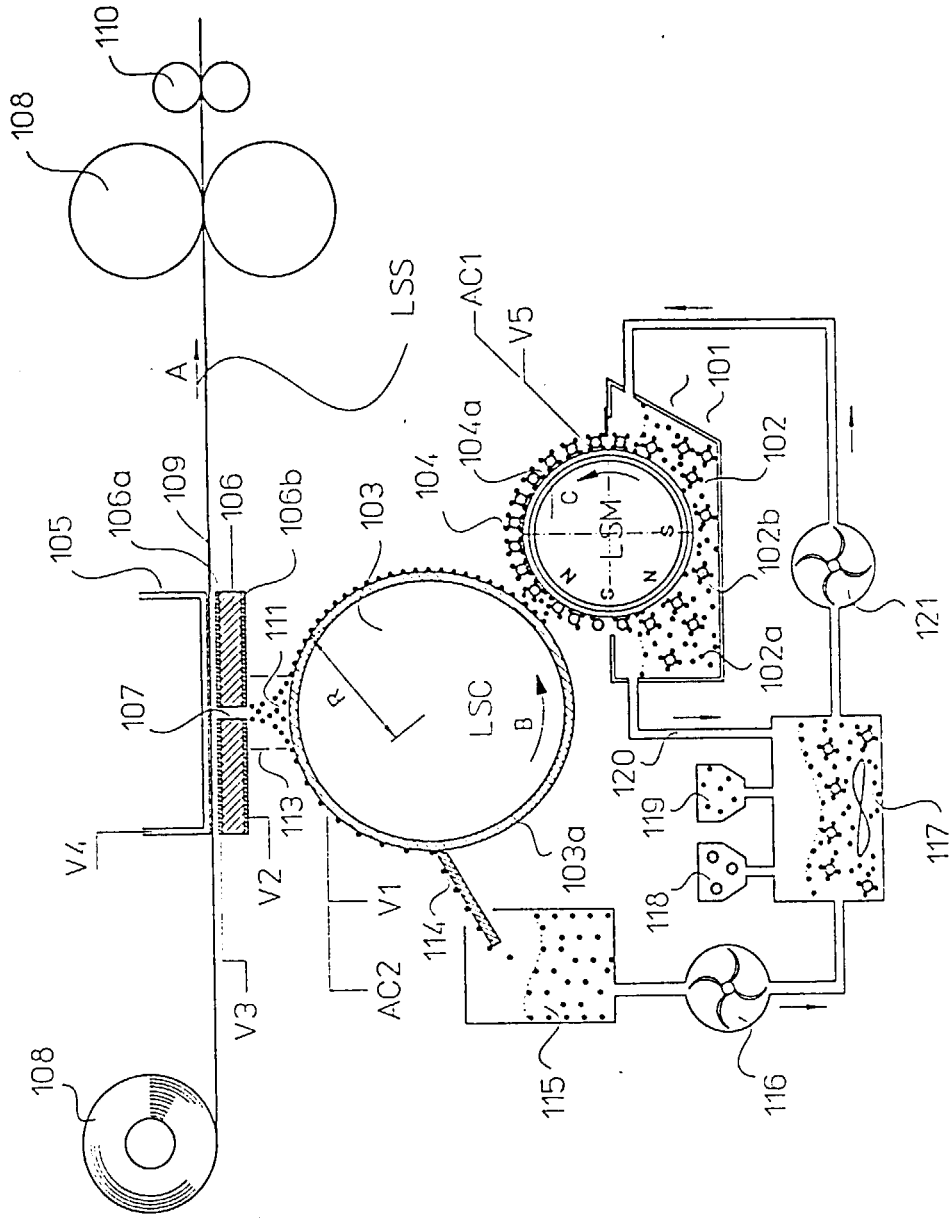

Fig. 3



European Patent Office

EUROPEAN SEARCH REPORT

Application Number
EP 98 20 2607

DOCUMENTS CONSIDERED TO BE RELEVANT			
Category	Citation of document with indication, where appropriate, of relevant passages	Relevant to claim	CLASSIFICATION OF THE APPLICATION (Int.Cl.6)
D,X	DE 197 45 561 A (ARRAY PRINTERS AB) 23 April 1998 * column 3, line 17 - column 5, line 18; figure 1 *	1-3,7, 10,13	G03G15/34 G03G15/08
X	PATENT ABSTRACTS OF JAPAN vol. 095, no. 008, 29 September 1995 -& JP 07 121030 A (BROTHER IND LTD), 12 May 1995 * abstract *	1,3,7,13	
A	US 5 479 195 A (TAKAGI OSAMU) 26 December 1995 * column 3, line 60 - column 4, line 22; figure 1 *	1,3,5,7, 10	
A	EP 0 709 748 A (SHARP KK) 1 May 1996 * column 7, line 56 - column 8, line 2 * * column 12, line 43 - line 54; figures 2,5 *	1-3,7,8, 14	
			TECHNICAL FIELDS SEARCHED (Int.Cl.6)
D,A	US 5 040 004 A (SCHMIDLIN FRED W ET AL) 13 August 1991 * column 3, line 6 - line 57; figure 1 *	1,3,4,7, 9,10,13	G03G
A	US 5 247 333 A (YAMAMOTO MIKIO ET AL) 21 September 1993 * column 8, line 10 - column 10, line 18; figure 1A *	1-3,7,8, 10-13	
A	PATENT ABSTRACTS OF JAPAN vol. 009, no. 113 (P-356), 17 May 1985 -& JP 59 232370 A (TOSHIBA KK), 27 December 1984 * abstract *	1,3,5-7, 10-12	
The present search report has been drawn up for all claims			
Place of search THE HAGUE		Date of completion of the search 8 December 1998	Examiner Cigoj, P
CATEGORY OF CITED DOCUMENTS X : particularly relevant if taken alone Y : particularly relevant if combined with another document of the same category A : technological background O : non-written disclosure P : intermediate document		T : theory or principle underlying the invention E : earlier patent document, but published on, or after the filing date D : document cited in the application L : document cited for other reasons & : member of the same patent family, corresponding document	

EPO FORM 1503 03.82 (P04C01)

**ANNEX TO THE EUROPEAN SEARCH REPORT
ON EUROPEAN PATENT APPLICATION NO.**

EP 98 20 2607

This annex lists the patent family members relating to the patent documents cited in the above-mentioned European search report. The members are as contained in the European Patent Office EDP file on
The European Patent Office is in no way liable for these particulars which are merely given for the purpose of information.

08-12-1998

Patent document cited in search report	Publication date	Patent family member(s)	Publication date
DE 19745561 A	23-04-1998	JP 10119339 A	12-05-1998
US 5479195 A	26-12-1995	JP 7128898 A	19-05-1995
EP 0709748 A	01-05-1996	JP 8129300 A	21-05-1996
		US 5726695 A	10-03-1998
US 5040004 A	13-08-1991	JP 3196061 A	27-08-1991
US 5247333 A	21-09-1993	JP 6051623 A	25-02-1994