

No. 680,455.

Patented Aug. 13, 1901.

J. GOGEL.
TIRE HEATER.

(Application filed May 21, 1900.)

(No Model.)

Fig. 1.

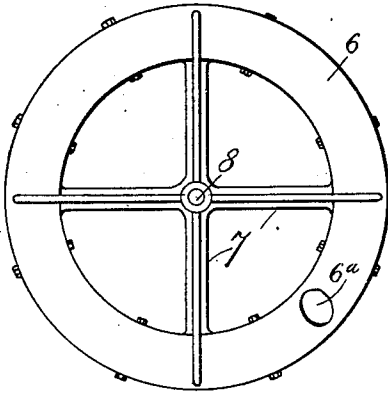

Fig. 2.

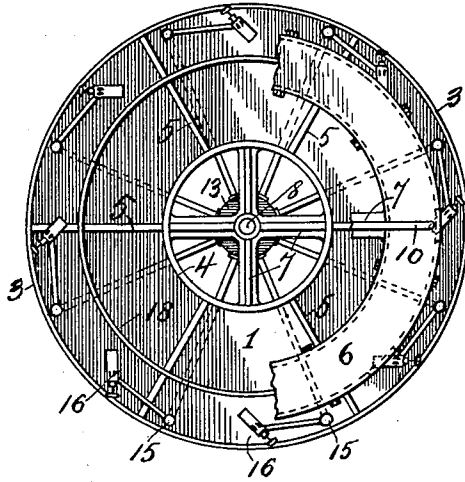

Fig. 3.

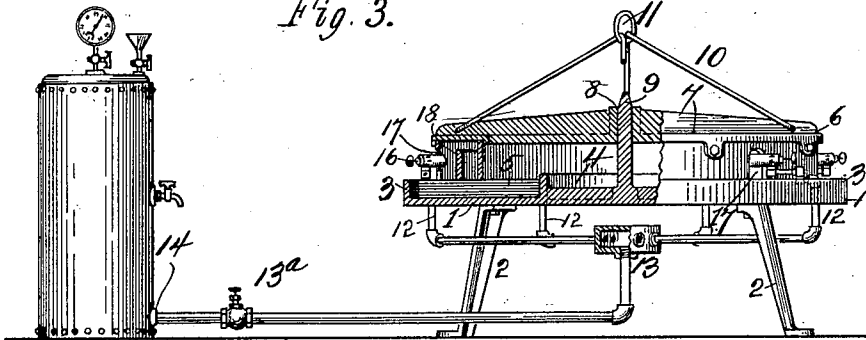
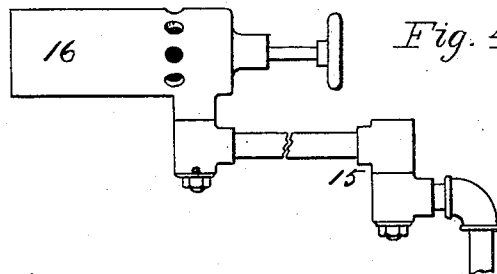

Fig. 4.



WITNESSES:

David C. Walter
L. Dorn.

INVENTOR.

Jacob Gogel
By his Atty,
Howard Hall.

UNITED STATES PATENT OFFICE.

JACOB GOGEL, OF TOLEDO, OHIO.

TIRE-HEATER.

SPECIFICATION forming part of Letters Patent No. 680,455, dated August 13, 1901.

Application filed May 21, 1900. Serial No. 17,403. (No model.)

To all whom it may concern:

Be it known that I, JACOB GOGEL, a citizen of the United States, residing at Toledo, in the county of Lucas and State of Ohio, have invented certain new and useful Improvements in Tire-Heaters; and I do declare the following to be a full, clear, and exact description of the invention, such as will enable others skilled in the art to which it appertains to make and use the same, reference being had to the accompanying drawings, and to the figures of reference marked thereon, which form a part of this specification.

My invention relates to and its object is to provide a cheap, simple, and efficient device for heating tires by means of a liquid or gaseous fuel. I attain this object by means of the devices and arrangement of parts hereinafter described, and shown and illustrated in the accompanying drawings, in which—

Figure 1 is a top plan view of the cover, hereinafter referred to; Fig. 2, a top plan view of my heater with a portion of the cover broken away to show the arrangement of the parts. Fig. 3 is a side elevation of my device, partly in vertical section; and Fig. 4, an enlarged view of one of the burners hereinafter referred to.

Like numerals of reference indicate like parts throughout the drawings.

In the drawings, 1 is a circular table supported at a suitable height by legs 2. At its outer edge the table is provided with an upturned rim 3. The table has also an upwardly-projecting inner flange 4 about the same height as the flange 3, also a series of upwardly-projecting ribs 5, radiating at regular intervals from the flange 4 to the flange 3. These ribs are also about the same height as the flanges 3 and 4. The compartments between the flanges and the radial ribs are filled with powdered coke, sand, or the like.

6 is a cover consisting of a broad flat ring with downwardly-turned flanges at its inner and outer margins forming in transverse section an inverted U. In the same plane with the flat ring of the cover are cross-arms 7, provided at their intersection with an aperture 8, which fits loosely a spindle 9, projecting upwardly from the center of the table, which spindle serves as a guide for the cover. The cover is provided with converging links

or rods 10, which at their central meeting point have a link or loop 11, by means of which the cover may be hoisted and swung out of the way when desired.

6* is a draft-vent in the top of the cover 6. Disposed at equidistant intervals around the table are upwardly-projecting pipes 12, which are connected, as at 13 and 14, with a common source of liquid or gaseous fuel. In the example of my invention under consideration I have for illustration shown my device provided with a series of burners for gasolene or naphtha connected with a tank, the contents of which may be placed under atmospheric pressure. Each of the pipes 12 at its upper end is provided with a swiveled horizontal pipe 15, carrying a suitable burner 16, which may within certain limits be swung horizontally into any desired position. In the outer downwardly-projecting rim or flange of the cover 6 are formed vertical slots, as at 17, corresponding in number and arrangement with the burners. The arrangement of the burners and the slots in relation to each other is such that each of the burners may be swung into and out of the slotted opening and such that the flame from the burner will be projected into the annular chamber formed by the cover and the table. The swiveled burners are preferably turned at such an angle that their flames are projected substantially in a direction tangential to the walls of the annular chamber and tangentially against the tire, thus producing within the annular chamber a continuous circuit or vortex of flame.

The operation of my device is as follows: The tire 18 which is to be heated is placed upon the radial ribs 5 concentric with the table. The cover is swung above the table and down into position so that the tire is inclosed in the annular chamber formed by the cover and the table. The lighted burners or torches 16 are swung upon their swiveled joints, so that the flame is projected through the openings 17 into the chamber of the cover and tangentially against the tire. The annular chamber now becomes a hot furnace, with the flame and gases confined closely to the tire under treatment, and in a very short time the tire becomes sufficiently heated to answer the desired purpose. The cover may

now be lifted out of the way without disarranging or disturbing the burners, as the openings through the outside wall of the cover extend through the lower margin of the wall.

- 5 The tire is removed, another one is put in its place, the cover is lowered without rearranging the burners, and thus the work rapidly proceeds. It will be seen that tires of various sizes may be heated within the chamber of
 10 the cover shown in the drawings. For smaller tires another cover may be provided; but no matter what the size of the tire within the limit of the table the burners may by reason of the swiveled joints be swung into proper
 15 operative position to heat the tire.

In order that the strength of the fires may be simultaneously and uniformly regulated, I have provided the supply-pipe with a cock or valve 13^a, which will control the flow of the
 20 liquid or gaseous fuel to all the burners.

Having described my invention, what I claim, and desire to secure by Letters Patent, is—

1. In a tire-heater, a bench or table, a tire-
 25 cover having an annular chamber, a series of openings through the wall of the annular

chamber, a burner for each of said openings, and a swiveled support for each of said burners, whereby they may be projected into and
 30 withdrawn from said opening.

2. In a tire-heater, a table, radial ribs or flanges on the top of the table for the support of the tire, a removable tire-cover substantially of inverted-U shape in cross-section, and
 35 having openings through its wall, and a series of burners adapted to project their flame into and through said openings.

3. In a tire-heater, a bench or table, a tire-cover having an annular chamber, a draft-vent in the top, and a series of openings
 40 through the walls of said chamber, and a swiveled burner for each of said openings, whereby the flames may be projected tangentially into the annular chamber, and produce a continuous circuit of flame therein.
 45

In testimony whereof I affix my signature in presence of two witnesses.

JACOB GOGEL.

Witnesses:

WILBER A. OWEN,
 L. BROWN.