

997,119.

Patented July 4, 1911.

2 SHEETS—SHEET 1.

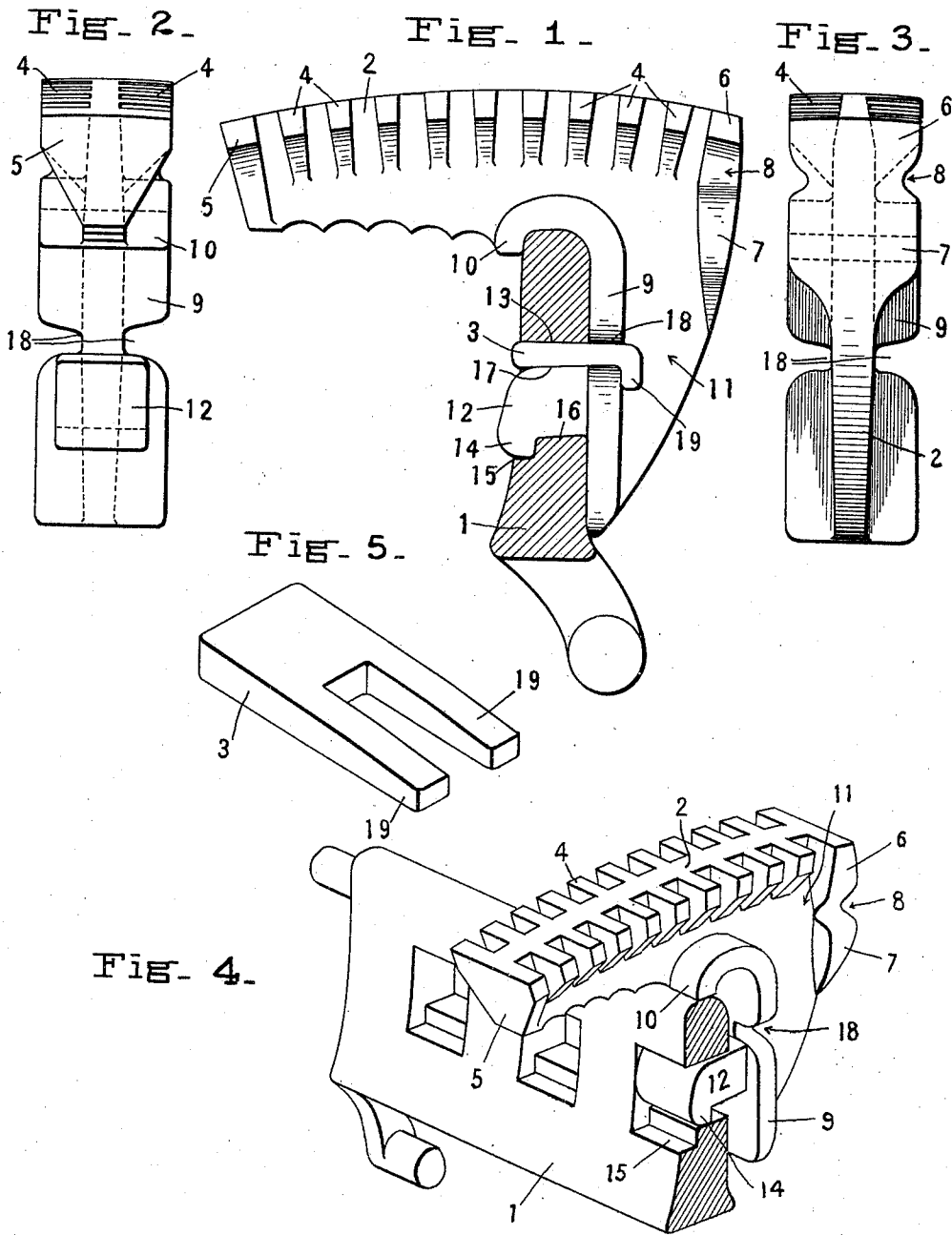

WITNESSES:
J. H. H. H. H.
O. Bradford.

INVENTOR
 Henry B. Eells.
 BY *[Signature]*
 ATTORNEY

997,119.

Patented July 4, 1911.

2 SHEETS—SHEET 2.

FIG- 6 -

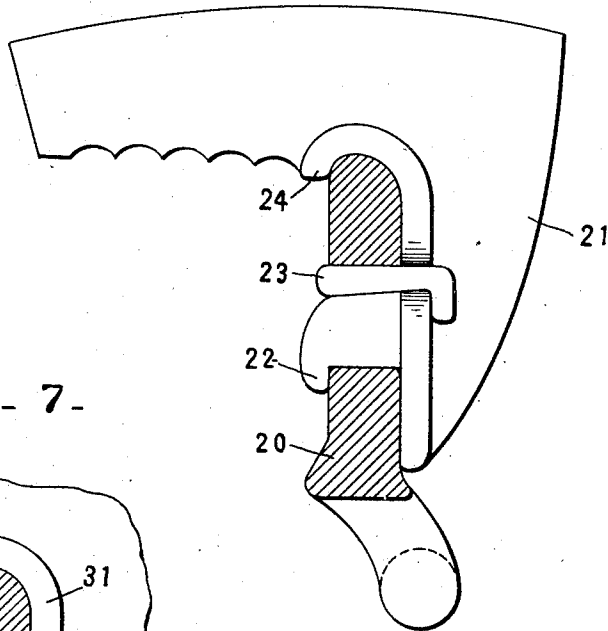

FIG- 7 -

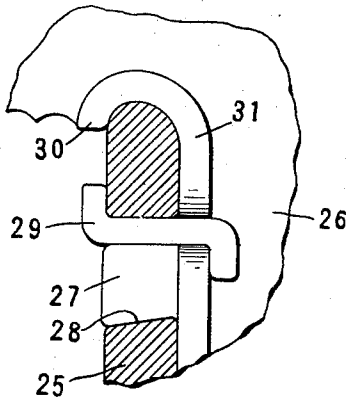

FIG- 8 -

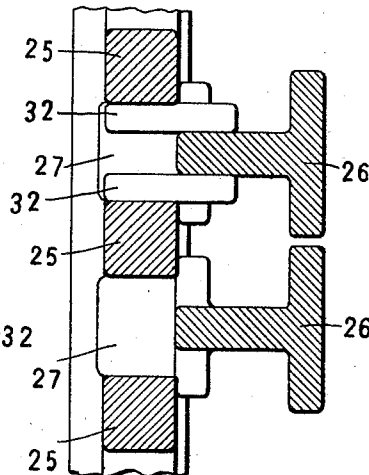

FIG- 10 -

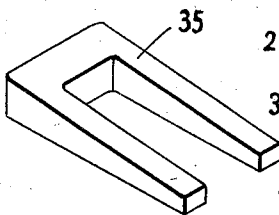
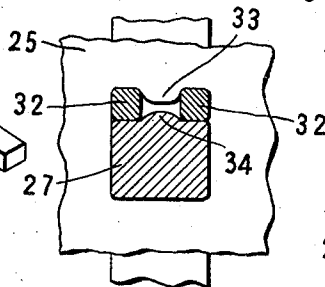

FIG- 9 -



WITNESSES:

J. Lloyd & Co. pty.
C. Bradford

INVENTOR

Henry B. Eells.

BY *[Signature]*
 ATTORNEY

UNITED STATES PATENT OFFICE.

HENRY B. EELLS, OF NEW YORK, N. Y.

GRATE-BAR.

997,119.

Specification of Letters Patent.

Patented July 4, 1911.

Application filed June 8, 1910. Serial No. 565,680.

To all whom it may concern:

Be it known that I, HENRY B. EELLS, a citizen of the United States, residing at New York, in the county of Kings and State of New York, have invented certain new and useful Improvements in Grate-Bars, of which the following is a specification.

My invention relates to improvements in grate bars and more particularly to the type known as shaking, cut-off and dumping grates for furnaces and the like.

A number of forms of bars having detachable fuel supporting members have been proposed and are more or less satisfactory in some cases.

My invention has several objects in view among which are to provide a construction having separate readily attachable and detachable fuel supporting members which is strong and reliable and which is not expensive to make, which will operate satisfactorily and be durable.

The invention in its preferred form and with some modifications is illustrated in the accompanying two sheets of drawings.

The improvements principally relate to the construction and method of attaching the fuel supporting members.

The details of improvement reside in having the tip and heel portions bigger and heavier than the other lateral projections, for breaking their way into the ashes and clinker of the fire; a broad back portion for crushing the ashes and clinker and leaving openings between the heel and back portions to prevent the ashes from being jammed and to permit proper circulation of air; also the provision of a broad vertical throat between the supporting flange and the back portion to permit the ashes to fall through without wedging between the fuel supporting members; also the form and arrangement of downwardly projecting shoulders and lugs carried by the fuel supporting members and the wedges for securing the lugs in openings in the tilting cross bars.

Figure 1, is a cross sectional view of a grate bar showing what may be termed the side of one of the fuel supporting members. Fig. 2, is a front view of a fuel supporting member. Fig. 3, is a rear view of a fuel supporting member. Fig. 4, is a perspective view showing the method of assembling a fuel supporting member on the cross bar. Fig. 5, is a perspective view of one of the

locking wedges. Fig. 6, is a view similar to Fig. 1 showing a slight modification of the means for securing the fuel supporting members to the cross bar. Fig. 7, is a fragmentary view showing a cross section of a slightly different method of securing a fuel supporting member to the cross bar. Fig. 8, is a horizontal section showing two fuel supporting members on the cross bar one of them being secured by a pair of keys. Fig. 9, is a front view of a fragment of the cross bar with the wedges or keys of Fig. 8 in place (in section). Fig. 10, is a perspective view of another key.

The cross bar 1 is of suitable construction and is preferably provided with suitable trunnions so as to enable it to be tilted or rocked back and forth as is customary in tilting and cut-off grates. This cross bar carries a series of separate fuel supporting members such as 2 which are locked in place by wedges or keys such as 3.

Each member 2 preferably has a series of lateral projections such as 4, 4 along both sides at its upper edge with vertical spaces between them for the circulation of air. On the front end of each member the tip 5 projects laterally substantially the same as the projections 4, 4 but the tip is of considerable greater strength and depth. This provides means for starting a comparatively larger hole in the clinker or ashes in the cut-off operation so that as the cut-off motion proceeds a better clearing action is effected. It also strengthens and reinforces the end of the fuel supporting member where the greatest wear and strain occurs. The heel 6 of each fuel supporting member is similarly formed and for a similar purpose so as to more readily break up clinker and ashes on the shaking operation. I also provide a broad back portion 7 which extends laterally of the body 2 just below the heel 6 for crushing the clinker and ashes and also strengthening and reinforcing the member. I prefer also to provide passages such as 8, 8 between the heel 6 and the back 7 which prevents clogging and also permits the air to circulate and prevents overheating of this portion of the grate bar member. Flanges 9, 9 of substantially the same width as the top of the fuel supporting member are provided for affording broad and strong supporting and bearing surfaces in conjunction with the cross bar 1 and spacing the

members apart. The shoulder 10 projecting downwardly opposite the main portion of the flange 9, overhangs the upper edge of the cross bar when the fuel supporting member is in place. Between the flange 9 and the back 7 I leave an open throat 11 which is substantially vertical. This permits the ashes which have fallen down from the top to pass through into the ash pit and prevents their clogging and also permits a better circulation of air.

Projecting forwardly from each fuel supporting member is a lug 12 which is located in an opening 13 in the cross bar member. Each lug preferably has a downwardly projecting shoulder 14. In the form shown in Fig. 2 a recess 15 in cross bar 1 is provided to receive this shoulder 14. The bottom of the lug 12 is also preferably inclined downwardly and forwardly as at 16 and the lower wall of the opening 13 is formed so as to cooperate therewith. I may also incline the upper edge 17 of the lug 12 downward and forward as shown in Fig. 1. In the form shown I have provided horizontal passages or notches 18, 18 in the flanges 9, 9 to receive the prongs 19, 19 of the wedge 3. The body of the wedge 3 is preferably tapered slightly as shown in Fig. 5 so as, when it is driven, to force the lug 12 down away from the upper wall of the opening 13 and prevent any lost motion. The prongs 19, 19 are tapered even more sharply than the body of the wedge 3 so that they may be more readily bent over as in Fig. 1 to lock the parts in place. While the prongs take up very little space in the throat 11 I prefer to stop the back 7 on a line with or somewhat above the passages 18, 18 so as to leave a freer passage through the throat for ashes, etc.

A fuel supporting member is assembled on a cross bar by simply moving the fuel supporting member in a horizontal plane so as to insert the lug 12 in an opening 13 as shown in Fig. 4. As soon as the flange 9 strikes the back of the cross bar 1 the fuel supporting member is dropped in place, shoulders 10 and 14 simultaneously engaging the upper edge of the cross bar and the lower edge of the opening 13. The member is then locked in place for instance by a wedge 3 which is then driven in place above the lug 12 and the prongs 19, 19 of the wedge bent over as shown in Fig. 1 or otherwise.

In Fig. 6 the cross bar 20 carries a series of fuel supporting members such as 21 each of which has a lug 22. A wedge 23 locks the parts in place with the shoulder 24 overhanging the upper edge of the cross bar 20. This is distinguished from Fig. 2 simply in the fact that the lug 22 is made longer than in Fig. 1 and its shoulder overstands the forward surface of the cross bar 20 instead

of being let into a recess such as 15 as in Fig. 1 and the bottom of the lug is horizontal and not inclined.

In Fig. 7 the cross bar 25 carries a fuel supporting member, a fragment of which 26, is shown. The lug 27 on the fuel supporting member has an inclined lower face 28 cooperating with a similar inclined surface on the cross bar 25. The locking member 29 in this case is bent upward at the left and the right end bent downward. While I prefer to have the locking member tapered or wedge-shaped as in Fig. 5 so as to draw the parts tightly together it is obvious that they might be locked together by a member 29 such as shown in Fig. 7 without a strict wedging action. There would in this case be more or less loose play however, which is not to be recommended. Inasmuch as the height of the outer end of the lug 27 is greater than the height adjacent the flange 31 it is impossible for the lug to be withdrawn from the cross bar 25 so long as the key or wedge 29 is in place.

From Fig. 6 it will be seen that it is not absolutely essential that the lower face of the lug be inclined since the shoulder 22 may prevent retraction of the lug.

From Fig. 7 it will be seen that if the lower face of the lug is inclined as at 28 it is not absolutely essential that a pronounced shoulder such as 14 in Fig. 1 and 22 in Fig. 6 be provided. I prefer however to provide the inclined surface 16 as well as a shoulder 14 as in Fig. 1. This insures greater security of the parts and a uniform distribution of the strain when in use.

While I prefer to secure the fuel supporting members in place by means of a wedge or key such as shown in Fig. 5 having two prongs 19, 19 integral therewith it is obvious that it is possible to accomplish somewhat similar results by the use of two separate wedges or keys such as 32, 32 as shown in Figs. 8 and 9. In this case a rib 33 may be provided in the upper part of the opening through the cross bar 25 above the lug 27 to keep the keys or wedges 32, 32 apart. The lug 27 may have a rib 34 in place of or supplementing rib 33 to position the keys 32, 32.

The key of Fig. 5 may be made of malleable iron or cut from a bar or sheet of iron or steel. In Fig. 10 I have shown a key 35 which may be readily made from a straight piece of metal, the prongs being formed by bending the ends into the form of a staple. When such a key is used I prefer to provide a rib or ribs such as 33 and 34 to position the prongs of the key more readily.

It will be obvious to one acquainted with this art that the proportions and shape of some of the parts may be altered or varied in accordance with the particular conditions of use to which they may be subjected. The

parts may be heavier in some places and greater in strength and lighter in other places to economize material. It will also be obvious that some of the features may be embodied in dumping grates.

What I claim is:—

1. In a grate, a cross bar member having a series of horizontal openings, removable fuel supporting members having shoulders overstanding the upper edge of said bar and having forwardly projecting lugs located in said horizontal openings and locking members located in said openings and extending over the upper surfaces of said lugs and holding the same down in place.

2. As an article of manufacture a fuel supporting member for a grate bar having a plurality of lateral projections along its upper edge, a heavy heel portion 6 and a broad back portion 7 with horizontal passages 8, 8 between the heel and back portions and said member having vertical passages 11, 11 on opposite sides open at the top and bottom for the purpose specified.

3. A grate bar comprising a cross bar and a series of fuel supporting members detachably secured thereon, each member having a vertical bearing flange 9 extending upwardly and forwardly and terminating in a downturned shoulder 10, and a broad back portion 7 extending considerably below the top of the shoulder 10 and each member having a vertical throat 11 between the flange and the back portion open at the top and bottom.

4. As an article of manufacture, a fuel supporting member for a grate bar comprising a body 2 having lateral projections 4, 4 along its upper edge, a bearing flange 9, a broad back portion 7 extending below the top of the flange 9 and said member having a vertical throat 11 between the flange and the back portion open at the top and bottom.

5. As an article of manufacture, a detachable fuel supporting member for a grate bar comprising a body 2 having a vertical bearing flange 9 extending upwardly and forwardly and terminating in a downturned shoulder 10, a broad back portion 7 with a cutting edge at its lower end below the top of the shoulder 10 and said member having a vertical throat 11 between the bearing flange and the back portion open at the top and bottom.

6. As an article of manufacture, a detachable fuel supporting member for a grate bar comprising a body portion 2 having a flange 9, a forwardly projecting downturned shoulder 10, a forwardly projecting lug 12 and a downwardly projecting shoulder 14 at the outer end of said lug said flange 9 extending below said lug substantially as described and for the purpose specified.

7. A detachable fuel supporting member

for a grate bar comprising a body portion 2 having a flange 9 with a horizontal passage 18, a lug projecting forward from said flange adjacent said passage and a broad back member 7 terminating above the line of said passage and leaving a vertically open throat 11.

8. A grate bar comprising a cross bar member having a series of openings, a series of fuel supporting members detachably secured to said bar, each having a forwardly and downwardly projecting lug extending into one of the openings in said bar and a downwardly projecting shoulder engaging the upper edge of said bar and a wedge driven through each opening and holding down the lug therein.

9. A grate bar comprising a cross bar member having a series of openings and a series of separate fuel supporting members each having a downwardly projecting shoulder 10 and a forwardly projecting lug 12 seated in one of said openings and a wedge driven in each opening above the lug therein and having its rear end bent over to lock the members in place.

10. A grate bar comprising a cross bar having a series of openings, a series of fuel supporting members secured thereon and each having a forwardly projecting lug located in one of said openings and a two-pronged wedge in each opening having its ends bent over and locking the members in place.

11. In a grate bar, a cross bar having a series of openings therein and a series of separate detachable fuel supporting members each having a lug located in one of said openings and a wedging prong in each opening on each side of each member above its lug and locking the members in place.

12. In a grate bar, a cross bar having a series of openings and fuel supporting members having lugs located in said openings and wedges in the openings locking the lugs in place each wedge having two bent prongs, the body of each wedge being slightly tapered and the prongs being tapered more sharply whereby the lugs are forced against the walls of the openings by the driving of the wedges and the ends of the wedges may be more easily bent over.

13. In a grate, a cross bar having horizontal openings therein, a series of fuel supporting members having downwardly projecting shoulders overstanding the upper edge of the bar and each having a lug projecting into one of said openings, said lugs having downwardly and forwardly inclined surfaces engaging correspondingly inclined faces in said openings and means in the openings for locking said lugs in said openings.

14. In a grate, a cross bar having openings and an upper supporting edge and

a series of fuel supporting members resting upon said supporting edge and having shoulders overstanding the edge thereof and lugs projecting into said openings and vertical side flanges 9, 9 and broad back portions 7, 7 leaving vertically open throats 11, 11 between the flanges and back portions and keys in the openings locking said members in place.

10 15. In a grate, a cross bar having a series of horizontal openings, removable fuel supporting members having shoulders overstanding the upper edge of said bar and having forwardly projecting lugs located in said openings, said lugs having terminal shoulders extending substantially at right angles to the lugs and locking wedges located in said openings and pressing against said lugs for holding them in place.

20 16. A grate bar fuel supporting member comprising a body having lateral projections along the top, a broad back portion 7 and a vertical flange 9 leaving an open throat 11, a downwardly projecting shoulder 10 and a forwardly projecting lug beneath said shoulder said flange extending below said lug.

25 17. A grate bar fuel supporting member

comprising a body having lateral projections along the top, a broad back portion 7 and a vertical flange 9 leaving an open throat 11, a downwardly projecting shoulder 10 and a forwardly and downwardly projecting lug beneath said shoulder said flange extending below said lug.

35 18. As an article of manufacture, a fuel supporting member for a grate bar comprising a body having a forwardly and downwardly projecting supporting shoulder 10 near the top, a forwardly and downwardly projecting locking lug 12 near the bottom and a vertical bearing member 9 in rear thereof extending below said lug.

45 19. In a grate, a cross bar member having a bearing edge and a series of horizontal openings, removable fuel supporting members having shoulders overstanding the bearing edge of said bar and having forwardly projecting lugs located in said openings and locking members located in said openings and pressing against the lugs for holding the lugs in place.

HENRY B. EELLS.

Witnesses:

ROBT. S. ALLYN,
E. BRADFORD.