



(19) **United States**

(12) **Patent Application Publication**
Barney et al.

(10) **Pub. No.: US 2012/0122575 A1**

(43) **Pub. Date: May 17, 2012**

(54) **INTERACTIVE GAMING SYSTEM AND METHOD USING MOTION-SENSITIVE INPUT DEVICE**

(60) Provisional application No. 60/184,128, filed on Feb. 22, 2000.

Publication Classification

(75) Inventors: **Jonathan A. Barney**, Newport Beach, CA (US); **Denise Chapman Weston**, Wakefield, RI (US)

(51) **Int. Cl.**
A63F 13/00 (2006.01)
A63F 9/24 (2006.01)

(73) Assignee: **Creative Kingdoms, LLC**, Wakefield, RI (US)

(52) **U.S. Cl.** **463/31; 463/36**

(21) Appl. No.: **13/312,916**

(57) **ABSTRACT**

(22) Filed: **Dec. 6, 2011**

A wireless input device for playing an interactive motion-sensitive game using a wireless-compatible game console in which a virtual play environment is represented through one or more computer-animated visual, aural or tactile effects is provided wherein game play is conducted by moving, shaking, twisting, waving or pointing the input device in a particular manner. The input device can include motion-sensitive circuitry and/or command circuitry for generating control signals and/or an effects generator and associated control circuitry to enable the input device to selectively generate at least one visual, aural or tactile effect comprising sound, lighting or vibration. The input device can include a wireless transceiver for providing two-way wireless communication with the wireless-compatible game console. An optional display screen displays short text messages received through wireless communications with the wireless-compatible game console.

Related U.S. Application Data

(60) Continuation of application No. 13/231,813, filed on Sep. 13, 2011, which is a continuation of application No. 12/261,864, filed on Oct. 30, 2008, now Pat. No. 8,089,458, which is a division of application No. 10/954,025, filed on Sep. 29, 2004, now Pat. No. 7,445,550, which is a continuation-in-part of application No. 10/397,054, filed on Mar. 25, 2003, now Pat. No. 7,500,917, which is a continuation-in-part of application No. 09/792,282, filed on Feb. 22, 2001, now Pat. No. 6,761,637.

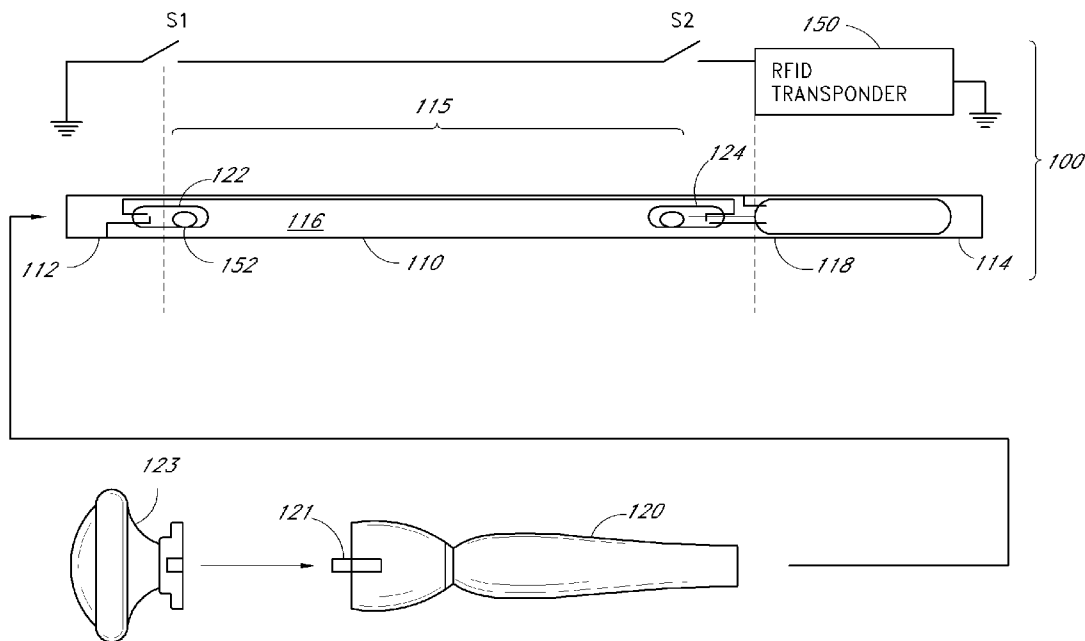
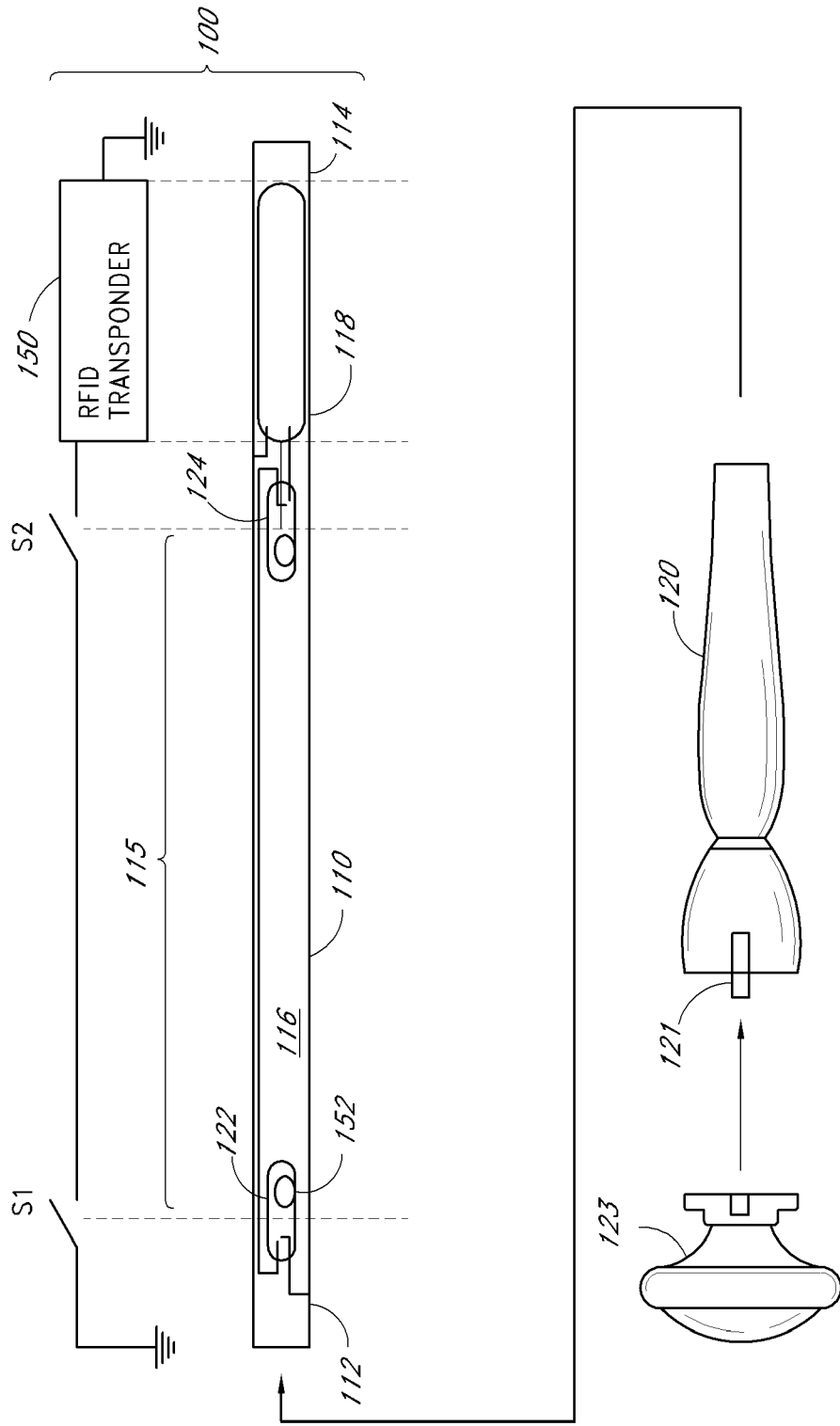

FIG. 1



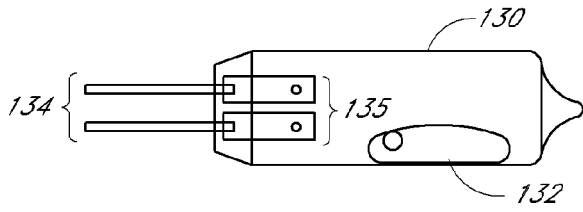

FIG. 2A

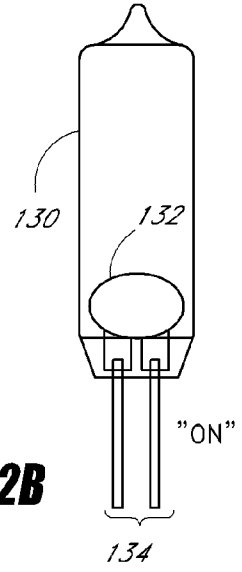

FIG. 2B

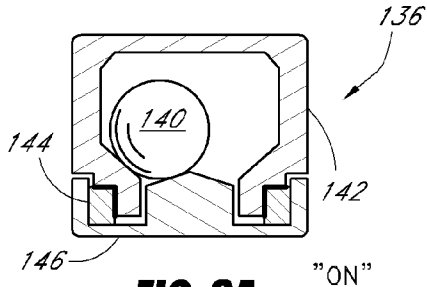

FIG. 3A

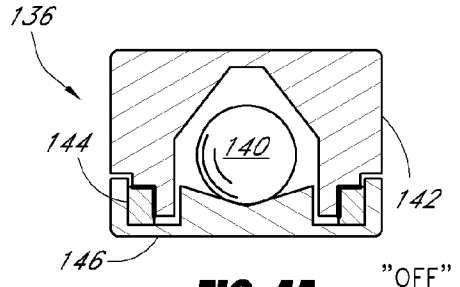

FIG. 4A

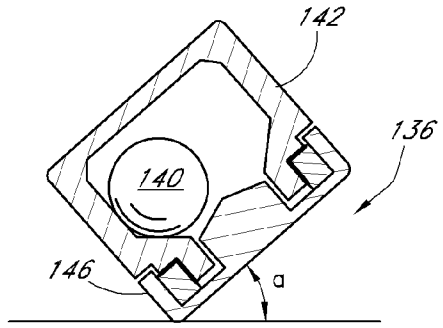

FIG. 3B

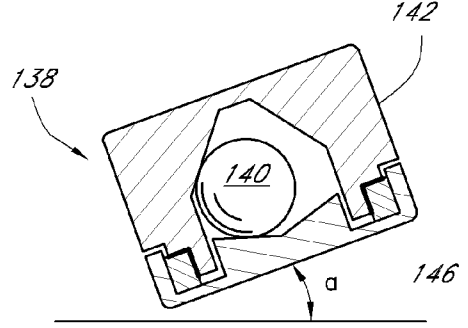

FIG. 4B

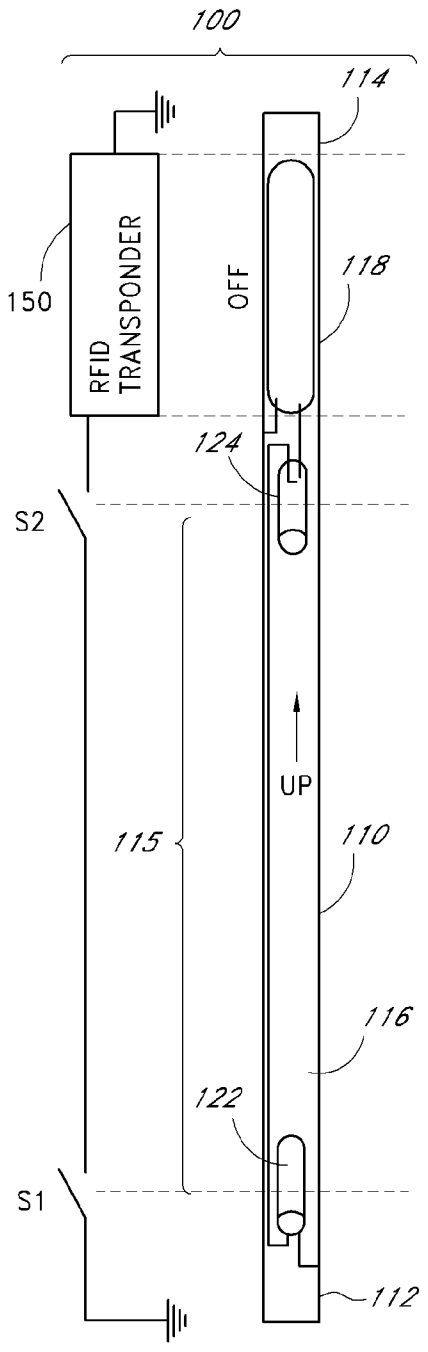

FIG. 5A

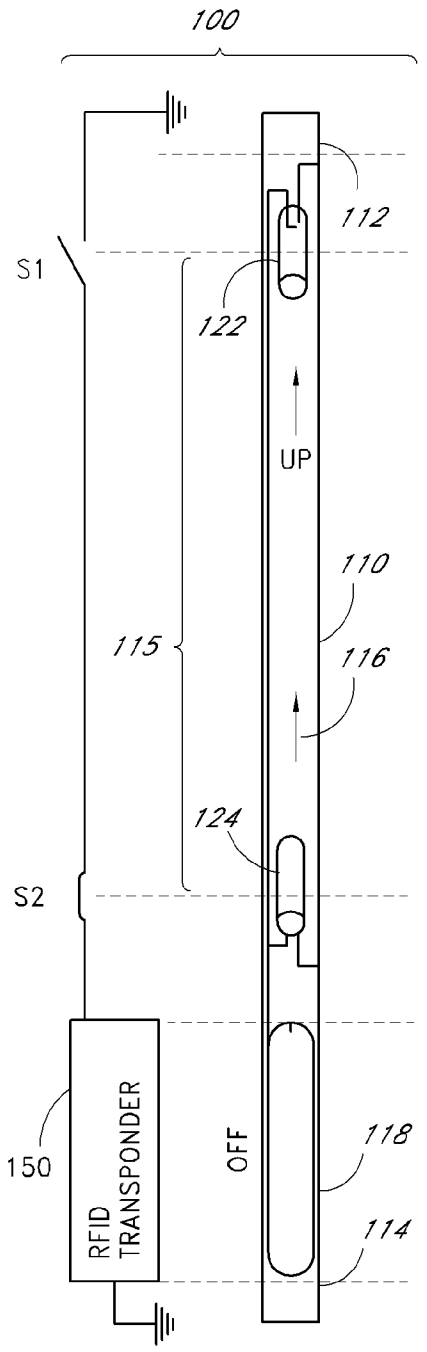

FIG. 5B

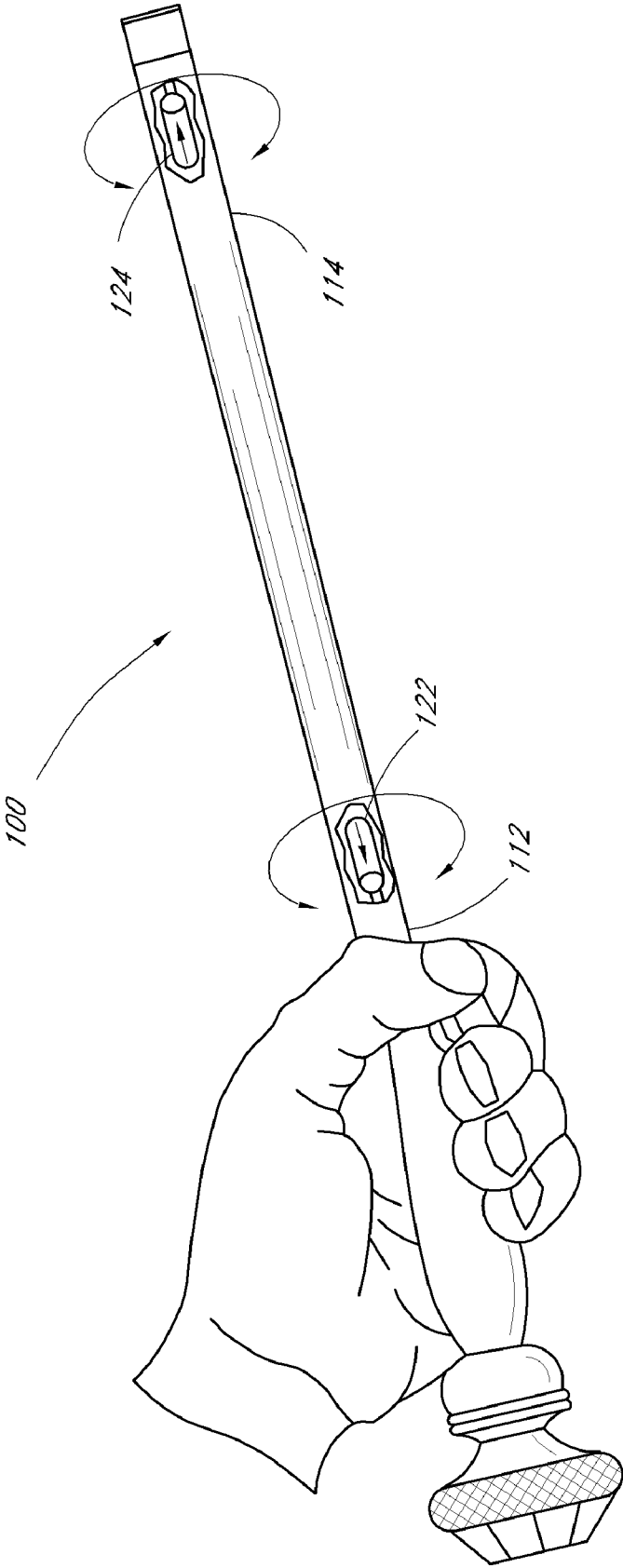
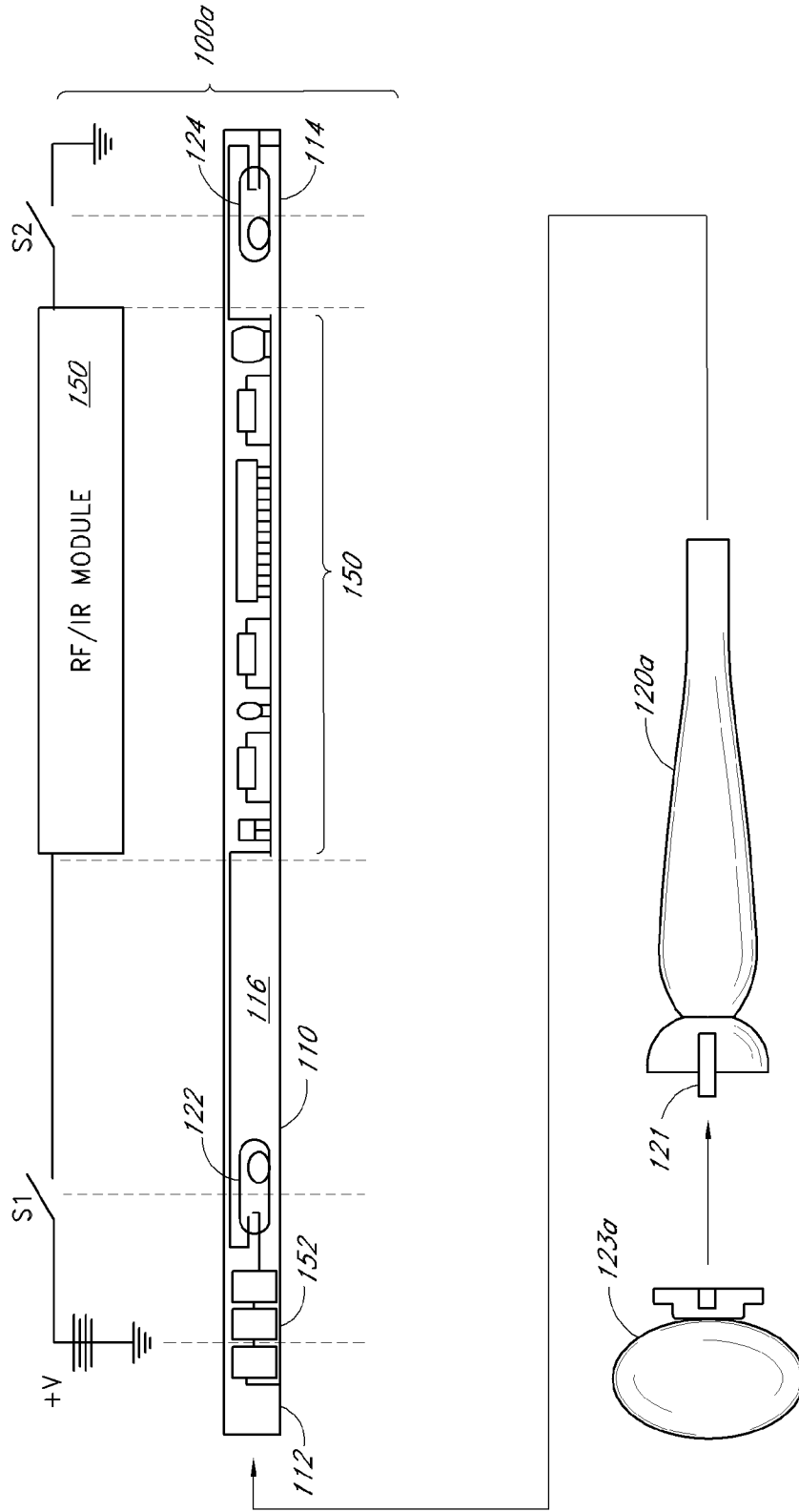

FIG. 6

FIG. 7



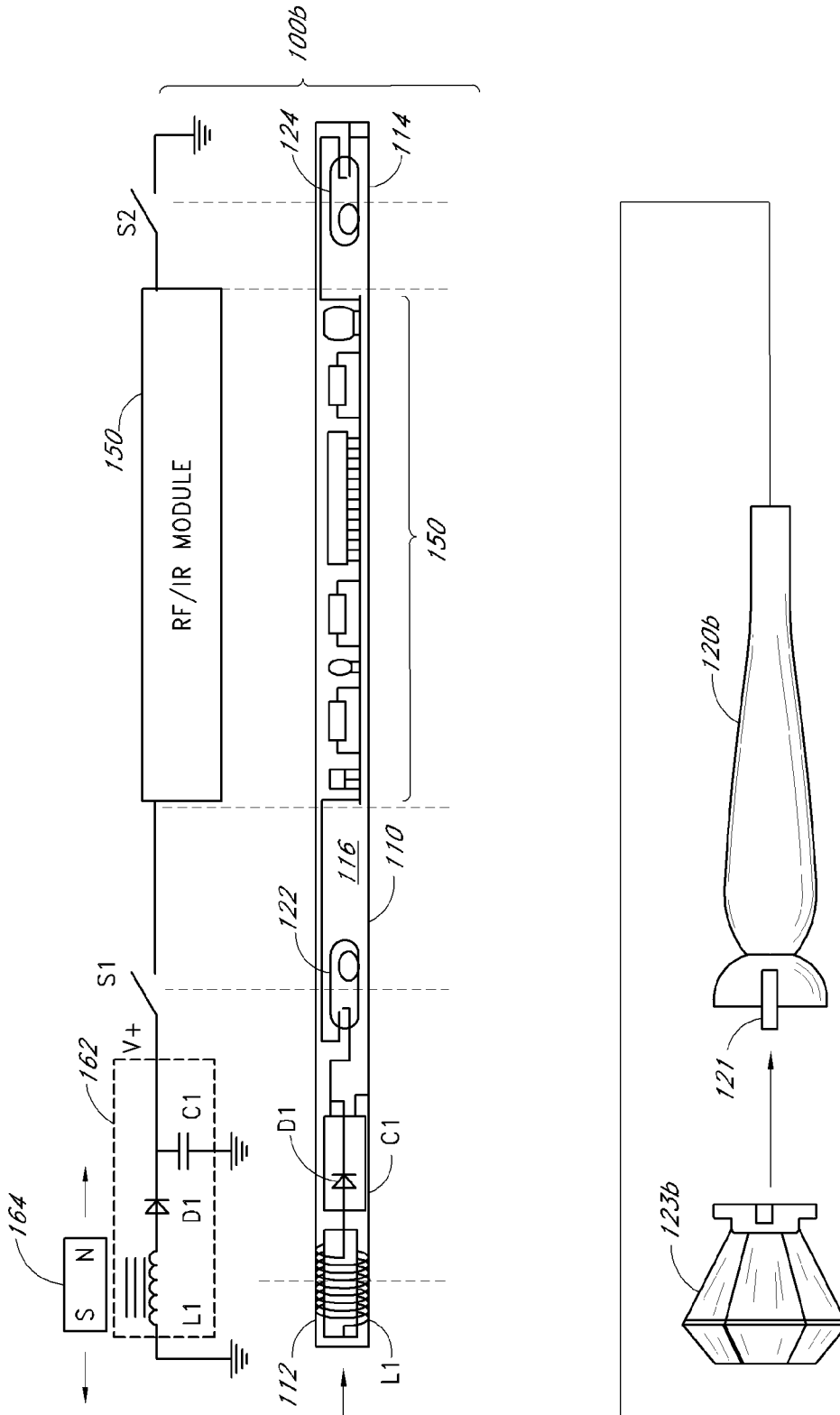

FIG. 8

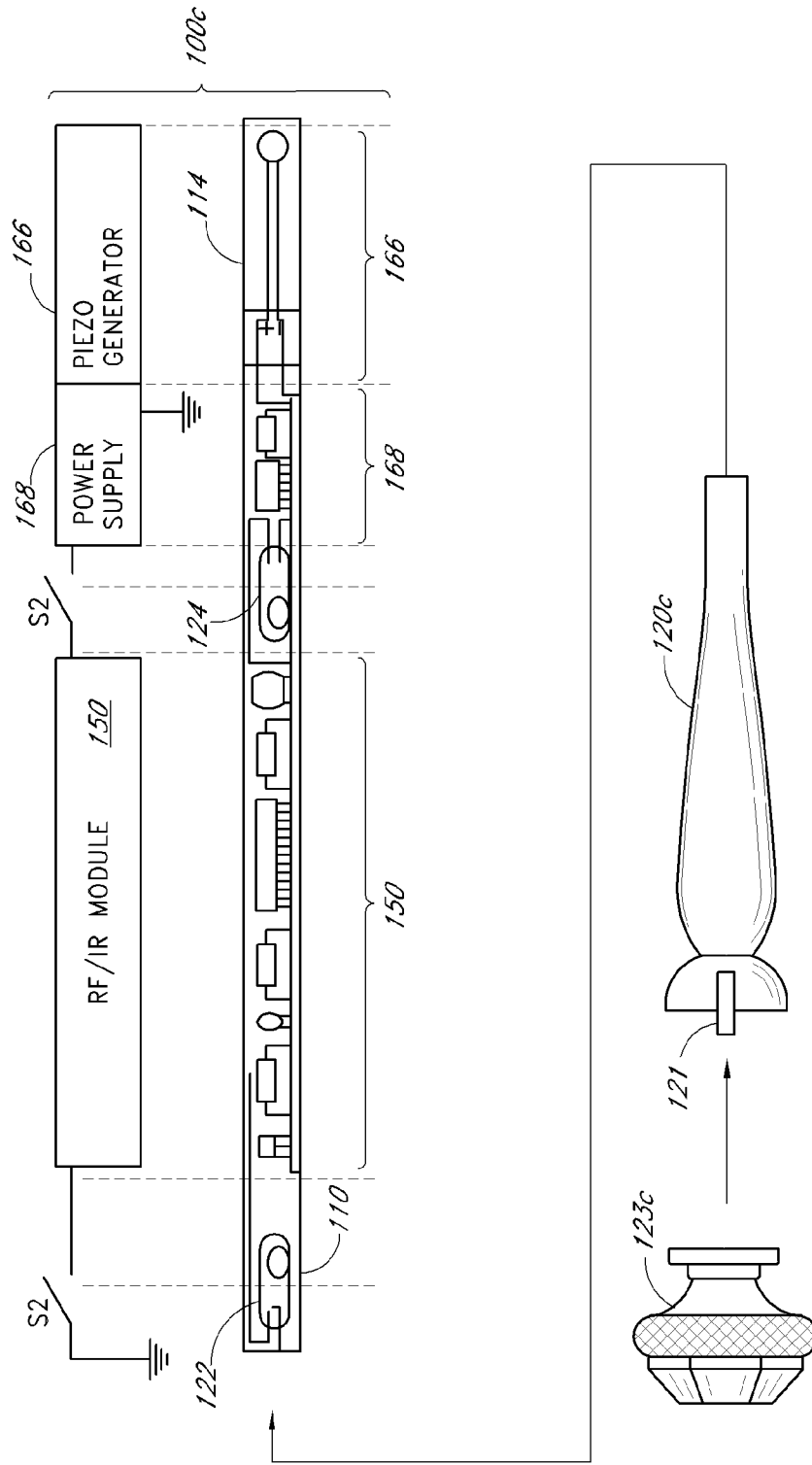

FIG. 9

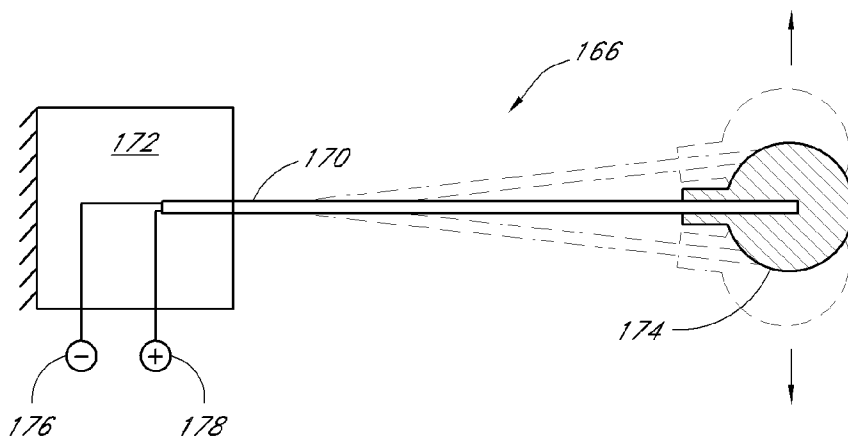

FIG. 10

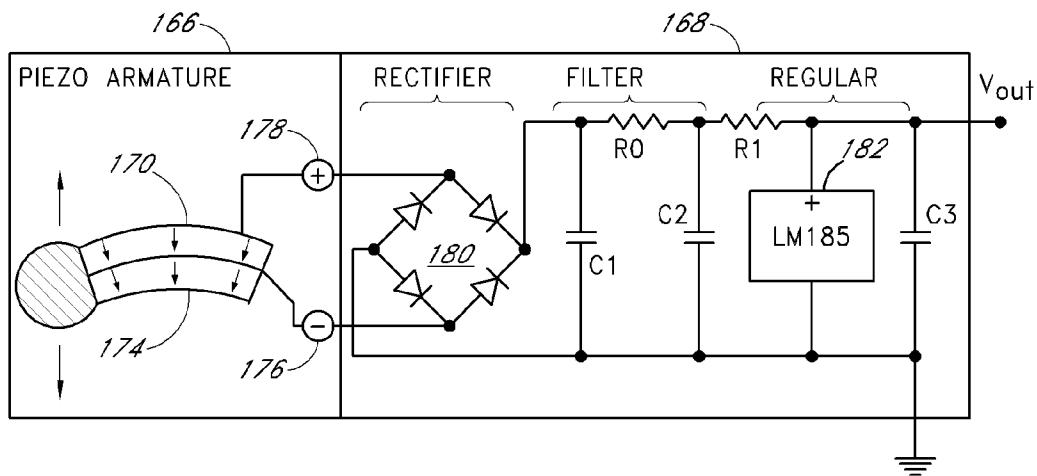

FIG. 11

FIG. 12

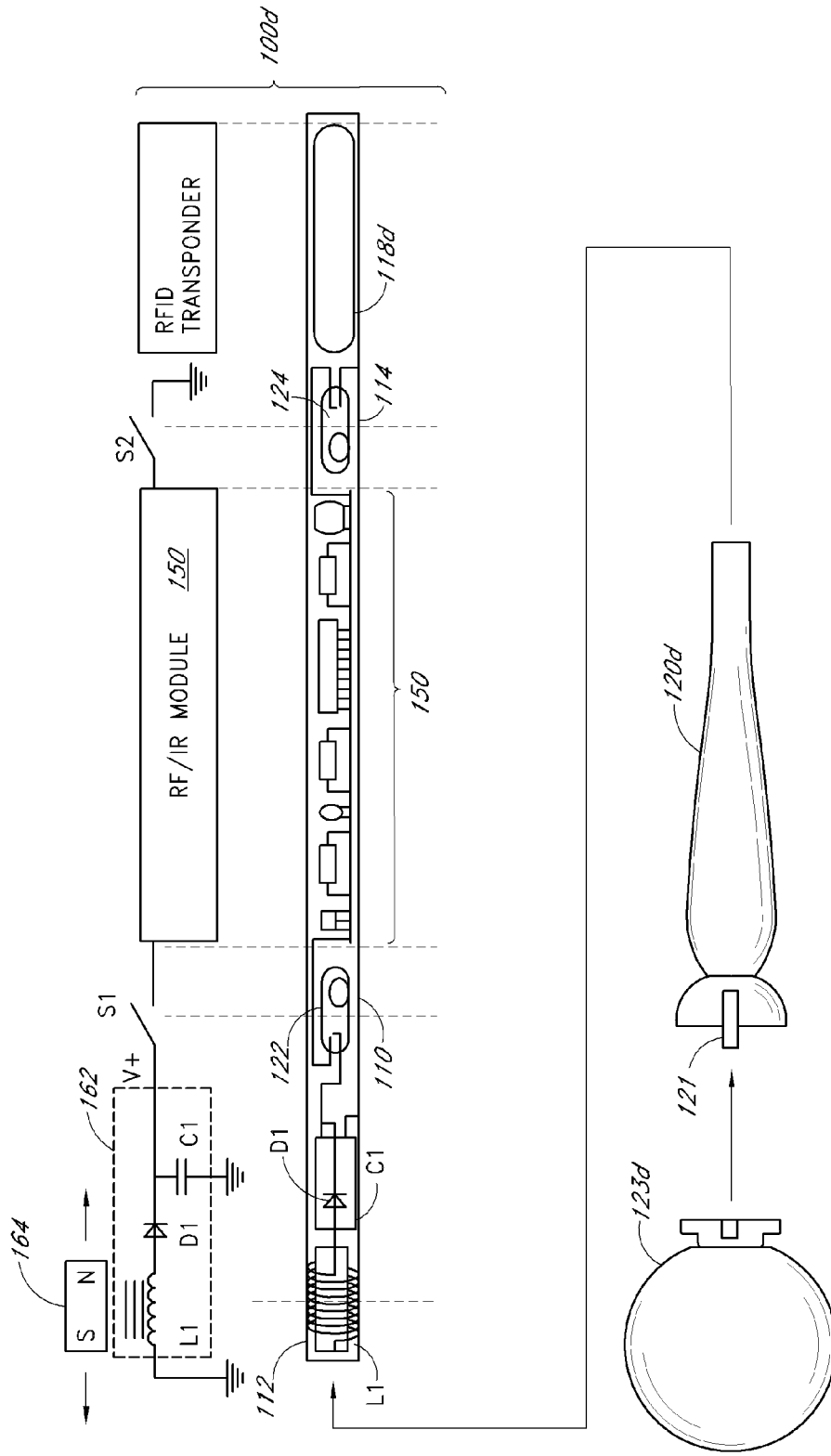
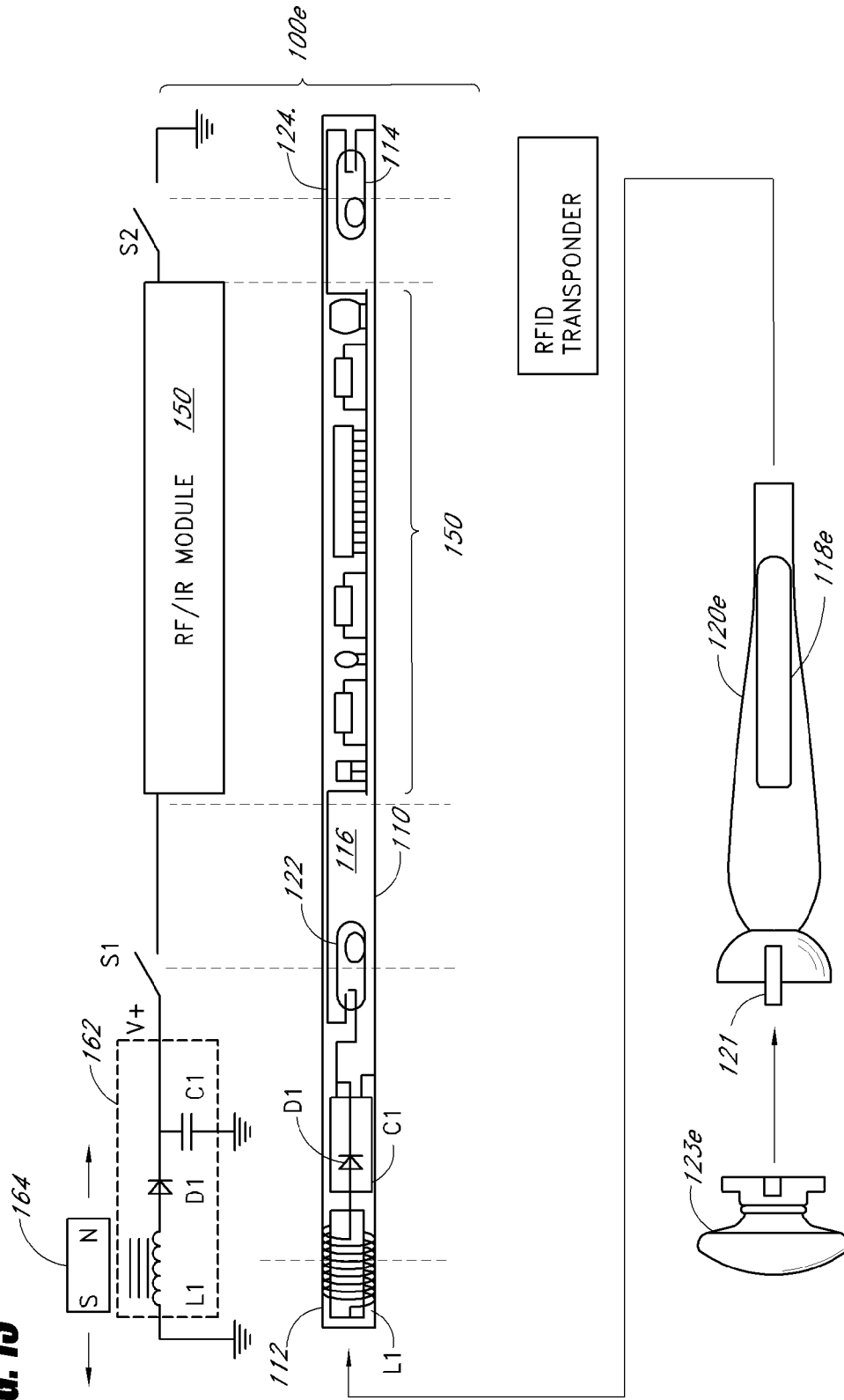

FIG. 13



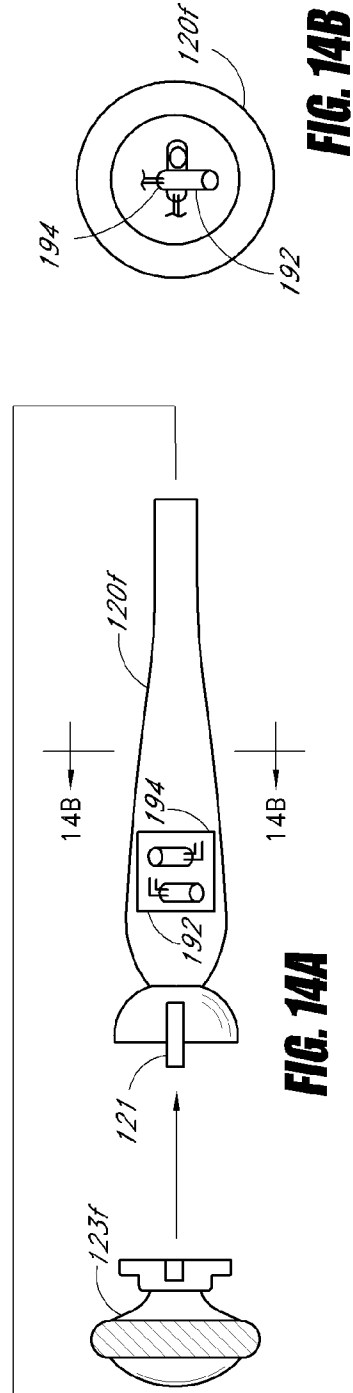
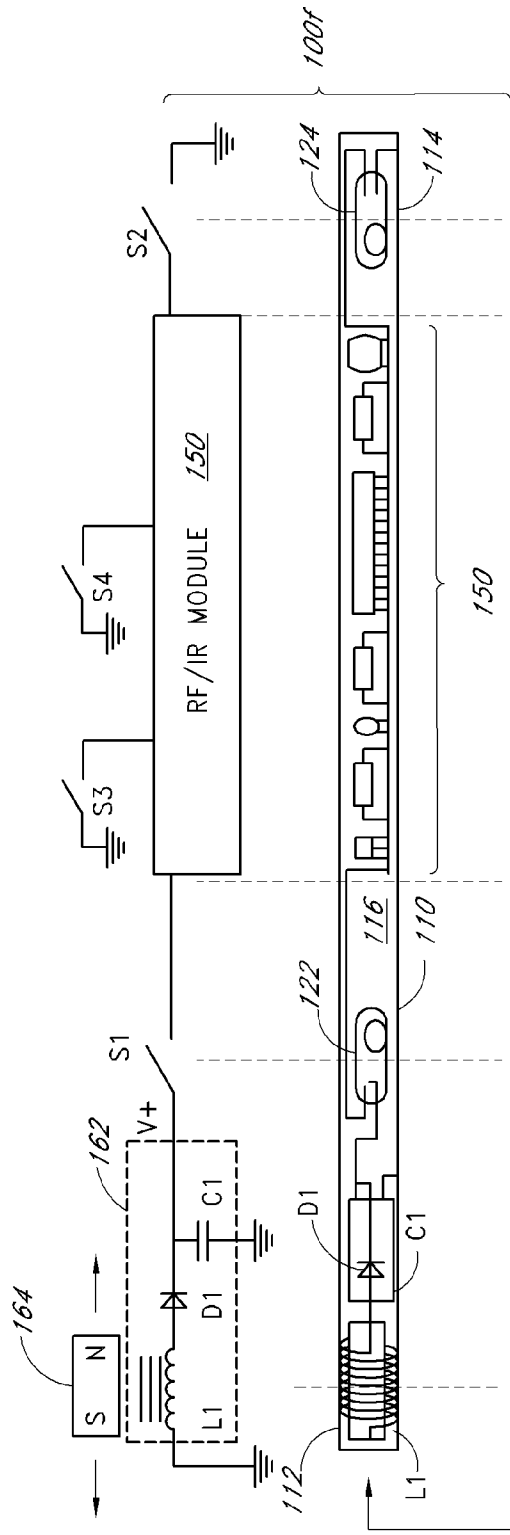

FIG. 14B

FIG. 14A

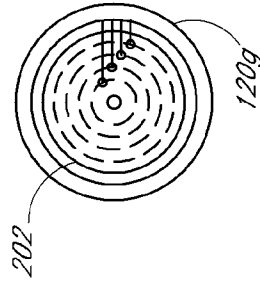
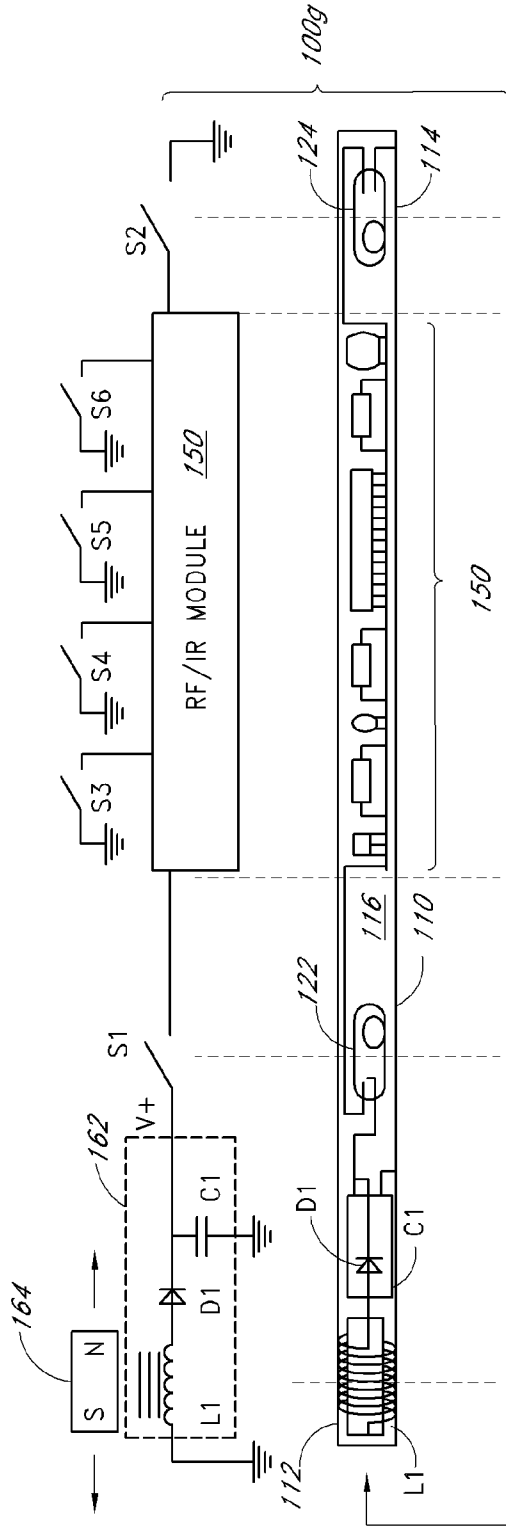

FIG. 15B

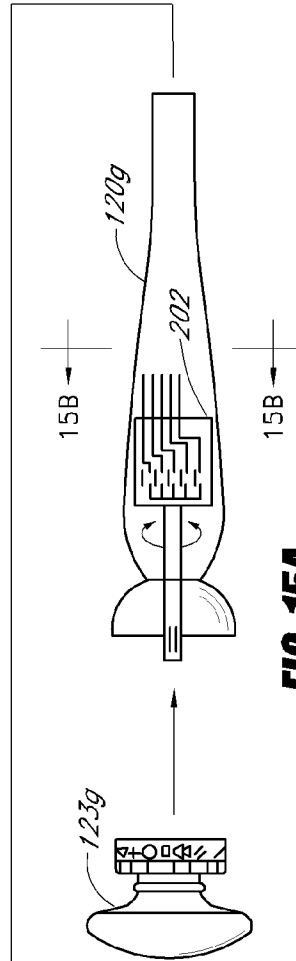

FIG. 15A

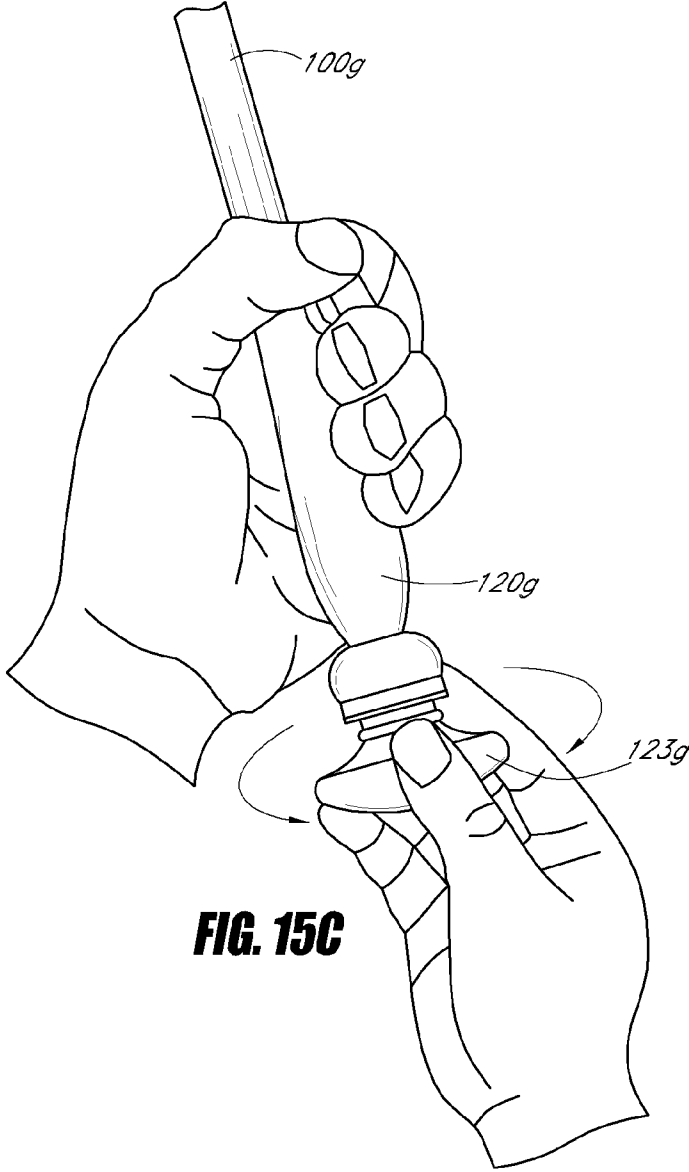

FIG. 15C

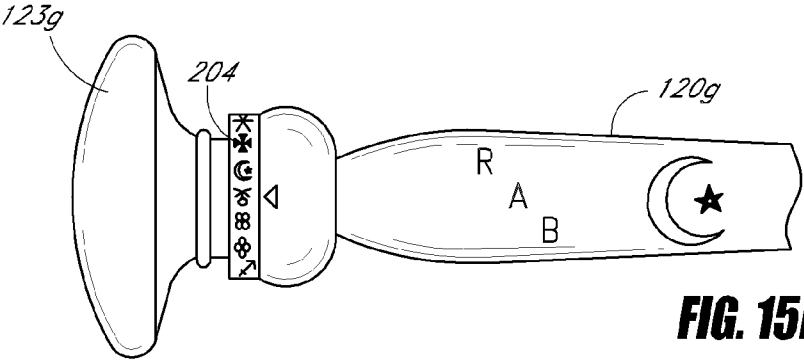

FIG. 15D

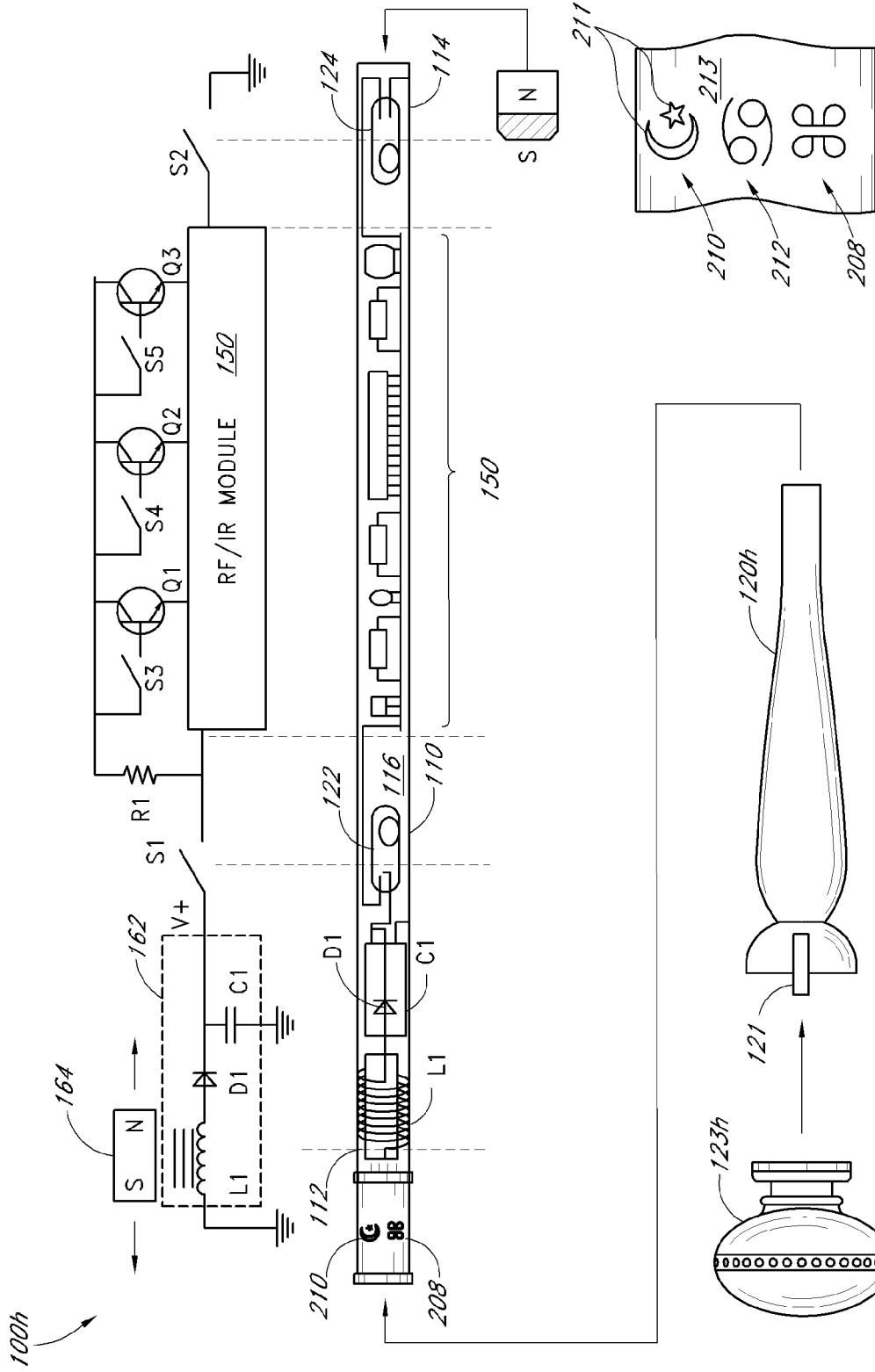

FIG. 16B

FIG. 16A

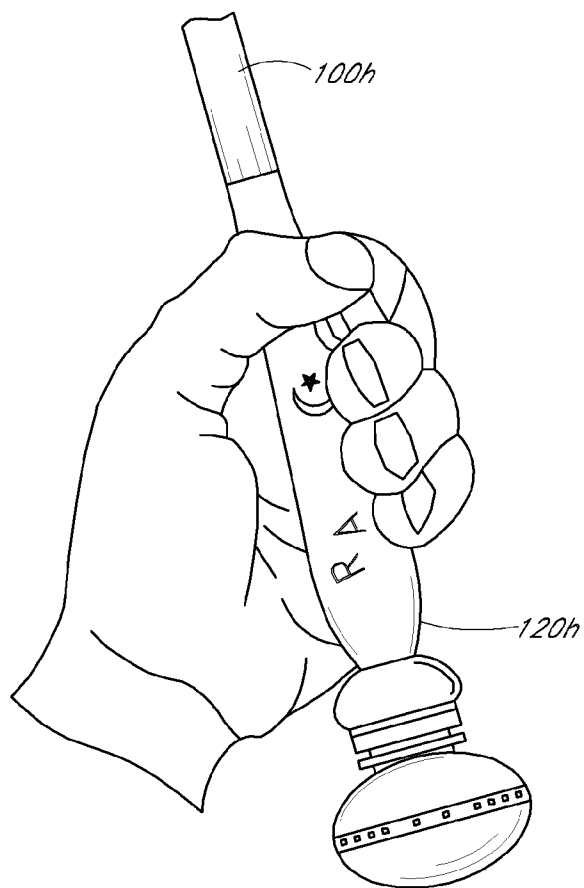

FIG. 16C

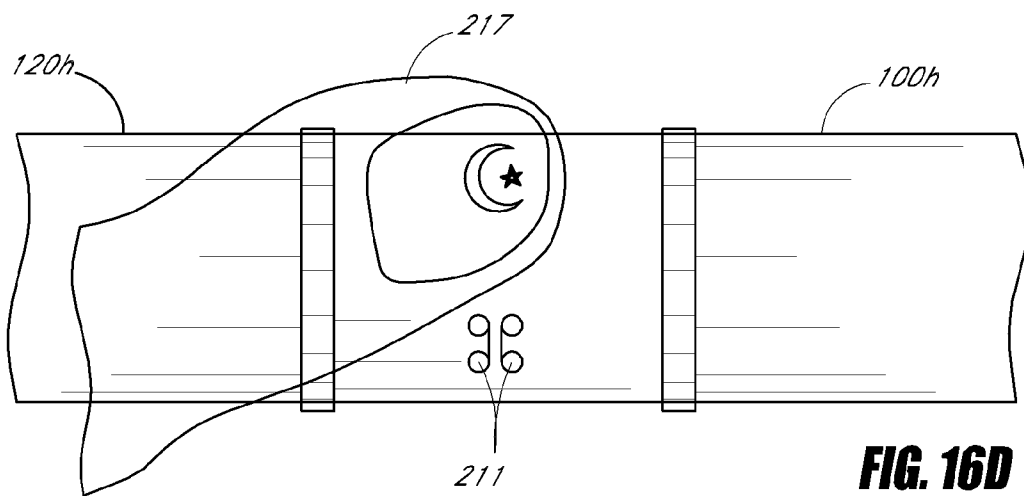

FIG. 16D

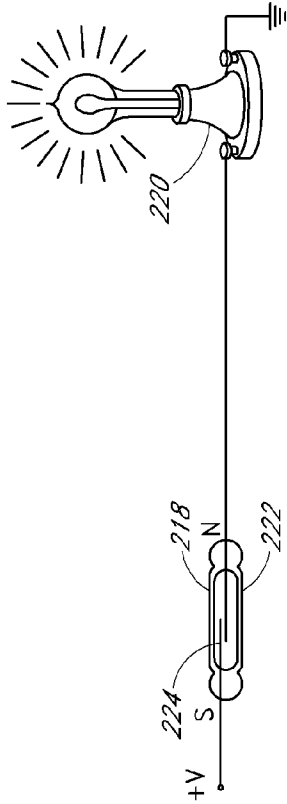

FIG. 17A

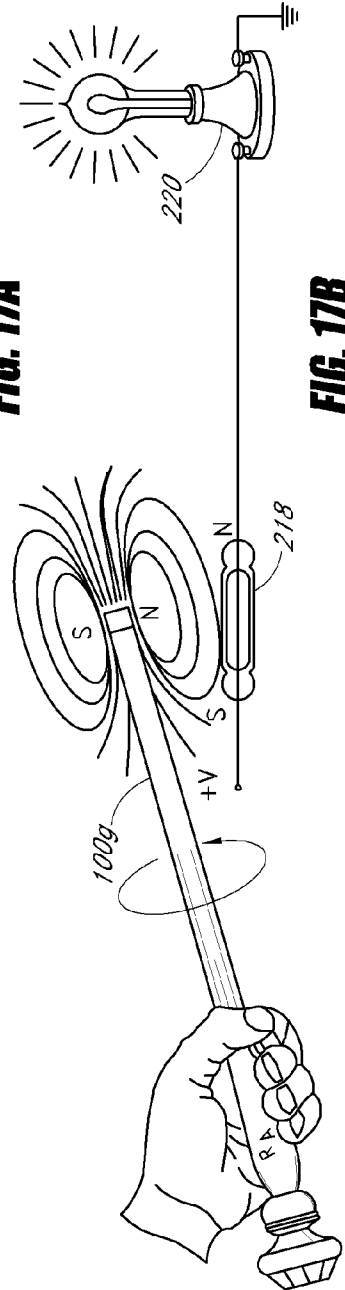

FIG. 17B

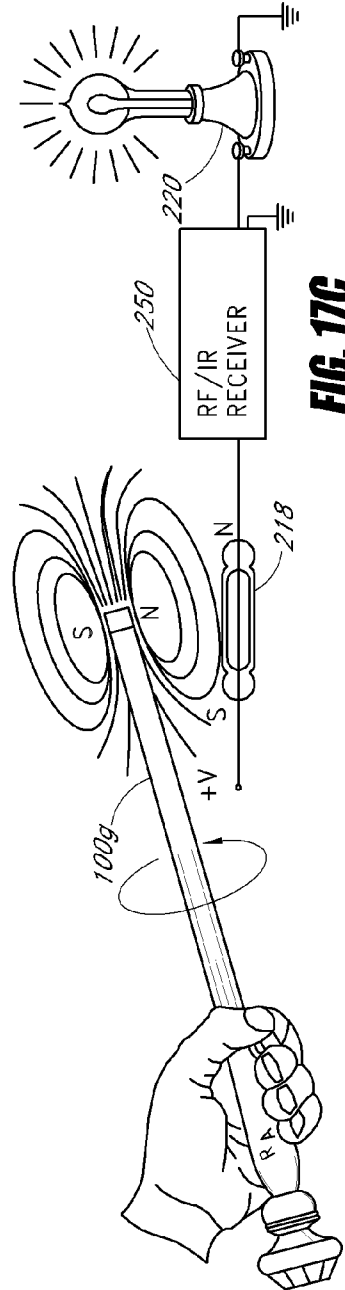

FIG. 17C

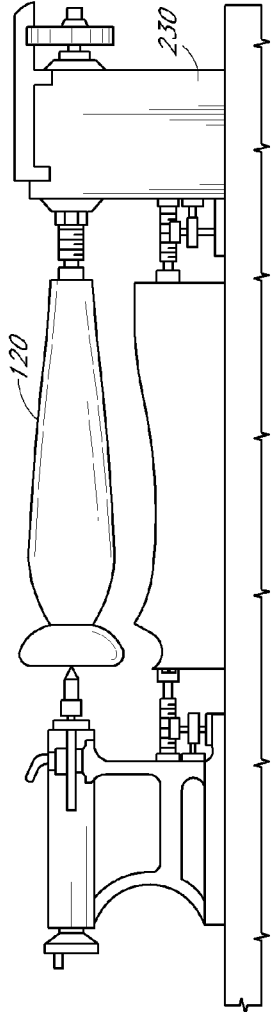

FIG. 18A

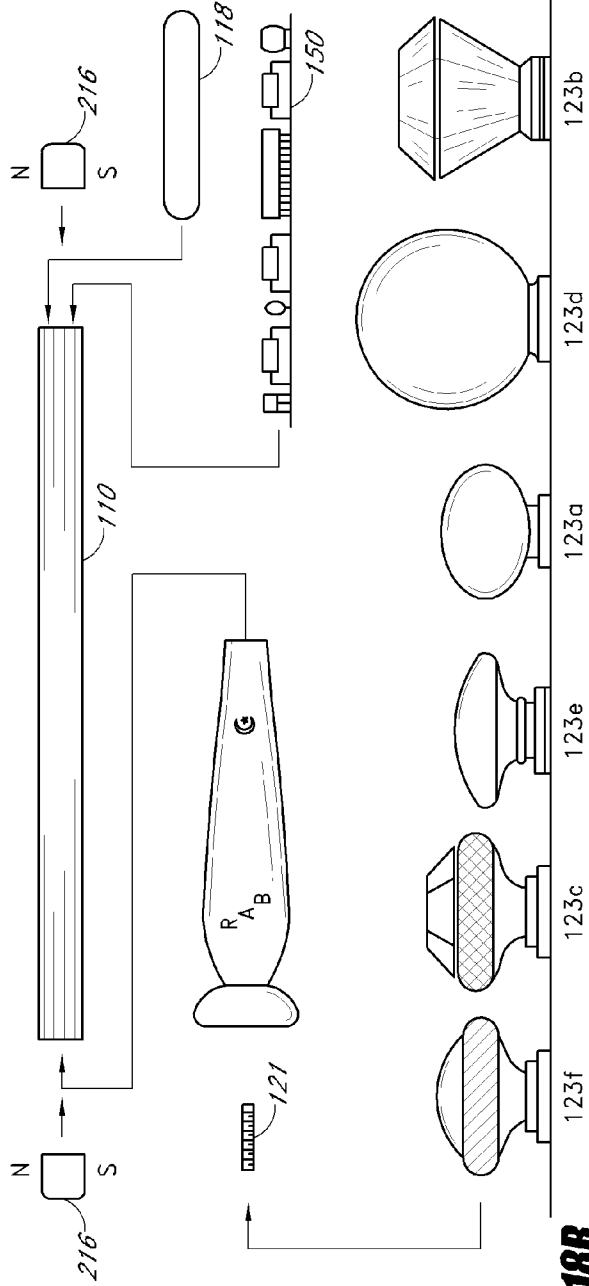
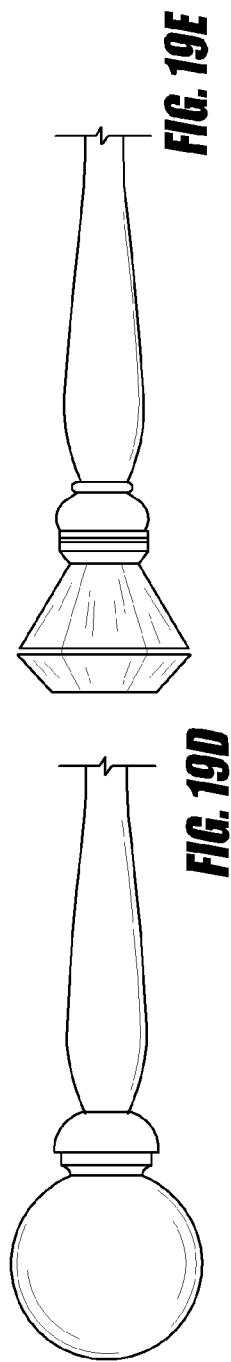
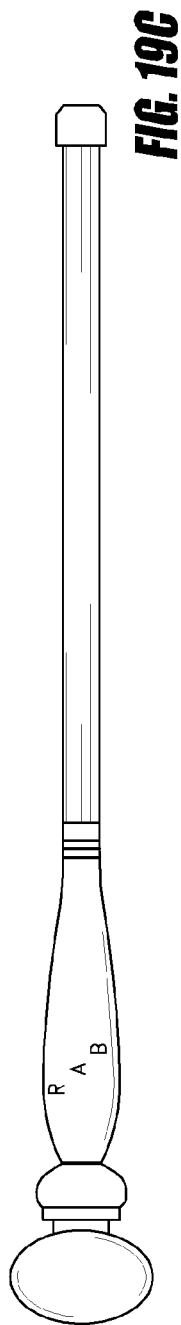
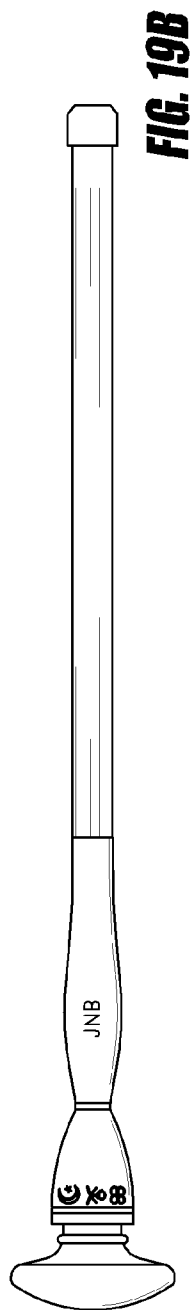
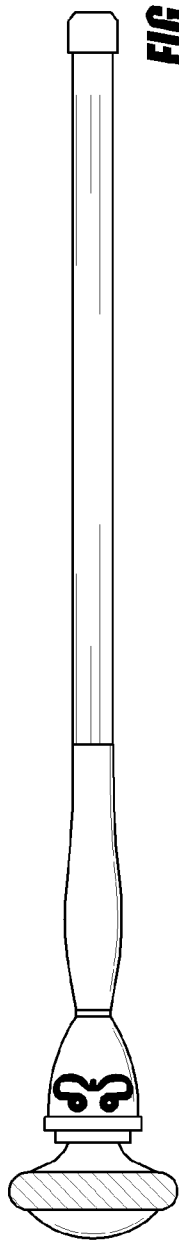

FIG. 18B



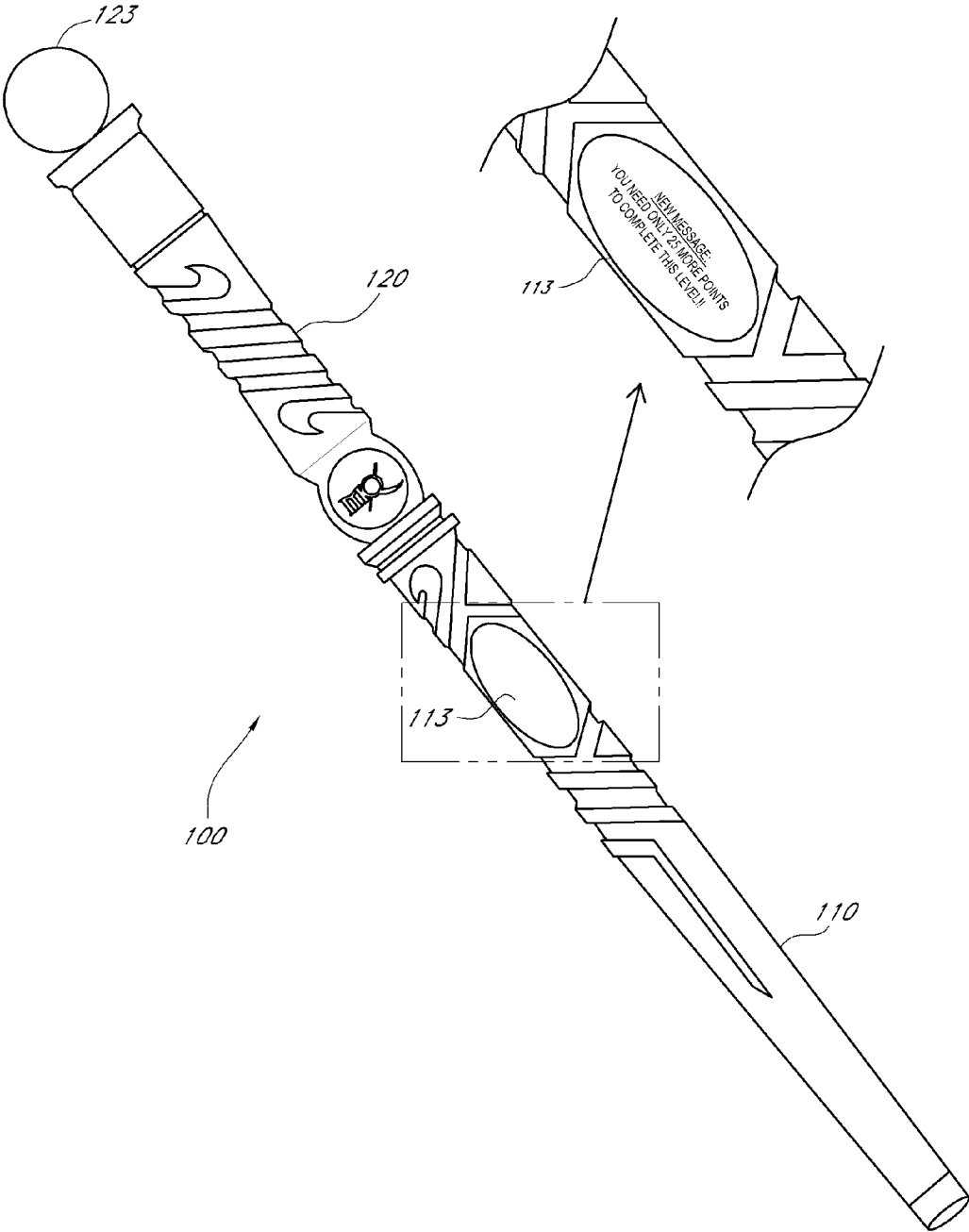

FIG. 19G

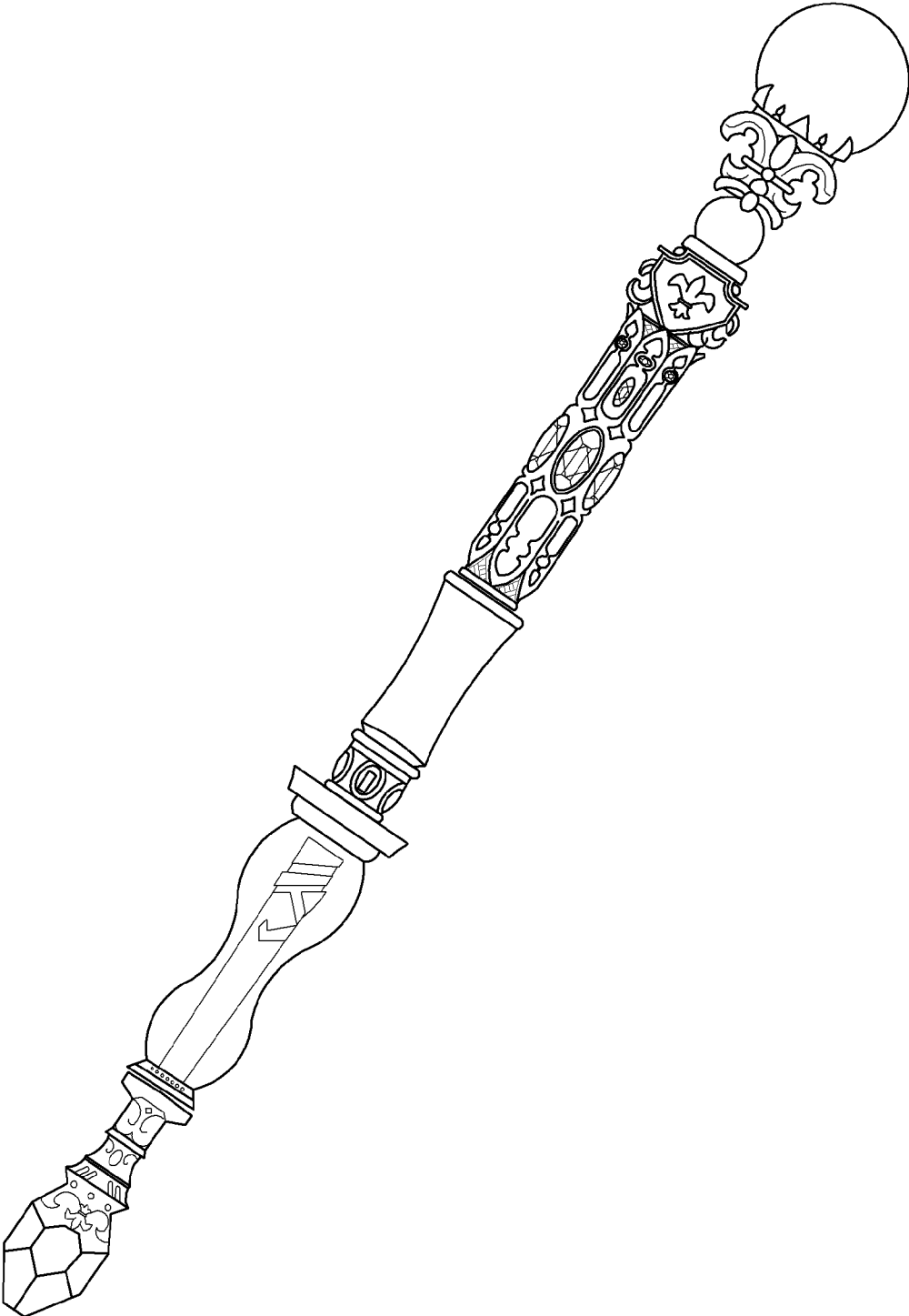

FIG. 19H

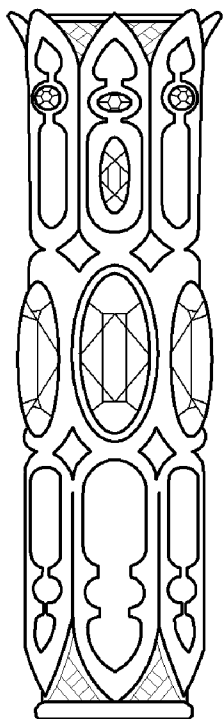

FIG. 19I

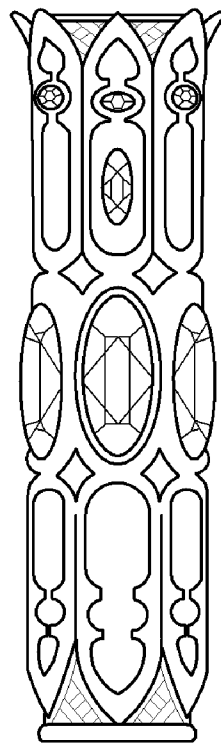

FIG. 19J

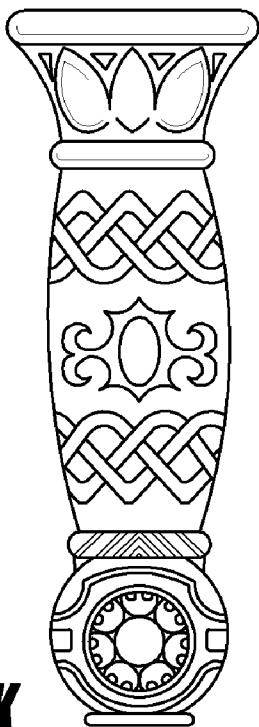

FIG. 19K

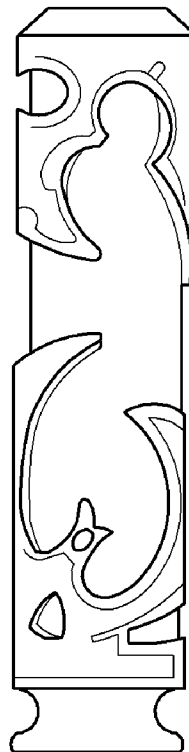

FIG. 19L

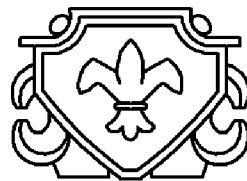

FIG. 19M

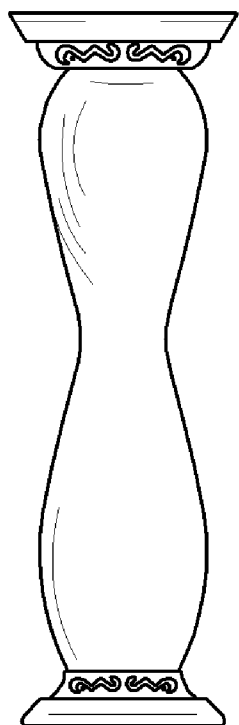

FIG. 19N

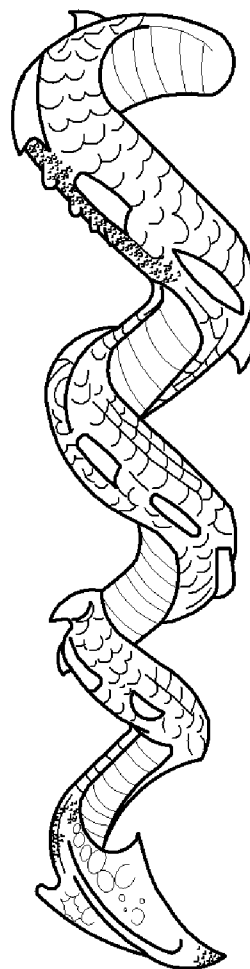

FIG. 19O

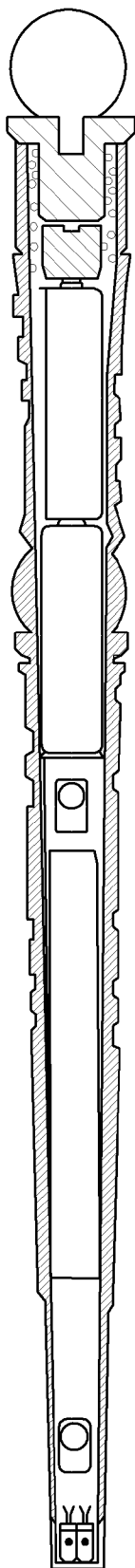

FIG. 19P

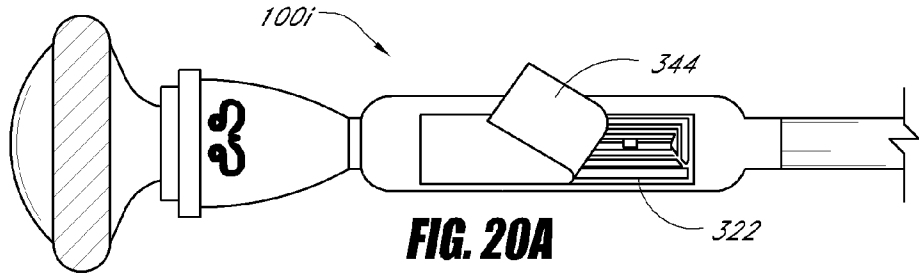

FIG. 20A

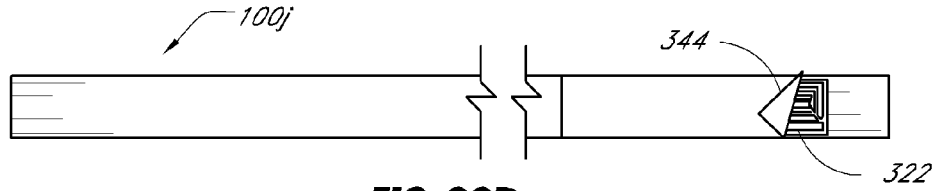

FIG. 20B

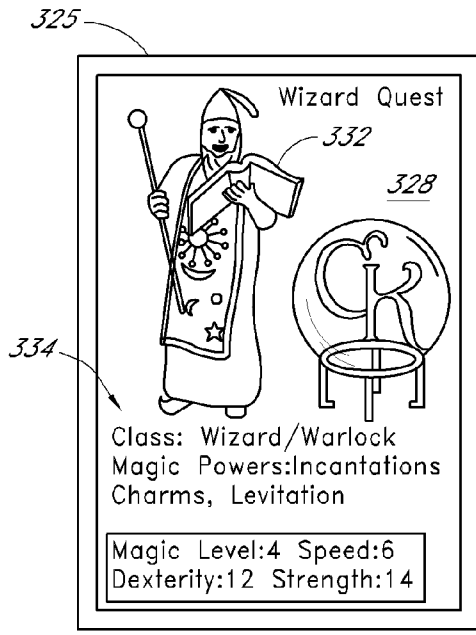

FIG. 20C

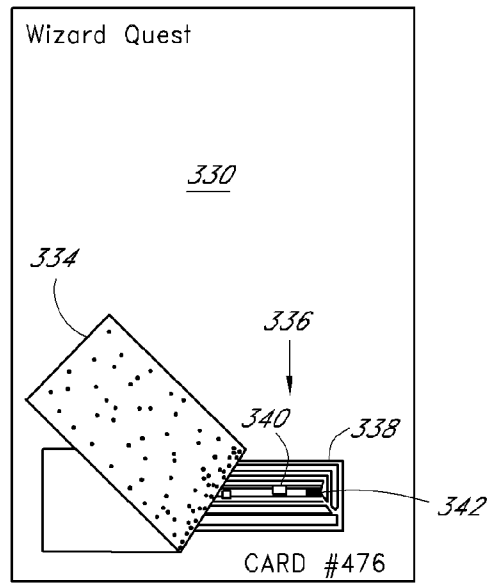

FIG. 20D

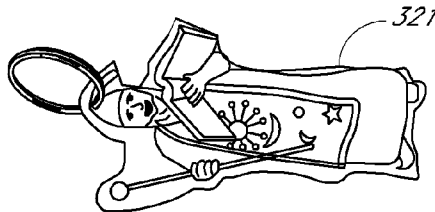

FIG. 20E

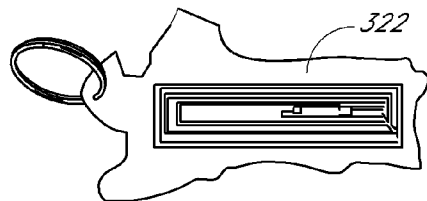

FIG. 20F

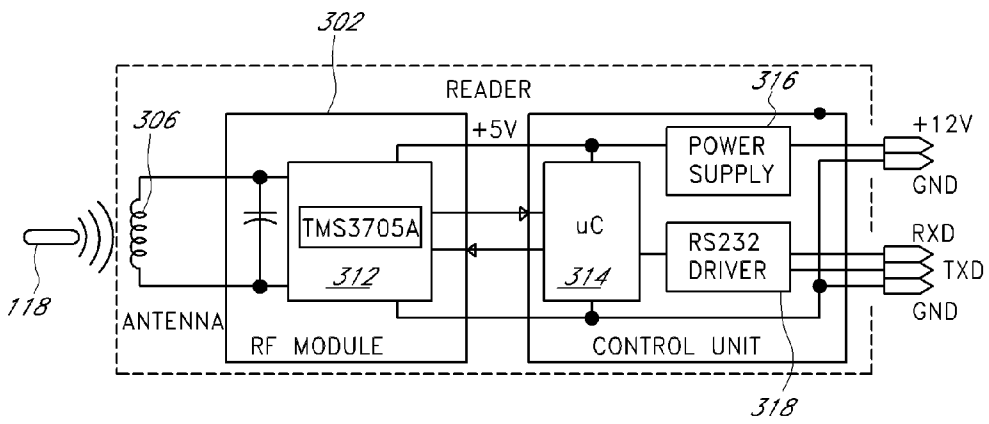
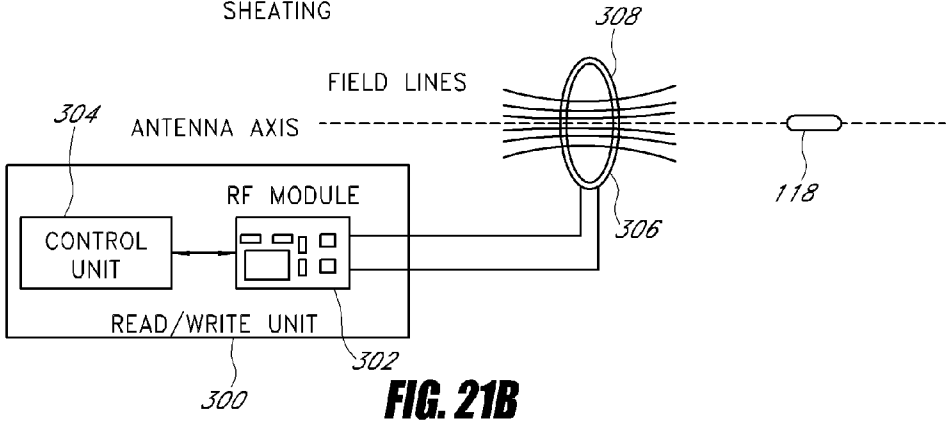
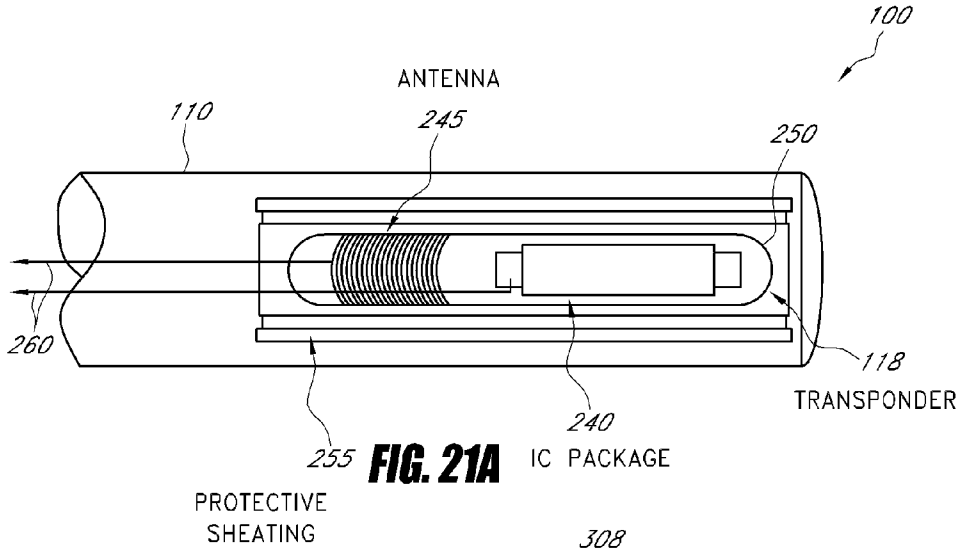
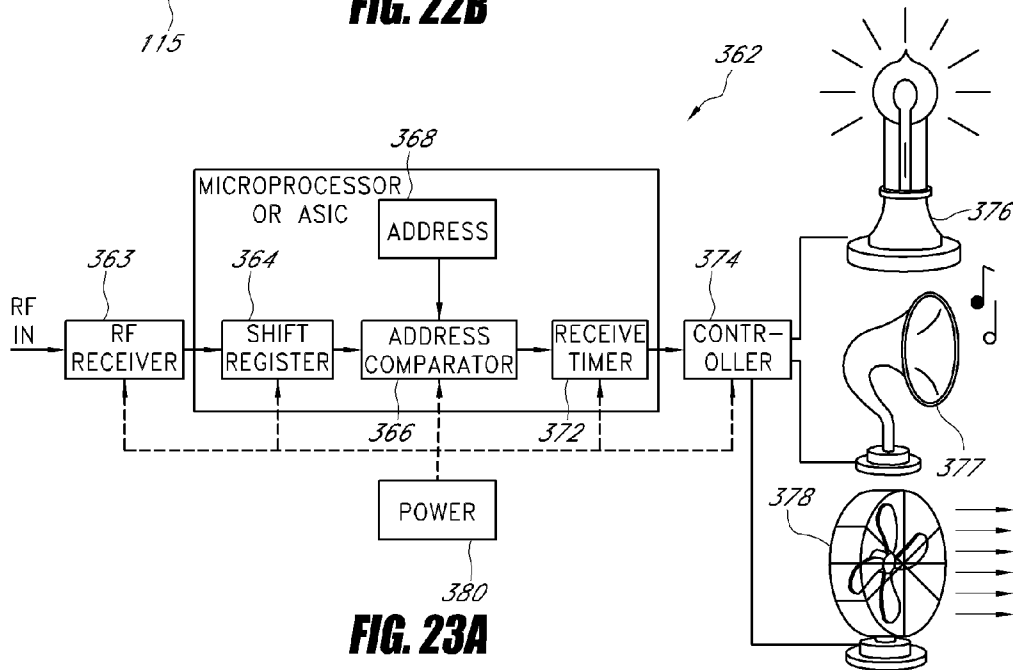
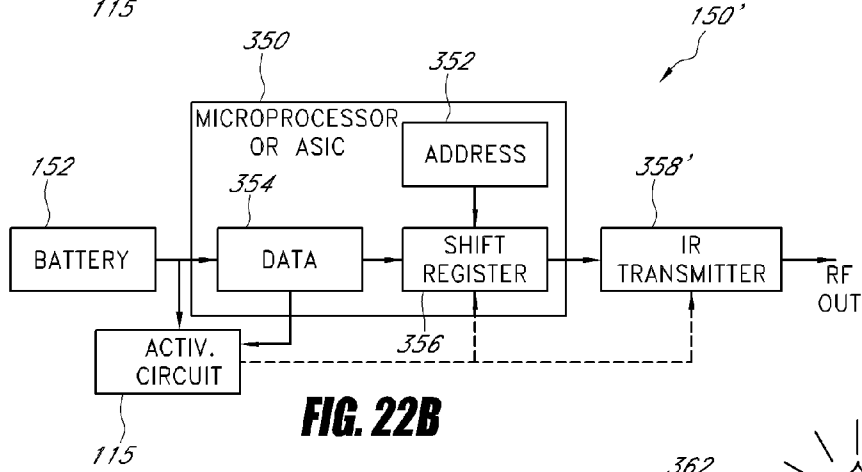
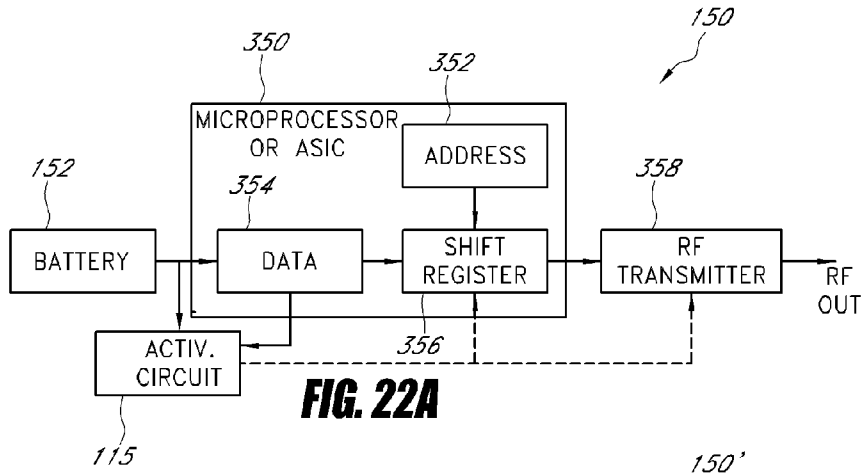

FIG. 21C



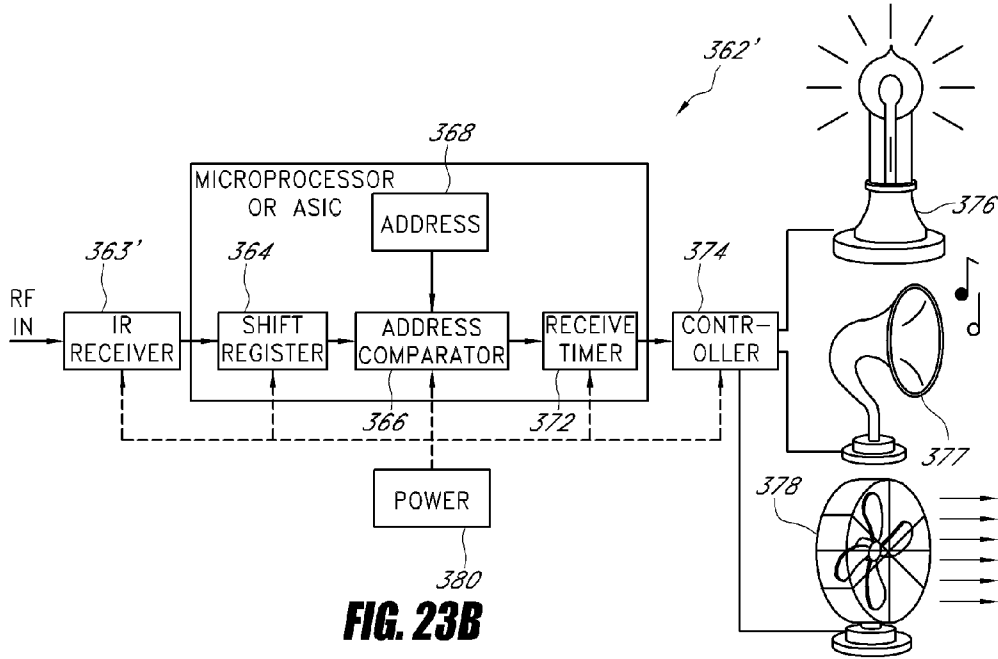

FIG. 23B

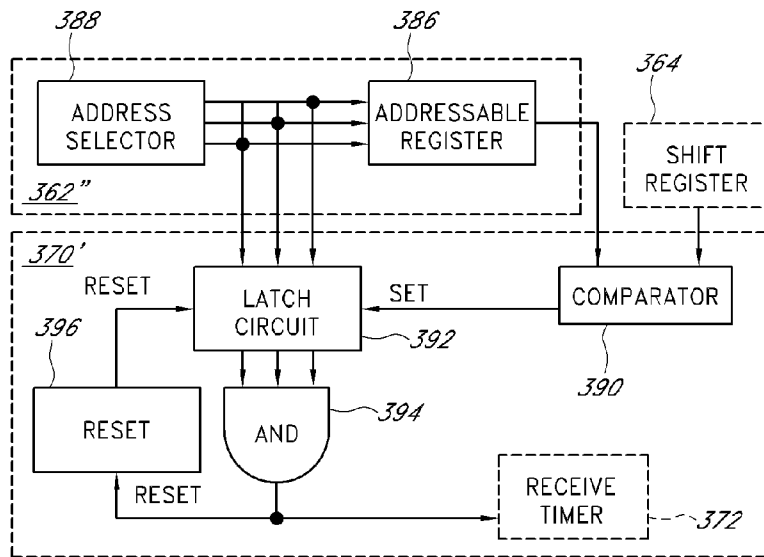

FIG. 24

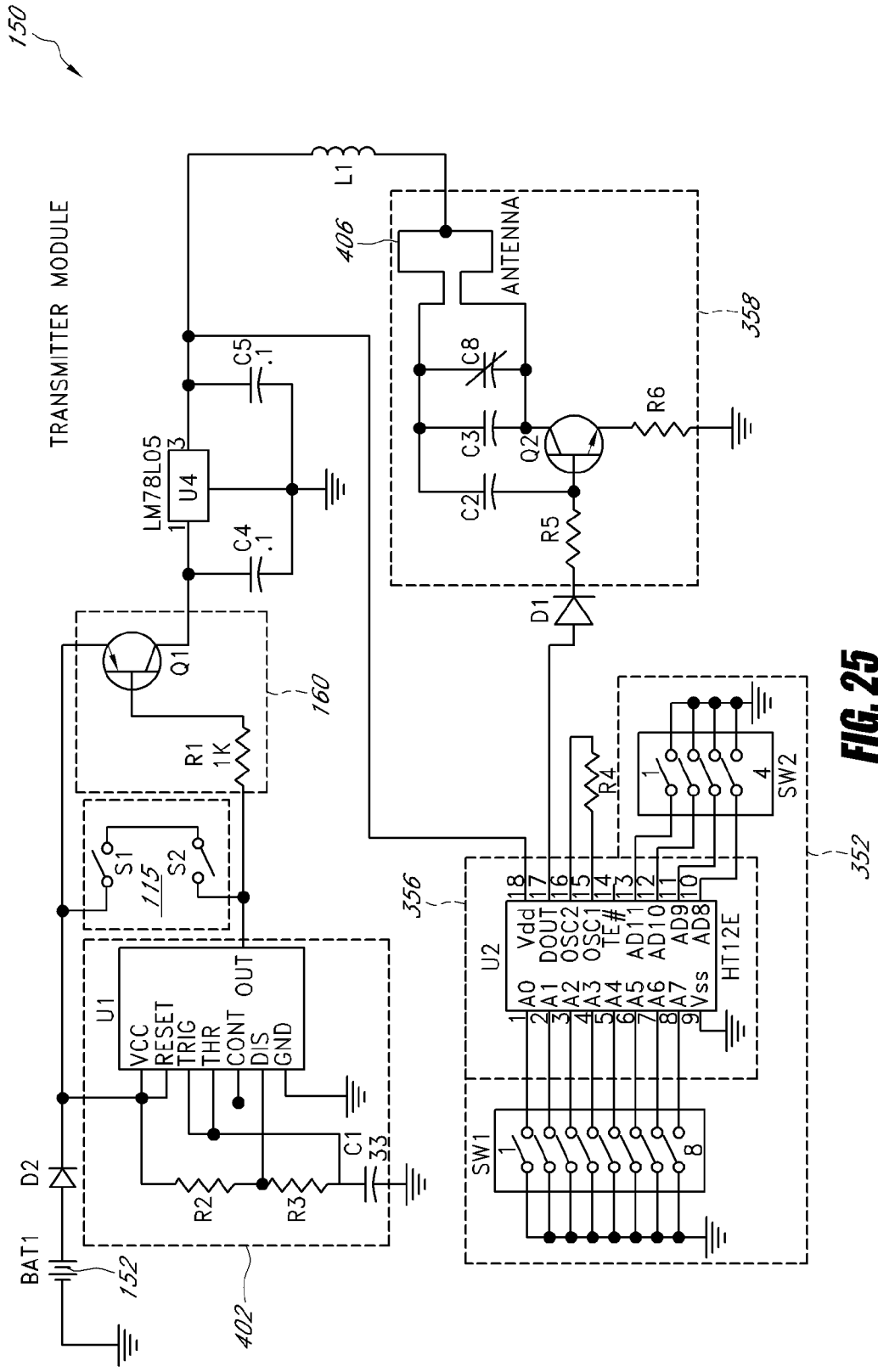

FIG. 25

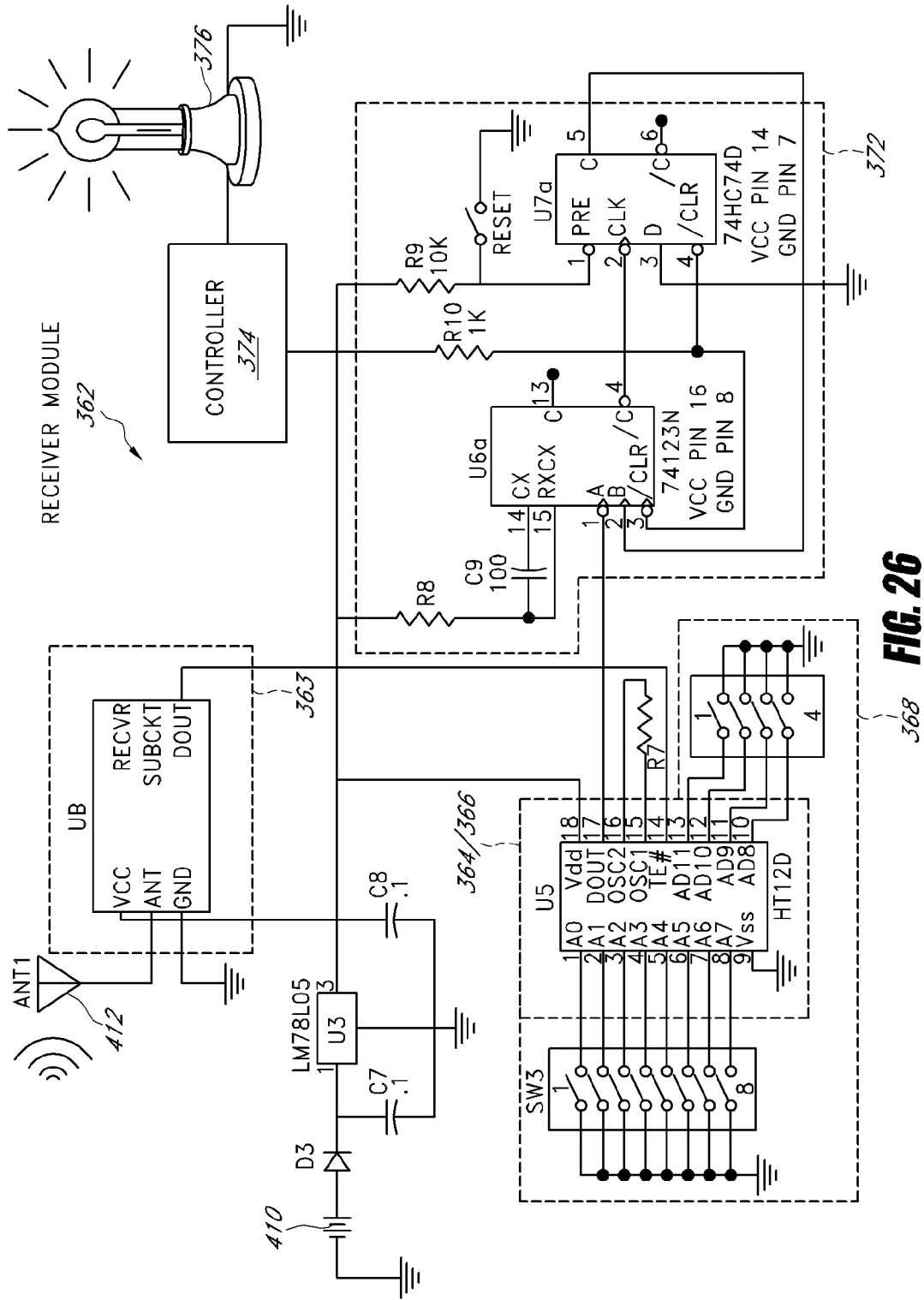

FIG. 26

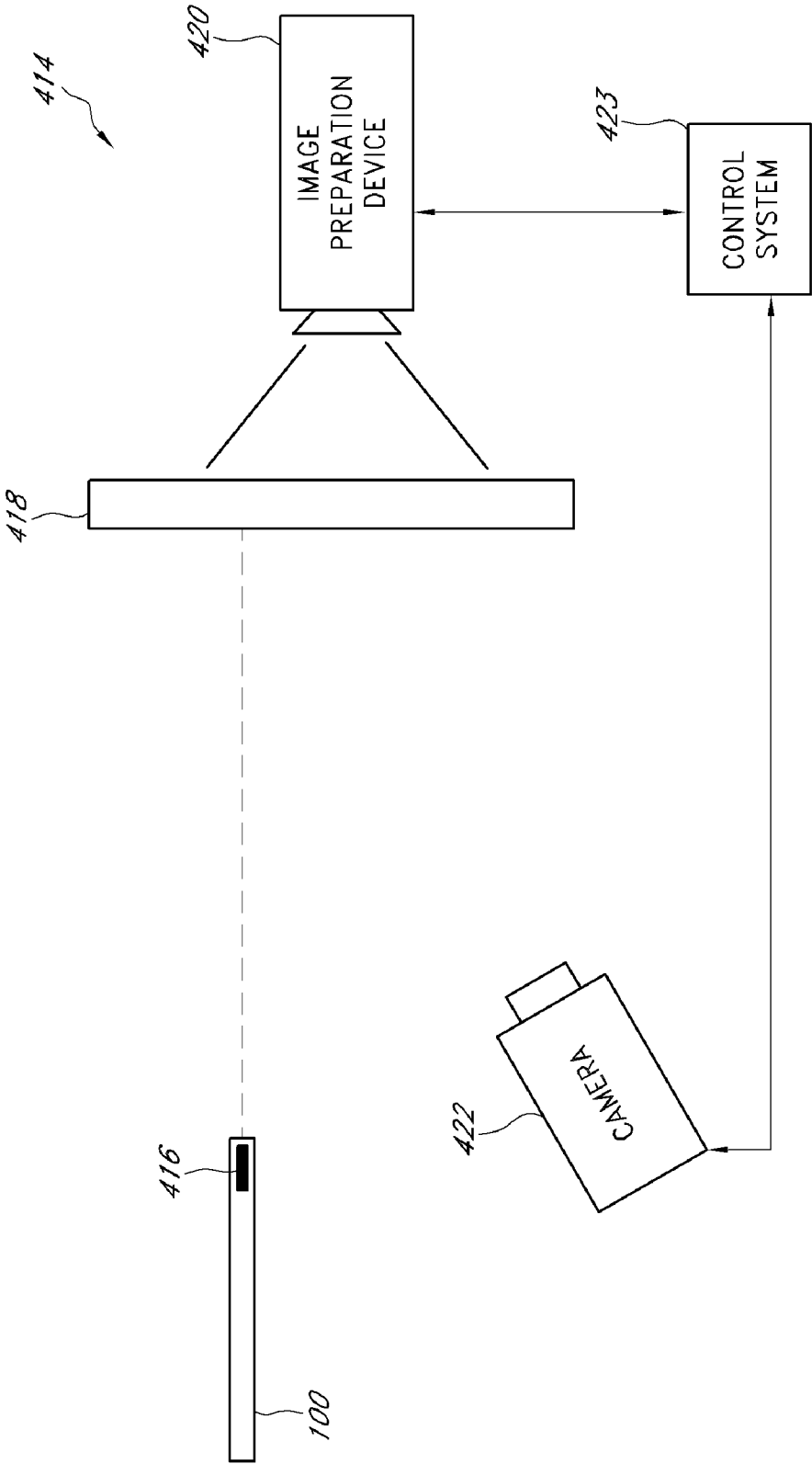

FIG. 27

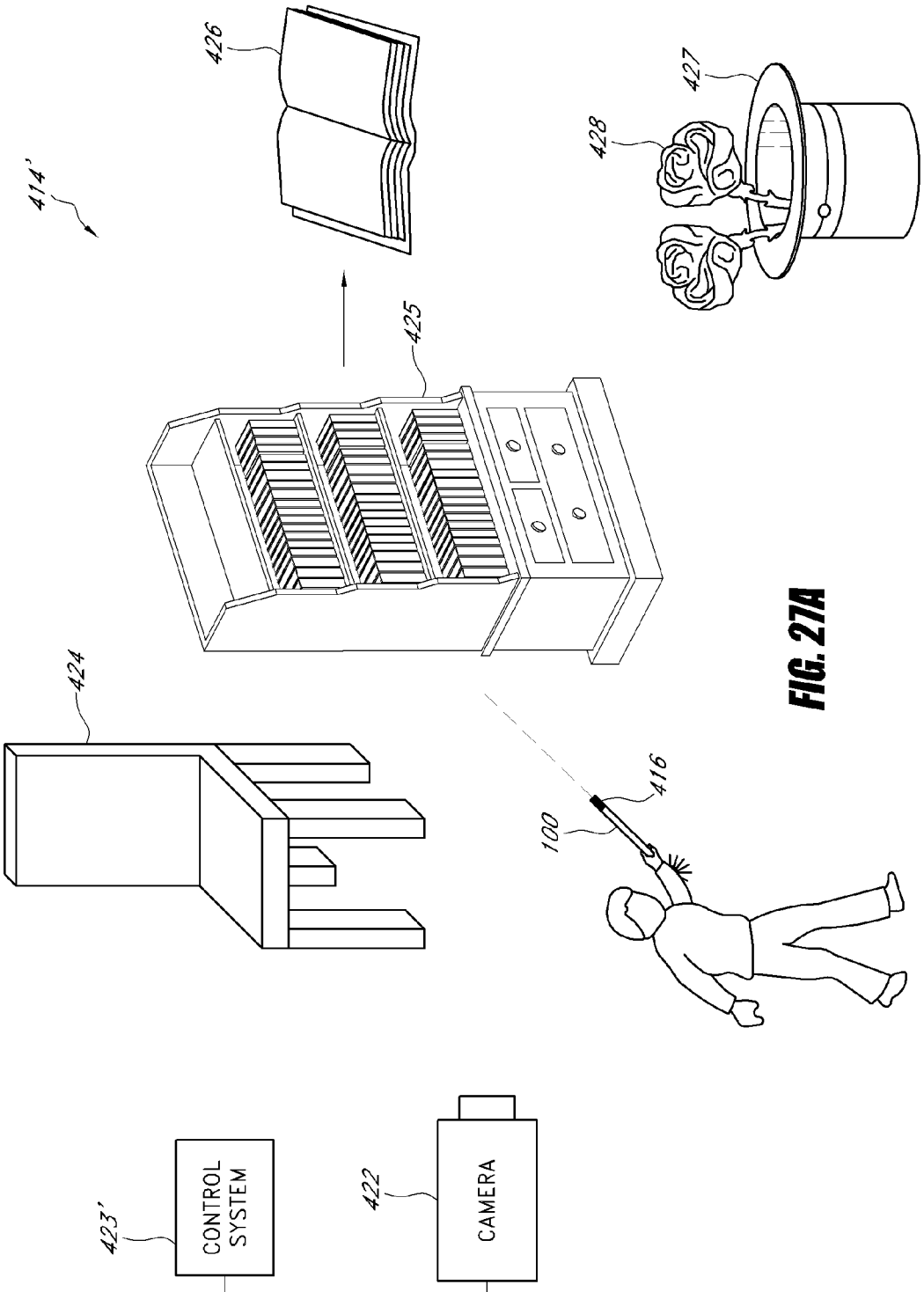

FIG. 27A

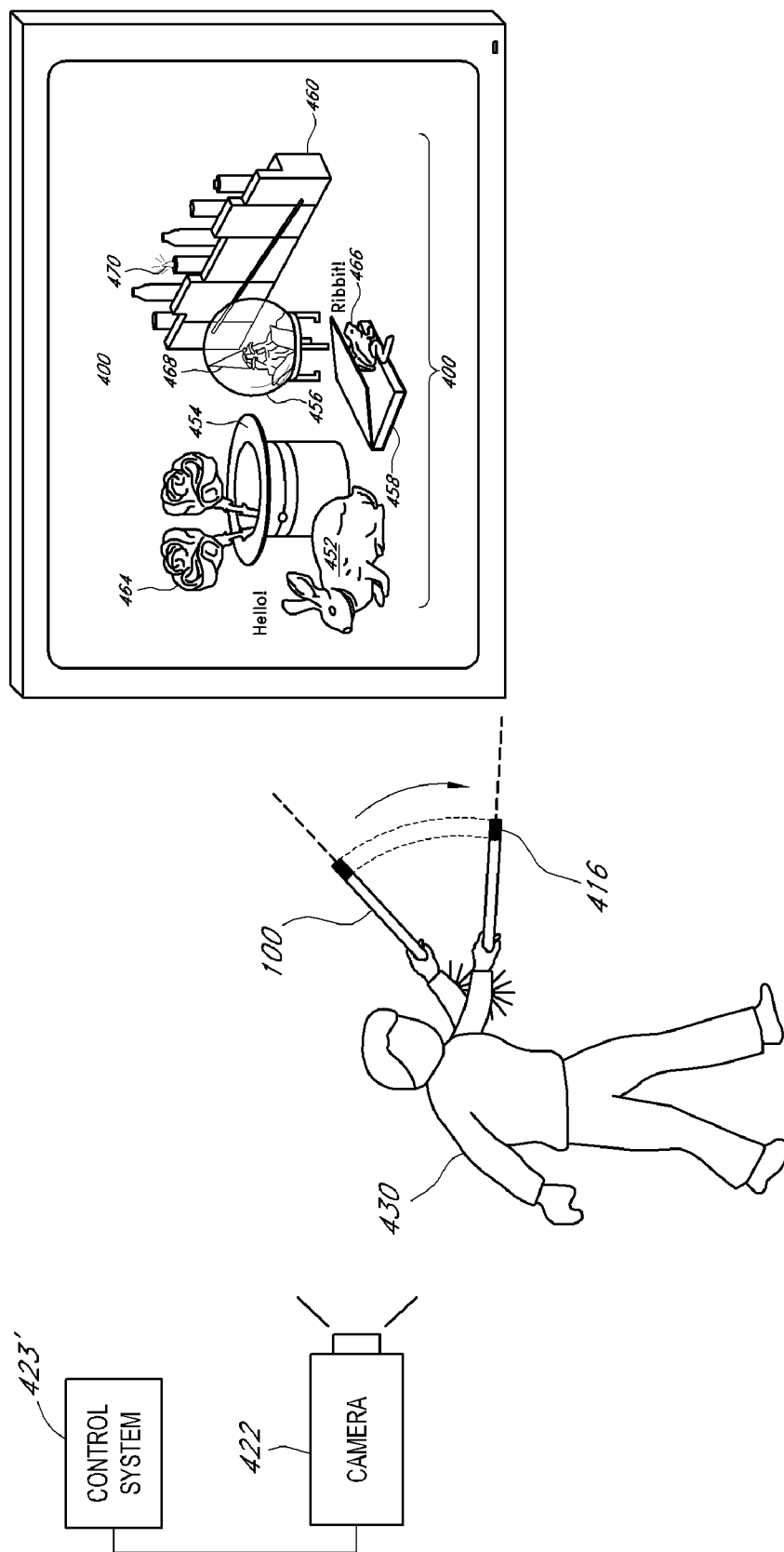

FIG. 27B

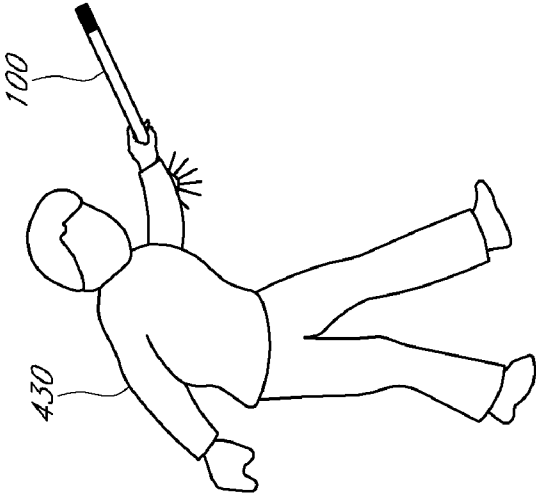
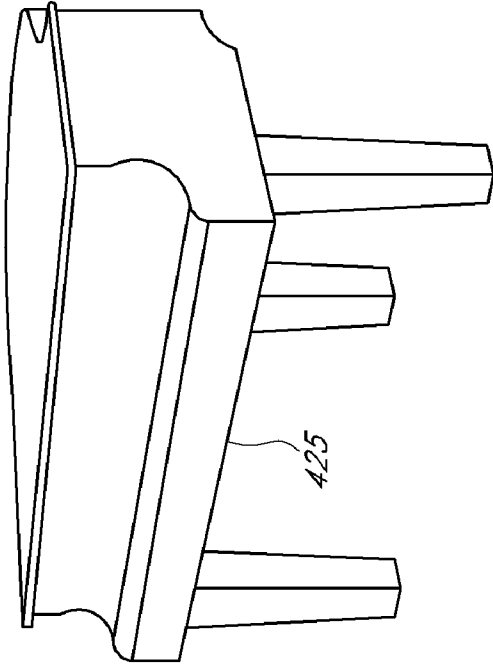
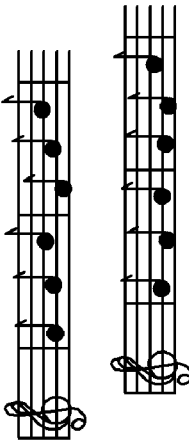

FIG. 28

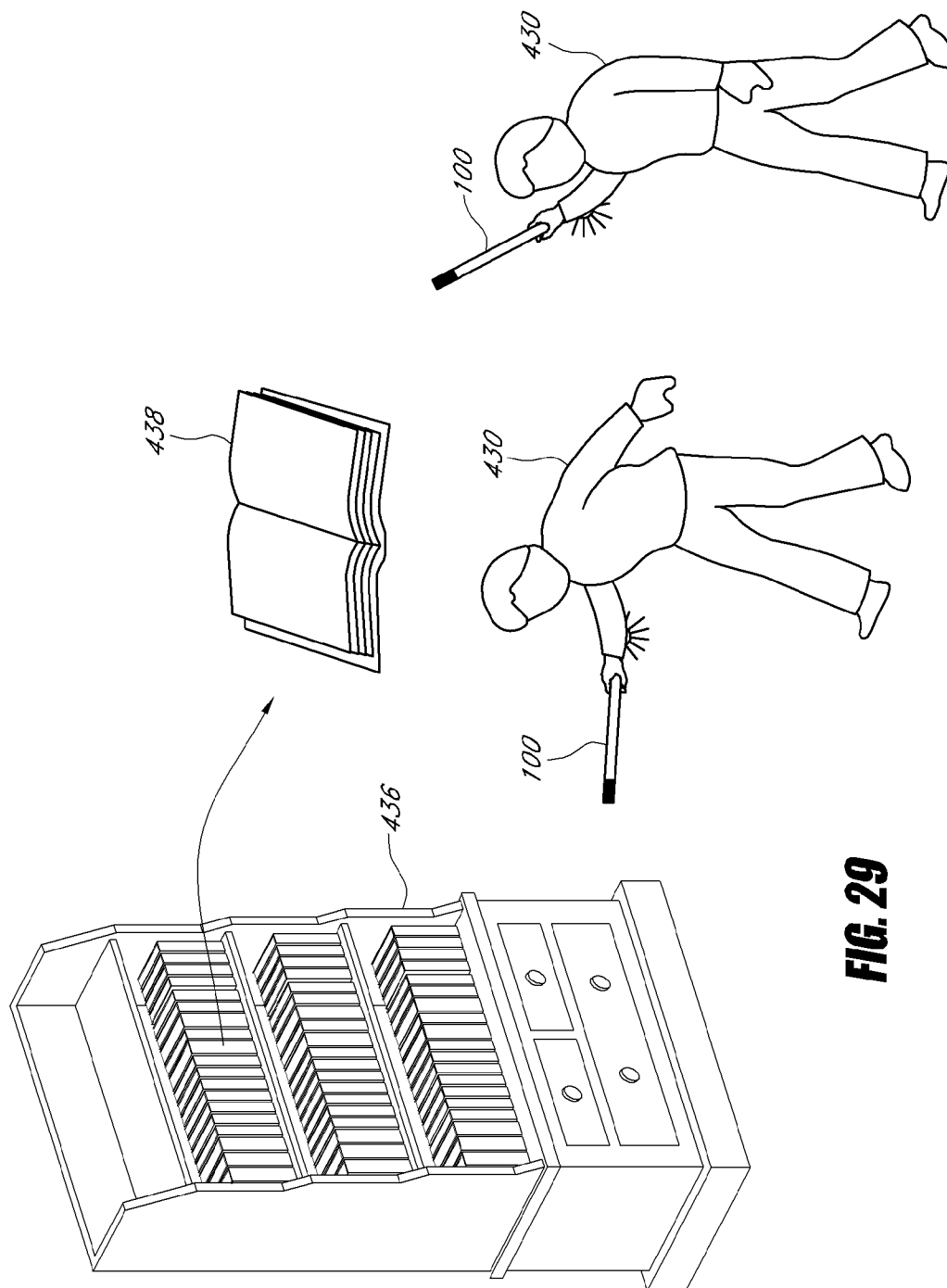

FIG. 29

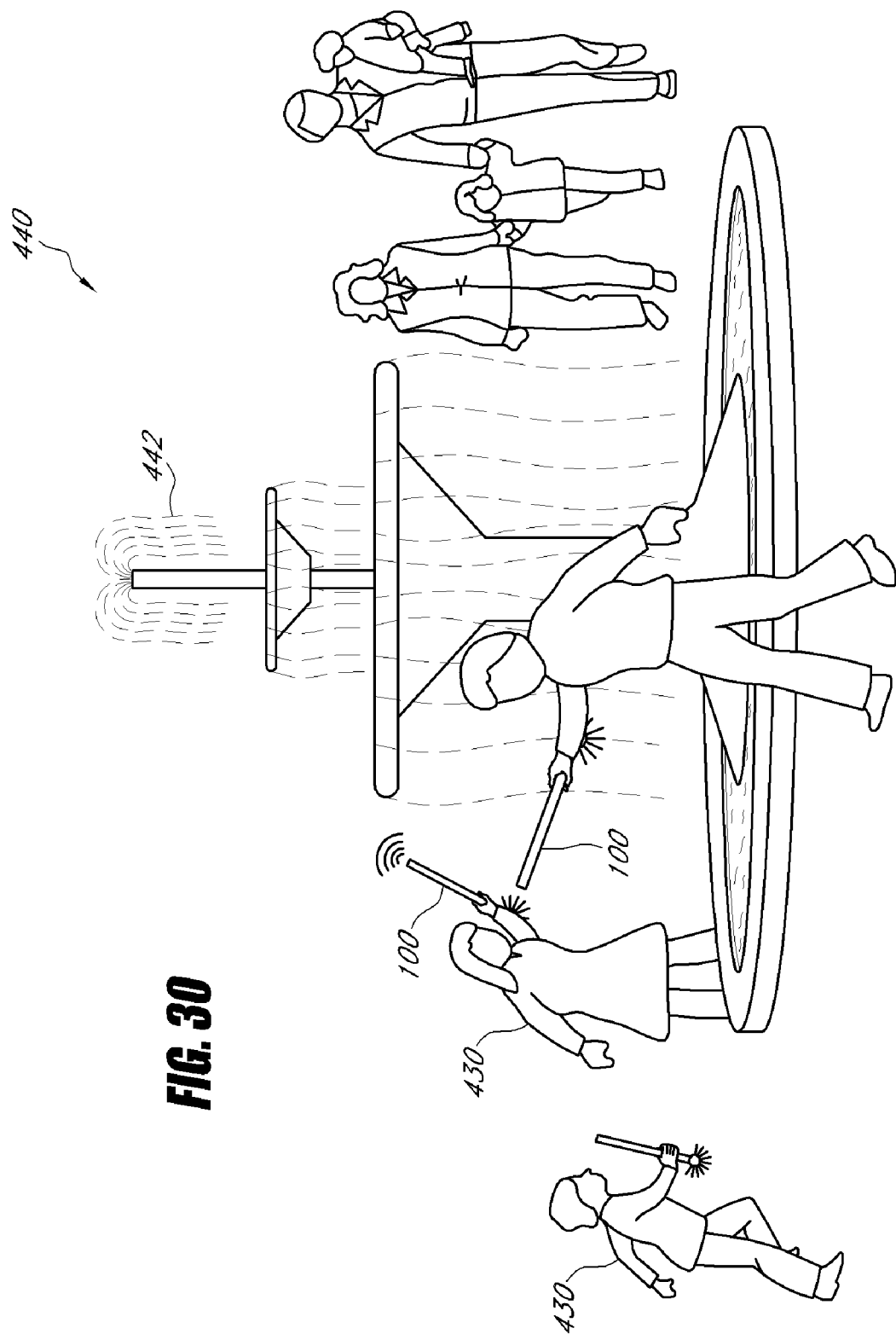

FIG. 30

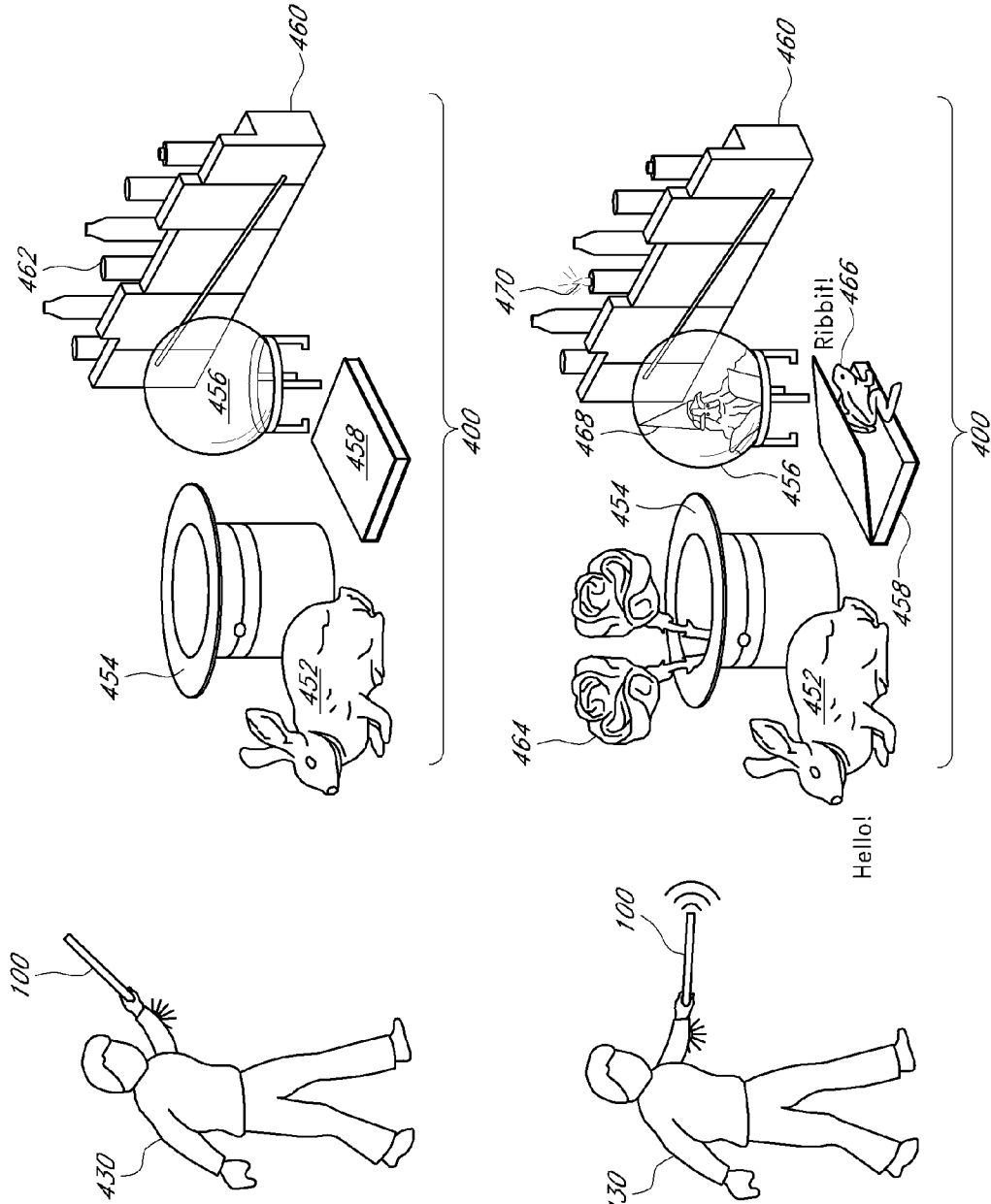

FIG. 31A

FIG. 31B

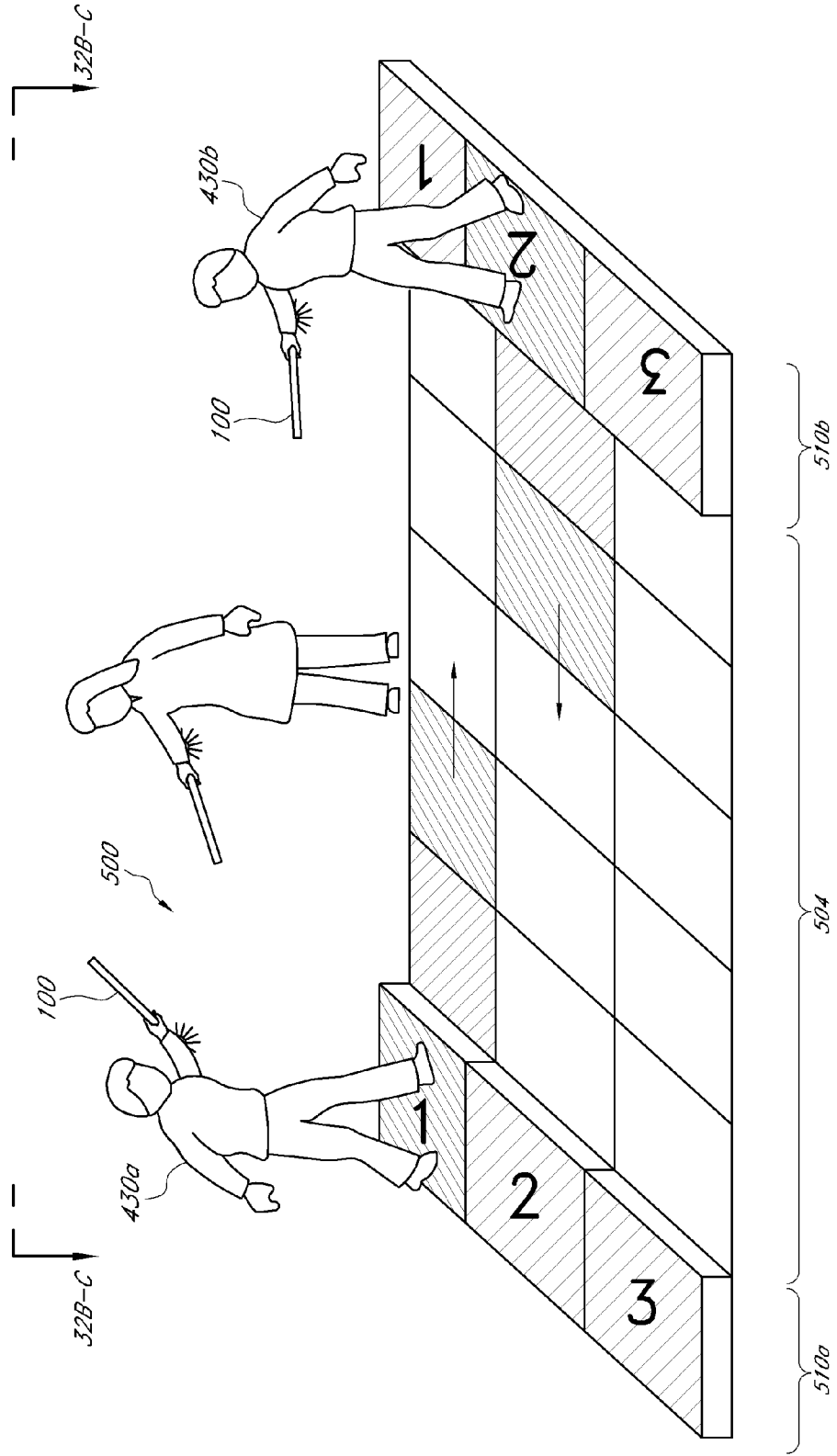
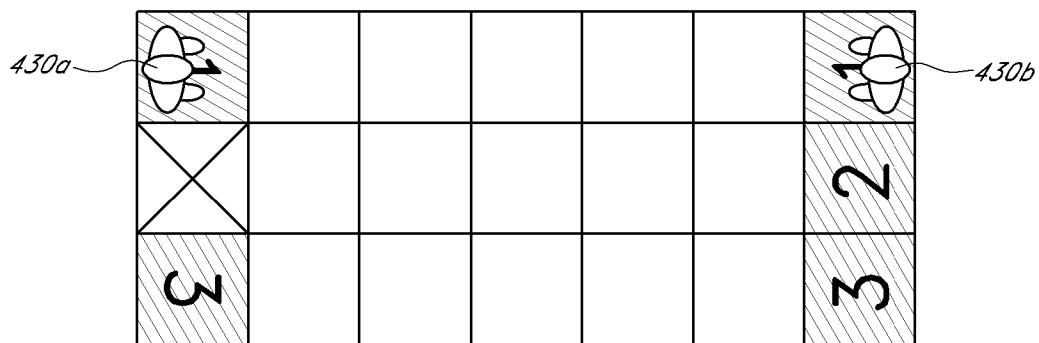
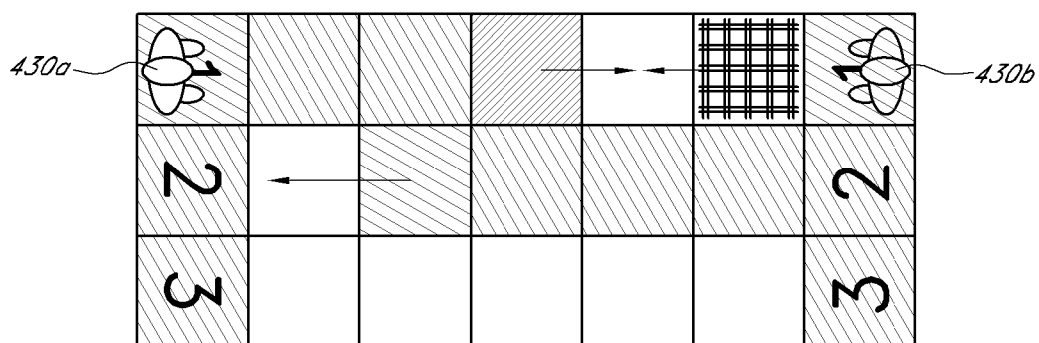
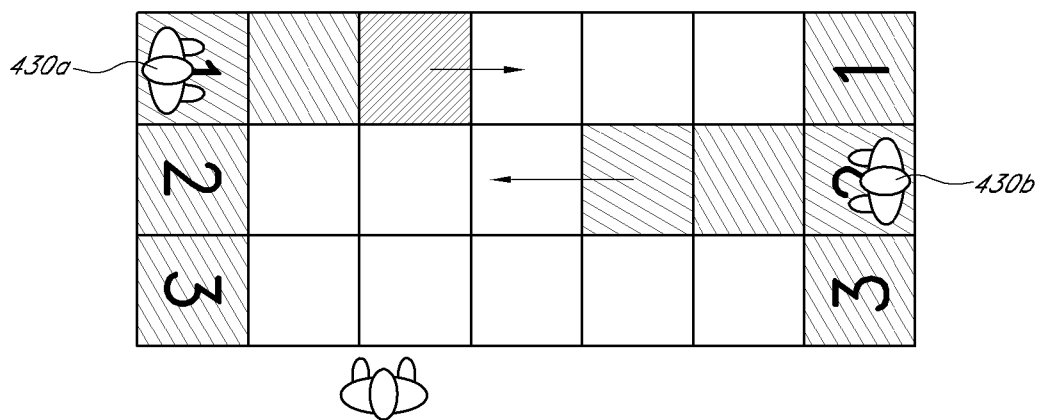
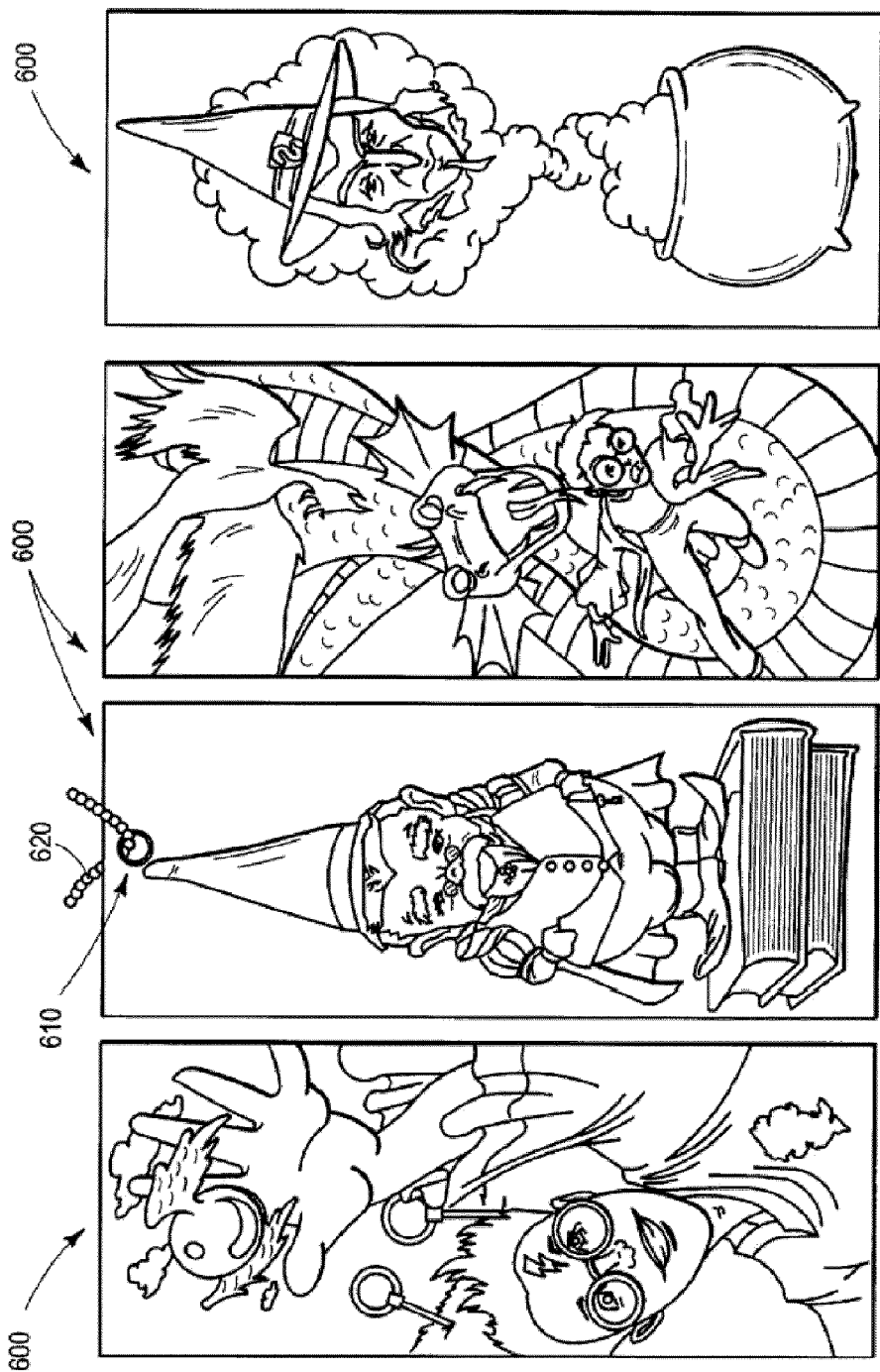

FIG. 32A





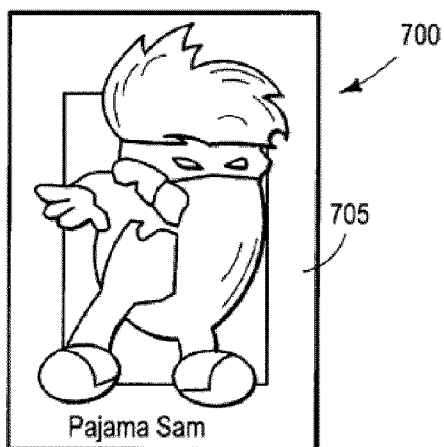

FIG. 34A

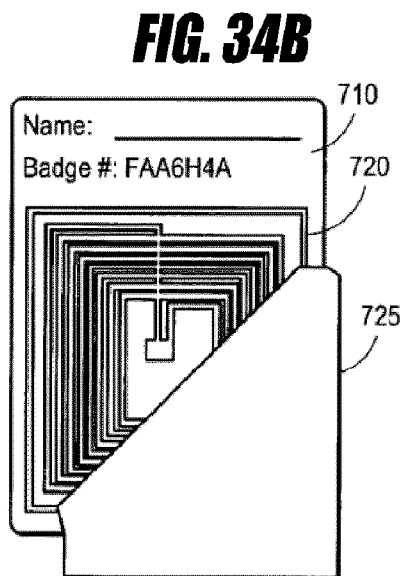

FIG. 34B



810

810

FIG. 35A

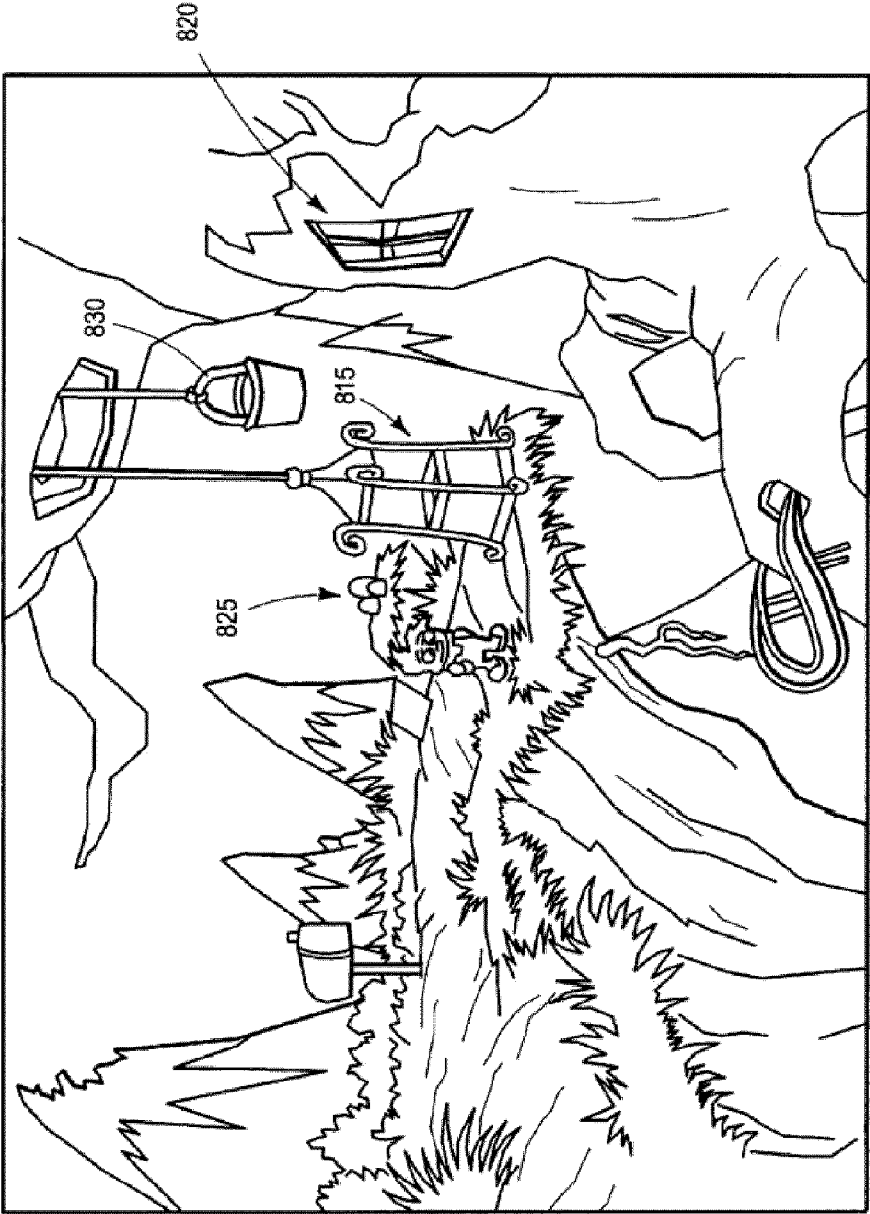

FIG. 35B

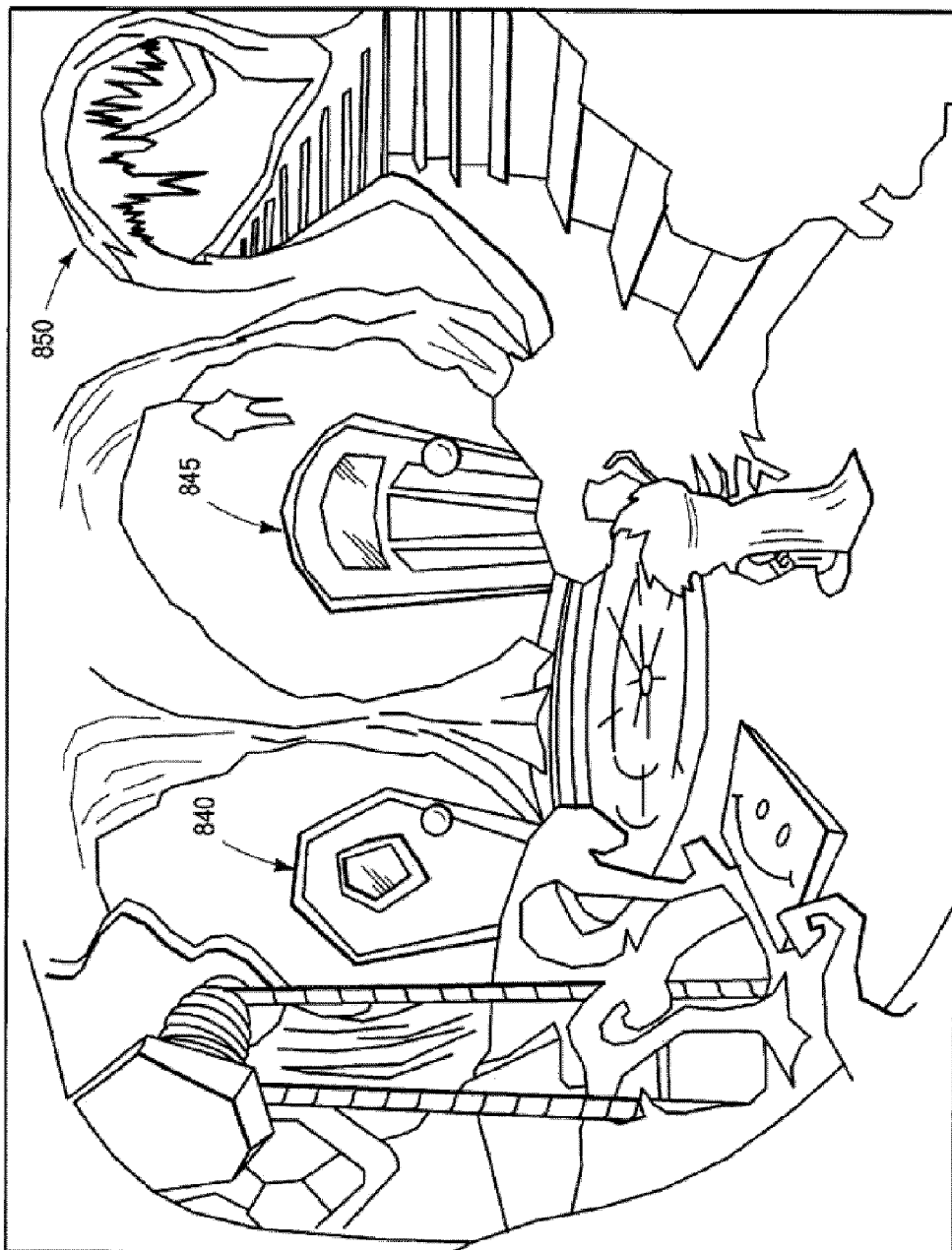

FIG. 35C



FIG. 35D



FIG. 35E

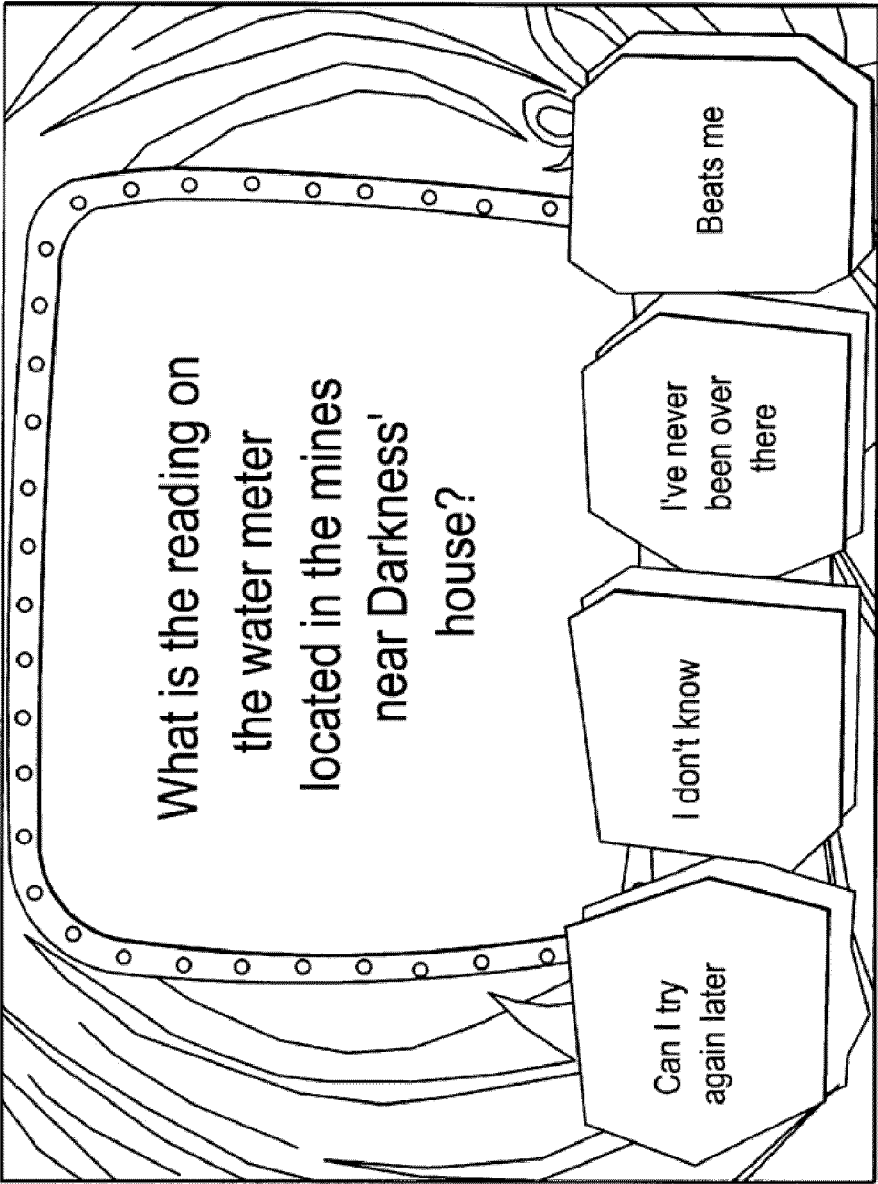

FIG. 35F

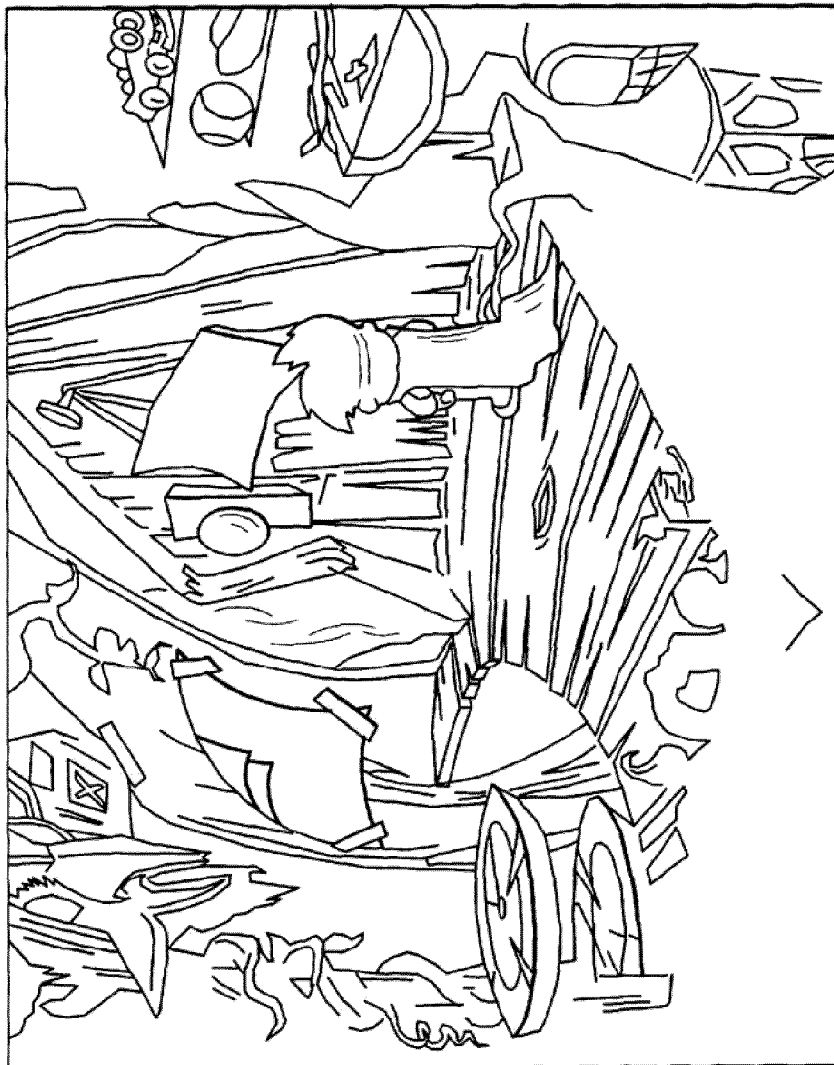

FIG. 35G

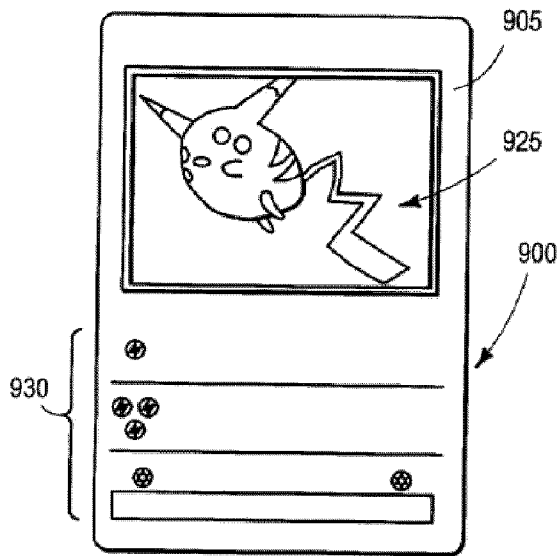

FIG. 36A

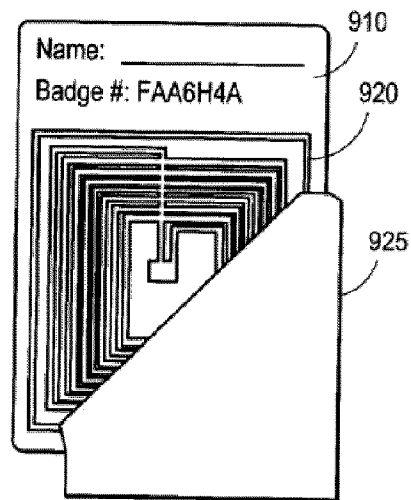

FIG. 36B

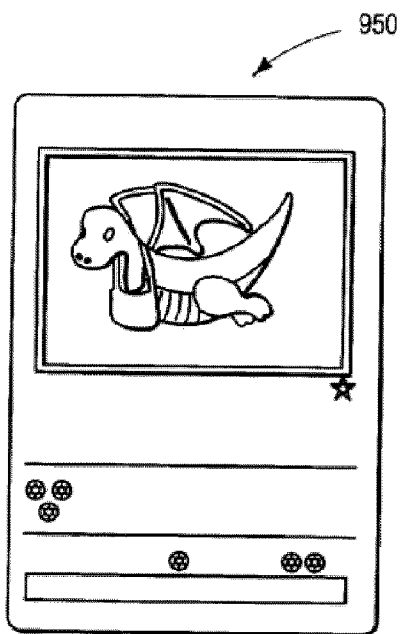

FIG. 36C



FIG. 36D

INTERACTIVE GAMING SYSTEM AND METHOD USING MOTION-SENSITIVE INPUT DEVICE

RELATED APPLICATIONS

[0001] The present application is a continuation of U.S. patent application Ser. No. 13/231,813, filed Sep. 13, 2011, which is a continuation of U.S. patent application Ser. No. 12/261,864, filed Oct. 30, 2008, which is a divisional of U.S. patent application Ser. No. 10/954,025, filed Sep. 29, 2004, now U.S. Pat. No. 7,445,550, which is a continuation-in-part of U.S. patent application Ser. No. 10/397,054, filed Mar. 25, 2003, now U.S. Pat. No. 7,500,917, which is a continuation-in-part of U.S. patent application Ser. No. 09/792,282, filed Feb. 22, 2001, now U.S. Pat. No. 6,761,637, issued Jul. 13, 2004, which claims priority under 35 U.S.C. §119(e) to U.S. Provisional Application No. 60/184,128, filed Feb. 22, 2000, each of which is hereby incorporated herein by reference in its entirety to be part of this specification.

BACKGROUND

[0002] 1. Field

[0003] The present invention generally relates to children's games and, in particular, to magic wands and interactive games and play systems utilizing wireless transponders and receivers for providing a magical interactive play experience. The present invention also relates particularly to interactive toys, games and play systems utilizing radio frequency transponders and transceivers to provide a unique interactive game play experience.

[0004] 2. Description of the Related Art

[0005] Games, toys, play structures and other similar entertainment systems are well known for providing play and interaction among children and adults. A variety of commercially available play toys and games are also known for providing valuable learning and entertainment opportunities for children, such as role playing, reading, memory stimulation, tactile coordination and the like.

[0006] Magic and wizardry are classic play themes that continue to capture imaginations and entertain new generations of children and adults like. Magic and the seemingly limitless possibilities of fun and exciting things brought to life through magic challenge children's imaginations, creativity and social interactivity.

[0007] While there are many games and toys that specifically target magic and wizardry as a central play theme, most offer only a superficially engaging play experience, particularly for older children. Very few offer a fully immersive play experience that allows participants to carry out and immerse themselves in a realistic fantasy experience of practicing, performing and mastering "real" magic. In any event, there is always demand for more exciting and entertaining games and toys that increase learning and entertainment opportunities for children and stimulate creativity and imagination.

SUMMARY

[0008] Embodiments of the present invention provide a unique play experience carried out utilizing an interactive "wand" and/or other seemingly magical actuation/tracking device. The wand or other actuation device allows play participants to electronically and "magically" interact with their

surrounding play environment(s), thereby giving play participants the realistic illusion of practicing, performing and mastering "real" magic.

[0009] Embodiments of the invention may be carried out in association with virtually any suitable play environment, play structure, play area or other area (either commercial or residential), as desired. It can also be carried out in non-physical play environments, such as television, radio, virtual reality, computer games and the like. The play environment may be simply a themed play area, or even a multi-purpose area such as a restaurant dining facility, family room, bedroom or the like. The play environment may either be real or imaginary (i.e., computer/TV generated), and either local or remote, as desired. Optionally, multiple play participants, each provided with a suitable "wand" and/or other actuation/tracking device, may play and interact together, either within or outside one or more compatible play environments, to achieve desired goals, master certain magical spells and/or produce desired seemingly magical effects within the play environment.

[0010] In accordance with one embodiment the present invention provides a toy wand or other seemingly magical object which provides a basic foundation for a complex, interactive entertainment system to create a seemingly magic interactive play experience for play participants who possess and learn to use the magical wand toy.

[0011] In accordance with another embodiment, the present invention provides an interactive play system and seemingly magical wand toy for enabling a trained user to electronically send and receive information to and from other wand toys and/or to and from various transceivers distributed throughout a play facility and/or connected to a master control system. The toy wand or other seemingly magical object is configured to use a send/receive radio frequency communications protocol which provides a basic foundation for a complex, interactive entertainment system to create a seemingly magic interactive play experience for play participants who possess and learn to use the magical wand toy.

[0012] In accordance with another embodiment the present invention provides a "magic" training facility wherein play participants can select and/or build and then learn to use a "real" magic wand. The wand allows play participants to electronically and "magically" interact with their surrounding play environment simply by pointing, touching or using their wands in a particular manner to achieve desired goals or produce desired effects within the play environment. Various wireless receivers or actuators are distributed throughout the play facility to facilitate such interaction and to facilitate full immersion in the fantasy of practicing, performing and mastering "real" magic.

[0013] In accordance with another embodiment the present invention provides a wand actuator device for actuating various interactive play effects within a compatible play environment. The wand comprises an elongated hollow pipe or tube having a proximal end or handle portion and a distal end or transmitting portion. An internal cavity may be provided to receive one or more batteries to power optional lighting, laser or sound effects and/or to power long-range transmissions such as via an infrared LED transmitter device or RF transmitter device. The distal end of the wand may be fitted with an RFID (radio frequency identification device) transponder that is operable to provide relatively short-range RF communications (<60 cm) with one or more receivers or transceivers distributed throughout a play environment. A magnetic tip

may also be provided for actuating various effects via one or more magnetically operated reed switches. The handle portion of the wand may be fitted with an ornamental knob that is selected by play participants from an available assortment. Knobs may be fitted with an optional rotary switch that may be selectably rotated to indicate different spells, commands or combinations of spells and commands for activating or controlling various associated special effects.

[0014] In accordance with another embodiment the present invention provides a wand having an RFID transponder or tag. The transponder contains certain electronics comprising a radio frequency tag pre-programmed with a unique person identifier number (“UPIN”). The UPIN may be used to identify and track individual play participants and/or wands within the play facility. Optionally, each tag may also include a unique group identifier number (“UGIN”), which may be used to match a defined group of individuals having a predetermined relationship. The RFID transponder or other identifying device is preferably used to store certain information identifying each play participant and/or describing certain powers or abilities possessed by an imaginary role-play character. Players advance in a magic adventure game by finding clues, casting spells and solving various puzzles presented. Players may also gain (or lose) certain attributes, such as magic skills, magic strength, fighting ability, various spell-casting abilities, combinations of the same or the like. All of this information is preferably stored on the RFID transponder and/or an associated database indexed by UPIN so that the character attributes may be easily and conveniently transported to other similarly-equipped play facilities, computer games, video games, home game consoles, hand-held game units, and the like. In this manner, an imaginary role-play character is created and stored on a transponder device that is able to seamlessly transcend from one play environment to the next.

[0015] In accordance with another embodiment, the present invention provides an RFID card or badge intended to be affixed or adhered to the front of a shirt or blouse worn by a play participant while visiting an RF equipped play facility. The badge comprises a paper, cardboard or plastic substrate having a front side and a back side. The front side may be imprinted with graphics, photos, or any other information desired. The front side may include any number of other designs or information pertinent to its application. The obverse side of the badge contains certain electronics comprising a radio frequency tag pre-programmed with a unique person identifier number (“UPIN”). The UPIN may be used to identify and track individual play participants within the play facility. Optionally, each tag may also include a unique group identifier number (“UGIN”) which may be used to match a defined group of individuals having a predetermined relationship.

[0016] In accordance with another embodiment, the present invention provides an electronic role-play game utilizing specially configured electronically readable character cards. Each card is configured with an RFID or a magnetic “swipe” strip or the like, that may be used to store certain information describing the powers or abilities of an imaginary role-play character that the card represents. As each play participant uses his or her favorite character card in various play facilities the character represented by the card gains (or loses) certain attributes, such as magic skill level, magic strength, flight ability, various spell-casting abilities, etc. All of this information is preferably stored on the card so that the

character attributes may be easily and conveniently transported to other similarly-equipped play facilities, computer games, video games, home game consoles, hand-held game units, and the like. In this manner, an imaginary role-play character is created and stored on a card that is able to seamlessly transcend from one play medium to the next.

[0017] In accordance with another embodiment the present invention provides a trading card game wherein a plurality of cards depicting various real or imaginary persons, characters and/or objects are provided and wherein each card has recorded or stored thereon in an electronically readable format certain selected information pertaining to the particular person, character or object, such as performance statistics, traits/powers, or special abilities. The information is preferably stored on an RFID tracking tag associated with each card and which can be read electronically and wirelessly over a predetermined range preferably greater than about 1 cm when placed in the proximity of a suitably configured RF reader. Optionally, the RFID tag may be read/write capable such that it the information stored thereon may be changed or updated in any manner desired. Alternatively, a magnetic strip, bar code or similar information storage means may be used to store relevant information on the card.

[0018] For purposes of summarizing the invention and the advantages achieved over the prior art, certain objects and advantages of the invention have been described herein above. Of course, it is to be understood that not necessarily all such objects or advantages may be achieved in accordance with any particular embodiment of the invention. Thus, for example, those skilled in the art will recognize that the invention may be embodied or carried out in a manner that achieves or optimizes one advantage or group of advantages as taught herein without necessarily achieving other objects or advantages as may be taught or suggested herein.

[0019] All of these embodiments are intended to be within the scope of the invention herein disclosed. These and other embodiments of the present invention will become readily apparent to those skilled in the art from the following detailed description of the preferred embodiments having reference to the attached figures, the invention not being limited to any particular preferred embodiment(s) disclosed.

BRIEF DESCRIPTION OF THE DRAWINGS

[0020] Having thus summarized the general nature of the invention and its essential features and advantages, certain preferred embodiments and modifications thereof will become apparent to those skilled in the art from the detailed description herein having reference to the figures that follow, of which:

[0021] FIG. 1 is a schematic illustration of one embodiment of an interactive wand toy having features and advantages in accordance with the present invention;

[0022] FIGS. 2A and 2B are schematic illustrations of a mercury tilt switch for use in accordance with one embodiment of the present invention and being shown in the OFF and ON conditions, respectively;

[0023] FIGS. 3A and 3B are schematic illustrations of a micro-ball tilt switch (normally closed configuration) for use in accordance with one embodiment of the present invention and being shown in the ON and OFF conditions, respectively;

[0024] FIGS. 4A and 4B are schematic illustrations of a micro-ball tilt switch (normally open configuration) for use in accordance with one embodiment of the present invention and being shown in the ON and OFF conditions, respectively;

[0025] FIGS. 5A and 5B are schematic illustrations of the interactive wand toy of FIG. 1 in upward and downward orientations, respectively;

[0026] FIG. 6 is a partial perspective view of a user waving the interactive wand toy of FIG. 1 in such a way to produce actuation thereof;

[0027] FIG. 7 is a schematic illustration of an alternative embodiment of an interactive wand toy including an optional RF/IR module and having features and advantages in accordance with the present invention;

[0028] FIG. 8 is a schematic illustration of a further alternative embodiment of an interactive wand toy including an optional magnetic inductance energy source having features and advantages in accordance with the present invention;

[0029] FIG. 9 is a schematic illustration of a further alternative embodiment of an interactive wand toy including an optional piezo generator energy source having features and advantages in accordance with the present invention;

[0030] FIG. 10 is a schematic illustration of a piezo armature for use in a piezo generator having features and advantages in accordance with the present invention;

[0031] FIG. 11 is a schematic circuit diagram of the piezo generator and power supply of FIG. 9 having features and advantages in accordance with the present invention;

[0032] FIG. 12 is a schematic illustration of a further alternative embodiment of an interactive wand toy including an RF/IR module and optional RFID transponder having features and advantages in accordance with the present invention;

[0033] FIG. 13 is a schematic illustration of a further alternative embodiment of an interactive wand toy including an RF/IR module and optional RFID transponder having features and advantages in accordance with the present invention;

[0034] FIG. 14A is a schematic illustration of a further alternative embodiment of an interactive wand toy including optional orientation sensors having features and advantages in accordance with the present invention;

[0035] FIG. 14B is a detail transverse cross-sectional view of the handle portion of the interactive wand toy of FIG. 14A, illustrating the preferred placement and orientation of the optional orientation sensors and having features and advantages in accordance with the present invention;

[0036] FIG. 15A is a schematic illustration of a further alternative embodiment of an interactive wand toy including optional rotary switch having features and advantages in accordance with the present invention;

[0037] FIG. 15B is a detail transverse cross-sectional view of the handle portion of the interactive wand toy of FIG. 15A illustrating one preferred embodiment of a rotary switch having features and advantages in accordance with the present invention;

[0038] FIG. 15C is a partial perspective view of a user rotating the knob of the interactive wand toy of FIG. 15A in such a way to produce a desired wand operation or effect;

[0039] FIG. 15D is a detail view of the handle portion and rotatable knob of the interactive wand toy of FIGS. 15A and 15B;

[0040] FIG. 16A is a schematic illustration of a further alternative embodiment of an interactive wand toy including optional touch sensor elements having features and advantages in accordance with the present invention;

[0041] FIG. 16B is a detail view of one embodiment of a touch sensor element of FIG. 16A having features and advantages in accordance with the present invention;

[0042] FIG. 16C is a partial perspective view of a user operating the touch-sensor-enabled interactive wand toy of FIG. 15A in such a way to produce a desired wand operation of effect;

[0043] FIG. 16D is a detail view of the handle portion and touch sensor contact elements of the interactive wand toy of FIGS. 16A and 16C;

[0044] FIGS. 17A-17B are time-sequenced illustrations of one embodiment of a wand-actuated effect using the interactive wand toy of FIG. 16 with optional magnetic tip and a magnetic reed switch having features and advantages in accordance with the present invention;

[0045] FIG. 17C is an alternative embodiment of a wand-actuated effect using the interactive wand toy of FIG. 16 with optional magnetic tip, a magnetic reed switch and an optional RF/IR receiver having features and advantages in accordance with the present invention;

[0046] FIGS. 18A and 18B are schematic illustrations showing one preferred method for fabricating, assembling and finishing an interactive wand toy having features and advantages in accordance with the present invention;

[0047] FIGS. 19A-19P are schematic illustrations showing various possible constructions, configurations and finishes of interactive wand toys having features and advantages in accordance with the present invention;

[0048] FIGS. 20A and 20B are schematic illustrations showing two alternative preferred embodiments of an RFID-enabled wand toy having features and advantages in accordance with the present invention;

[0049] FIGS. 20C and 20D are front and back views, respectively, of a preferred embodiment of an RFID-enabled trading card having features and advantages in accordance with the present invention;

[0050] FIGS. 20E and 20F are front and back views, respectively, of a preferred embodiment of an RFID-enabled key chain trinket having features and advantages in accordance with the present invention;

[0051] FIG. 21A is a partial cross-section detail view of the distal end of the interactive wand toy of FIG. 1, illustrating the provision of an RFID transponder device therein;

[0052] FIG. 21B is a schematic illustration of an RFID read/write unit for use with the interactive wand toy of FIG. 1 having features and advantages in accordance with the present invention;

[0053] FIG. 21C is a simplified circuit schematic of the RFID read/write unit of FIG. 21B having features and advantages in accordance with the present invention;

[0054] FIG. 22A is a simplified schematic block diagram of an RF transmitter module adapted for use in accordance with one preferred embodiment of the present invention;

[0055] FIG. 22B is a simplified schematic block diagram of an IR transmitter module adapted for use in accordance with one preferred embodiment of the present invention;

[0056] FIG. 23A is a simplified schematic block diagram of an RF receiver module and controller adapted for use in accordance with one preferred embodiment of the present invention;

[0057] FIG. 23B is a simplified schematic block diagram of an RF receiver module and controller adapted for use in accordance with one preferred embodiment of the present invention;

[0058] FIG. 24 is a simplified schematic diagram of an alternative embodiment of a portion of the RF receiver module of FIG. 23A adapted for use in accordance with one preferred embodiment of the present invention;

[0059] FIG. 25 is a detailed electrical circuit schematic of the RF transmitter module of FIG. 22A adapted for use in accordance with one preferred embodiment of the present invention;

[0060] FIG. 26 is a detailed electrical circuit schematic of the RF receiver module of FIG. 23A adapted for use in accordance with one preferred embodiment of the present invention;

[0061] FIG. 27 is a simplified illustration of an interactive play system usable with light-activation in accordance with one preferred embodiment of the present invention;

[0062] FIG. 27A is a simplified illustration of another embodiment of an interactive play system usable with light-activation;

[0063] FIG. 27B is a simplified illustration of another embodiment of an interactive play system usable with light-activation;

[0064] FIG. 28 is a perspective illustration of one preferred embodiment of a wand-actuated play effect comprising a player piano controlled at least in part by the output of an RF receiver and/or magnetic reed switch having features and advantages in accordance with the present invention;

[0065] FIG. 29 is a perspective illustration of another preferred embodiment of a wand-actuated play effect comprising bookshelves with simulated levitating books controlled at least in part by the output of an RF receiver and/or magnetic reed switch having features and advantages in accordance with the present invention;

[0066] FIG. 30 is a perspective illustration of another preferred embodiment of a wand-actuated play effect comprising a water fountain effect controlled at least in part by the output of an RF receiver and/or magnetic reed switch having features and advantages in accordance with the present invention;

[0067] FIGS. 31A and 31B are time-sequenced perspective views of a magic training center comprising various wand-actuated play effects controlled at least in part by the output of one or more RF receivers and/or magnetic reed switches having features and advantages in accordance with the present invention;

[0068] FIG. 32A is a perspective illustration of one preferred embodiment of a wand-actuated game comprising a grid of lighted squares that are controlled at least in part by one or more RF receivers and/or magnetic reed switches having features and advantages in accordance with the present invention;

[0069] FIGS. 32B-32D are time-sequenced top plan views of the wand-actuated game of FIG. 32A, illustrating the preferred operation thereof and having features and advantages in accordance with the present invention;

[0070] FIGS. 33A-33D are front views of various role-play character cards for use within an interactive play structure;

[0071] FIGS. 34A and 34B are front and rear views, respectively, of an alternative embodiment of a role-play character card for use with a specially configured interactive game and/or game play facility having features and advantages in accordance with the present invention;

[0072] FIGS. 35A-35G are various illustrations of a role-play adventure game configured to be utilized with the role-

play character card of FIGS. 34A and 34B and having features and advantages in accordance with the present invention;

[0073] FIGS. 36A and 36B are front and rear views, respectively, of a trading or playing card having features and advantages in accordance with the present invention; and

[0074] FIGS. 36C and 36D are front views of several alternative embodiments of trading or playing cards having features and advantages in accordance with the present invention.

DETAILED DESCRIPTION

[0075] For convenience of description and for better clarity and understanding of the invention similar elements to those previously described may be identified with similar or identical reference numerals. However, not all such elements in all embodiments are necessarily identical as there may be differences that become clear when read and understood in the context of each particular disclosed preferred embodiment.

[0076] Interactive Wand

[0077] A wand is provided that allows play participants to electronically and “magically” interact with their surrounding play environment simply by pointing or using their wands in a particular manner to achieve desired goals or produce desired effects within the play environment. Use of the wand may be as simple as touching it to a particular surface or “magical” item within a suitably configured play environment or it may be as complex as shaking or twisting the wand a predetermined number of times in a particular manner and/or pointing it accurately at a certain target desired to be “magically” transformed or otherwise affected.

[0078] For example, various wand-compatible receivers may be distributed throughout a play facility that will allow wand users to activate various associated play effects and/or to play a game using the wand. As play participants play and interact within each play environment they learn more about the “magical” powers possessed by the wand and become more adept at using the wand within various game contexts to achieve desired goals or desired play effects. Optionally, play participants may collect points or earn additional magic levels or ranks for each play effect or task they successfully achieve. In this manner, play participants may compete with one another to see who can score more points and/or achieve the highest magic level.

[0079] FIG. 1 illustrates the basic construction of one preferred embodiment of an interactive “magic” wand toy 100 having features and advantages in accordance with the present invention. While a magic wand is specifically contemplated and described herein as the most preferred embodiment of the invention, those skilled in the art will readily appreciate from the disclosure herein that the invention is not limited to wands, but may be carried out using any number or variety of other objects and toys for which it may be desirable to imbue special “magic” powers or other functionalities described herein. Other suitable magical objects and toys may include, for example and without limitation, ordinary sticks, tree branches, flowers, swords, staffs, scepters, whips, paddles, nunchuks, cricket bats, baseball bats, various sporting balls, brooms, feather dusters, paint brushes, wooden spoons, chop sticks, pens, pencils, crayons, umbrellas, walking canes, candy canes, candle sticks, candles, tapers, musical instruments (e.g., flutes, recorders, drum sticks), books, diaries, flashlights, telescopes, kaleidoscopes, laser pointers, ropes, tassels, gloves, coats, hats, shoes and other clothing items, fishing rods and simulated fishing rods, dolls, action

figures, stuffed animals, rings, bracelets necklaces and other jewelry items, key chain trinkets, lighters, rocks, crystals, crystal balls, prisms, and various simulated play objects such as apples, bananas, carrots, celery and other fruits/vegetables. However, magic wands are particularly preferred because they are highly versatile, can transcend a wide variety of different play themes and play environments, and wands can be customized and personalized in their fabrication, assembly and finish as will be described herein in more detail.

[0080] As illustrated in FIG. 1, the wand 100 essentially comprises an elongated hollow pipe or tube 110 having a proximal end 112 and a distal end 114. An internal cavity 116 is preferably provided to receive and safely house various circuitry for activating and operating the wand and various wand-controlled effects (described later). Batteries, optional lighting, laser or sound effects and/or the like may also be provided and housed within cavity 116, if desired, as will be described in more detail later. An optional button may also be provided, if desired, to enable particular desired functions, such as sound or lighting effects or longer-range transmissions. While a hollow metal or plastic tube 110 is preferred, it will be appreciated that virtually any other mechanical structure or housing may be used to support and contain the various components and parts described herein, including integrally molded or encapsulated containment structures such as epoxy resins and the like. If a metal tube is selected, care must be taken to ensure that it does not unduly interfere with any of the magnetic, RFID or RF/IR devices described herein. Thus, for example, any RF antennas should preferably be mounted near or adjacent an end opening and/or other opening of the tube 110 to ensure adequate operating range and desired directionality.

[0081] The proximal end 112 of tube 110 is preferably adapted to secure the tube 110 to an optional handle 120. The handle 120 may further include securement means, such as threaded stud 121, snap latches, mating magnets or the like, for receiving and securing an optional decorative knob 123. For example, knobs 123 may be purchased, selected and/or earned by play participants as they advance in a game and/or when they play different games. The distal end 114 of the wand is preferably fitted with an RFID (radio frequency identification) transponder or tag 118 that is operable to provide relatively short-range RF communications (less than about 200 cm) using one or more RFID reader units or reader/writer units (sometimes referred to herein as "receivers" or "transceivers," respectively), described in more detail later. The transponder 118 contains certain electronics comprising a radio frequency tag pre-programmed with a unique person identifier number ("UPIN"). The UPIN may be used to identify and track individual wands and/or play participants. Optionally, each tag may also include a unique group identifier number ("UGIN") which may be used to match a defined group of individuals having a predetermined or desired relationship.

[0082] The RFID transponder is preferably used to store certain information identifying each play participant and/or describing certain powers or abilities possessed by an imaginary role-play character. For example, players may advance in a magic adventure game by finding clues, casting spells and solving various puzzles presented. Players may also gain (or lose) certain attributes, such as magic skills, magic strength, fighting ability, various spell-casting abilities, combinations of the same or the like, based on game play, skill-level and/or the purchase of collateral play objects. Some or all of this

information is preferably stored on the RFID transponder 118 so that the character attributes may be easily and conveniently transported to various compatible play facilities, games, video games, home game consoles, hand-held game units, and the like. Alternatively, only the UPIN and/or UGIN are stored on the transponder 118 and all other desired information is stored on a computer-accessible database indexed by UPIN and/or UGIN.

[0083] Operation of the transponder 118 (and/or other wireless communication devices described later) is preferably controlled by internal activation circuitry 115 comprising, in the particular embodiment illustrated, a pair of series-connected mercury tilt sensors 122 and 124 (represented in the corresponding schematic diagram as switches S1 and S2, respectively). As illustrated in FIGS. 2A and 2B each mercury tilt sensor 122, 124 comprises a sealed, evacuated glass bulb 130 within which is contained a small ball of liquid mercury. A pair of electrical leads 134 extends through the glass bulb 130 at the sealed end thereof and form closely spaced contacts 136. In one orientation (e.g., FIG. 2B) the ball of mercury 132 is drawn by gravity to cover or envelope the contacts 136, thus completing the electrical circuit and closing the switch S1/S2 (ON state). In all other orientations (e.g., FIG. 2A) the ball of mercury 132 does not contact or envelope both contacts 136 and, thus, the circuit remains open (OFF state). The particular orientation and tilt angle required to trigger either ON or OFF conditions will depend on the size of the glass bulb 130, amount of contained mercury 132 and the size and spacing of contacts 136. If mercury sensors are used, preferably they are encased in a metal and/or epoxy jacket so as to ensure against breakage and possible health and environmental hazards. Preferably, each mercury sensor is encased in epoxy within a sealed stainless steel ferule.

[0084] Alternatively, one or more micro-ball tilt sensors 136 or 138 may be used instead of or in addition to mercury switches 122, 124. For example, FIGS. 3A and 3B are schematic illustrations of a micro-ball tilt switch 136 (normally closed configuration) that may be adapted for use in accordance with an alternative embodiment of the invention. The tilt switches 136, 138 generally comprise upper and lower conductive enclosures 142, 146, respectively, separated by a suitable insulating material 144 and a conductive ball 140 that is free to move within. In one orientation (e.g., FIG. 3A) the internally contained conductive ball 140 rests within an annular groove completing the electrical circuit between the top conductive enclosure 142 and bottom conductive enclosure 146 (ON state). But, when the sensor 136 is tilted by an amount greater than angle α (FIG. 3B), the ball 140 rolls away from the lower conductive enclosure 141 and, thus, the circuit is opened (OFF state).

[0085] FIGS. 4A and 4B are schematic illustrations of another embodiment of a micro-ball tilt switch 138 (normally open configuration) that may also be adapted for use in accordance with a further alternative embodiment of the present invention. In this case, in a first orientation (e.g., FIG. 4A) an internally contained conductive ball 140 rests within a central conical pocket formed in the lower conductive enclosure 146 and is thereby prevented from contacting and completing electrical connection to the upper conductive enclosure 142 (OFF state). But, when the sensor 138 is tilted by an amount greater than angle α (FIG. 4B) the ball 140 rolls out of the conical pocket, touching and completing the circuit with the upper conductive enclosure 142 (ON state). The particular orientation and range of tilt angles required to trigger either

ON or OFF conditions of micro-ball sensors **136**, **138** can be varied and/or adjusted to meet varying needs and skill levels of wand users.

[0086] Referring to FIGS. **5A** and **5B** tilt sensors **122** and **124** are preferably oppositely oriented and spaced apart between opposite ends of the tube **110**, as illustrated. Those skilled in the art will appreciate from the disclosure herein that in virtually any static position of the wand **100** at least one of tilt sensors **122**, **124** will be in the OFF state. Thus, the transponder **118** can essentially only be activated when the wand is in a non-static condition or, in other words, when the wand is in motion. More specifically, the placement and orientation of the tilt sensors **122**, **124** is preferably such that different accelerations or motions are required at the proximal and distal ends **112** and **114** in order to trigger both tilt sensors **122**, **124** to their ON positions (or OFF positions, as the case may be) and, thus, to enable or activate transponder **118** (or other wireless communication devices described later).

[0087] As illustrated in FIG. **5A**, when the wand **100** is held in an upright orientation, tilt sensor **122** (**S1**) is in its ON state (Static-ON) and tilt sensor **124** (**S2**) is in its OFF state (Static-OFF). Because the sensors are wired in series, the activation circuit **115** is OFF (open circuit) and the transponder **118** is disabled. Of course, those skilled in the art will readily appreciate from the disclosure herein that if transponder **118** requires a short circuit to disable, then the sensors **122** and **124** would preferably be wired in parallel and, in the orientation shown, the activation circuit **115** would be shorted through **S1**. On the other hand, when the wand **100** is held in an upside down orientation (FIG. **5B**), tilt sensor **122** (**S1**) is in its OFF state (Static-OFF) and tilt sensor **124** (**S2**) is in its ON state (Static-ON) such that the activation circuit **115** remains OFF (open circuit) and the transponder **118** remains disabled. Again, if transponder **118** requires a short circuit to disable, then the sensors **122** and **124** would preferably be wired in parallel and, in the orientation shown, the activation circuit **115** would be shorted through **S2**.

[0088] Advantageously, the wand activation circuit **115** in accordance with the above-described preferred embodiment is essentially only activated (and transponder **118** is only enabled) when a user actively moves the wand **100** in such particular way as to impart different transient acceleration forces on the distal and proximal ends of the wand **100** (or wherever the sensors are located if not at the distal and proximal ends). In particular, the transient acceleration forces must be sufficient enough at one end of the wand to overcome the gravitational forces acting on the upper sensor (Static-OFF), but not sufficient enough at the other end to overcome the gravitational forces acting on the lower sensor (Static-ON). This transient condition is illustrated in FIG. **6**.

[0089] The wand activation circuit **115** (and, thus, transponder **118**) is activated by holding the wand tilted slightly upward in one hand while gently and smoothly waving it so that the distal end **114** of the wand follows an upward-cresting arcing pattern while the proximal end **112** remains relatively steady or follows a smaller, more gentle arcing pattern. The acceleration forces caused by the upward arcing motion at the distal end **114** counteract gravitational forces on the tilt sensor **124** and cause it to switch from its OFF state to its ON state. At the same time, the smaller arcing motion and acceleration forces at the proximal end **112** are not sufficient to counteract the gravitation forces on the tilt sensor **122** and, thus, it remains in its ON state. The result is that both sensors **122** and **124** are momentarily in their ON state and the wand activation

circuit **115** thereby momentarily activates the transponder **118**. The complexity and learnability of the described motion is similar to a golf swing. Only with this particular motion (or other similar learned motions) executed in a precise and repeatable fashion will the transient conditions be satisfied to cause both sensors **122** and **124** to switch to their ON state, thereby momentarily activating transponder **118**. If the arcing motion is too fast or too pronounced, the lower sensor **122** will switch to its OFF state. On the other hand, if the arcing motion is too slow or too shallow, the upper sensor **124** will not switch to its ON state. Thus, successful operation of the wand **100** requires real skill, patience and training.

[0090] Those skilled in the art will readily appreciate and understand from the disclosure herein that various additional and/or alternative wand activation circuits can be designed and configured so as to respond to different desired wand activation motions. For example, this may be achieved by adding more sensors and/or by changing sensor positions and orientations. For example, one wand motion may trigger a first wand activation circuit (and a first wand effect) while a different wand motion may trigger a second wand activation circuit (and a second wand effect). The number, type and complexity of wand motions and corresponding wand activation circuits are limited only by design and cost considerations and user preferences. Most desirably 6-12 unique wand activation motions and corresponding wand activation circuits are provided. Of course, those skilled in the art will recognize from the disclosure herein that multiple wand activation circuits may share one or more sensors and/or other supporting circuitry and components, as required or desired. Alternatively, a single, multi-mode wand activation circuit may be provided that can respond to multiple wand motions.

[0091] The degree of difficulty and skill required to master each wand motion can preferably be adjusted to suit the age and skill-level of each user. Generally speaking, selecting tilt sensors **122**, **124** having narrow activation ranges increases the difficulty level of the wand, as it makes it more difficult to satisfy the transient conditions required to turn each sensor to its ON or active state. Similarly, adding more sensors also increases the difficulty level, as it decreases the probability that all required transient conditions can be satisfied in a given moment. Placement and orientation of the sensors **122** and **124** (and any other sensors) can also make a difference in the degree of difficulty and skill required. For example, spacing the sensors closer together (e.g., 3-5 cm apart) generally makes it more difficult to operate the wand as it becomes harder and harder to create different transient conditions relative to each sensor location. Conversely, spacing sensors farther apart (e.g., 10-35 cm apart) makes it easier. An optimal sensor spacing is about 8-12 cm. Optionally, some or all of these degree-of-difficulty parameters can be adjusted or changed as skill-levels increase or as other circumstances warrant.

[0092] Of course, those skilled in the art will appreciate from the disclosure herein that the wand activation circuitry **115** is not limited to those including mercury or micro-ball tilt sensors, as illustrated, but may be practiced using a wide variety of other motion and/or tilt sensors and/or other supporting circuitry elements and components that are selected and adapted to the purposes described herein. These include, without limitation, impact sensors, micro-sensors, gyro-sensors, force sensors, micro-switches, momentum sensors, vibration sensors, gravity sensors, accelerometers, and all variety of reed switches (gravity, momentum, magnetic or

otherwise). Moreover, any one or more of these and/or other similar sensor devices may also be used in conjunction with other supporting circuitry elements or components (either internal or external to the wand 100) as desired, including microprocessors, computers, controller boards, PID circuitry, input/output devices, combinations of the same and the like. Mercury and micro-ball tilt sensors as illustrated and described above are particularly preferred as they are relatively inexpensive and reliable.

[0093] FIG. 7 is a schematic illustration of an alternative embodiment of an interactive wand 100a including an optional RF/IR module adapted for long-range wireless communications (up to about 100 meters). Wand 100a is essentially the same as wand 100 illustrated and described above in connection with FIG. 1, except longer-range wand operation is achieved by replacing the RFID transponder 118 in wand 100 (FIG. 1) with an auxiliary RF/IR transmitter 150 (see FIGS. 22 and 25 accompanying discussion for circuit schematic and other details). If line of sight or directional actuation is desired, an infrared LED transmitter of the type employed in standard television remote controls may be provided instead of or in addition to the RF transmitter 118, as those skilled in the art will readily appreciate. In the latter case, a hole (not shown) would preferably be provided in the distal end 114 of the wand to accommodate the transmitting LED of the IR transmitter circuit. Of course, a wide variety of other wireless communications devices, as well as various optional sound and lighting effects may also be provided, as desired.

[0094] RF/IR transmitter module 150 and/or any other desired optional effects may be actuated using the wand activating circuit 115 substantially as illustrated and described above in connection with FIGS. 1-6. As illustrated in FIG. 7, tilt sensors 122, 124 (S1/S2) are wired in series with the RF/IR module, between batteries 152 (voltage source V+) and ground (all or part of tube 110). Thus, RF/IR module 150 is powered when sensors 122 and 124 are both in their ON state (switches S1 and S2 are both closed). Again, this transient state can essentially only be achieved when a skilled user actively moves the wand 100a in such particular way as to impart different transient acceleration forces on the distal and proximal ends of the wand 100a, as illustrated and described above in connection with FIG. 6. Other than as noted above it will be understood that the wand 100a is in all other material respects essentially the same as wand 100 illustrated and described in connection with FIGS. 1-5. Note that the handle 120a and knob 123a are slightly modified, as these elements are preferably uniquely customized/personalized for each wand and/or wand user as will be discussed in more detail later.

[0095] Furthermore, the wand activation circuitry 115 may advantageously comprise a microprocessor that communicates with the sensors 122, 124 and the transmitter module 150. In one embodiment, the microprocessor receives at least one signal from the sensors 122, 124 indicative of the state of the sensors. For instance, the microprocessor may determine when each of the sensors 122, 124 are in an ON or an OFF state or when one of the sensors 122, 124 switches states. Based on the states of the sensors 122, 124, the microprocessor then outputs a signal to the transmitter module 150 that causes activation or deactivation of the transmitter module 150.

[0096] In another embodiment, the microprocessor is capable of measuring a duration of time related to the opera-

tional states of the sensors 122, 124. For example, the microprocessor may use a clock signal or an external timer to determine the duration of time during which at least one of the sensors 122, 124 is in an ON state. The microprocessor may then use this duration of time when outputting a signal to the transmitter module 150. For example, the microprocessor may correlate the duration of time that a sensor 122, 124 is activated (e.g., in an ON state) with an intensity, level, or type of a "spell" being cast by the user. For instance, if the user, while "casting a spell," is able to move the wand 100 so as to keep at least one of the sensors 122, 124 activated for a certain period of time, the microprocessor may assign a particular level or intensity to the spell being cast. Thus, the microprocessor may output different signals, which represent different spells or spell intensities, to the transmitter module 150 based on the length of time of the sensor activation. In one embodiment, the microprocessor may associate longer durations of sensor activation with higher intensity spells.

[0097] In yet other embodiments, the microprocessor calculates the duration of time between successive activations, or triggering, of the sensors 122, 124. For example, the microprocessor may determine how much time passes between the activation of the sensor 122 and the activation of the sensor 124, which are caused by the user's operation of the wand 100. For instance, the microprocessor may associate simultaneous or shorter durations of time between the activations of the two sensors 122, 124 with a more advanced, or higher-level, spell. Thus, the user that operates the wand 100 so as to activate each of the sensors 122, 124 within a relatively short period of time is able to cast higher-level spells. On the other hand, if there is a greater delay between the activations of the sensors 122, 124, the microprocessor assigns a lower intensity level to the spell being cast. In yet other embodiments, the time during or between the sensor activations is used by the microprocessor to determine which of a variety of spells is achieved by the user.

[0098] In other embodiments, the microprocessor may compare the duration of time of sensor activation or time between successive activations, to a predetermined time. For example, if the duration of time between successive activations is less than the predetermined time, the "spell" may be assigned a higher intensity level. If the duration of time between successive activations is greater than the predetermined time, the "spell" may be assigned a higher lower level. In addition, in some embodiments, the microprocessor does not calculate the specific value of the duration of time but determines if the duration of time exceeds or does not exceed a predetermined time.

[0099] In yet other embodiments of the invention, the duration of time during or between activation of the sensors 122, 124 is output to a receiver external to the wand 100. The receiver then processes the duration of time in determining which effect, or which level of an effect, is caused by the particular wand activation motions and associated duration(s) of time. In yet other embodiments, the foregoing microprocessor may be used in a wand 100 comprising a transponder 118 instead of, or in combination with, the transmitter module 150.

[0100] In another embodiment, the microprocessor accesses a look-up table that associates specific durations of time, or ranges of durations of time, with the intensity or the type of the spell being cast. For example, the look-up table may associate durations of time less than 0.1 seconds between successive sensor activations with a higher level spell, dura-

tions of time from 0.1 to 0.2 seconds with a mid-level spell, and durations of time greater than 0.2 seconds with a lower level spell. In one embodiment, the look-up table is stored in a memory, such as for example a read-only memory (ROM), on the wand **100**. The look-up table may be internal or external to the microprocessor. In yet other embodiments, the look-up table may be accessible by the receiver of the signal from the wand **100**.

[0101] FIG. **8** is a schematic illustration of a further alternative embodiment of an interactive wand toy including an optional magnetic inductance energy source. Wand **100b** is essentially the same as wand **100** illustrated and described above in connection with FIG. **1**, except that batteries **152** are replaced with a magnetic inductance energy generator **162**. The magnetic inductance energy generator **162** comprises an inductance coil **L1** sized and arranged such that when it is exposed to a fluctuating magnetic field (e.g., a moving permanent magnet **164** rubbed back and forth and/or an externally generated electromagnetic field) an alternating current is generated. This generated current is rectified by diode **D1** or, alternatively, a full wave bridge rectifier (not shown), and charges preferably an electrolytic capacitor **C1** until it reaches a predetermined operating voltage **V+**. If desired, a voltage regulator device, such as a zener diode (not shown) and/or active regulation circuitry may be added to stabilize and increase the efficiency of the magnetic inductance energy generator **162**.

[0102] Alternatively, those skilled in the art will appreciate from the disclosure herein that a various magnetic field effect sensors, such as Wiegand sensors and the like, may readily be used in place of or in addition to inductor **L1** where, for example, it is desired to increase the energy-generating efficiency of the circuit **162**. For example, U.S. Pat. No. 6,191,687 to Dlugos discloses a Wiegand effect energy generator comprising a Wiegand wire that changes its magnetic state in response to being exposed to an alternating magnetic field. The Wiegand wire has core and shell portions with divergent magnetic properties. The magnetic properties of the wire are such that it produces an output power signal that corresponds to the strength and rate of change of a magnetic field to which the Wiegand wire is exposed. Such energy pulses generally are between about 5 and 6 volts and 10 microseconds in width. Such energy pulses have sufficient voltage and duration to power a low power transmitter such as RF/IR module **150**. One suitable Wiegand sensor that may be utilized in accordance with the present invention is the series **2000** sensor sold by EHD Corp. The Series **2000** Wiegand sensor produces pulses in response to alternating magnetic fields or permanent magnets that pass near the sensor.

[0103] The energy generating circuit **162** is preferably such that the wand **100b** has no movable parts and requires no maintenance such as replacing batteries or the like over its anticipated life. All energy is generated and stored by rubbing the wand back and forth with a permanent magnet and/or by placing the wand within an externally generated electromagnetic field. Preferably, the inductor **L1** (or Wiegand wire) and capacitor **C1** are selected such that 5-10 seconds of exposure to an external fluctuating magnetic field will fully charge the capacitor **C1**, thus enabling the wand RF/IR transmitter to be activated at least once and preferably 5-20 times without having to recharge. Advantageously, the absence of replaceable batteries or other visible electronic technology significantly increases the reality and full immersion experience of the magical fantasy and gives users the feeling of practicing,

performing and mastering “real” magic using a “real” magic wand **100b**. Optionally, a non-replaceable permanent rechargeable battery and/or a factory replaceable battery (not shown) may be provided in place of or in addition to the energy generating circuit **162** where it is desired to provide long-term energy storage. Other than replacing batteries **152** with magnetic inductance energy generator **162**, the wand **100b** is in all other material respects essentially the same as wand **100a** illustrated and described above in connection with FIG. **7**. Note that the handle **120b** and knob **123b** are slightly modified, as these elements are preferably uniquely customized/personalized for each wand and/or wand user as will be discussed in more detail later.

[0104] FIG. **9** is a schematic illustration of a further alternative embodiment of an interactive wand toy including an optional piezoelectric generator. Wand **100c** is essentially the same as wand **100b** illustrated and described above in connection with FIG. **8**, except that magnetic inductance energy generator **162** has been replaced with a piezo generator **166** and power supply **168**.

[0105] Piezoelectricity refers to a unique property of certain materials such as quartz, Rochelle salt, and certain solid-solution ceramic materials such as lead zirconate-titanate ($\text{Pb}(\text{Zr}_{1-x}\text{Ti}_x)_2$) (“PZT”) that causes induced stresses to produce an electric voltage or, conversely, that causes applied voltages to produce an induced stress. In a “generator” mode, electricity is developed when a piezoelectric (“piezo”) crystal is mechanically stressed. Conversely, in a “motor” mode, the piezo crystal reacts mechanically when an electric field is applied.

[0106] PZT is one of the leading piezoelectric materials used today. It can be fabricated in bimorph or unimorph structures (piezo elements), and operated in flexure mode. These structures have the ability to generate high electrical output from a source of low mechanical impedance (conversely, to develop large displacement at low levels of electrical excitation). Typical applications include force transducers, spark pumps for cigarette lighters and boiler ignition, microphone heads, stereophonic pick-ups, etc.

[0107] It is known that piezo elements can be used to generate small amounts of useful energy from motion. For example, U.S. Pat. No. 3,456,134 to Ko, incorporated in its entirety by reference herein, discloses a piezoelectric energy converter for electronic implants, wherein body motion is converted into electrical energy using a piece of piezoelectric PZT in the form of a resonant cantilever beam. See also, U.S. Pat. No. 6,438,193 to Ko et. al, which discloses a similar piezo generator for self-powered tire revolution counter. Such piezo generators have particular application and benefit to battery-less toys and wands of the type disclosed and described herein.

[0108] FIG. **10** is a cross-sectional view of such a piezo generator **166** comprising a “bimorph” piezo element **170** rigidly mounted at one end forming a cantilever beam. A “bimorph” is a flexing-type piezoelectric element, which has the capacity for handling larger motions and smaller forces than single piezoelectric plates. The bimorph piezo element **170** comprises two planar piezo crystals secured together face-to-face with a shim or vane therebetween. Mechanical bending of the element **170** causes it to produce a corresponding voltage between output electrodes **176**, **178**.

[0109] The piezoelectric element **170** is mounted and enclosed within the distal end of tube **110** (FIG. **9**) and its free end is loaded with a small weight **174** selected to resonate at

a suitable frequency corresponding to the likely or anticipated movement of the wand **100c**. A typical measured oscillation frequency is on the order of 10-100 Hz. As the wand is moved periodically, the piezo element **170** vibrates back and forth producing electrical pulses. These electrical pulses are then rectified by a full wave bridge rectifier **180** (FIG. **11**), are filtered by a filter circuit comprising capacitors **C1**, **C2** and resistors **R0**, **R1** and are stored in an energy storage capacitor **C3**, preferably a low-voltage electrolytic capacitor.

[**0110**] In order to draw maximum power from the piezo element **170**, the power supply circuit **168** "load" impedance preferably is selected to match the output impedance of the piezo element **170**. In order to minimize the ripple effect (peak-to-peak magnitude of rippling imposed on the nominal DC voltage level) energy storage capacitor **C3** is preferably selected to be as large as possible, given available space constraints. To improve the stability of the power-supply an optional voltage regulator **182** may be added. For example, an LM185° C. band-gap voltage regulator may be chosen.

[**0111**] The piezo generator and power supply circuits **166**, **168** preferably have sufficient power output under normal operating conditions such that the wand **100c** requires no other internal energy sources such as replaceable batteries or the like. All energy is generated and stored by normal motion of the wand during use, e.g. during spell casting or during normal walking or running while carrying the wand **100c**. Preferably, the energy storage capacitor **C3** is selected such that when fully charged, it provides sufficient stored energy to enable the wand to be activated at least once and preferably 50-100 times without having to recharge. Advantageously, the absence of replaceable batteries or other visible electronic technology significantly increases the reality and full immersion experience of the fantasy and gives users the feeling of practicing, performing and mastering "real" magic using a "real" magic wand **100c**. Optionally, a non-replaceable permanent rechargeable battery and/or a factory replaceable battery (not shown) may be provided in place of or in addition to the energy generating circuit **166** where it is desired to provide long-term energy storage. The wand **100c** in all other material respects is essentially the same as wand **100b** illustrated and described above in connection with FIG. **8**. Note that the handle **120c** and knob **123c** are slightly modified, as these elements are preferably uniquely customized/personalized for each wand and/or wand user as will be discussed in more detail later.

[**0112**] FIG. **12** is a schematic illustration of a further alternative embodiment of an interactive wand toy including an RF/IR module and optional RFID transponder. Wand **100d** is essentially the same as wand **100b** illustrated and described above in connection with FIG. **8**, except for the addition of optional RFID transponder **118d**.

[**0113**] As with the RFID transponder **118** illustrated and described above in connection with FIG. **1**, RFID transponder **118d** is operable to provide relatively short-range RF communications (less than about 200 cm) using one or more RFID reader units or reader/writer units, described in more detail later. The transponder **118d** also preferably contains certain electronics comprising a radio frequency tag pre-programmed with a unique person identifier number ("UPIN"). The UPIN may be used to identify and track individual wands and/or play participants. Optionally, each tag **118d** may also include a unique group identifier number ("UGIN") which may be used to match a defined group of individuals having a predetermined or desired relationship.

[**0114**] The RFID transponder is preferably used to store certain information identifying each play participant and/or describing certain powers or abilities possessed by an imaginary role-play character. For example, players may advance in a magic adventure game by finding clues, casting spells and solving various puzzles presented. Players may also gain (or lose) certain attributes, such as magic skills, magic strength, fighting ability, various spell-casting abilities, combinations of the same or the like, based on game play, skill-level and/or the purchase of collateral play objects. Some or all of this information is preferably stored on the RFID transponder **118d** so that the character attributes may be easily and conveniently transported to various compatible play facilities, games, video games, home game consoles, hand-held game units, and the like. Alternatively, only the UPIN and UGIN are stored on the transponder **118** and all other desired information is stored on a computer-accessible database indexed by UPIN and/or UGIN.

[**0115**] If desired, RFID transponder **118d** may be electronically interlocked and controlled by a corresponding wand activation circuit such as illustrated and described above in connection with FIG. **1**. More preferably, however, the RFID tag **118d** is not interlocked, but is always activated. In this manner, transponder **118d** can be easily read at short range using an RFID reader/writer (described later) to sense and track play participants and/or to activate various simple wand effects. Longer range RF communications via RF/IR module **150** are preferably only enabled when an appropriate wand activation motion is executed as described above in connection with FIGS. **1-6**. The wand **100d** in all other material respects is essentially the same as wand **100b** illustrated and described above in connection with FIG. **8**. Note that the handle **120d** and knob **123d** are slightly modified, as these elements are preferably uniquely customized/personalized for each wand and/or wand user as will be discussed in more detail later.

[**0116**] FIG. **13** is a schematic illustration of a further alternative embodiment of an interactive wand toy including an RF/IR module and optional RFID transponder. Wand **100e** is essentially the same as wand **100d** illustrated and described above in connection with FIG. **12**, except for the location and placement of the RFID transponder **118e**.

[**0117**] As with the RFID transponder **118d** illustrated and described above in connection with FIG. **12**, RFID transponder **118e** provides relatively short-range RF communications using one or more RFID reader units or reader/writer units, described in more detail later. The transponder **118e** also preferably contains certain electronics comprising a radio frequency tag pre-programmed with a unique person identifier number ("UPIN") and unique group identifier number ("UGIN"). Preferably, RFID tag **118e** is always activated so that it can be easily read at short range using an RFID reader/writer (described later) to sense and track play participants and/or to activate various simple wand effects. Placing the RFID tag **118e** in the handle **120e**, allows for modular construction and functionality of a wand **100e** as auxiliary handles may be interchanged having other unique RFID tags with unique stored information. Optionally, the tag-containing handle **120e** and knob **123e** may be omitted altogether in the case, for example, where a less expensive wand is desired.

[**0118**] As described above, longer range RF communications via RF/IR module **150** are preferably enabled only when an appropriate wand activation motion is executed as described above in connection with FIGS. **1-6**. The wand

100e in all other material respects is essentially the same as wand **100d** illustrated and described above in connection with FIG. 12. Note that the handle **120e** and knob **123d** are slightly modified, as these elements are preferably uniquely customized/personalized for each wand and/or wand user as will be discussed in more detail later.

[0119] In certain advanced applications, it is desirable to wirelessly communicate specific data and commands to achieve different or varied wand effects. For example, it may be desirable to wirelessly send one command signal that turns a certain object (e.g., a lamp) “OFF” and another command signal that turns an object “ON”. As described above in connection with FIGS. 1-6, this functionality may be achieved using multiple wand activation circuits (or a single multi-mode circuit) responsive to various unique wand motions whereby each wand motion, if executed successfully, causes a different RF or IR signal to be transmitted to control or activate the desired effect (e.g., turning a light ON or OFF or simulating the levitation of an object).

[0120] Another convenient way to achieve similar functionality is to load data bits representing specific desired commands directly into a data buffer of RF/IR module **150f** (FIG. 14A) and then, using only a single wand activation circuit and a single learned wand motion, cause an RF or IR signal to be transmitted, thereby carrying the command signal and data to an RF or IR receiver and associated effect. Thus, for example, one or more tilt sensors **192**, **194** (illustrated schematically as switches **S3/S4**) may be provided in a convenient location within the wand **100f** (e.g., within the handle **120**). These sensors are preferably mounted and oriented such that axial rotation of the wand shaft **110** and/or wand handle **120f** causes the sensors to alternately switch from their ON to their OFF state. As illustrated in the circuit schematic accompanying FIG. 14A, Each sensor controls one data input bit of the RF/IR module data bus (e.g., **S3**, **S4**).

[0121] Preferably, sensors **192**, **194** are disposed at an angle of between about 60 and 120 degrees (most preferably about 90 degrees) from one another within a transverse plane of the wand (see, e.g., FIG. 14B). Those skilled in the art will readily appreciate that in this manner, four possible wand orientations are possible resulting in four unique sensor pair states as follows: ON/ON; OFF/OFF; ON/OFF and OFF/ON. These four sensor states can represent, for example, four unique command signals sent using the RF/IR module **150f**. The wand **100f** in all other material respects is essentially the same as wand **100b** illustrated and described above in connection with FIG. 8. Note that the handle **120f** and knob **123f** are slightly modified, as these elements are preferably uniquely customized/personalized for each wand and/or wand user as will be discussed in more detail later.

[0122] Where it is desired to send a larger number of unique command signals, various combinations of additional orientation sensors and/or wand activation circuits may be added, as desired. Alternatively, various dials, switches and/or other inputs may be provided for selecting from a number of unique wand commands or “spells.” For example, in one preferred embodiment illustrated in FIGS. 15A-C a wand **100g** is provided including a knob-actuated rotary switch **202** which directly loads up to 4 data bits (up to 16 possible unique codes) representing specific desired commands directly into a data buffer of RF/IR module **150g** (FIG. 15A).

[0123] As illustrated in FIG. 15C a user rotates the knob **123g** and sets it to the desired spell represented by magic symbols **204** (FIG. 15D). Then, using only a single wand

activation circuit and a single learned wand motion, the user causes an RF or IR signal to be transmitted, carrying the unique command signal/data to an RF or IR receiver, thereby controlling or activating an associated effect. Alternatively, a potentiometer may be used in conjunction with an ND converter circuit instead of rotary switch **202** for selecting wand functions/spells. The wand **100g** in all other material respects is essentially the same as wand **100b** illustrated and described above in connection with FIG. 8. Note that the handle **120g** and knob **123g** are slightly modified, as these elements are preferably uniquely customized/personalized for each wand and/or wand user as will be discussed in more detail later.

[0124] FIG. 16A is a schematic illustration of a further alternative embodiment of an interactive wand toy including optional touch sensor elements for selecting one or more wand spell commands. Wand **100h** is essentially the same as wand **100f** illustrated and described above in connection with FIGS. 14A and 14B, except for the substitution of touch sensor elements **208**, **210**, **212** for tilt sensors **192**, **194**.

[0125] Touch sensor elements **208**, **210**, **212** (represented in the accompanying schematic as **S3**, **S4**, **S5**) comprise solid-state electronic switches (no buttons or moving parts) that are activated by the simple touch of a finger. Most preferably, these are solid state touch switches of the type illustrated and described in U.S. Pat. No. 4,063,111 to Dobler et al., the entire contents of which are incorporated herein by reference. As illustrated in FIG. 16B, each touch switch contact element **208**, **210**, **212** is preferably formed from a pair of conductive electrodes **211** surrounded by, and preferably flush with, an insulating material **213**. If desired, the electrodes **211** may be shaped in the form of magic symbols or other shapes consistent with a desired magic theme, as illustrated. During use, the user's finger **217** is placed over the pair of electrodes **211** and thereby forms a portion of an electronic circuit to change the state of a corresponding solid state electronic switching device **Q1**, **Q2**, **Q3** in communication therewith, such as a MOSFET or PNP transistor. The touch sensor is thereby actuated.

[0126] Each touch sensor preferably controls one data input bit of the RF/IR module data bus (e.g., **S3**, **S4**, **S5**). One or more touch switches may be activated during a single wand transmission. Thus, those skilled in the art will readily appreciate that eight possible combinations of touch switch activations are possible corresponding to eight unique command input data sets as follows: ON/ON/ON; OFF/OFF/ON; ON/OFF/ON; OFF/ON/ON; ON/ON/OFF; OFF/OFF/OFF; ON/OFF/OFF, and OFF/ON/OFF. These eight sensor states can represent, for example, eight unique command signals sent using the RF/IR module **150h**.

[0127] As illustrated in FIGS. 16C and 16D, a user may select a spell by touching one or more selected magic symbols. Then, while holding the fingers over the selected magic symbols and using only a single wand activation circuit and a single learned wand motion, the user causes an RF or IR signal to be transmitted, carrying the unique command signal/data to an RF or IR receiver, thereby controlling or activating an associated effect.

[0128] Optionally, wand **100h** includes a magnetic tip **216**, as illustrated in FIG. 16A. This can be especially useful and entertaining for close-range activation of various play effects, such as turning lights on/off, triggering special sound and/or lighting effects. For example, FIGS. 17A-17B are time-sequenced illustrations of one embodiment of a magnetically actuated lighting effect using the interactive wand toy **100h**

with optional magnetic tip **216**. A magnetic reed switch **218** is provided in series between the desired lighting effect **220** and a power source (V+). The reed switch is constructed in the normal fashion. Contacts **222**, **224** are normally open and, thus, the lighting effect **220** is in its OFF state. But, when the magnetic tip **216** of wand **100h** is brought into relatively close proximity (2-3 cm) with the reed switch **218**, contact elements **222**, **224** are magnetized by the magnetic field lines and are drawn toward each other. This causes the contacts **222**, **224** to immediately attract, closing the gap and completing the circuit to turn on the lighting effect **220**. Of course, those skilled in the art will appreciate from the disclosure herein that various relays, power controllers and the like may be required or desirable to provide adequate control of larger, more complex effects. But all such effects, no matter how small/simple or large/complex, may be triggered with a simple reed switch **218** and a wand **100h** having a magnetic tip **216**, as described above.

[0129] The magnetic tip **216** is especially useful and synergistic in combination with the other disclosed functions and features of wand **100h**. Thus, for example, as illustrated in FIG. 17C, a desired lighting effect is controlled by RF/IR receiver **250**, which is adapted to receive an RF and/or IR command signal from wand **100h**. The RF/IR receiver **250** (and/or the lighting effect **220**) is also controlled by series-connected magnetic reed switch **218**, as illustrated and described above (FIGS. 17A, 17B). Desirably, this allows a user to use the wand **100h** and the magnetic tip **216** thereof to select one or more effects he or she wishes to control or activate. For example, the closure of the magnetic reed switch **218** sends an activation signal to RF/IR receiver **250**. In response, the receiver initiates a timer (e.g., 5-10 seconds) wherein its RF and/or IR receiver circuitry is activated and ready to receive one or more transmitted commands for controlling the associated effect **220**. Thus, a user may select to control the lighting effect **220** by activating the reed switch **218** with the magnetic tip **216** of wand **100h**. Then the user may cast a spell (cause the wand **100h** to transmit an RF or IR command signal) that commands the RF/IR receiver **250** to turn the lighting effect ON or OFF, to change the lighting effect (e.g., change its color or intensity), and/or launch a related effect (e.g., simulated levitation of the lighting source or other desired effects). In this manner, users can maintain direct and precise control over any number of individual play effects as may be desired. The wand **100h** in all other material respects is essentially the same as wand **100f** illustrated and described above in connection with FIG. 14. Note that handle **120h** and knob **123h** are slightly modified, as these elements are preferably uniquely customized/personalized for each wand and/or wand user as will be discussed in more detail later.

[0130] While it is particularly preferred to provide battery-less RF-enabled, RFID-enabled or IR-enabled wand **100**, those skilled in the art will recognize from the disclosure herein that the invention may be carried out in a variety of other ways that incorporate some or all of the inventive features disclosed and described herein. For example, wand activation circuit **115** may be implemented in a variety of other gaming and entertainment applications such as, for example, a wireless or hard-wired wand input device for a video game, computer game or home game console, an arcade or redemption challenge device, home-operated amusement device using simple bells and buzzers, or the like. Alternatively, some or all of the various circuitry and components described

herein above may be externally implemented such that the wand **100** may not be entirely self-contained, but may rely on certain external components and circuitry for some or all of its functionality. Alternatively, some or all of the various circuitry and components described herein can be implemented in a user-wearable format such that various interactive play effects and the like, as described herein, may be actuated through particular hand or arm motions without the use of a wand.

[0131] Additional optional circuitry and/or position sensors may be added, if desired, to allow the “magic wand” **100** to be operated by waiving, shaking, stroking and/or tapping it in a particular manner. If provided, these operational aspects would need to be learned by play participants as they train in the various play environments. The ultimate goal, of course, is to become a “grand wizard” or master of the wand. This means that the play participant has learned and mastered every aspect of operating the wand to produce desired effects within each play environment. Of course, additional effects and operational nuances can (and preferably are) always added in order to keep the interactive experience fresh and continually changing. Optionally, as shown and discussed in more detail in connection with FIG. 19G, the wand **100** may be configured such that it is able to display 50 or more characters on a LTD or LCD screen. The wand may also be configured to respond to other signals, such as light, sound, or voice commands as will be readily apparent to those skilled in the art.

[0132] Proximity Sensor

[0133] In yet another embodiment, the wand **100** further comprises a proximity sensor usable to provide a “hover” effect that is indicative of the initialization of a control interlock. When the proximity sensor in the wand **100** is moved within a particular distance of a receiver, such as the RF/IR receiver **150**, and/or an effects controller, a “hover” effect occurs, such as, for example, the turning on of a light, the movement or vibration of an object, or any other perceptible signal (visual or audible) that notifies the user that a play effect may be initiated.

[0134] For instance, one embodiment of the invention may include a play effect that comprises the moving of a book. When the user brings the wand **100** within a predetermined distance from the book (e.g., one meter), the proximity sensor in the wand **100** causes the wand to output a command signal to a receiver and/or effects controller near the book to initiate a control interlock and to generate a “hover” effect, such as the turning on of a light. At this point, the user is notified that he or she may then cast the appropriate spell, such as by appropriately motioning the wand **100**, which causes the book to move. If the user attempts to cast the spell outside of the predetermined distance, the book does not move. This is because the appropriate control interlock is not initiated between the wand **100** and the receiver and/or effects controller.

[0135] Furthermore, the foregoing described “hover” effect may be used with passive RFID technology to conserve energy or battery power of the wand **100**. In one embodiment, the wand **100** comprises a passive RFID circuit in addition to an activation circuit (e.g., activation circuit **115** of FIG. 1) and may operate in an “active” or a “sleep” mode. During the sleep mode, the activation circuit does not engage in significant activity, which reduces the energy consumption of the wand **100**. In addition, during the “sleep” mode, the user may not be able to cast spells with the wand **100**. When the passive

RFID circuit of the wand 100 is brought with a certain range of an RF transmitter, such as positioned near the effects controller, the passive RFID circuit receives the transmitted RF signal and “awakens” the wand activation circuit into the “active” state. At this point, the user is able to engage in spell casting, such as by motioning the wand, as is described herein. In further embodiments, a perceptible signal, such as a light or a noise, alerts the user when the wand 100 awakens to an “active” mode.

[0136] Although disclosed with reference to particular embodiments, a skilled artisan will recognize from the disclosure herein a wide variety of methods and/or devices usable to cause a “hover” effect. For example, the user may use certain voice commands, such as a particular magic word or phrase, to cause the “hover” effect and to initiate a control interlock. In other embodiments, an RFID tag in the wand 100, the receiver, and/or the effects controller is used to initiate the “hover” effect. In yet other embodiments, the proximity sensor is located remote to the wand 100, such as near or in the receiver and/or effects controller.

[0137] Wand Operation

[0138] A magic wand as disclosed and described herein may be used to cast an infinite possibility of “spells” or commands based on a single wand activation circuit, a single learned wand motion and only a few unique wand command signals selected using any of the various circuits and structures described above in connection with FIGS. 14-16 (of course more complex operations are also possible and desirable). For example, using the wand 100g illustrated and described in connection with FIGS. 16A-16D a user can easily transmit three distinct command codes selected by each of the three touch sensors 108, 110, 112. Touching either the “+” or the “-” symbols and waving the wand in the required motion triggers the internal wand activation circuit and causes the wand to transmit a radio frequency (RF) or infrared (IR) signal corresponding to an “ON/CAST” or “OFF/BLOCK” command or spell, respectively. This can be useful, for example, for turning on/off various play effects over long distances (up to 100 meters) and for basic game play such as spell casting competitions, target practice, and the like.

[0139] If it is desired to provide signal directionality so that the command signal or spell can be aimed or cast at various particular selected play effects or objects, then a directional signal source such as IR and/or directionalized RF is preferably selected. Alternatively, a combination of directional (e.g., IR) and omni-directional (e.g., RF) signal sources may be used effectively to provide a desired directional spell-casting capability. For example, a momentum-actuated switch or accelerometer (not shown) internally disposed within the tip of wand 100 can be used to activate a directional signal source (e.g., a light bulb or L.E.D. shining a beam or cone of light) when a predetermined momentum force or acceleration is reached. Such a wand with internal wand activation circuitry and/or a directional signal source may replace, for example, a gun or a rifle in a conventional shooting gallery or target game such as disclosed in U.S. Pat. No. 4,296,929 to Meyer et al. and U.S. Pat. No. 5,785,592 to Jacobsen, both of which are incorporated by reference herein in their entireties.

[0140] Waving and activating the wand while touching the “*” symbol preferably initiates the beginning of a “complex” spell comprising multiple combinations of the first two (base-2 coding) or all three wand motions (base-3 coding). Of

course, those skilled in the art will appreciate that with three touch sensors, up to base-8 coding is possible by including combinations of simultaneously activated sensors. Thus, various spell “recipes” or incantations can be described and carried out using a sequence of individual commands and corresponding wand motions as represented, for example, by the three distinct magic symbols. Table 3, below, illustrates some examples of complex spells/commands that are possible using base-3 coding.

TABLE 1

Spell Formula Effect	
+	“on” or “cast spell”
-	“off” or “block spell”
*	“start complex spell”
*+	“move object”
*-	“stop object”
-+	“start/increase levitation”
*--	“stop/decrease levitation”
++	“unlock/open door”
***-	“lock/close door”
*++	“Fire Spell”
*+-	“Block Fire spell”
*+++	“Ice Spell”
*++-	“Block Ice Spell”

[0141] Using up to 6 combinations of 2 wand motions (base-2), wand users can produce 126 different spells. Using up to 6 combinations of 3 wand motions (base-3), wand users can produce 1092 different spells. Using up to 6 combinations of 8 wand motions (base-8) produces 299,592 different possible spells. There is virtually no limit to the number of different spells that can be created and executed in this fashion. Preferably, once a complex spell is initiated and during each further step thereof a timer is initiated by the associated active receiver module and/or effects controller. If an additional command signal is not received within a predetermined time period (e.g. 0.5-3 seconds) the complex spell is considered “completed” and the effects controller actuates the appropriate relay to trigger whatever appropriate effect(s) correspond to the complex spell received. If the spell is incomplete or is inaccurate in any way, preferably only a “swoosh” or similar sound effect is triggered indicating that a spell was cast but did not work.

[0142] If desired, the active receiver module or associated effects controller can also be configured to give users audible and/or visual cues as each complex spell is being cast. This is in order to help users cast complex spells and help them identify when they have made a mistake or if they are about to cast the wrong or an unintended spell. For example, various themed feedback effects such as glowing lights, halo effects or escalating sound effects can be provided as each step in a complex spell is successfully completed. Again, this helps users learn the spells and understand where they perhaps went wrong in casting a particular spell. It also helps users discover and learn new spells by trial and error experimentation and by memorizing various spell sequences/commands that are observed to produce desired effects.

[0143] Preferably, users participate and advance in an interactive magic experience or game over time (e.g., weeks, months or years) according to a predetermined progression of gaming levels, wand levels and/or experience levels. For example, the various RF receivers disposed within a compatible play space could be programmed so that users of Level-1 wands may only be able to cast spells by actually touching

their wands to whatever object they wish to control/actuate. Users of Level-2 wands would be able to cast simple (e.g., on/cast and off/block) spells over short and medium range distances, but not complex spells. Users of Level-3 wands would be able to cast simple spells (e.g., on/cast and off/block) and some complex spells (e.g., spells requiring up to 3 wand motions) over short, medium and long range distances, but not more complex spells requiring 4 or more wand motions. Users of Level-4 wands would be able to cast all types and varieties of simple and complex spells over short, medium and long distances using any number of wand motions as desired. Certain "master" level users may also be able to program or define their own spells and share them with other users. There is no limit to the number and complexity of spells and corresponding special effects that may be created.

[0144] Wand levels can easily be set and changed, for example, by accessing the internal circuitry of each wand and flipping various dip switches to change the address or coding of the internal RF/IR transmitter. Alternatively, within a play facility wand levels may be set and stored at the receiver/controller level by tracking each wand unique ID code (UPIN/UGIN) and using a computer and an indexed database to look up the corresponding wand level and any other relevant gaming information associated with each unique UPIN/UGIN. Preferably, when a user reaches the appropriate number of points or experience for advancement to the next level, a special congratulatory effect is actuated and the user is thereby notified that he or she has earned additional magic powers. If desired, a short graduation ceremony may be presided over by a "Grand Wizard" while the user's wand is upgraded with new magic powers (e.g., insertion of new electronics and/or adjustment of various dip switches, circuit jumpers, combinations of the same or the like).

[0145] Wand Fabrication, Assembly and Detailing

[0146] One particularly exciting and rewarding aspect of an immersive interactive magic experience in accordance with the present invention is providing users with an opportunity to select, build and/or decorate their own magic wands. Accordingly, preferably all or most of the wand components are standardized, modularized and interchangeable so that various prefabricated wand components and starting materials can be stocked (e.g., in a "wizards workshop") and individually purchased by users to create an endless variety of unique and individualized finished wands having evolving powers, abilities and/or aesthetics.

[0147] For the most fully immersive experience possible it is most desirable that users are not distracted by the underlying technology that makes the wand work, but simply enjoy the immersive fantasy experience of practicing, performing and mastering "real" magic using a "real" magic wand. Thus, preferably most, if not all, of the wand components are simple in outward appearance and preferably contain no conspicuous outward manifestations (or have only minimal outward manifestations) of the technology within. Wand materials and components fabricated from natural or simulated natural materials, such as wood, bone leather, minerals (metals) and crystals are particularly preferred, although certainly not required.

[0148] The base wand component comprises the wand shaft **110**. This may be a hollow plastic, wood or metal shaft provided in various materials and colors. For beginners or entry level users, a finished wand may be constructed by simply selecting a wand shaft **110** and then fitting it with one or more magnetic end caps **216**, as illustrated. This provides

an entry level wand (Level-1) that can be used to activate a variety of simple effects such as illustrated and described above in connection with FIGS. **17A-17C**. If desired, a small wood lathe **230** can be used to create a custom wand handle **120** fabricated from a selected wood stock and a user's choice of any one of a number of available template patterns. If further desired, the end of the handle may be center-drilled to accommodate a threaded stud **121**, bolt or other means for removably securing a selected decorative metal, wood and/or crystal knob **123a-123f**. Such knobs may comprise, for example, any one of a number of standard, internally threaded cabinet knobs or drawer-pulls such as available from Emtek Products Inc. A Level-1 wand constructed in this fashion preferably facilitates basic game play within a compatible play facility, but is not fully functional and, therefore, may not be capable of achieving some of the more desirable play effects or play experiences available.

[0149] The next level wand (Level-2) would preferably include, in addition, a simple passive RFID transponder **118** inserted and secured at one end thereof. The transponder **118** provides relatively short-range RF communications and also stores a unique person identifier number ("UPIN") and an optional unique group identifier number ("UGIN"). The UPIN and UGIN may be used to identify and track individual wands and play participants. The RFID transponder **118** also stores certain information identifying each play participant and/or describing certain powers or abilities possessed by an imaginary role-play character represented by the wand. These stored character attributes may be easily and conveniently transported with the wand to various compatible play facilities, games, video games, home game consoles, hand-held game units, and the like. If desired, the transponder **118** may be encapsulated in a colored epoxy, Lucite or the like and thereby disguised as a natural crystal or mineral/stone. A Level-2 wand preferably facilitates basic and intermediate game play within a compatible play facility. It has more functionality than a Level-1 wand, but is still not fully functional and, therefore, may not be capable of achieving some of the most desirable play effects or play experiences available.

[0150] The next level wand (Level-3) would preferably include, in addition, an active RF/IR module and associated wand activation circuitry for wirelessly casting a simple spell (e.g., ON/OFF) over longer distances. For example, this would be similar to the wand **100d**, illustrated and described above in connection with FIG. **12**. Preferably, the wand would be self powered, requiring no batteries or other replaceable internal power source. However, if replaceable batteries are desired, they may optionally be encapsulated in a colored epoxy, Lucite or the like and thereby disguised and sold in the form of a natural "energy crystal" or mineral/stone. A Level-3 wand preferably facilitates basic, intermediate and some advanced game play within a compatible play facility. It has more functionality than a Level-1 and Level-2 wand and can cast simple spells over long distances, but is not able to cast more complex spells. Therefore, it may not be capable of achieving some of the most advanced and desirable play effects or play experiences available.

[0151] The highest level wand (Level-4) would preferably include, in addition, circuitry and/or structure(s) for selecting and casting more advanced and/or complex spells (e.g., ON/OFF, increase/decrease, UP/DOWN, change colors, simulated levitation, or the like). For example, this would be similar to the wands **100f-100h**, illustrated and described above in connection with FIGS. **14-16**. Preferably, the wand

would be self powered, requiring no batteries or other replaceable internal power source. A Level-4 wand preferably facilitates basic, intermediate and all advanced game play within a compatible play facility. It has more functionality than a Level-1, Level-2 and Level-3 wand and can cast a variety of simple or complex spells over long distances to achieve the most advanced and spectacular magical play effects.

[0152] Preferably, in all cases described above, the wand shaft **110**, handle **120** and/or knob **123** may be further decorated and/or individualized, as desired, with various monograms, engravings, stickers, stains, custom paint and the like, to suit the tastes of each individual user. For example, various assembly and fabrication stations may preferably be provided within a dedicated “workshop” area whereby wand purchasers may personally attend to the selection, fabrication, assembly and final detailing of their personal wands. Similarly, wand “kits” may also be selected, packaged and sold whereby purchasers can assemble and decorate their own wands in the convenience of their own home using the wand components, materials and decorative elements illustrated and described above. FIGS. 19A-19P illustrate various examples of wands, wand handles or grips, wand add-ons, and wand knobs that have been fabricated, assembled and detailed in a manner as described above.

[0153] RFID Tags/Transponders

[0154] Many of the preferred embodiments of the invention illustrated and described above are RFID-enabled—that is, they utilize RFID technology to electrically store and communicate certain relevant information (e.g., UPIN and UGIN, game levels, points, combinations of the same or the like) and/or to wirelessly actuate or control various magical play effects. RFID technology provides a universal and wireless medium for uniquely identifying objects and/or people and for wirelessly exchanging information over short and medium range distances (10 cm to 10 meters). Commercially available RFID technologies include electronic devices called transponders or tags, and reader/writer electronics that provide an interface for communicating with the tags. Most RFID systems communicate via radio signals that carry data either uni-directionally (read only) or, more preferably, bi-directionally (read/write).

[0155] Several examples of RFID tags or transponders particularly suitable for use with the present invention have been illustrated and described herein. For example, in the particular preferred embodiments illustrated and described above, a 134.2 kHz/123.2 kHz, 23 mm glass transponder is preferably selected, such as available from Texas Instruments, Inc. (<http://www.tiris.com>, e.g., Product No. RI-TRP-WRHP). As illustrated in FIG. 21A, this transponder basically comprises a passive (batteryless) RF transmitter/receiver chip **240** and an antenna **245** provided within an hermetically sealed vial **250**. A protective silicon sheathing **255** is preferably inserted around the sealed vial **250** between the vial and the inner wall of the tube **110** to insulate the transponder from shock and vibration. If desired, the RFID transponder **118** may be modified to provide an optional external interrupt/disable line **260**, such as illustrated in FIG. 21A and as described in more detail above in connection with FIGS. 1 and 5.

[0156] However, those skilled in the art will readily appreciate from the disclosure herein that the invention is not limited to the specific RFID transponder devices disclosed herein, but may be implemented using any one or more of a wide variety of commercially available wireless communica-

tion devices such as are known or will be obvious from the disclosure herein to those skilled in the art. These include, without limitation, RFID tags, EAS tags, electronic surveillance transmitters, electronic tracking beacons, Wi-Fi, GPS, bar coding, and the like.

[0157] Of particular interest for purposes of practicing the present invention is the wide variety of low-cost RFID tags that are available in the form of a printed circuit on a thin, flat adhesive-backed substrate or foil. For example, the 13.56 MHz RFID tag sold under the brand name Tag-it™ and available from Texas Instruments, Inc. (<http://www.tiris.com>, Product No. RI-103-110A) has particular advantages in the context of the present invention. Paper thin and batteryless, this general purpose read/write transponder is placed on a polymer tape substrate and delivered in reels. It fits between layers of laminated paper or plastic to create inexpensive stickers, labels, tickets and badges. Tag-it™ inlays have a useful read/write range of about 25 cm and contain 256 bits of on-board memory arranged in 8×32-bit blocks which may be programmed (written) and read by a suitably configured read/write device. Such tag device is useful for storing and retrieving desired user-specific information such as UPIN, UGIN, first and/or last name, age, rank or level, total points accumulated, tasks completed, facilities visited, etc. If a longer read/write range and/or more memory is desired, optional battery-powered tags may be used instead, such as available from ACXESS, Inc. and/or various other vendors known to those skilled in the art.

[0158] Another RFID tagging technology of particular interest for purposes of practicing the present invention are the so-called “chipless” RFID tags. These are extremely low-cost RFID tags that are available in the form of a printed circuit on a thin, flat adhesive. These tags are similar in size, shape and performance to the Tag-it™ inlays described above, except that these tags require no on-board integrated circuit chip. Chipless RFID tags can be electronically interrogated to reveal a pre-encoded unique ID and/or other data stored on the tag. Because the tags do not contain a microchip, they cost much less than conventional RFID tags. An adhesive-backed chipless RFID tag with up to 10 meters range and 256 bits of data, can cost one tenth of their silicon chip equivalents and typically have a greater physical performance and durability. For example, a suitable chipless RFID tag is being made available from Checkpoint Systems under its ExpressTrak™ brand. Very inexpensive chipless RFID tags (and/or other types of RFID tags) may also be directly printed on paper or foil substrates using various conductive inks and the like, such as are available from Parelec Inc. under its Parmod VLT™ brand.

[0159] In the context of carrying out an interactive gaming experience, play experience or entertainment experience, such as the type generally disclosed and described herein, such adhesive-backed tag devices and the like are highly advantageous. They are inexpensive, disposable, and may be easily secured or applied to virtually any play object, wand, wristband, badge, card or the like, for electronically storing and retrieving desired user-specific or object-specific information. Such information may include, for example, UPIN, UGIN, object type/size/shape/color, first and/or last name, age, rank or level, total points accumulated, tasks completed, facilities visited, combinations of the same or the like. For example, FIG. 20A illustrates one preferred embodiment of a wand toy **100i** having an adhesive-backed RFID tag **322** secured thereon for enabling the wand **100i** to interact with

various play effects located within an RFID-enabled play facility or play environment. FIG. 20B illustrates a second preferred embodiment of a wand toy 100j having an adhesive-backed RFID tag 322 secured thereon for enabling the wand 100j to interact with various play effects located within an RFID-enabled play facility or play environment. Similar RFID tags may also be applied to any of the other wands 100a-h disclosed and described herein or any other toys, play objects, jewelry, trinkets, action figures, collectibles, trading cards and generally any other items desired to be incorporated as part of an RFID-enabled gaming experience.

[0160] FIGS. 20E and 20F illustrate one possible preferred embodiment of a key chain trinket 321 incorporating an RFID tag 322 suitable for use in various RFID-enabled gaming and entertainment experiences as disclosed herein. Such RFID-enabled items not only make the overall gaming and entertainment experience more exciting and enjoyable, but they can create unique branding opportunities and additional lucrative revenue sources for a play facility owners/operators. Moreover, and advantageously, character attributes developed during a play a participant's visit to a local play facility are stored on the tag 322. When the play participant then revisits the same or another compatible play facility, all of the attributes of his character are "remembered" on the tag so that the play participant is able to continue playing with and developing the same role-play character. Similarly, various video games, home game consoles, and/or hand-held game units can be and preferably are configured to communicate with the tag in a similar manner as described above and/or using other well-known information storage and communication techniques. In this manner, a play participant can use the same role play character he or she has developed with specific associated attributes in a favorite video action game, role-play computer game or the like.

[0161] Trading cards incorporating RFID tags are also particularly advantageous in the context of an interactive role-playing game such as disclosed herein. For example, FIGS. 20C and 20D are front and rear views, respectively, of an optional RFID-enabled trading card 325 for use within an interactive gaming experience as described herein. For example, such RFID-enabled trading cards may be used instead of or as an adjunct to the wand 100 with RFID transponder 118 as illustrated and described above in connection with FIG. 1. Each card 325 preferably comprises a paper, cardboard or plastic substrate having a front side 328 and a back side 330. The front 328 of the card 325 may be imprinted with graphics, photos, or any other information as desired. In the particular embodiment illustrated, the front 328 contains an image of a magical wizard character 332 in keeping with an overall magic or wizard theme. In addition, the front 328 of the card may include any number of other designs or information 334 pertinent to its use and application in the game. For example, the character's special magic powers, skills and experience level may be indicated, along with any other special powers or traits the character may possess.

[0162] The obverse side 330 of the card preferably contains the card electronics comprising an RFID tag 336 pre-programmed with the pertinent information for the particular person, character or object portrayed on the front of the card. The tag 336 generally comprises a spiral wound antenna 338, a radio frequency transmitter chip 340 and various electrical leads and terminals 342 connecting the chip to the antenna. If desired, the tag may be covered with an adhesive paper label 344 or, alternatively, the tag may be molded directly into a

plastic sheet substrate from which the card is formed. Preferably, the tag 336 is passive (requires no batteries) so that it is inexpensive to purchase and maintain. The particular tag illustrated is the 13.56 MHz tag sold under the brand name Taggit™ available from Texas Instruments, Inc. (<http://www.tiris.com>, Product No. RI-103-110A). The tag may be "read/write" or "read only", depending on its particular gaming application. Optionally, less expensive chipless tags may also be used with equal efficacy.

[0163] Those skilled in the art will readily appreciate from the disclosure herein that a variety of trading card designs having features and advantages as disclosed herein may be used to play a wide variety of unique and exciting games within an RFID-enabled play facility and/or using an RFID-enabled gaming device or game console. Alternatively, persons skilled in the art will appreciate from the disclosure herein that such games may be carried out using a conventional computer gaming platform, home game console, arcade game console, hand-held game device, internet gaming device or other gaming device that includes an RFID interface. Advantageously, play participants can use trading cards 325 to transport information pertinent to a particular depicted person, character or object to a favorite computer action game, adventure game, interactive play facility or the like. For example, a suitably configured video game console and video game may be provided which reads the card information and recreates the appearance and/or traits of particular depicted person, character of object within the game. If desired, the game console may further be configured to write information to the card in order to change or update certain characteristics or traits of the character, person or object depicted by the card 325 in accordance with a predetermined game play progression.

[0164] Advantageously, RFID-enabled character trading cards and character traits, including special powers, and the like, need not be static in the game, but may change over time according to a central story or tale that unfolds in real time (e.g., through televised shows or movies released over the course of weeks, months or years). Thus, a character trading card that may be desirable for game play this week (e.g., for its special magic powers or abilities), may be less desirable next week if the underlying character is injured or captured in the most recent episode of the story. Another significant and surprising advantage of RFID-enabled trading cards is that multiple cards can be stacked and simultaneously read by a single RFID reader even where the cards are closely stacked on top of one another and even though the reader may be hidden from view. This feature and ability creates limitless additional opportunities for exciting game complexities, unique game designs and gaming strategies heretofore unknown.

[0165] FIGS. 33A-33D are front views of various alternative embodiments of possible role-play character cards for use within a Harry Potter/Hogwarts interactive play structure. See, for example, U.S. Pat. No. 6,761,637 to Weston, incorporated herein by reference, which describes an interactive play structure in the theme of a "magic" training center for would-be wizards in accordance with the popular characters and storylines of the children's book series "Harry Potter" by J. K. Rowling. Role play cards 600 are preferably constructed substantially the same as the card 325 illustrated and described above in connection with FIGS. 20C, 20D, except with different character illustrations and/or graphics. For example, each card 600 may include a different character

from a Harry Potter storyline representing a role-play character desired to be imagined by a play participant. The obverse side (not shown) includes an RFID tag, such as illustrated and described above in connection with FIG. 20D. Alternatively, a magnetic “swipe” strip and/or other well known information storage means may be used with efficacy, so long as it is relatively compact, durable and inexpensive.

[0166] The particular size, shape and theme of the cards 600 is relatively unimportant. In the particular embodiment illustrated, the cards 600 are shaped and themed so as to be used as bookmarks for Harry Potter series books. These may be packaged and sold together with each Harry Potter book, or they may be sold separately as novelty items or the like. If desired, a hole or eyelet 610 may be provided at the top of each card 600 so as to facilitate wearing the card 600 as a pendant on a necklace 620 or as key-chain trinket. Smaller, pocket-sized cards and/or other similar RFID or magnetic transponder devices may also be used where convenience and market demand dictates. Such transponder devices are commercially available, such as from Texas Instruments, Inc. (<http://www.tiris.com>, e.g., Prod. Nos. RI-TRPW9WK, RI-TRP-R9QL, RI-TRP-WFOB).

[0167] Of course, those skilled in the art will readily appreciate from the disclosure herein that the underlying concept of an RFID-enabled card 325 and card game is not limited to cards depicting fantasy characters or objects, but may be implemented in a wide variety of alternative embodiments, including conventional playing cards, poker cards, board game cards and tokens, sporting cards, educational cards and the like. If desired, any number of other suitable collectible/tradable tokens, coins, trinkets, simulated crystals or the like may also be provided and used with a similar RFID tag device for gaming or entertainment purposes in accordance with the teachings of the present invention.

[0168] For example, RFID tag devices may be included on “magic articles” that may be purchased or acquired in a gaming or interactive play system. For instance, a user may purchase an invisibility cloak, magic beads, belts, and the like during an interactive play experience. The RFID tags may be used to communicate to a central database that a certain person has purchased or is possession of the tagged item. The central database may then track the tagged items and/or may cause those in possession of the tagged items to have increased “magical” skills or powers, such as additional protection from the spells “cast” by opposing players.

[0169] RFID Readers/Writers

[0170] In accordance with another preferred embodiment of the invention various RFID readers and associated play effects are distributed throughout an entertainment facility and are able to read the RFID tags described herein and to actuate or control one or more effects in response thereto. For example, the UPIN and UGIN information can be conveniently read and provided to an associated computer, central network, display system or other tracking, recording or display device for purposes of interacting with an associated effect and/or creating a record of each play participant’s experience within the play facility. This information may be used for purposes of interactive game play, tracking and calculating individual or team scores, tracking and/or locating lost children, verifying whether or not a child is inside a facility, photo capture and retrieval, and many other useful purposes as will be readily obvious and apparent from the disclosure herein to those skilled in the art.

[0171] FIG. 21B is a simplified schematic diagram of one embodiment of an RFID reader/writer 300 for use with the wand and RFID transponder 118 of FIG. 21A. A preferred reader/writer device is the Series 2000 Micro Reader available from Texas Instruments, Inc. (<http://www.tiris.com>, e.g., Product No. RI-STU-MRD1). As illustrated, the reader/writer 300 basically comprises an RF Module 302, a Control Unit 304 and an antenna 306. When the distal end of wand 100 and its internally contained transponder 118 comes within a predetermined range of antenna 306 (about 20-200 cm) the transponder antenna 245 is excited by the radiated RF fields 308 and momentarily creates a corresponding voltage signal which powers RF transmitter/receiver chip 240. In turn, the RF transmitter/receiver chip 240 outputs an electrical signal response which causes transponder antenna 245 to broadcast certain information stored within the transponder 235 comprising, for example, 80 to 1000 bits of information stored in its internal memory. This information preferably includes a unique user ID (UPIN/UGIN), magic level or rank and/or certain other items of information pertinent to the user, the wand and/or the game or play experience.

[0172] A carrier signal embodying this information is received by antenna 306 of RFID reader/writer 300. RF Module 302 decodes the received signal and provides the decoded information to Control Unit 304. Control Unit 304 processes the information and provides it to an associated logic controller, PID controller, computer or the like using a variety of standard electrical interfaces (not shown). Thus, the information transmitted by transponder 118 and received by reader/writer 300 may be used to control one or more associated play effects through a programmable logic controller, for example. In one embodiment, the information transmitted includes data relating to the activation of the sensors 122, 124 of the wand 100. In other embodiments, the transmitted information may include timing information, such as the duration of time that a sensor is activated and/or the duration of time between successive activations of the sensors 122, 124. Play effects, may include, for example, lighting effects, sound effects, various mechanical or pneumatic actuators and the like.

[0173] Preferably, RFID reader/writer 300 is also configured to broadcast or “write” certain information back to the transponder 118 to change or update information stored in its internal memory, for example. The exchange of communications occurs very rapidly (about 70 ms) and so, from the user’s perspective, it appears to be virtually instantaneous. Thus, the wand 100 may be used to “magically” actuate and/or communicate with various associated effects by simply touching or bringing the tip of the wand 100 into relatively close proximity with the antenna 306 of a reader/writer unit 300.

[0174] As indicated above, communication of data between a tag and a reader is by wireless communication. As a result, transmitting such data is always subject to the vagaries and influences of the media or channels through which the data has to pass, including the air interface. Noise, interference and distortion are the primary sources of data corruption that may arise. Thus, those skilled in the art will recognize that a certain degree of care should be taken in the placement and orientation of readers 300 so as to minimize the probability of such data transmission errors. Preferably, the readers are placed at least 30-60 cm away from any metal objects, power lines or other potential interference sources. Those skilled in the art will also recognize that the write range of the tag/reader combination is typically somewhat less (~10-15% less) than the read range and, thus, this should also be taken

into account in determining optimal placement and positioning of each reader device **300**.

[0175] Typical RFID data communication is asynchronous or unsynchronized in nature and, thus, particular attention should be given in considering the form in which the data is to be communicated. Structuring the bit stream to accommodate these needs, such as via a channel encoding scheme, is preferred in order to provide reliable system performance. Various suitable channel encoding schemes, such as amplitude shift keying (ASK), frequency shift keying (FSK), phase shift keying (PSK) and spread spectrum modulation (SSM), are well known to those skilled in the art and will not be further discussed herein. The choice of carrier wave frequency is also important in determining data transfer rates. Generally speaking the higher the frequency the higher the data transfer or throughput rates that can be achieved. This is intimately linked to bandwidth or range available within the frequency spectrum for the communication process. Preferably, the channel bandwidth is selected to be at least twice the bit rate required for the particular game application.

[0176] FIG. 21C is a simplified circuit schematic of the reader/writer unit **300** of FIG. 21B. The read or write cycle begins with a charge (or powering phase) lasting typically 15-50 ms. During this phase, the RF Module **302** causes the antenna **306** to emit an electromagnetic field at a frequency of about 134.2 kHz. The antenna circuit is mainly formed by the resonance capacitor C1 and the antenna coil **306**. A counter-part resonant circuit of the transponder **118** is thereby energized and the induced voltage is rectified by the integrated circuit **240** and stored temporarily using a small internal capacitor (not shown).

[0177] The charge phase is followed directly by the read phase (read mode). Thus, when the transponder **118** detects the end of the charge burst, it begins transmitting its data using Frequency Shift Keying (FSK) and utilizing the energy stored in the capacitor. The typical data low bit frequency is 134.2 kHz and the typical data high bit frequency is 123.2 kHz. The low and high bits have different duration, because each bit takes 16 RF cycles to transmit. The high bit has a typical duration of 130 μ s, the low bit of 119 μ s. Regardless of the number of low and high bits, the transponder response duration is generally less than about 20 ms.

[0178] The carrier signal embodying the transmitted information is received by antenna **306** and is decoded by RF module **302**. RF Module **302** comprises integrated circuitry **312** that provides the interface between the transponder **118** and the Control Module **304** (data processing unit) of the Reader/Writer Unit **300**. It has the primary function and capability to charge up the transponder **118**, to receive the transponder response signal and to demodulate it for further digital data processing.

[0179] A Control Unit **304**, comprising microprocessor **314**, power supply **316** and RS232 Driver **318**, handles most data protocol items and the detailed fast timing functions of the Reader/Writer Module **300**. It may also operate as interface for a PC, logic controller or PLC controller for handling display and command input/output functions, for example, for operating/actuating various associated play effects.

[0180] Long Range Transmitter and Receiver

[0181] If desired, the wand **100** may also be configured for long range communications with one or more of the transceivers **300** (or other receivers) disposed within a play environment. For example, one or more transceivers **300** may be located on a roof or ceiling surface, on an inaccessible them-

ing element, or other area out of reach of play participants. Such long-range wand operation may be readily achieved using an auxiliary battery powered RF transponder, such as available from Axxess, Inc., Dallas, Tex. If line of sight or directional actuation is desired, a battery-operated infrared LED transmitter and receiver of the type employed in television remote controls may be used, as those skilled in the art will readily appreciate. Of course, a wide variety of other wireless communications devices, as well as various sound and lighting effects may also be provided, as desired.

[0182] In many of the preferred embodiments of the invention as illustrated and described herein it is disclosed to use a radio frequency (RF) and/or infrared (IR) transmitter to send wand command signals over relatively long range distances (e.g., 10-100 meters or more). For example, wand **100A** illustrated and described in connection with FIG. 7 includes an internal RF/IR Module **150** for communicating various command signals to one or more remote RF/IR receivers and associated effects. Command signal receivers may be located, for example, on a remote roof or ceiling surface of a compatible play facility, a retail mall, restaurant, destination resort facility or even an outdoor public play area. Internal RF/IR Module **150** can comprise any number of small, inexpensive RF transmitters such as are commercially available from Axxess, Inc., of Dallas, Tex. If directionality is desired, any number of small, inexpensive infrared LED transmitters may be used, such as the type commonly employed in television remote controls, keyless entry systems and the like.

[0183] FIG. 22A is a schematic block diagram of a particularly preferred transmitter module **150** adapted for use in accordance with the present invention. The transmitter module **150** generally comprises an RF transmitter **358** driven and controlled by a microprocessor or ASIC **350**. ASIC **350** includes address storage module **352**, data storage module **354** and shift register **356**. Address storage module **352** includes a stored address or coded value, for example, in parallel bit format, that is a preselected coded value that may be uniquely associated with a particular transmitter module **150**. Address storage module **352** applies the address coded value to an encoder, such as shift register **356** which, when enabled, encodes the coded value by converting it from parallel bit format to serial bit format which is applied to radio frequency (RF) transmitter **358**. Similarly, data storage module **354** may include coded data or commands provided by a user (e.g., via any of the various command input circuits and structures described above in connection with FIGS. 14-16). Data storage module **354** applies the coded data values to shift register **356** which, when enabled, encodes the coded data by converting it from parallel bit format to serial bit format which is also applied to radio frequency (RF) transmitter **358**. Radio frequency transmitter **358** modulates the coded address and data values which is encoded in serial bit format onto a radio frequency carrier signal which is transmitted as an RF output signal (RF_{Out}) such as via a simple loop antenna.

[0184] Application of electrical power from an internal battery source **152** (or one or more self-generating power sources as described herein) is preferably controlled via wand activation circuitry **115** such as illustrated and described above in connection with FIGS. 1-6. Thus, transmitter module **150**, address storage module **352**, data storage module **354**, shift register **356** and/or RF transmitter **358**, are preferably only powered for a short period of time when the wand circuitry **115** is successfully actuated and a corresponding command signal is to be transmitted. Those skilled in the art will rec-

ognize from the disclosure herein that transmitter module 150 may be implemented in a variety of known electrical technologies, such as discrete electronic circuits and/or integrated circuits. An implementation employing an integrated micro-processor or an application specific integrated circuit (ASIC) 350 is shown diagrammatically in FIG. 22A. Preferably, integrated circuitry technology and/or surface mount componentry is used to reduce the physical size of the circuit 150 such that it is able to fit within the relatively small cavity 116 of wand shaft 110 or handle 120 (see FIG. 1).

[0185] FIG. 23A is a schematic block diagram of receiver module 362 which operates in conjunction with transmitter module 150 previously described. Radio frequency command signals transmitted by transmitter module 150 are provided as input signals (RF_{in}) to RF receiver 363 which may comprise a simple tuned circuit with loop antenna (not shown). Command signals received by RF receiver 363 are applied to a decoder, such as shift register 364 which converts the coded value therein from a serial bit format to a parallel bit format. Address comparator 366 receives at one input the transmitter module coded address value in parallel bit format from shift register 364 and at its other input a preselected fixed or dynamically stored coded value from address storage 368. The preselected coded value from address storage 368 corresponds to the preselected coded value of the transmitter module 150 with which receiver module 362 is associated or compatible. In other words, the preselected coded value stored in transmitter address storage 352 of transmitter module 150 is the same as or compatible with a preselected coded value as is stored in address storage 368 of receiver module 362 with which it is associated or compatible. If the coded address value in the received command signal matches all or a predetermined portion of the preselected fixed or dynamic coded value stored in address storage 368, this coincidence is detected by address comparator 370 and is applied to restart or reset receive timer 372. Receive timer 372 preferably has a time-out period of, for example, 0.5-3 seconds and, if it is not restarted or reset within this time period, it produces a command termination signal which tells an associated controller 374 to process the received command signals(s) and to actuate one or more corresponding play effects such as lighting effects 376, sound effects 377 and motorized actuators 378. In other embodiments, the receive timer 372 may determine the type and/or intensity of the play effect based on the amount of time between command signals. For example, shorter durations of time between command signals may cause higher-intensity play effects, and longer durations of time may cause lower-intensity play effects. Each of the functional elements of receiver module 362 and controller 374 receive electrical power from a suitable power source 380, as illustrated.

[0186] In operation, a user activates circuitry 150 by appropriately waving or moving the wand. This causes electrical voltage from battery 150 to be applied across the RF transmitter module 150, thereby causing the RF transmitter module 150 to transmit a desired command signal (RF_{out}) including coded address and optional coded data information. This signal is received and decoded by receiver module 362 as input signal (RF_{in}). The decoded transmitter address information is compared to a fixed or dynamically stored coded value from address storage 368. Preferably, an immediate effect such as a pulsing light or sound is actuated by controller 374 in order to provide visual and/or aural cues that a command signal was received. Receive timer 372 is initiated and the RF receiver module 362 awaits the next command signal.

If no further signal is received before the time times out, then the spell is assumed to be complete and the controller 374 is instructed to process the received command signal(s) and actuate the appropriate relay(s) thereby triggering whatever appropriate effect(s) correspond to the spell received. Preferably, as noted above, if the spell is incomplete or is inaccurate only a "swoosh" or similar sound effect is triggered indicating that a spell was cast but did not work. For simple spells, a fixed coded value may be stored in address storage 368. For complex spells, the stored coded value may be dynamically changed to match an expected or required series or progression of command signals. Alternatively, address storage 368 may be fixed and command signals may be carried and communicated to controller 374 as decoded data corresponding to data stored in data storage module 354 (FIG. 22A).

[0187] For applications supporting multiple wands (i.e., multiple RF transmitter modules 150) within a single play space, the address comparator 366 of receiver module 362 is preferably configured to accept either: (1) a range of valid "compatible" addresses from the set of RF transmitter modules 150; or (2) any valid address from a list of valid addresses stored in address storage module 368. In the first case, each transmitter module 150 within a defined group of transmitter modules (e.g., all Level-1 wands) would preferably be configured to have a coded address value having a portion of address bits that are identical and a portion of address bits that may be unique, but unique data bits as selected by each user. The receiver module 362, upon detecting a compatible address bit sequence, decodes the data bits thereof and sets a latch selected by those particular data bits. A number of such latches, may be provided, for example, for recognizing and distinguishing further such command signals originating from multiple users and/or wands. In the second case, the receiver module 362 stores a list of specific coded values, i.e. valid addresses, in a memory, such as memory 368, and as transmitted addresses are received, they are compared to the valid addresses in this list. Thus, only signals transmitted by RF transmitter modules that are on the list of valid addresses are accepted by receiver module 362. In this manner, for example, command signals sent by Level-1 wands can be distinguished from command signals sent by Level-2 wands, which can be distinguished from Level-3 wands, etc.

[0188] Although the transmitter module 150 of FIG. 22A and the receiver module 362 of FIG. 23A are described with reference to RF technology, a skilled artisan will recognize from the disclosure herein that other types of wireless technology may also be used. For example, FIG. 22B depicts an IR transmitter module 150' having an IR transmitter 358' that may be used to transmit signals such as the type commonly employed in television remote controls, keyless entry systems and the like. The other components of the IR transmitter module 150' may also be modified such that the IR transmitter module 150' is capable of functioning similarly to the RF transmitter module 150 discussed with reference to FIG. 22A. In addition, FIG. 23B illustrates an IR receiver module 362' having an IR receiver 363' usable to operate with the IR transmitter module 150' of FIG. 22B. The other components of the IR receiver module 362' may also be modified such that the IR receiver module 363' is capable of functioning similarly to the RF receiver module 363 discussed with reference to FIG. 23A.

[0189] FIG. 24 is a schematic block diagram of a portion of a receiver module 362" including an embodiment of address comparator 370' and of address storage 368' particularly

suited for operating with a plurality of simultaneously operating transmitter modules **150** or **150'**. For example, blocks in FIG. **24** that are the same as blocks in FIG. **23A** and described above are shown in phantom and are identified by the same numeric designation as in FIG. **23A**. Address storage **368'** includes addressable registers or memory **386** in which are stored the preselected coded identification values corresponding to the preselected coded identification value of each of a plurality of compatible RF transmitter modules **150** desired to be operably associated with receiver **362''**. Address selector **388** repetitively generates a sequence of addresses including the addresses of all the registers of addressable register **386** within a relatively short time period less than about 50-100 milliseconds. Thus the complete set of preselected stored coded values are applied to one input of coded value comparator **390** whereby the received coded identification value received and decoded at the output of shift register **364** and applied to the other input of coded value comparator **390** is compared to each one of the stored coded values of the set thereof stored in addressable register **386**.

[0190] Although the receiver module **362''** of FIG. **24** is disclosed with reference to particular embodiments, a skilled artisan will recognize from the disclosure herein a wide variety of alternative structures and uses for the receiver module **362''**. For example, the receiver module **362''** may be capable of receiving an IR signal and structured similarly to the IR receiver module **362'** of FIG. **23B**.

[0191] Comparator **370'** preferably includes a latch circuit **392** having an addressable latch corresponding to each register in addressable register **386** and that is addressed by the same address value generated by address selector **388** to address register **386**. When there is a match at the inputs of coded value comparator **390** between the received coded value and the then produced stored coded value, the occurrence of the match is stored by setting the designated corresponding latch in latch circuit **392**. If received coded identification values corresponding to all of the stored fixed coded values are received and properly decoded, then all of the latches in latch circuit **392** will be set, thereby making a "true" condition at the inputs of AND gate **294** and causing its output to become "true". This "true" signal from AND gate **294** resets receive timer **372**, as described above in connection with FIG. **23A**, and also activates a reset circuit **296** to reset all the latches of latch circuit **392** so that the comparison sequence of received coded identification values to the set of stored fixed coded values begins again. If all of the preselected received coded values are not received, then all of the latches in latch circuit **392** are not set, the output of AND gate **294** does not become "true", and receive timer **372** times out and issues the command termination signal discussed above.

[0192] FIG. **25** is a detailed electrical schematic diagram of an exemplary embodiment of transmitter module **150** illustrated and discussed above. Electrical power is provided by one or more batteries **152** and/or other power sources as illustrated and described herein. This power is preferably switched by wand activation circuit **115** and/or optional timer module **402**. Electrical power is provided via diode **D2** to the transmit timer **U1**, such as an integrated circuit one-shot multivibrator type LM555 available from National Semiconductor Corporation. The time-out interval of multivibrator **U1** is established by resistors **R2**, **R3** and capacitor **C1** which need not be high precision components. When wand activation circuit **115** is activated, a voltage is applied through resistor **R1** to the gate of a transistor **Q1**. This causes electrical

power to be applied from battery **152** to a five-volt voltage regulator **U4** such as a type LM78L05 also available from National Semiconductor Corporation. Alternatively, the periodic output from **U1** may be applied to the gate of a transistor **Q1** to the same effect (e.g., for sending periodic "beacon" transmissions).

[0193] Regulated voltage from regulator **U4** is applied to shift register **356** (pin **18**) and RF transmitter **358**. Shift register **356** is implemented by an encoder integrated circuit **U2** such as a 212 series encoder type HT12E available from Holtek Microelectronics in Hsinchu, Taiwan, R.O.C. Non-volatile address storage **352** is implemented by twelve single pole switches in switch packages **SW1** and **SW2** which are set to produce a twelve-bit coded value which is applied in parallel bit format to encoder integrated circuit **U2** of shift register **356**. Once set by the manufacturer or the user, the preselected coded value stored in address storage **352** is fixed and will not change absent human intervention. However, in alternative embodiments **SW2** may be replaced in whole or in part by wand command selection circuitry such as touch switches, mercury tilt switches and the like illustrated and described above in connection with FIGS. **14-16**. Such circuitry enables users to actively select and change the coded data impressed upon address lines **8-10** of encoder integrated circuit **U2**. Integrated circuit **U2** reproduces the coded address and data values in pulse-width modulated serial-bit format and applies it through diode **D1** to RF transmitter **358**. RF transmitter **358** includes a class B biased transistor **Q2** in an L-C tuned RF oscillator transmitter coupled to a loop antenna **406** for transmitting the command signal coded values (address bits coded by **SW1** and data bits coded by **SW2**) produced by encoder **U2**.

[0194] Transmitter module **150** need only employ a small antenna such as a small loop antenna and is not required to have optimum antenna coupling. In a typical embodiment, with a transmitter frequency of about 915 MHz, a transmitter peak power output of less than or equal to one milliwatt produces a transmission range **R** of about 20-30 meters. Other frequencies and power levels may also be employed. The low transmitter power is particularly advantageous in that it allows the size of transmitter module **150** to be made very small.

[0195] FIG. **26** is an electrical schematic diagram of an exemplary embodiment of receiver module **362** illustrated and discussed above. Power is supplied by a voltage source **410** which can be either a battery or a DC power supply. Voltage from voltage source **410** is regulated by voltage regulator circuit **U3** such as type LM78L05 to produce a regulated +5 volt power supply for the functional blocks of receiver module **362**. In operation, command signals transmitted from transmitter modules are received at loop antenna **412** and applied to RF receiver **363** including a receiver sub-circuit integrated circuit **U8** such as type RX-2010 available from RF Monolithics in Dallas, Tex. The identification signal, including the twelve bit coded value in serial-bit format is coupled from the output of receiver sub-circuit **U8** to shift register decoder and address comparator **364/366** which are implemented in an integrated circuit **U5**, such as a 212 series decoder type HT12D also available from Holtek Microelectronics. Decoder **U5** converts the coded value in serial-bit format to parallel-bit format and compares that received coded value to the preselected stored coded fixed reference value in parallel bit format determined, for example, by the

positions of the twelve single pole switches in switch packages SW3, SW4 of address storage module 368.

[0196] Receive timer 372 is implemented by one-shot timer integrated circuit U6a such as type 74123N and D-flip flop U7a such as type 74HC74D, both of which are available from National Semiconductor Corporation of Santa Clara, Calif. When comparator 366 detects a match between the received coded value from transmitter module 150 and the coded value stored in address storage 368 it resets one-shot timer U6a. If one-shot timer U6a is not again reset within the time determined by timing resistor R8 and timing capacitor C9, U6a then sets flip-flop U7a and its Q output becomes low thereby applying a voltage input to controller 374 signifying the end of a transmitted simple or complex spell. Controller 374 then processes the received command signal or signals (e.g., stored in a stack register) and appropriately operates one or more associated play effects 376.

[0197] Those skilled in the art will appreciate that the switch positions of the twelve switches SW1, SW2 of transmitter module 150 correspond to the switch positions of the corresponding twelve switches SW3, SW4 of receiver module 362. These preset values may be fixed or dynamic, as discussed above. The twelve-bits available for storing coded values may be apportioned in a convenient way, for example, into an address portion and into a data portion. For example, the twelve-bit coded value can be apportioned into a ten-bit address portion (1024 possible combinations) and a two-bit data portion, which would accommodate up to four different transmitter command signals. If desired, the ten-bit address portion can be further divided into various logical portions representing, for example, the designated wand level (e.g., 1, 2, 3 or 4), special acquired magic powers or skills, experience levels and the like. This coded data would preferably be shared and coordinated between all transmitter modules 150 and receiver modules 362 such that each wand effectively would have its own unique powers and abilities as represented and identified by the coded address data. Thus, certain receivers and associated play effects would not be actuated by certain wands unless the address coding of the transmitter module thereof is coded with the appropriate matching data. In addition, the timing between received signals may be used to determine the appropriate play effect or intensity of a play effect caused by operation of the wand 100. Persons skilled in the art will recognize also that recoding of transmitter modules is a convenient way to provide for advancement of game participants within an interactive gaming experience. For example, this can be accomplished manually (e.g., by flipping dip switches SW1/SW2) or automatically/wirelessly (e.g., via RF programmable code latching circuitry, not shown).

[0198] While the foregoing embodiments have been described in terms of a radio frequency (RF) transmission between a transmitter module 150 and receiver module 362, various alternative embodiments could also readily be implemented such as, for example, replacing (or complimenting) RF transmitter and receiver set (358, 363) with an appropriately selected infrared (IR) transmitter and receiver set or a laser or light system. The IR or laser system would have particular advantage where, for example, it is desired to provide directional control of a transmitted command signal such as may be useful for directional spell casting, target practice, and wand-based shooting galleries.

[0199] Light-Activated Interactive Play System

[0200] For example, FIG. 27 illustrates an exemplary embodiment of a light-activated interactive play system 414

for use with embodiments of the invention utilizing laser technology. As shown in FIG. 27, the interactive play system 414 comprises the magic wand 100 having a light emitting module 416, a display device 418, an image preparation device 420, a camera 422, and a control system 423.

[0201] The light emitting module 416 of the wand 100 advantageously emits a directional signal, such as, for example, visible or infrared light. In one embodiment, the light emitting module 416 comprises a semiconductor laser. The signal output from the light emitting module 416 is emitted from an end opening of the wand 100 in a direction substantially parallel to the wand body. The signal may be generated from particular motions of the wand 100, as described herein, or from other input from the user.

[0202] In one embodiment, the user operates the wand 100 such that the signal emitted from the light emitting module 416 is directed to the display device 418. The display device 418 may comprise any device, apparatus or medium usable to intercept, reflect, and/or capture the signal emitted from the light emitting module 416 at an arbitrary position on the display device. In one embodiment, the display device 418 comprises a screen. In other embodiments, the display device 418 may comprise a wall, a mist, a door, a transparent surface, or the like.

[0203] Furthermore, the illustrated interactive play system 414 comprises the image preparation device 420, which operates to cause at least one image to appear on the display device 418. In one embodiment, the image preparation device 420 projects a video image and/or a still image onto the display device 418. For example, the image preparation device 420 may comprise a video projector, an LCD projector, or the like. In other embodiments, the image preparation device 420 may comprise multiple devices usable to project or to cause an image to appear on the display device 418. A skilled artisan will recognize from the disclosure herein a wide variety of objects, characters, and/or images that may be projected on the display device 418. For instance, the image preparation device 420 may project the image of mythical creatures, such as a dragon or a unicorn; magical objects, such as a flying carpet; or fantasy characters, such as a wizard or an elf; combinations of the same or the like.

[0204] In the illustrated embodiment, the display device 418 comprises a translucent material and is arranged in front of the image preparation device 420. In such an arrangement, the user's view of the image preparation device 420 may be partially or entirely obstructed by the display device 418. In other embodiments, the image preparation device 420 may be located near, to the side of, or in front of the display device 418 so long as an image may appear on the display device 418. In yet other embodiments, the image preparation device 420 is electrically coupled to the display device 418 through a wired or wireless transmission medium so as to cause images to appear on the display device.

[0205] In an embodiment, the camera 422 is directed at the display device 418 and advantageously captures, detects and/or records the arbitrary position of the signal emitted from the light emitting module 416 as the signal is intercepted by the display device 418. For example, the camera 422 may comprise a high-speed still camera or a specialized video camera used to take periodic or continuous photographs of a surface of display device 418. In an embodiment of the invention in which the light emitting module 416 outputs an infrared signal, the camera 422 is configured to record the infrared signal as it is intercepted by the display device 418. The camera 422

advantageously outputs a signal based on the captured image data to the control system 423, which captured image data includes information indicative of the position of the signal output by the light emitting module 416. In yet other embodiments, multiple cameras 422 are used in the interactive play system 414 to capture, detect, or record the position of the light emitting module signal as it is intercepted by the display device 418. For example, multiple cameras 422 may be directed at different sections of the display device 418 and/or may record or capture data from different angles.

[0206] In one embodiment, the control system 423 advantageously communicates with at least the image preparation device 420 and the camera 422. For example, the control system 423 may comprise a general purpose or a special purpose processor. However, an artisan will recognize that the control system 423 may comprise an application-specific integrated circuit (ASIC) or one or more modules configured to execute on one or more processors.

[0207] The control system 423 receives and processes the image data received from the camera 422. In one embodiment, the control system 423 analyzes the position and/or movement of the signal from the light emitting module 416 to determine modifications to be made to the subsequent images to be produced by the image preparation device 420. For example, the control system 423 may determine from the image data that a user has cast a certain “spell” by motioning the wand 100, and therefore the light emitting module 416, in a particular recognizable pattern. The control system 423 may make this determination by tracking the movement(s) of the light emitting module signal across the display device 418, which movement is recorded in the image data output from the camera 422.

[0208] For example, the control system 423 may initially command the image preparation device 420 to project an image of a brick wall onto the display device 418. The user, who sees the image of the brick wall, points his or her wand 100 toward the brick wall such that the light emitting module 416 outputs a signal, such as a red dot caused by a laser, onto the brick wall (and the display device 418). The user then motions the wand in a particular pattern, such as is described herein, to cause a desired motion of the red dot across the display device 418. The camera 422 records this movement in its image data, which is output to the control system 423 for processing. If the control system 423 determines from the image data that a certain spell has been cast, such as a “move wall” spell, the control system 423 causes the image preparation device 420 to project an image of the wall disappearing or moving out of the path or view of the user.

[0209] Although the interactive play system 414 is disclosed with reference to particular embodiments, a skilled artisan will recognize from the disclosure herein a wide variety of alternatives usable with the system 414. For example, the display device 418 may comprise a large liquid crystal display (LCD) screen coupled to an image preparation device 420 comprising a digital video source, such as a memory. Furthermore, sensors, such as optical or infrared sensors, usable to detect the position and/or movement of the light emitting module signal may be used in place of, or in combination with, the camera 422.

[0210] In yet another embodiment, the control system 423 may be in communication with a central system or database and/or various receivers capable of causing one or more play effects. Thus, the control system 423 may, in response to the signal emitted from the light emitting module 416, control or

cause play effects other than modifications to the image on the display device 418. For example, the control system 423 may command a light to turn on or a book to open based on the signal captured by the camera 422.

[0211] FIG. 27A depicts yet another embodiment of an interactive system for use with light-activation. As shown, a light-activated interactive play system 414' includes similar components as the interactive play system 414 of FIG. 27. In particular, the illustrated interactive play system 414' includes the camera 422 that advantageously captures, detects and/or records the position of a signal emitted from the light emitting module 416 of the wand 100. In one embodiment, the camera 422 is located within a substantially enclosed area, such as, for example, a room, and detects the signal emitted from the light emitting module 416 within the room and/or directed at objects or effects within the room. In other embodiments, multiple cameras 422 are located within a single room.

[0212] The camera 422 communicates with a control system 423'. Similar to the control system 423 of FIG. 27, the control system 423' receives and processes the image data received from the camera 422. For example, the control system 423' may analyze the position and/or movement of the signal from the light emitting module 416 within a room. In one embodiment, the control system 423' advantageously communicates with one or more effects, such as through wired or wireless communications, to control or trigger the effects based on the image data from the camera 422. For example, as illustrated in FIG. 27A, the interactive play system 414' includes effects such as a chair 424, a bookshelf 425 having at least one book 426, and a magic hat 427 with flowers 428.

[0213] An embodiment of a method for interactive game play will now be described with reference to FIG. 27A. A user or game participant enters a room having the interactive system 414'. The user then maneuvers his or her wand 100 such that the light emitting module 416 emits its signal in a certain direction and/or pattern, which signal is captured by the camera 422. The control system 423' then receives image data from the camera 422 that includes information relating to the position and/or movement of the signal within the room. Using this image data, the control system 423' triggers and/or controls at least one special effect.

[0214] For example, in one embodiment, if the user directs the signal from the light emitting module 416 toward the chair 424, the control system 423' causes the chair to “levitate” or to move. If the user directs the signal from the light emitting module 416 toward the bookshelf 425, the control system 423' may cause the book 426 to move or to open. If the user directs the signal from the light emitting module 416 toward the magic hat 427, the control system 423' may cause the flowers 428 to appear. Each of these described special effects may be controlled by associated effects controllers, such as motors and/or processors, that are in communication with the control system 423'. In addition, a skilled artisan will recognize from the disclosure herein a wide variety of special effects usable with the interactive system 414'. For example, the control system 423' may trigger a cuckoo clock, a light to turn on, an inanimate object to speak, and so forth.

[0215] In yet other embodiments of the invention, such as illustrated in FIG. 27B, the user performs a predetermined pattern or movement of the wand 100 to initiate a “magic spell.” The movement of the wand 100 causes a corresponding movement of the signal emitted by the light emitting module 416, which signal is captured by the camera 422. The

control system **423'** then processes the image data received from the camera **422** to determine which "spell" was cast and to cause or trigger the special effect(s) associated with the particular spell.

[0216] Competitive Games and Play Effects

[0217] It will be apparent to those skilled in the art from the disclosure herein that the invention disclosed and described herein facilitates a plethora of new and unique gaming opportunities and interactive play experiences heretofore unknown in the entertainment industry. In one embodiment the invention provides a unique play experience that may be carried out within a compatible play facility, retail space and/or other facility utilizing a wand as disclosed and described herein. With a wand or other similarly enabled device, play participants can electronically and "magically" interact with their surrounding play environment(s) to produce desired play effect, thereby fulfilling play participants' fantasies of practicing, performing and mastering "real" magic.

[0218] For example, FIG. **28** illustrates one preferred embodiment of a wand-actuated play effect comprising a player piano **429** that is adapted to be responsive to or controlled by an RF command signal transmitted by magic wand toy **100**. Those skilled in the art will readily appreciate that an RF receiver and associated controller, such as disclosed and described herein, can easily be concealed within the piano **429** and/or in the vicinity thereof such that it electronically interfaces with and directs various selected control circuitry associated with the piano **429**. These may include, for example, circuitry for controlling: power on/off, song selection, playing speed and volume, instrument selection and special sound effects, sound sampling, combinations of the same or the like. In operation, user **430** would wave the wand **100** in accordance with one or more specific learned motions selected by the user to achieve a desired effect (e.g., piano on/off, play next song, speed-up/slow down, change piano sound, combinations of the same or the like). Most preferably, the wand **100** contains internal activation circuitry, such as described herein, such that the wand may be activated by the motion induced thereon by a user and so that actuation and control of the special effect appears to be, and has the feeling to user **430** of being, created by "real" magic.

[0219] FIG. **29** illustrates another preferred embodiment of a wand-actuated play effect comprising magical or "enchanted" bookshelves **436**. The bookshelves contain multiple shelves of simulated or real books **438** that are controlled by one or more concealed actuators. The actuators are preferably positioned and arranged such that, when actuated, they cause one or more selected books to move, vibrate or levitate. Again, those skilled in the art will readily appreciate that an RF receiver and/or associated controller, such as disclosed and described herein, can easily be concealed within the bookshelves **436** and/or in the vicinity thereof. Movement and vibration of selected books can be provided, for example, by various linear stepper-motor actuators associated with one or more of the books **438**. Each actuator may be controlled, for example, by a magnetic reed switch closure hidden behind the binder of each book. As a user **430** lightly touches the binder of each book with a magnetically-tipped wand **100** the associated reed switch (not shown) is closed, connecting power to an associated vibrator/actuator. Then, as the user **430** waves the wand **100** in one or more particular ways the selected book appears to vibrate or move as if it is being lifted or controlled by the magic wand **100**. More spectacular effects may include, for example: (i) an effect that causes all

or some of the books **438** to vibrate or move violently, randomly and/or in a rhythmic pattern (e.g., as if dancing); (ii) an effect that causes one or more books to appear as if floating or levitating; (iii) an effect that causes all or some of the books to magically rearrange themselves; (iv) an effect that causes one or more selected books to talk or tell stories; and (v) an effect that causes two or more books to appear to have a quarrel, argument or debate (e.g., about an interesting historical fact or event). Some or all of these larger, more spectacular effects may be, and preferably are, restricted to only users **430** who possess and have learned to use, for example, a Level-3 wand or above. Thus, for example, a goal-oriented or object-driven, interactive game may be provided wherein play participants compete with one another to learn and master certain game tasks in order to achieve successively more challenging goals or objectives and to thereby earn additional powers, spells, abilities, points, special recognition and/or other rewards within the context of an overall game experience. Preferably, in each case and regardless of the level of wand used, actuation and control of the special effect appears to be, and has the feeling to user **430** of being, created by "real" magic. Of course, many other possible fun and/or exciting special effects will be readily apparent and obvious from the disclosure herein to persons skilled in the art.

[0220] FIG. **30** illustrates another preferred embodiment of a wand-actuated play effect comprising a water fountain **440** having one or more associated water features **442** responsive to or controlled by an RF command signal transmitted by one or more wands **100**. An RF receiver and associated controller, such as disclosed and described herein, can easily be placed within an associated fountain control system or panel, electronically interfacing therewith to direct or control various selected fountain features or functions. These may include, for example, on/off control of water flow, fountain lighting, special water features **442**, combinations of the same or the like. In operation, one or more users **430** would wave their wands **100** in accordance with one or more specific learned motions selected by each user to achieve a desired effect (e.g., fountain on, next water feature, increase/decrease water feature, change lighting intensity/color, or the like). Most preferably, each wand **100** contains internal activation circuitry, such as described herein, such that each wand may be activated by the motion induced thereon by each user and so that actuation and control of the special effect appears to be, and has the feeling to users **430** of being, created by "real" magic.

[0221] FIGS. **31A** and **31B** are time-lapsed schematic illustrations of a preferred embodiment of a play facility or play center constructed in accordance with the present invention. The play facility may comprise a family entertainment center, retail entertainment space, arcade, theme park, destination resort, restaurant, or the like, themed as a magic training center or any variety of other suitable themes as may be desired. The play facility preferably comprises multiple wand-actuated play effects **400**, such as talking animals **452**, magic hats **454**, crystal balls **456**, enchanted books **458**, and various shooting-gallery-style pop-up target effects **460**, **462**. These may be physical play objects configured with special effects, as illustrated, and/or they may be graphical or computer-generated images displayed, for example, on one or more associated computer monitors, TV monitors, DVD display monitors, or computer gaming consoles and the like, such as illustrated in FIG. **27B**. Those skilled in the art will readily appreciate from the disclosure herein that all of these effects and many other possible play effects may be actuated

or controlled by wand **100** using one or more RF receivers, RFID reader/writers and/or magnetic reed switches, as disclosed and described above.

[0222] Some interactive play effects **400** may have simple or immediate consequences, while others may have complex and/or delayed consequences and/or possible interactions with other effects. Some play effects **400** may local (short range) while other effects may be remote (long range). Each play participant **430**, or sometimes a group of play participants working together, preferably must experiment with the various play effects using their magic wands **100** in order to discover and learn how to create one or more desired effect(s). Once one play participant figures it out, he or she can use the resulting play effect to surprise and entertain other play participants. Yet other play participants will observe the activity and will attempt to also figure it out in order to turn the tables on the next group. Repeated play on a particular play element can increase the participants' skills in accurately using the wand **100** to produce desired effects or increasing the size or range of such effects.

[0223] Most preferably, a live-action object-oriented or goal-oriented, interactive game is provided whereby play participants compete with one another (and/or against themselves) within a compatible play space to learn and master certain play effects and game tasks in order to achieve successively more challenging goals or game objectives and to thereby earn additional powers, spells, abilities, points, special recognition and/or other rewards within the context of an overall game experience. For example, play participants can compete with one another to see which participant or group of participants can create bigger, longer, more accurate or more spectacular effects. Other goals and game objectives may be weaved into an entertaining story, such as a magical quest or treasure hunt in which play participants immersed. The first task may be to build a magic wand. The next task may be to learn to use the magic wand to locate and open a secret treasure box filled with magical secrets (e.g., various spell formulas or magical powers). The ultimate goal may be to find and transform a particular frog (identified by, e.g., secret markings or other secret characteristics) into a prince/princess. Of course, many other gaming and theming possibilities are possible and desirable. Optionally, various "take home" play effects can also be provided for the purpose of allowing play participants to continue the magical experience (and practice their skills) at home.

[0224] In one preferred embodiment, a user **430** would preferably point and/or wave the wand **100** in accordance with one or more specific learned motions or "spells" selected to achieve a desired effect on one or more selected objects. For example, as illustrated in FIG. **31B**, one spell may cause rabbit **452** to talk; another spell may cause hat **454** to magically sprout flowers **464**; another spell may cause book **458** to open with a frog **466** jumping out; another spell may cause an image of a wizard **468** to magically appear (with optional sound and lighting effects) within crystal ball **456**; another spell may cause candle **462** to magically light itself with a pop-up flame **470**. Most preferably, wand **100** contains internal activation circuitry, such as described herein, such that the wand may be activated by the motion induced thereon by user **430** and so that actuation and control of the special effect appears to be, and has the feeling to users **430** of being, created by "real" magic. To provide added mystery and fun, certain effects **400** may be hidden such that they must be

discovered by play participants. If desired, various clues can be provided such as, for example, part of a magical mystery game.

[0225] In each of the play effects described above, it is possible, and in many cases desirable, to provide additional control interlocks so that multiple input signals are required to actuate a given desired effect. For example, a proximity sensor may be provided associated with a given effect and electronically interlocked with the effect controller such that the effect cannot be operated if the proximity sensor is not also actuated. This could help reduce inadvertent or random actuation of the various effects. Similarly, voice activated controls and voice recognition software could also be implemented and interlocked with the effect controller so that, for example, a user **430** would need to say a particular "magic" word or phrase while waving the magic wand **100** in order to actuate a desired effect.

[0226] As mentioned, the proximity sensor may be used to provide a "hover" effect that is indicative of the initialization of a control interlock. For example, when a proximity sensor in the wand **100** is moved within a particular distance of a receiver and/or effects controller, a "hover" effect occurs, such as, for example, the turning on of a light, the movement or vibration of an object, or any other perceptible signal (visual or audible) that notifies the user that a play effect may be initiated. This "hover" effect may notify the user that a spell may be cast so as to cause one or more effects.

[0227] Most preferably, a live-action object-oriented or goal-oriented, interactive game is provided whereby play participants compete with one another (and/or against themselves) within a compatible play space to learn and master certain play effects and game tasks in order to achieve successively more challenging goals or game objectives and to thereby earn additional powers, spells, abilities, points, special recognition and/or other rewards within the context of an overall game experience. For example, play participants can compete with one another to see which participant or group of participants can create bigger, longer, more accurate or more spectacular effects. Other goals and game objectives may be weaved into an entertaining story, such as a magical quest or treasure hunt in which play participants immersed. The first task may be to build a magic wand. The next task may be to learn to use the magic wand to locate an open a secret treasure box filled with magical secrets (e.g., various spell formulas or magical powers). The ultimate goal may be to find and transform a particular frog (identified by, e.g., secret markings or other secret characteristics) into a prince/princess. Of course, many other gaming and theming possibilities are possible and desirable. Optionally, various "take home" play effects can also be provided for the purpose of allowing play participants to continue the magical experience (and practice their skills) at home.

[0228] FIGS. **32A-D** illustrate one preferred embodiment of a wand-actuated game **500** having unique features and benefits in accordance with the present invention. The game **500** basically comprises a 3x7 grid of lighted squares (including optional visual graphics and/or sound effects) that are controlled by a game effects controller (not shown) and one or more RF receivers (not shown). Those skilled in the art will readily appreciate and understand from the disclosure herein how to set up and program a game controller and/or one or more RF receivers as disclosed and described herein so as to achieve the game functionality and various effects as will be described herein below. Preferably, one RF receiver (or IR

receiver, RFID receiver, or the like) is provided for each play participant **430** so that command signals from each player can be distinguished. For example, multiple RF receivers may be directionally focused or range-adjusted so as to receive RF command signals only from a selected corresponding player **430a** or **430b**.

[0229] Individual squares within a defined playing field **504** are preferably lit or dimmed in a timed sequence in response to one or more predetermined RF command signals (“spells”) received from one or more RF-enabled wands **100**. Preferably, special 3×1 arrays of squares **510a**, **510b** (labeled **1-2-3**) are provided at opposite ends of a playing field **504** and are adapted to respond to a signal imposed by, for example, the presence, proximity or weight of play participants **430a**, **430b**, as they stand on each square. These special squares may be raised or otherwise differentiated, as desired, to indicate their special function within the game **500**. Actuating individual squares within arrays **510a** and **510b** (e.g., by stepping or standing on them) allows play participants **430a**, **430b** to select a corresponding column of squares in the playing field **504** in which they may desire to launch an attack, counterattack or defense using various learned spells or incantations. Spells may be actuated, for example, by waving wand **100** in one or more particular learned motions selected to produce a desired play effect or spell. An infinite variety of such spells are possible as described above.

[0230] Preferably, when a spell is successfully cast by a player **430a** or **430b**, the first square immediately in front of the player lights up or is otherwise controlled to produce a special effect indicating that a spell has been cast. Other squares in the same column are then preferably lit in a timed sequence or progression moving toward the opposing player (see, e.g., FIGS. **32B** and **32C**). Most preferably, the lighting effects for each square and/or other associated special effects are controlled or varied in a way to indicate the type of spell cast (e.g., a fire ball spell, ice spell, transforming spell, or the like). For example, various colors or patterns of lights may be used to indicate each spell. Alternatively, various graphic images and/or associated sound effects may be used to indicate each spell. These may be displayed, for example, on an overhead TV or associated computer monitor (not shown).

[0231] When an opposing player perceives that a spell has been cast and is moving toward him, that player (e.g., player **430b** in FIG. **32B**) attempts to quickly identify the type of spell and to cast in the same column a counter-measure or “blocking spell” in an attempt to neutralize or block the advancing spell (see, e.g., FIG. **32C**). The blocking spell may be cast, for example, using the same particular wand motion or series of wand motions used to cast the “forward spell”, except with a “block” command added. Thus, a blocking spell is launched toward the advancing spell, as indicated by a progression of lighted squares and/or other effects controlled in a similar fashion as described above. If the blocking spell is effective (i.e., properly selected and executed), then the advancing spell is neutralized and the lighted column of squares is cleared (see, e.g., FIGS. **32C** and **32D**). If the blocking spell is ineffective, then the advancing spell continues until it reaches the end of the column. Preferably, whenever a spell reaches the opposing side, points and/or other gaming advancements are awarded to the successful player. These may vary, for example, depending upon the difficulty level of the spell, the experience level of the opposing player, and the like. In one particularly preferred embodiment, successful players are rewarded (and unsuccessful players are

punished) by allowing certain spells to “capture” or disable the opposing player’s special square in each corresponding column (see., e.g., FIG. **32D**). Once all of a player’s special squares **510a**, **510b** have been captured or disabled the game is ended.

[0232] Preferably, the speed of game play progresses and becomes faster and faster as game play continues (e.g., spells move faster). In this manner, the game **500** continually challenges game participants to improve their reaction speed and spell accuracy. The game also encourages players to learn and master more difficult or complex spells, as these will be typically be harder and take longer for an opponent to successfully block. Certain additional spells or advanced commands may also be provided for speeding up a spell or slowing down an advancing spell. Any infinite variety and possibility of other spells and game play nuances are possible and desirable in accordance with the fundamental aspects of the invention disclosed and described herein.

[0233] Those skilled in the art will also recognize from the disclosure herein that the game **500** is not limited to use with RF-enabled input devices, such as wands, cards, tokens and the like, as described herein. Alternatively, the game **500** may be readily adapted and used with a wide variety of other input devices, including, without limitation, RFID tracking, magnetic actuators, joysticks, push-buttons, computer mouse or keypad, foot pedals, motion sensors, virtual-reality gloves and the like, proximity sensors, weight sensors, or the like. Similarly, the game **500** is not limited to use with a magic theme, but may be implemented in a wide variety of other suitable themes such as, without limitation, war games, martial arts, “shoot-out” games, alien invasion, memory games, board games, educational games, trivia games, strategy games, and the like. It is also specifically contemplated that the game **500** may be expanded or modified to accommodate 3 or more players. For example, a six-sided game field accommodating up to six different players may easily be implemented using a similar playing field made up of hexagonal “squares”.

[0234] Master System

[0235] In addition, a skilled artisan will recognize from the disclosure herein that the foregoing competitive games and/or play effects may use a central or master system to coordinate, control, and/or monitor the status of the games or effects in a particular area. For example, a central database may be used to monitor the skill levels of all those who are participating in the competitive game in a particular location. In other embodiments, the central system may comprise a centralized computer network that monitors the operation of each wand **100** (e.g., the play effects caused by operation of the wand) within a particular area. In yet other embodiments, the wands **100** may automatically download information from the central system.

[0236] If a master system is utilized, preferably each wand **100** and/or RFID card **325** is configured to electronically send and receive information to and from various receivers or transceivers **300** distributed throughout a play environment using a send receive radio frequency (“SRRF”) communication protocol. This communications protocol provides the basic foundation for a complex, interactive entertainment system which creates a seemingly magic interactive play experience for play participants who possess and learn to use the magic wand. In its most refined embodiments, a user may electronically send and receive information to and from other wands and/or to and from a master control system located

within and/or associated with any of a number of play environments, such as a family entertainment facility, restaurant play structure, television/video/radio programs, computer software program, game console, web site, etc. This newly created network of SRRF-compatible play and entertainment environments provides a complex, interactive play and entertainment system that creates a seamless magical interactive play experience that transcends conventional physical and temporal boundaries.

[0237] SRRF may generally be described as an RF-based communications technology and protocol that allows pertinent information and messages to be sent and received to and from two or more SRRF compatible devices or systems. While the specific embodiments described herein are specific to RF-based communication systems, those skilled in the art will readily appreciate that the broader interactive play concepts taught herein may be realized using any number of commercially available 2-way and/or 1-way medium range wireless communication devices and communication protocols such as, without limitation, infrared-, digital-, analog, AM/FM-, laser-, visual-, audio-, and/or ultrasonic-based systems, as desired or expedient.

[0238] The SRRF system can preferably send and receive signals (up to 40 feet) between tokens and fixed transceivers. The system is preferably able to associate a token with a particular zone as defined by a token activation area approximately 10-15 feet in diameter. Different transceiver and antenna configurations can be utilized depending on the SRRF requirements for each play station. The SRRF facility tokens and transceivers are networked throughout a play environment. These devices can be hidden in or integrated into the environmental infrastructure, such as walls, floors, ceilings and play station equipment. Therefore, the size and packaging of these transceivers is not particularly critical.

[0239] In a preferred embodiment, an entire entertainment facility may be configured with SRRF technology to provide a master control system for an interactive entertainment play environment using SRRF-compatible magic wands and/or tracking devices. A typical entertainment facility provided with SRRF technology may allow 300-400 or more users to more-or-less simultaneously send and receive electronic transmissions to and from the master control system using a magic wand or other SRRF-compatible tracking device.

[0240] In particular, the SRRF system uses a software program and data-base that can track the locations and activities of up to a hundred or more users. This information is then used to adjust the play experience for each user based on “knowing” where the user/player has been, what objectives that player has accomplished and how many points or levels have been reached. The system can then send messages to the user throughout the play experience. For example, the system can allow or deny access to a user into a new play area based on how many points or levels have been reached by that user and/or based on what objectives that user has accomplished or helped accomplish. It can also indicate, via sending a message to the user the amount of points or specific play objectives necessary to complete a “mission” or enter the next level of play. The master control system can also send messages to the user from other users.

[0241] The system is preferably sophisticated enough that it can allow multiple users to interact with each other adjusting the game instantly. The master system can also preferably interface with digital imaging and/or video capture so that the users activities can be visually tracked. Any user can locate

another user either through the video capturing system or by sending a message to another device. At the end of a visit, users are informed of their activities and the system interfaces with printout capabilities. The SRRF system is preferably capable of sending and receiving signals up to 100 feet. Transmitter devices can also be hidden in walls or other structures in order to provide additional interactivity and excitement for play participants.

[0242] Suitable embodiments of the SRRF technology described above may be obtained from a number of suitable sources, such as AXCESS, Inc. and, in particular, the AXCESS active RFID network system for asset and people tracking applications. In another preferred embodiment the system comprises a network of transceivers **300** installed at specific points throughout a facility. Players are outfitted or provided with a reusable “token”-a standard AXCESS personnel tag clipped to their clothing in the upper chest area. As each player enters a specific interactive play area or “game zone” within the facility, the player’s token receives a low frequency activation signal containing a zone identification number (ZID). The token then responds to this signal by transmitting both its unique token identification number (TID) along with the ZID, thus identifying and associating the player with a particular zone.

[0243] The token’s transmitted signal is received by a transceiver **300** attached to a data network built into the facility. Using the data network, the transceiver forwards the TID/ZID data to a host computer system. The host system uses the SRRF information to log/track the guest’s progress through the facility while interfacing with other interactive systems within the venue. For example, upon receipt of a TID/ZID message received from Zone 1, the host system may trigger a digital camera focused on that area, thus capturing a digital image of the player which can now be associated with both their TID and the ZID at a specific time. In this manner the SRRF technology allows the master control system to uniquely identify and track people as they interact with various games and activities in a semi-controlled play environment. Optionally, the system may be configured for two-way messaging to enable more complex interactive gaming concepts.

[0244] In another embodiment, the SRRF technology can be used in the home. For enabling magic at the home, a small SRRF module is preferably incorporated into one or more portable toys or objects that may be as small as a beeper. The SRRF module supports two-way communications with a small home transceiver, as well as with other SRRF objects. For example, a magic wand **100** can communicate with another magic wand **100**.

[0245] The toy or object may also include the ability to produce light, vibration or other sound effects based on signals received through the SRRF module to complement the operation of the wand and/or the effects achieved. In a more advanced implementation, the magical object may be configured such that it is able to display preprogrammed messages of up to 50 characters or more on a LCD screen when triggered by user action (e.g. button) or via signals received through the SRRF module. This device is also preferably capable of displaying short text messages transmitted over the SRRF wireless link from another SRRF-compatible device. For example, FIG. 19G shows a toy wand **100** having an LCD screen **113** for displaying short text messages.

[0246] Preferably, the SRRF transceiver **300** is capable of supporting medium-to-long range (10-40 feet) two-way com-

munications between SRRF objects and a host system, such as a PC running SRRF-compatible software. This transceiver **300** has an integral antenna and interfaces to the host computer through a dedicated communication port using industry standard RS232 serial communications. It is also desirable that the SRRF transmission method be flexible such that it can be embedded in television or radio signals, videotapes, DVDs, video games and other programs media, stripped out and re-transmitted using low cost components. The exact method for transposing these signals, as well as the explicit interface between the home transceiver and common consumer electronics (i.e. TVs, radios, VCRs, DVD players, A/V receivers, etc.) is not particularly important, so long as the basic functionality as described above is achieved. The various components needed to assemble such an SRRF system suitable for use with the present invention are commercially available and their assembly to achieve the desired functionality described above can be readily determined by persons of ordinary skill in the art. If desired, each SRRF transceiver may also incorporate a global positioning (“GPS”) device to track the exact location of each play participant within one or more play environments.

[0247] Most desirably, a SRRF module can be provided in “chip” form to be incorporated with other electronics, or designed as a packaged module suitable for the consumer market. If desired, the antenna can be embedded in the module, or integrated into the toy and attached to the module. Different modules and antennas may be required depending on the function, intelligence and interfaces required for different devices. A consumer grade rechargeable or user replaceable battery may also be used to power both the SRRF module and associated toy electronics.

[0248] Interactive Game Play

[0249] Embodiments of the present invention may be carried out using a wide variety of suitable game play environments, storylines and characters, as will be readily apparent to those skilled in the art. The following specific game play examples are provided for purposes of illustration and for better understanding of the invention and should not be taken as limiting the invention in any way:

Example 1

[0250] An overall interactive gaming experience and entertainment system is provided (called the “Magic” experience), which tells a fantastic story that engages children and families in a never-ending adventure based on a mysterious treasure box filled with magical objects. Through a number of entertainment venues such as entertainment facilities, computer games, television, publications, web sites, and the like, children learn about and/or are trained to use these magical objects to become powerful “wizards” within one or more defined “Magic” play environments. The play environments may be physically represented, such as via an actual existing play structure or family entertainment center, and/or it may be visually/aurally represented via computer animation, television radio and/or other entertainment venue or source.

[0251] The magical objects use the SRRF communications system allowing for messages and information to be received and sent to and from any other object or system. Optionally, these may be programmed and linked to the master SRRF system. Most preferably, the “magic wand” **100** is configured to receive messages from any computer software, game console, web site, and entertainment facility, television program that carries the SRRF system. In addition, the magic wand can

also preferably send messages to any SRRF compatible system thus allowing for the “wand” to be tracked and used within each play environment where the wand is presented. The toy or wand **100** also preferably enables the user to interact with either a Master system located within a Magic entertainment facility and/or a home-based system using common consumer electronic devices such as a personal computer, VCR or video game system.

[0252] The master control system for a Magic entertainment facility generally comprises: (1) a “token” (gag, toy, wand **100** or other device) carried by the user **430**, (2) a plurality of receivers or transceivers **300** installed throughout the facility, (3) a standard LAN communications system (optional), and (4) a master computer system interfaced to the transceiver network (optional). If a Master computer system is used, preferably the software program running on the Master computer is capable of tracking the total experience for hundreds of users substantially in real time. The information is used to adjust the play for each user based on knowing the age of the user, where the user has played or is playing, points accumulated, levels reached and specific objectives accomplished. Based on real-time information obtained from the network, the system can also send messages to the user as they interact throughout the Magic experience.

[0253] The Master system can quickly authorize user access to a new play station area or “zone” based on points or levels reached. It can also preferably indicate, via sending a message to the user, the points needed or play activities necessary to complete a “mission.” The Master system can also send messages to the user from other users. The system is preferably sophisticated enough to allow multiple users to interact with each other while enjoying the game in real-time.

[0254] Optionally, the Master system can interface with digital imaging and video capture so that the users’ activities can be visually tracked. Any user can then locate another user either through the video capturing system or by sending a message to another device. At the end of a visit, users are informed of their activities and other attributes related to the Magic experience via display or printout.

[0255] For relatively simple interactive games, the Master system may be omitted in order to save costs. In that case, any game-related information required to be shared with other receivers or transceivers may be communicated via an RS-232 hub network, Ethernet, or wireless network, or such information may be stored on the wand itself and/or an associated RFID card or badge carried by the play participant. For retrofit applications, it is strongly preferred to provide substantially all stand-alone receivers or transceivers that do not communicate to a master system or network. This is to avoid the expense of re-wiring existing infrastructure. For these applications, any information required to be shared by the game system is preferably stored on the wand or other RFID device(s) carried by the play participants. Alternatively, if a more complex game experience is demanded, any number of commercially available wireless networks may be provided without requiring rewiring of existing infrastructure.

Example 2

[0256] A computer adventure game is provided in which one or more play participants assume the role of an imaginary character “Pajama Sam” from the popular series of computer games published by Humongous Entertainment, Inc. of Woodinville, Wash. A Pajama Sam adventure character card **700**, such as illustrated in FIGS. **34A**, **34B**, is provided to each

play participant. The card may be packaged and sold together with the game software, and/or it may be sold separately, as convenience and market demands dictate.

[0257] The card 700 may be constructed substantially the same as the cards 325, 600 illustrated and described above in connection with FIGS. 20C-D and 33, except with different character illustrations and/or graphics. For example, each card 700 may include a different character from the Pajama Sam computer game series representing a role-play character desired to be imagined by a play participant. The obverse side (FIG. 34B) includes an RFID tag 720, such as illustrated and described above in connection with FIG. 20D. Preferably, the tag 720 is covered with an adhesive paper label 725. Alternatively, the tag 720 may be molded directly into a plastic sheet substrate from which the card 700 is then formed. Alternatively, a magnetic “swipe” strip and/or other well-known information storage means may be used with efficacy, so long as it is relatively compact, durable and inexpensive.

[0258] The particular size, shape and theme of the card 700 is relatively unimportant. In the particular embodiment illustrated, the card 700 is shaped and themed similar to a baseball trading card so that they may be collected and stored conveniently in any baseball card album or the like. If desired, a hole or eyelet (not shown) may be provided at the top of the card 700 so as to facilitate wearing the card 700 as a pendant on a necklace or as key-chain trinket. Of course, smaller, pocket-sized cards and/or other similar RFID or magnetic transponder devices may also be used where convenience and market demand dictates. Such alternative suitable transponder devices are commercially available, such as from Texas Instruments, Inc. (<http://www.tiris.com>, e.g., Prod. Nos. RI-TRP-W9WK, RI-TRP-R9QL, RI-TRP-WFOB).

[0259] A specially configured computer, video game, home game console, hand-held gaming device or similar gaming device is provided with a reader, and more preferably a reader/writer such as described above, that is able to communicate with the tag 720 or other information storage means associated with the card 700. As each play participant plays his or her favorite Pajama Sam game the Pajama Sam character represented by the card 700 gains (or loses) certain attributes, such as speed, dexterity, and/or the possession of certain tools or objects associated with the game play. All of this information is preferably stored on the card 700 so that the character attributes may be easily and conveniently transported to other similarly-equipped computer games, video games, home game consoles, hand-held game units, play facilities, and the like. In this manner, an imaginary role-play character is created and stored on a card that is able to seamlessly transcend from one play medium to the next.

[0260] For example, in the course of playing a typical Pajama Sam game, players must “find” certain objects or tools that they will use to solve certain puzzles or tasks presented by the game. Players “pick up” these objects or tools by clicking their mouse on the desired object. The computer game software then keeps a record of which objects have been collected and displays those objects on the computer screen when requested by the player. This is illustrated by FIG. 35A, which is a screen shot from the computer game, “Pajama Sam, in No Need to Hide When It’s Dark Outside,” published by Humongous Entertainment, Inc. © 1996. The game begins in Pajama Sam’s bedroom, and the player is asked to find and click on certain objects 810 that Pajama Sam needs to begin his adventure—namely his flashlight, PajamaMan lunch box and PajamaMan mask. As these objects are located and col-

lected, they are displayed on the bottom of the computer screen, as illustrated in FIG. 35A.

[0261] FIG. 35B is a screen shot from the same game where the player faces his first challenge or puzzle to solve. He or she must somehow make Pajama Sam operate the elevator 815 to take Pajama Sam up into the tree house 820 where his archenemy “Darkness” resides. To solve the puzzle the player explores the scene with his mouse and clicks on objects that might be useful to solve the puzzle. Eventually, the player will discover a pile of rocks 825 which Pajama Sam picks up and tosses into the basket 830 to operate the elevator. In the next scene (FIG. 35E) Pajama Sam is inside the tree house and the player must decide which of three possible paths to take representing doors 840, 845 and 850. Doorway 850 leads to the scene illustrated in FIG. 35D in which Pajama Sam (and the player) is challenged to a trivia game by a pair of talking doors. The player chooses from different categories of questions and attempts to choose correct answers from a multiple choice list provided by the game (see FIG. 35E). Ultimately, the player is challenged with a question specific to the game (see FIG. 35F) and which requires the player to have visited a particular location within the game where the information is contained. If the player has not completed that portion of the computer game, he or she cannot answer the question posed and Pajama Sam cannot advance in the adventure game (see FIG. 35G).

[0262] If the player were to quit the game at this point, he or she could save the game on the host computer and return to the same computer later to complete the adventure. But the Pajama Sam character itself, its attributes, experiences and accomplishments are not portable and cannot presently be transferred from one game or gaming environment to another. However, the Pajama Sam adventure card 700 in accordance with the present invention enables a play participant to continue the adventure somewhere else (e.g. at a friend’s house, or a video arcade facility) without having to restart the game and repeat the steps that the player has already accomplished. With the Pajama Sam adventure card 700, relevant details of the game experience and the Pajama Sam character are stored on the card 700 so that the player can take the card to another computer, game console, hand-held game device or a designated Pajama Sam play facility, to continue the adventure in a new and exciting play environment.

[0263] For example, the Pajama Sam play facility could be configured as a physical play space having theming and game play that parallels that of one or more of the Pajama Sam computer adventure games. Now our computer game player who has a Pajama Sam adventure card 700 can visit this play facility and the facility would be able to read the information on the card and determine that this particular player has already completed the first puzzle in the first Pajama Sam computer adventure game. If the player desires, he or she will be allowed to advance automatically in the game play within the Pajama Sam play facility so that the player can work on a new puzzle. If the player successfully solves a new puzzle at the play facility, this information will be recorded on the Pajama Sam adventure card 700. The next time he or she plays the computer game the card can be automatically read and the computer experience can be modified or updated in accordance with the new information recorded on the card. In this manner, the character role-play experience becomes portable, personal and long-term. This, in turn, facilitates the development of even more sophisticated and complex role-play characters and longer, more enjoyable role play experiences as

players are able to continue playing with and developing the same role-play character(s) over long periods of time and in different and varied play environments.

[0264] Similarly, various other video games, home game consoles, and/or hand-held game units can be and preferably are configured to communicate with the Pajama Sam adventure card **700** in a similar manner as described above and/or using other well-known information storage and communication techniques. In this manner, a play participant can use the Pajama Sam adventure card **700** and the role play character he or she has developed with specific associated attributes in a favorite video action game, role-play computer game, internet adventure game or the like.

Example 3

[0265] A trading card game is provided wherein a plurality of cards depicting various real or imaginary persons, characters and/or objects are provided and wherein each card has recorded or stored thereon in an electronically readable format certain selected information pertaining to the particular person, character or object, such as performance statistics, traits/powers, or special abilities. The information is preferably stored on an RFID tracking tag associated with each card and which can be read electronically and wirelessly over a predetermined range preferably greater than about 1 cm when placed in the proximity of a suitably configured RF reader. Optionally, the RFID tag may be read/write capable such that it the information stored thereon may be changed or updated in any manner desired. Alternatively, a magnetic strip, bar code or similar information storage means may be used to store relevant information on the card.

[0266] FIGS. **36A** and **36B** depict one preferred embodiment of a trading card **900** having features and advantages in accordance with the present invention. The particular trading card illustrated in FIG. **36A** is provided in the theme of the popular Pokemon characters and, in particular, the character Pikachu. FIGS. **36C** and **36D** illustrate several other possible Pokemon themed trading cards which may be provided in accordance with the present invention. Each card preferably comprises a paper, cardboard or plastic substrate having a front side **905** and a back side **910**. The front **905** of the card **900** may be imprinted with graphics, photos, or any other information as desired. In the particular embodiment illustrated, the front **905** contains an image of the Pikachu character **925** in keeping with the Pokemon theme. In addition, the front **905** of the card **900** may include any number of other designs or information **930** pertinent to its application. For example, the character's type, size and evolution may be indicated, along with any special powers or traits the character may possess.

[0267] The obverse side **910** of the card **900** preferably contains the card electronics comprising a radio frequency tag **920** pre-programmed with the pertinent information for the particular person, character or object portrayed on the front of the card. The tag **920** generally comprises a spiral wound antenna **950**, a radio frequency transmitter chip **960** and various electrical leads and terminals **970** connecting the chip **960** to the antenna. If desired, the tag **920** may be covered with an adhesive paper label (not shown) or, alternatively, the tag may be molded directly into a plastic sheet substrate from which the card **900** is formed.

[0268] Preferably, the tag **920** is passive (requires no batteries) so that it is inexpensive to purchase and maintain. Such tags and various associated readers and other accessories are

commercially available in a wide variety of configurations, sizes and read ranges. RFID tags having a read range of between about 10 cm to about 100 cm are particularly preferred, although shorter or longer read ranges may also be acceptable. The particular tag illustrated is the 13.56 mHz tag sold under the brand name Taggit™ available from Texas Instruments, Inc. (<http://www.tiris.com>, Product No. RI-103-110A). The tag **920** has a useful read/write range of about 25 cm and contains 256-bits of on-board memory arranged in 8x32-bit blocks which may be programmed (written) and read by a suitably configured read/write device. If a longer read/write range and/or more memory is desired, optional battery-powered tags may be used instead, such as available from ACXESS, Inc. and/or various other vendors known to those skilled in the art.

[0269] Cards **900** may be collected or traded and/or they may be used to play various games, such as a Pokemon arena competition using an electronic interface capable of reading the card information. Such games may be carried out using a specially configured gaming device or, alternatively, using a conventional computer gaming platform, home game console, arcade game console, hand-held game device, internet gaming device or other gaming device that has been modified to include an RF reader or magnetic "swipe" reader device as illustrated and described above. Advantageously, play participants can use the trading cards **900** to transport information pertinent to a particular depicted person, character or object to a favorite computer action game, adventure game, interactive play structure or the like. For example, a suitably configured video game console and video game may be provided which reads the card information and recreates the appearance and/or traits of particular depicted person, character or object within the game. If desired, the game console may further be configured to write information to the card in order to change or update certain characteristics or traits of the character, person or object depicted by the card **900** in accordance with a predetermined game play progression.

[0270] Of course, those skilled in the art will readily appreciate that the underlying concept of an RFID trading card **900** and card game is not limited to cards depicting fantasy characters or objects, but may be implemented in a wide variety of alternative embodiments, including sporting cards, baseball, football and hockey cards, movie character cards, dinosaur cards, educational cards and the like. If desired, any number of other suitable collectible/tradable tokens or trinkets may also be provided with a similar RFID tag device in accordance with the teachings of the present invention as dictated by consumer tastes and market demand.

[0271] Although this invention has been disclosed in the context of certain preferred embodiments and examples, it will be understood by those skilled in the art that the present invention extends beyond the specifically disclosed embodiments to other alternative embodiments and/or uses of the invention and obvious modifications and equivalents thereof. Thus, it is intended that the scope of the present invention herein disclosed should not be limited by the particular disclosed embodiments described above, but should be determined only by a fair reading of the claims that follow.

1. A method for playing a multi player interactive motion-based game in which a virtual play environment is represented through one or more computer-animated visual, aural or tactile effects, said method comprising:

activating or configuring at least one gaming console to produce one or more computer-animated visual, aural or

tactile effects in accordance with a user-selectable game, said at least one gaming console comprising a first wireless transceiver adapted to provide two-way wireless communications with one or more associated wireless devices;

activating or configuring at least one wireless motion-sensitive input device to be held and moved freely in the air and to be operated by a game participant using a single hand to play said user-selectable game at least in part by moving the entire body of said at least one input device in a shaking, twisting or waving motion, said at least one input device comprising:

a portable housing comprising an elongated body extending along an axis of elongation from a gripping end adapted to be held or gripped by a single hand of a game participant to a pointing end protruding beyond said gripping end and being in substantial collinear alignment therewith, said portable housing enclosing an internal cavity sized and configured so as to contain one or more energy sources and associated electronics for operating said at least one input device; processing circuitry comprising a microprocessor having an associated memory, said memory having stored therein at least one address identifier for uniquely identifying said at least one input device to said at least one gaming console and for distinguishing said at least one input device from one or more other input devices;

motion-sensitive circuitry comprising one or more sensors configured and arranged within said housing so as to produce sensor output data responsive to one or more sensed motions of said housing;

command circuitry comprising at least two finger-actuated switches configured and arranged relative to said housing so as to be selectively actuated by one or more fingers of said single hand to produce switch output data responsive to various combinations of switch actuations; and

a second wireless transceiver adapted to provide two-way wireless communication with at least said first wireless transceiver;

moving said at least one input device in a shaking, twisting or waving motion while simultaneously selectively actuating one, two or none of said at least two finger-actuated switches using said single hand to produce a control signal based at least in part on said sensor output data, said switch output data and said address identifier; and causing said second wireless transceiver to wirelessly transmit said control signal from said second wireless transceiver to said first wireless transceiver, wherein said control signal is received by said first wireless transceiver and used to activate, modify or control said one or more computer-animated visual, aural or tactile effects based, at least in part, on said received control signal.

2. The method of claim 1, wherein said at least one input device comprises a base component adapted to be modularly assembled and functionally intercoupled with one or more auxiliary components and wherein said method further comprises assembling said base component with one or more auxiliary components to selectively create a modified input device having enhanced powers, abilities or functionality.

3. The method of claim 1, wherein said at least one input device further comprises a light-emitting portion configured and adapted to emit a visible or infrared light signal or pattern

and wherein said at least one gaming console is further operatively associated with an external camera configured and adapted to capture one or more digital images of said light signal or pattern and wherein said method comprises the further step of positioning or moving said at least one input device so as to produce a light signal or pattern and wherein said light signal or pattern is used to activate, modify or control said one or more computer-animated visual, aural or tactile effects based at least in part on said one or more captured digital images.

4. The method of claim 1, wherein said gaming console comprises an address storage module configured to store said address identifier of said at least one input device.

5. The method of claim 4, wherein said received control signal comprises information representative of said address identifier and wherein said gaming console is adapted to compare said address identifier transmitted by said control signal with said address identifier stored in said address storage module to recognize or distinguish control signals originating from multiple associated wireless devices.

6. The method of claim 1, wherein said at least one address identifier is configured to facilitate establishing a unique wireless communication link between said first wireless transceiver and said second wireless transceiver, said unique wireless communication link being established at least in part by said first transceiver sending a first wireless signal including a first identification number identifying said first transceiver and said second transceiver receiving and responding to said first transceiver by sending a second wireless signal including said first identification number and a second identification number corresponding to said address identifier for said at least one input device, whereby said control signal may thereafter be based on said address identifier solely by virtue of communicating said control signal using said unique wireless communication link.

7. The method of claim 1, wherein operating at least one wireless motion-sensitive input device comprises operating a first wireless motion-sensitive input device and operating a second wireless motion-sensitive input device sized and configured to be held and moved freely in the air and to be operated by a game participant using a single hand to play said user-selectable game at least in part by moving, shaking, twisting or waving said second input device and wherein said second input device further comprises a second address identifier for uniquely identifying said second input device within said user-selectable game.

8. The method of claim 7, wherein said second input device comprises a third wireless transceiver adapted to provide two-way wireless communication with at least said second wireless transceiver of said first input device.

9. A motion-based interactive gaming system in which a virtual play environment is represented at least in part through one or more computer-animated visual, aural or tactile effects, said gaming system comprising:

at least one gaming console configured and adapted to produce one or more computer-animated visual, aural or tactile effects in accordance with a game, said at least one gaming console comprising a first wireless receiver adapted to receive wireless communications from one or more wireless input devices for activating, modifying or controlling said one or more computer-animated effects; at least one wireless motion-sensitive input device sized and configured to be held and moved freely in the air and operated by a game participant using a single hand to

play said game at least in part by moving said at least one input device through the air in a waving or shaking motion, said at least one input device comprising:

a base component comprising an elongated housing extending along an axis of elongation from a gripping end adapted to be grasped by a single hand of a game participant to a pointing end protruding beyond said gripping end and being substantially in coaxial alignment therewith, said housing substantially enclosing an internal cavity containing one or more energy sources and associated electronics for operating said at least one input device;

motion-sensitive circuitry disposed within said housing comprising at least a first sensor and a second sensor, said first and second sensors being configured and arranged so as to generate sensor output data in response to one or more sensed motions of said at least one input device;

processing circuitry comprising a microprocessor electrically coupled to said first and second sensors and adapted to receive and process said sensor output data, said microprocessor further comprising associated memory having stored therein at least one address identifier for uniquely identifying said at least one input device;

a wireless transmitter configured to wirelessly transmit a control signal to said wireless receiver for activating, modifying or controlling said one or more computer-animated effects, said control signal being based at least in part on said sensor output data and said at least one address identifier; and

at least one auxiliary component configured and adapted to be detachably and modularly assembled with said base component for enabling said game participant to selectively create a modified input device having enhanced powers, capabilities or aesthetics; and

game software adapted to be executed by said gaming system to carry out said game, said game software including program instructions for instructing said at least one gaming console to: i) conduct said game as an interactive game in which a virtual play environment is visually/aurally represented through one or more computer animations, ii) use said address identifier to individually track the game progress or performance for each of said one or more game participants playing said game, and iii) substantially simultaneously adjust the play experience for each of said one or more game participants based at least in part on said tracked game progress or performance.

10. The interactive gaming system of claim **9**, wherein said game software is further configured and adapted to instruct said gaming system to store selected information identifying or describing certain characteristics, attributes, powers or abilities possessed by an imaginary character associated with each of said plurality of game participants playing said game.

11. The interactive gaming system of claim **10**, wherein said game software is further configured and adapted to instruct said gaming system to update or modify said character information based on: i) input provided by each said game participant, ii) selected game play information or results, or iii) information confirming the purchase of one or more auxiliary components or other play objects relevant to said game.

12. The interactive gaming system of claim **9**, wherein said at least one input device further comprises a light bulb, LED

or semiconductor laser adapted and arranged so as to produce a detectable light signal or pattern while a game participant is moving said input device through the air and wherein said interactive gaming system further comprises a digital camera configured to be communicatively coupled to said at least one gaming console, said digital camera being configured and adapted to capture one or more digital images of said light signal or pattern and to communicate said one or more digital images to said gaming console, and wherein said gaming console is further configured and adapted to process said one or more digital images by analyzing the position and/or movement of said light signal or pattern and to thereby activate or control said one or more computer-animated visual, aural or tactile effects based at least in part on said processed digital images.

13. The interactive gaming system of claim **9**, wherein said at least one input device further comprises command circuitry comprising at least two finger-actuated switches operatively associated with said housing, said at least two finger-actuated switches being sized, configured and adapted to be selectively actuated by one or more fingers of a single hand to selectively control at least two bits of input data provided as part of said control signal while said game participant is simultaneously moving said input device through the air, whereby said game participant is able to hold and use said motion-sensitive input device with a single hand to activate, modify or control various computer-animated effects within said game by moving said input device through the air in a waving or shaking motion while simultaneously actuating one, two or none of said at least two finger-actuated switches.

14. The interactive gaming system of claim **9**, further comprising one or more collectible or tradable items comprising a toy, card, trinket, token, doll, action figure or stuffed animal, each said one or more collectible or tradable items physically depicting or representing persons, characters or objects relevant to said game and having associated therewith an electronically-readable tag, each said electronically-readable tag further comprising tag identification information for identifying or tracking each said associated collectible or tradable item and wherein said gaming system is further configured and adapted to:

- i) electronically read each said electronically-readable tag when a selected one or more of said collectible or tradable items is presented by one or more game participants to thereby determine said tag identification information,
- ii) create one or more computer-animated visual, aural or tactile effects having the particular appearance, characteristics and/or traits of said corresponding depicted or represented person, character or object, or
- iii) adjust the game experience for one or more game participants according to said one or more presented collectible or tradable items,

whereby said one or more game participants are able to affect the play of said game by selectively presenting said one or more collectible or tradable items.

15. The interactive gaming system of claim **14**, wherein at least one of said one or more collectible or tradable items comprises an electronically-readable RFID tag and wherein said tag identification information comprises a tag ID uniquely associated with each said RFID tag.

16. The interactive gaming system of claim **15**, wherein said at least one gaming console comprises a first gaming console and a second gaming console and wherein said first gaming console is configured and adapted to produce said one

or more computer-animated visual, aural or tactile effects in accordance with said game and wherein said second gaming console comprises an RFID reader device configured and adapted to:

- i) wirelessly power and electronically read each said electronically-readable RFID tag when a selected one or more of said one or more collectible or tradable items is presented to said second gaming console to thereby determine said tag ID, and
- ii) communicate said tag ID to said first gaming console, whereby said first gaming console can adjust the game experience for said one or more game participants according to said selected one or more collectible or tradable items presented to said second gaming console.

17. The interactive gaming system of claim **9**, wherein said at least one auxiliary component comprises a third sensor configured and arranged so as to generate additional sensor data in response to one or more sensed motions of said at least one input device when said auxiliary component is assembled with said base component, wherein said additional sensor data is different than said sensor output data generated by said first sensor or said second sensor, and wherein said transmitter is further configured to wirelessly transmit a control signal to said wireless receiver based at least in part on said sensor output data, said additional sensor data and said at least one address identifier.

18. The interactive gaming system of claim **9**, wherein said at least one auxiliary component comprises multiple auxiliary components and wherein said multiple auxiliary components are interchangeable such that at least one or more of said multiple auxiliary components can be purchased by a user and interchangeably assembled with said base component and/or selected others of said at least one or more auxiliary components to create an individualized input device having enhanced powers, abilities or aesthetics.

19. The interactive gaming system of claim **9**, wherein said base component comprises an elongated housing having an axis of elongation extending from a proximal end to a distal end and wherein said at least one auxiliary component is configured and adapted for modular detachable assembly to the proximal end of said elongated housing.

20. The interactive gaming system of claim **9**, wherein said at least one input device, when said base component thereof is detachably assembled with said at least one auxiliary component, comprises one or more of the following motion-sensitive toys: magic wand, sword, staff, scepter, whip, paddle, nunchuk, cricket bat, baseball bat, sporting ball, musical instrument, flute, recorder, drum stick, rope, fishing rod, doll, action figure, or stuffed animal.

21. A wireless motion-sensitive input device for playing an interactive game using a wireless-compatible game console in which a virtual play environment is represented through one or more computer-animated visual, aural or tactile effects and wherein game play is conducted at least in part by moving the entire body of said input device in one or more particular motions, said input device comprising:

- a portable housing sized and configured to be held and moved freely in the air by a game participant using a single hand, said portable housing having an axis of elongation extending from a proximal end comprising a gripping portion sized and shaped so as to be grasped and held in said single hand to a distal end comprising a pointing portion extending from said gripping portion and being oriented in substantial coaxial alignment

therewith, said housing further enclosing an internal cavity sized and configured so as to contain one or more energy sources and associated electronics for operating said input device;

- processing circuitry comprising a microprocessor and associated memory, said memory being configured and adapted to store at least one address identifier for uniquely identifying said input device to said wireless-compatible game console;

- motion- or position-sensitive circuitry comprising a plurality of sensors configured and arranged relative to said portable housing so as to one or more particular motions of said input device and produce sensor output data based thereon, said motion- or position-sensitive circuitry comprising at least one sensor for sensing an acceleration force exerted on said input device and at least one sensor for sensing rotation of said input device relative to said axis of elongation;

- command circuitry comprising two or more finger-actuated switches configured and arranged relative to said portable housing so as to be selectively actuated by one or more fingers of said single hand to produce and selectively control at least two bits of switch output data; and a wireless transceiver electrically coupled to said processing circuitry for providing two-way wireless communication with said wireless-compatible game console, said wireless transceiver being configured and adapted to transmit to said game console a control signal based at least in part on said sensor output data, said switch output data and said address identifier;

whereby said input device can be held in the air and operated by a game participant using a single hand to wirelessly activate, modify or control various computer-animated visual, aural or tactile effects by moving said input device in one or more particular motions while simultaneously actuating one, two or none of said two or more finger-actuated switches, and wherein control signals transmitted by said input device can be uniquely identified by said game console and distinguished from other control signals transmitted by one or more other wireless input devices.

22. The input device of claim **21**, wherein said motion- or position-sensitive circuitry comprises one or more of the following: impact sensors, micro-sensors, gyro-sensors, force sensors, micro-switches, momentum sensors, gravity sensors, accelerometers, tilt sensors, orientation sensors, or reed switches.

23. The input device of claim **21**, further comprising an effects generator and associated control circuitry configured and arranged so as to enable said input device to selectively generate at least one visual, aural or tactile effect comprising sound, lighting or vibration in response to a second control signal transmitted by said game console.

24. The input device of claim **21**, further comprising at least one light-emitting module configured and adapted to emit a visible or infrared light signal or pattern capable of being detected by an external camera communicatively coupled to said game console.

25. The input device of claim **24**, wherein said at least one light-emitting module comprises a light bulb, LED or semiconductor laser adapted and arranged to shine a beam or cone of light from the distal end of said housing.

26. The input device of claim **24**, in combination with a wireless-compatible game console and a digital camera, said

digital camera being configured and adapted to capture one or more digital images of said light signal or pattern and to communicate said one or more digital images to said game console, and wherein said game console is configured and adapted to process said one or more digital images by analyzing the position and/or movement of said light signal or pattern and to thereby activate or control said one or more computer-animated visual, aural or tactile effects based at least in part on said processed digital images.

27. The input device of claim 21, wherein said housing comprises a base component adapted to be modularly assembled and functionally interconnected with one or more auxiliary components for enabling a game participant to selectively create or customize a modified input device having enhanced powers, abilities or functionalities.

28. The input device of claim 27, wherein said at least one modified input device, when modularly assembled, comprises one or more of the following: magic wand, sword, staff, scepter, cane, stick, flower, paint brush, crayon, whip, paddle, bat, nunchuk, sporting ball, musical instrument, flute, recorder, fishing rod, doll, action figure, book, jewelry item, crystal ball, or stuffed animal.

29. The input device of claim 21, in combination with a wireless-compatible game console adapted to produce computer-animated visual, aural or tactile effects, said game console further comprising: i) an address storage module configured and adapted to dynamically store multiple address identifiers corresponding to multiple associated wireless input devices; ii) an address comparator for recognizing and distinguishing control signals originating from said multiple associated input devices according to each corresponding address identifier; and iii) a tracking system for tracking game progress or performance of each of a plurality of game participants using said multiple associated wireless input devices to play said interactive game based at least in part on each said recognized address identifier.

30. The input device of claim 21, wherein said memory is further configured and adapted to store selected information identifying or describing certain characteristics, attributes, powers or abilities possessed by an imaginary character associated with said interactive game and wherein said microprocessor is further configured to create or update said character information based on: i) input provided by said game participant, ii) selected game play information or results, or iii) information confirming the purchase of one or more play objects relevant to said interactive game.

31. The input device of claim 21, wherein at least one of said two or more finger-actuated switches comprises a solid-state electronic switch or touch sensor.

32. The input device of claim 21, further comprising a magnetic inductance energy generator disposed within said internal cavity and configured and adapted to generate useable energy from an externally applied electromagnetic field.

33. An interactive gaming system for amusing or entertaining one or more game participants playing an interactive game in which a virtual play environment is represented through one or more computer-animated visual, aural or tactile effects, said interactive gaming system comprising:

at least one gaming console configured and adapted to produce one or more computer-animated visual, aural or tactile effects in accordance with said interactive game, said at least one gaming console comprising a wireless receiver adapted to receive wireless communications

from one or more associated wireless input devices for activating, modifying or controlling said one or more computer-animated effects;

at least one wireless motion-sensitive input device sized and configured to be held and operated by a game participant using a single hand to play said interactive game at least in part by moving the entire body of said input device in a particular motion, said at least one input device comprising:

an elongated housing sized and configured to be held and moved in free space by a game participant using a single hand, said housing extending substantially coaxially along an axis of elongation from a proximal end adapted to be grasped to a distal end adapted to be pointed in a direction indicated by said axis of elongation;

processing circuitry comprising a microprocessor and associated memory, said memory being configured and adapted to store at least one address identifier for uniquely identifying said wireless motion-sensitive input device to said gaming console;

motion- or position-sensitive circuitry electrically coupled to said processing circuitry and configured and arranged so as to provide a first user-directed input signal responsive to one or more sensed motions of said input device, said motion- or position-sensitive circuitry comprising at least one sensor element for sensing an acceleration force exerted on said input device and at least one sensor element for sensing rotation of said input device;

command circuitry electrically coupled to said processing circuitry and comprising at least two finger-actuated switches configured and arranged relative to said housing so as to be selectively actuated by one or more fingers of said single hand while simultaneously moving said input device in a particular motion to selectively control at least two corresponding bits of data comprising a second user-directed input signal; and

a wireless transmitter electrically coupled to said processing circuitry for transmitting wireless communications to said at least one gaming console, said wireless transmitter being configured and adapted to transmit to said wireless receiver a control signal based at least in part on said first and second user-directed input signals and said address identifier;

wherein said at least one gaming console further comprises: i) an address storage module configured and adapted to dynamically store multiple address identifiers corresponding to multiple associated wireless input devices; ii) an address comparator for recognizing or distinguishing control signals originating from said multiple associated input devices; and iii) a tracking system for monitoring and tracking game progress of each of said one or more game participants based at least in part on each said recognized address identifier.

34. The gaming system of claim 33, wherein said at least one gaming console further comprises a second wireless transmitter and said at least one input device further comprises a second wireless receiver for providing two-way wireless communications between said at least one gaming console and said at least one input device.

35. The gaming system of claim 34, wherein said at least one input device further comprises an effects generator and

associated control circuitry configured and arranged so as to enable said at least one input device to selectively generate at least one visual, aural or tactile effect comprising sound, lighting or vibration in response to a second control signal transmitted by said at least one gaming console.

36. The gaming system of claim **35**, wherein said effects generator comprises at least one light-emitting module configured and adapted to emit a visible or infrared light signal or pattern capable of being detected by an external camera communicatively coupled to said gaming console.

37. The gaming system of claim **36**, wherein said at least one light-emitting module comprises a light bulb, LED or semiconductor laser adapted and arranged to shine a beam or cone of light from the distal end of said housing.

38. The gaming system of claim **33**, wherein said at least one input device further comprises a light-emitting portion configured and adapted to emit a visible or infrared light signal or pattern capable of being detected by an external camera.

39. The gaming system of claim **38**, further comprising a digital camera, said digital camera being configured and adapted to capture one or more digital images of said light signal or pattern and to communicate said one or more digital images to said gaming console, and wherein said gaming console is further configured and adapted to process said one or more digital images by analyzing the position and/or movement of said light signal or pattern and to thereby activate or control said one or more computer-animated visual, aural or tactile effects based at least in part on said processed digital images.

40. The gaming system of claim **33**, wherein said at least one input devices comprises a light bulb, LED or semiconductor laser adapted and arranged so as to produce a detectable light signal or pattern while a game participant is moving said input device in a particular motion and wherein said gaming system further comprises a digital camera, said digital camera being configured and adapted to capture one or more digital images of said light signal or pattern and to communicate said one or more digital images to said gaming console, and wherein said gaming console is configured and adapted to process said one or more digital images by analyzing the position and/or movement of said light signal or pattern to thereby activate or control said one or more computer-animated visual, aural or tactile effects based at least in part on said processed digital images.

41. The gaming system of claim **33**, wherein said at least one input devices comprises a base component adapted to be modularly assembled and functionally interconnected with one or more auxiliary components for enabling a game participant to selectively create or customize a modified input device having enhanced powers, abilities or functionality.

42. The gaming system of claim **41**, wherein said at least one modified input device, when modularly assembled, comprises one or more of the following: magic wand, sword, staff, scepter, cane, stick, flower, paint brush, crayon, whip, paddle, bat, nunchuk, sporting ball, musical instrument, flute, recorder, fishing rod, doll, action figure, book, jewelry item, crystal ball, or stuffed animal.

43. The gaming system of claim **33**, wherein said tracking system is further configured and adapted to store selected information identifying or describing certain characteristics, attributes, powers or abilities possessed by an imaginary character associated with each of said one or more game participants playing said interactive game.

44. The gaming system of claim **43**, wherein said tracking system is further configured and adapted to update or modify said character information based on: i) input provided by each said game participant, ii) selected game play information or results, or iii) information confirming the purchase of one or more auxiliary components or other play objects relevant to said interactive game.

45. The gaming system of claim **33**, further comprising an RFID reader device and one or more collectible or tradable items comprising a toy, card, trinket, token, doll, action figure or stuffed animal, each of said one or more collectible or tradable items physically depicting or representing persons, characters or objects relevant to said interactive game and comprising an electronically-readable RFID tag, each said electronically-readable RFID tag further comprising tag identification information for identifying or tracking each said collectible or tradable item and wherein said gaming system is further configured and adapted to:

- i) wirelessly power and electronically read each said electronically-readable RFID tag when a selected one or more of said collectible or tradable items is presented to said RFID reader device to and thereby determine said tag identification information, and
- ii) create one or more computer-animated visual, aural or tactile effects having the particular appearance, characteristics and/or traits of said corresponding depicted or represented person, character or object,

whereby said game system is able to adjust the game experience for one or more game participants according to said one or more presented collectible or tradable items, and

whereby said one or more game participants are able to affect the play of said interactive game by selectively presenting said one or more collectible or tradable items to said RFID reader device.

46. The gaming system of claim **45**, wherein at least one of said one or more collectible or tradable items comprises a paper, cardboard or plastic substrate imprinted with graphics, photos and/or other information and wherein said tag identification information comprises a tag ID uniquely associated with each of said collectible or tradable items.

47. The gaming system of claim **45**, wherein said at least one gaming console comprises a first gaming console and a second gaming console and wherein said first gaming console is configured and adapted to produce said one or more computer-animated visual, aural or tactile effects in accordance with said interactive game and wherein said second gaming console comprises an RFID reader device configured and adapted to:

- i) electronically read each said electronically-readable RFID tag when a selected one or more of said one or more collectible or tradable items is presented to said second gaming console to thereby determine said tag identification information, and
- ii) communicate said tag identification information to said first gaming console,

whereby said first gaming console adjusts the game experience based at least in part on said selected one or more of said one or more collectible or tradable items presented to said second gaming console.

48. The input device of claim **21**, wherein said address identifier is configured to initialize or enable a unique wireless communication link between said input device and said wireless-compatible game console, said unique wireless

communication link being established at least in part by said wireless-compatible game console sending a first wireless signal including a first identification number identifying said game console, and said input device receiving and responding to said first wireless signal by sending a second wireless signal including said first identification number and a second identification number corresponding to said address identifier, wherein once said link is initialized said control signal need not further communicate said address identifier, but said control signal may be based on said address identifier solely by virtue of using said unique wireless communication link.

49. The gaming system of claim **33**, wherein said address identifier is configured to initialize or enable a unique wireless communication link between said at least one input

device and said at least one gaming console, said unique wireless communication link being established at least in part by said gaming console sending a first wireless signal including a first identification number identifying said gaming console, and said input device receiving and responding to said first wireless signal by sending a second wireless signal including said first identification number and a second identification number corresponding to said address identifier, wherein once said link is initialized said control signal need not further communicate said address identifier, but said control signal may be based on said address identifier solely by virtue of using said unique wireless communication link.

* * * * *