

(No Model.)

J. MOTT.
LAND ROLLER.

No. 344,591.

Patented June 29, 1886.

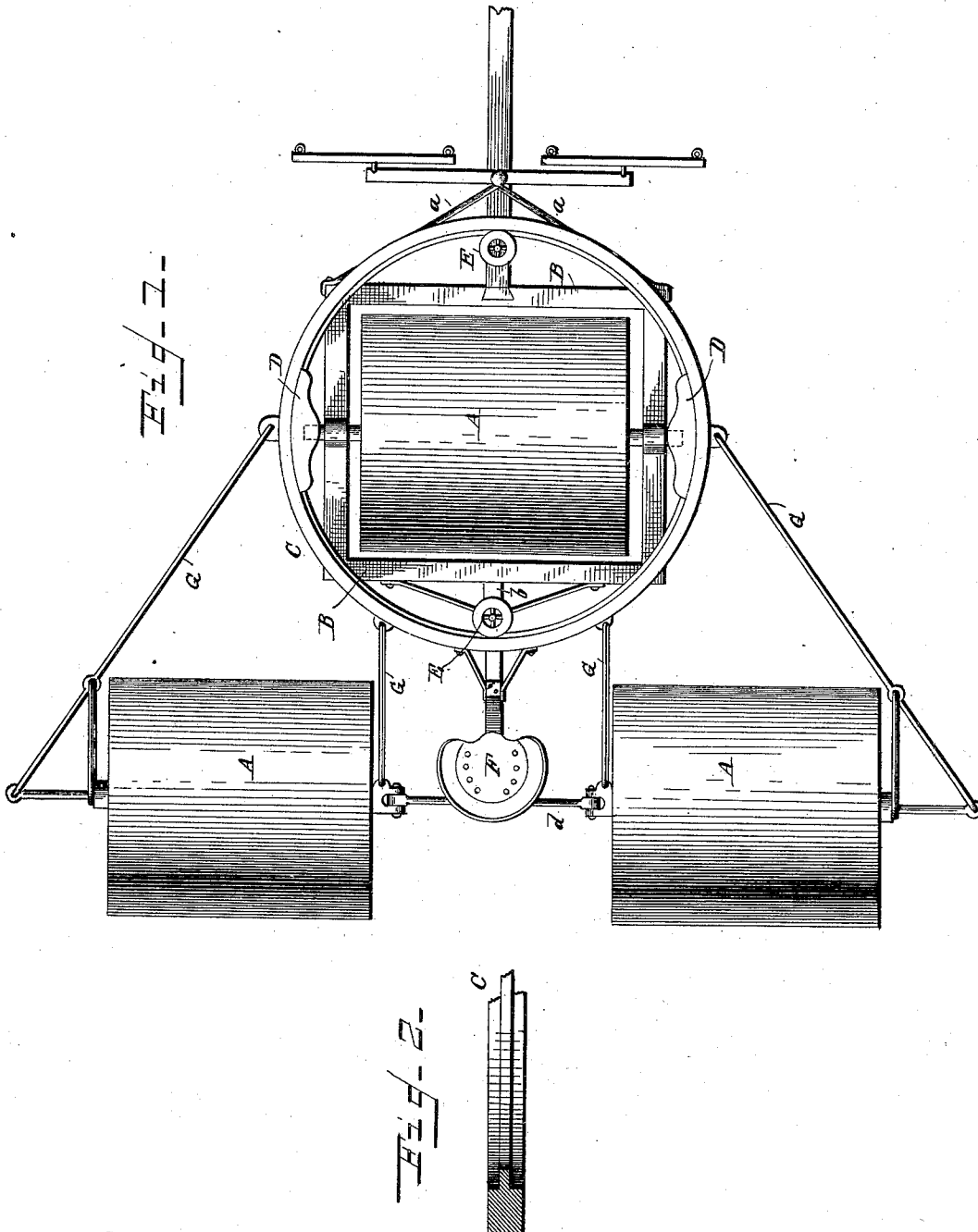

WITNESSES

J. J. Sheehy
Edna Sheehy

INVENTOR

Joseph Mott.
by *Frank Sheehy*
Attorney

UNITED STATES PATENT OFFICE.

JOSEPH MOTT, OF CRYSTAL, DAKOTA TERRITORY.

LAND-ROLLER.

SPECIFICATION forming part of Letters Patent No. 344,591, dated June 29, 1886.

Application filed February 1, 1886. Serial No. 190,443. (No model.)

To all whom it may concern:

Be it known that I, JOSEPH MOTT, a citizen of the United States, residing at Crystal, in the county of Pembina and Territory of Dakota, have invented certain new and useful Improvements in Land-Rollers; and I do declare the following to be a full, clear, and exact description of the invention, such as will enable others skilled in the art to which it appertains to make and use the same, reference being had to the accompanying drawings, and to the letters and figures of reference marked thereon, which form a part of this specification.

This invention has relation to improvements in land-rollers; and it consists in the construction, novel arrangement, and adaptation of devices, as will be hereinafter more fully set forth and claimed.

In the annexed drawings, Figure 1 is a plan view of a land-roller constructed according to my invention, and Fig. 2 is a sectional detail view of the ring.

Referring by letter to the said drawings, A indicates the rollers, which are three in number—one in front and two in the rear—the front roller being arranged in a plane coincident with the interval between the rear rollers. The forward roller is surrounded horizontally by a rectangular frame, which has bearings on the journals of the said roller. The rear end of the draft-beam is secured to the forward portion of this frame B, and brace-rods *a* extend from the forward corners of the frame to the said draft-beam, as shown. The said frame B is provided on its rear side, and preferably at a point diametrically opposite the draft-beam, with a short rigid arm, *b*, which is also braced in a similar manner to that of the said draft-beam.

C indicates a metallic ring, which may be provided with an internal annular flange to receive the bearings D for the journals of the forward roller. These bearings D are curved on their outer sides and grooved externally to receive the said annular flange of the ring.

E E indicate horizontal rollers or flanged wheels, which are arranged, respectively, on the draft-beam and the short arm *b* of the

frame B. These rollers are designed to engage the annular flange of the ring, as shown.

F indicates the driver's seat, which is fixed to the rear portion of the ring.

The rear rollers are provided with independent axles and connected together by means of a hinge-bar, *d*, the axles being also pivotally connected to the lateral and rear portions of the ring C from their respective ends by means of rods G. By this construction illustrated it will be seen that the roller may be drawn over uneven ground without throwing the tongue or draft-beam against the animals. It will also be seen that the rear rollers may have an independent vertical movement and an interdependent connection with the draft-frame. It will further be seen that the forward roller and its frame, together with the draft-beam, may be moved to the right or left, or turned without affecting the movements of the hind rollers.

I attach importance to the employment of the ring, and to the fact that the forward roller-frame is not connected with the rear rollers.

Having described this invention, what I claim is—

1. A land-roller having its forward roller bearing in a movable ring arranged on a horizontal plane coincident with the axial center of the said roller, and its rear rollers having hinged connections with the said ring, substantially as specified.

2. The combination, with the forward roller and frame surrounding the same, of the ring carrying the driver's seat, and the rollers engaging the said ring, substantially as specified.

3. The combination, in a land-roller, of the ring arranged on a horizontal plane, and coincident, or nearly so, with the axial center of the forward roller, the forward roller having movable bearings in the said ring and roller-connections with the frame of the said roller, substantially as specified.

4. The combination, with the ring having the internal annular flange arranged as described, of the forward roller, the frame surrounding the same and connecting with the said draft-beam, the movable bearings for the roller supported in the ring, and the rollers

supported in the frame of the forward roller and draft-beam, and engaging the interior of the said ring, substantially as specified.

5 The combination, in a land-roller, of the ring and roller supported therein by movable bearings and roller-connections, and the rear rollers having independent hinged connections with the said ring, substantially as specified.

In testimony whereof I affix my signature in presence of two witnesses.

JOSEPH MOTT.

Witnesses:

ISAAC STOVIN,
FRED. WEISS.