

F. O. & F. E. STANLEY.

MACHINE FOR MANUFACTURING PHOTOGRAPHIC DRY PLATES.

No. 345,331.

Patented July 13, 1886.

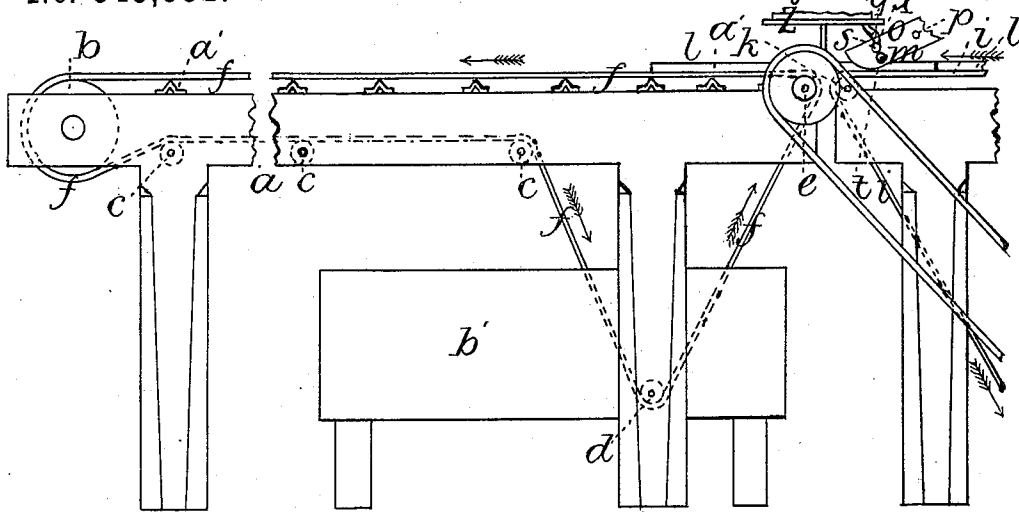

FIG. 1.

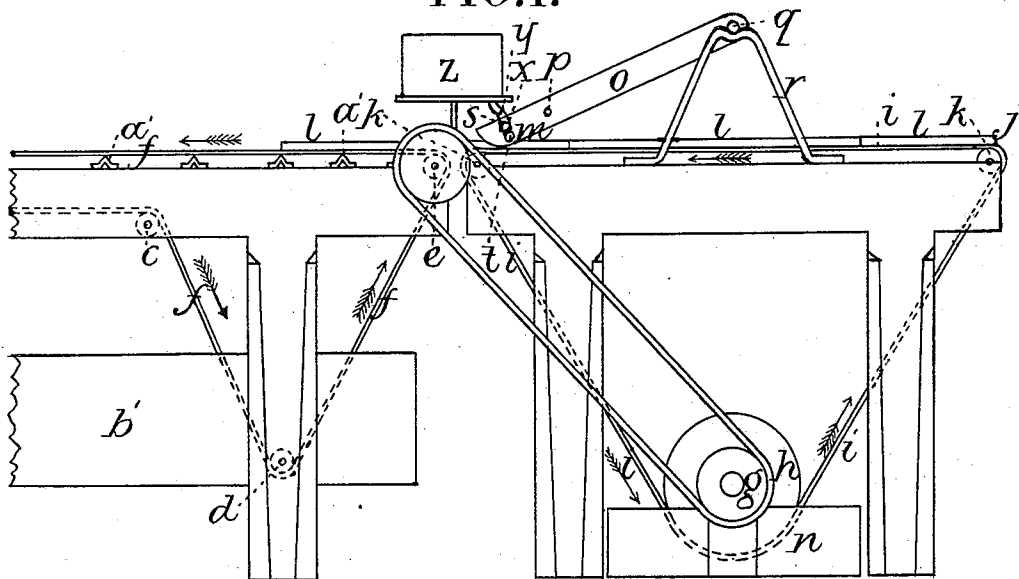

FIG. 2.

WITNESSES:

John E. Moore
Henry Sabine

INVENTORS:

Freelan Stanley
Frank E. Stanley

F. O. & F. E. STANLEY.

MACHINE FOR MANUFACTURING PHOTOGRAPHIC DRY PLATES.

No. 345,331.

Patented July 13, 1886.

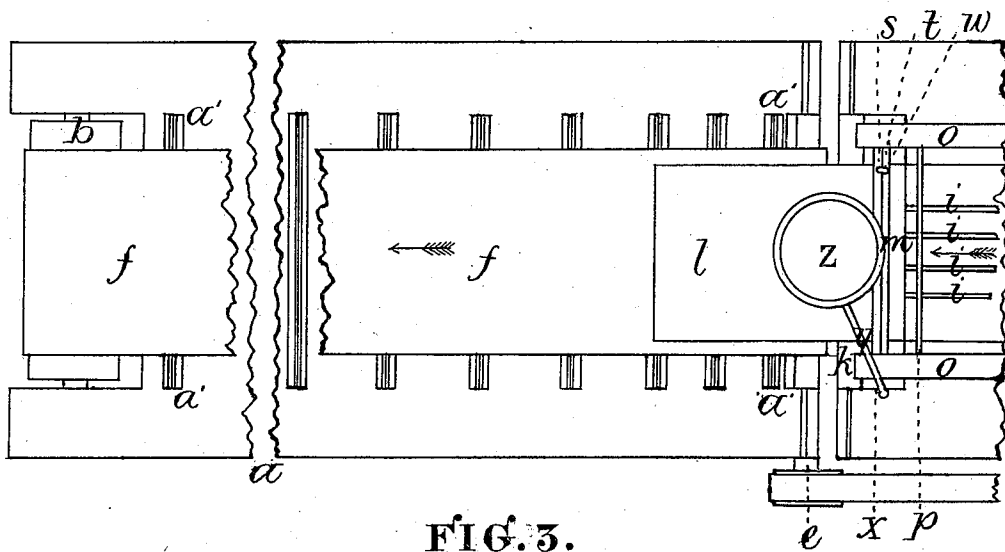

FIG. 3.

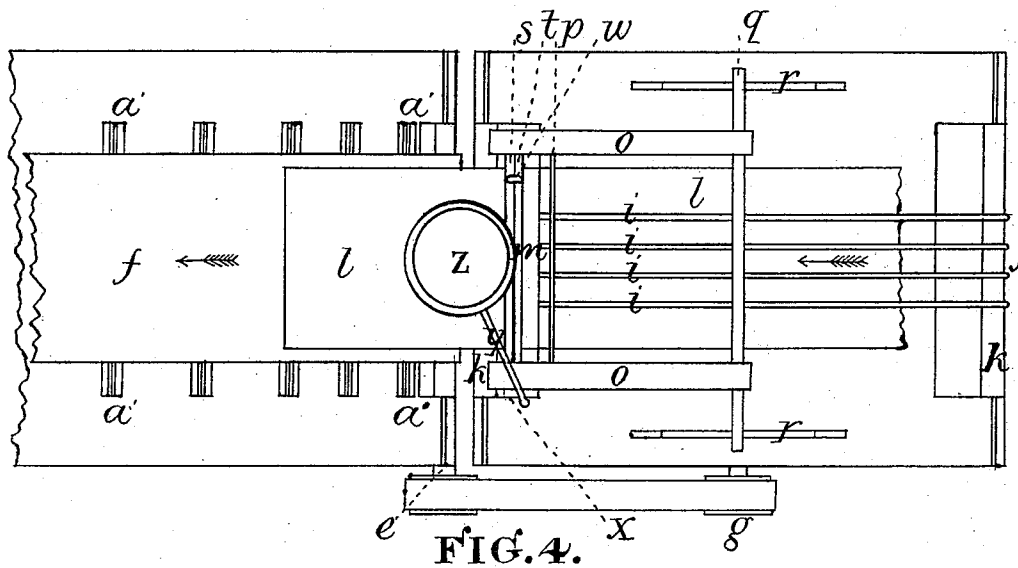

FIG. 4.

WITNESSES:

John C. Moore
Henry Sabine

INVENTORS:

Frederic O. Stanley
Frank E. Stanley

(No Model.)

3 Sheets—Sheet 3.

F. O. & F. E. STANLEY.

MACHINE FOR MANUFACTURING PHOTOGRAPHIC DRY PLATES.

No. 345,331.

Patented July 13, 1886.

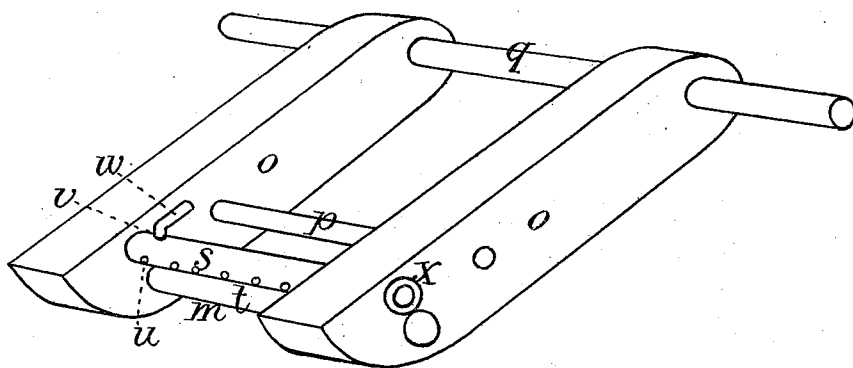

FIG. 5.

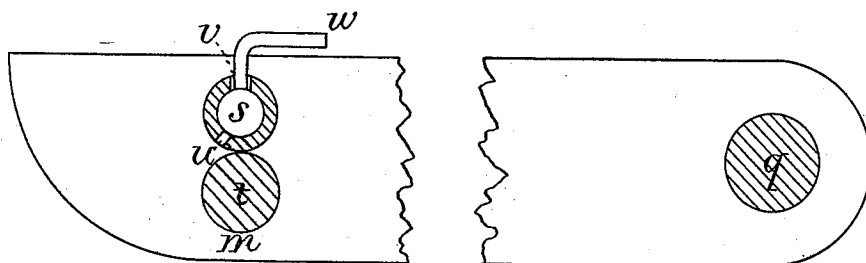

FIG. 6.

WITNESSES:

John C. Moore

Henry Sabin

INVENTORS:

Fulton O. Stanley

Frank S. Stanley

UNITED STATES PATENT OFFICE.

FREELAN O. STANLEY, OF LEWISTON, AND FRANK E. STANLEY, OF AUBURN,
MAINE.

MACHINE FOR MANUFACTURING PHOTOGRAPHIC DRY-PLATES.

SPECIFICATION forming part of Letters Patent No. 345,331, dated July 13, 1886.

Application filed August 27, 1885. Serial No. 175,423. (No model.)

To all whom it may concern:

Be it known that we, FREELAN O. STANLEY and FRANK E. STANLEY, citizens of the United States, of Lewiston and Auburn, respectively, in the county of Androscoggin and State of Maine, have invented a certain new and useful Machine for the Manufacturing of Photographic Dry-Plates, and called a "Coating-Machine;" and we do hereby declare that the following is a full, clear, and exact description of the invention, which will enable others skilled in the art to which it appertains to make and use the same, reference being had to the accompanying drawings, and to letters of reference marked thereon, which form a part of this specification.

Figure 1 represents a side view of part of the coating-machine, a section being taken out at *a*. A section is cut off at the right of the view in Fig. 1. The continuation of Fig. 1 may be seen in Fig. 2. Figs. 3 and 4 are top plans of Figs. 1 and 2, respectively. Fig. 5 is a perspective view of the device for the coating of the plate, and Fig. 6 is a sectional view of Fig. 5.

Same letters show like parts.

Our invention relates to the manufacturing of photographic dry-plates.

Our improvements consist in the method of coating the glass plate, the "setting process" or hardening of the coating after it is applied to the plate, and the method of securing uniformity of flow of the photographic emulsion upon the plate.

Power is communicated to the machine by belt to pulley at end of roll *b*.

Rolls *b*, *c*, *d*, and *e* are connected by belt *f*, passing round them in direction indicated by arrow.

Power is communicated from pulley at end of roll *e* to pulley *g* at end of drum-pulley *h*.

i i i i are cord or rope belts passing round grooved rolls *k k*. These rope belts may be placed nearer together or farther apart, as is necessary to support the glass plate, which they carry along, and which is placed upon them one after another and in immediate contact at the point *j*. These cord or rope belts take the direction indicated by arrow.

The glass plate *l*, to be coated, is placed by the operator on the cord belts at the point *j*,

and by these cords carried along under the coater at the point *m*. The process of coating will be described hereinafter. Immediately after receiving the coating the plate passes from the rope belts to the belt *f*, this latter being distant from the rope belts about one-half inch. The plate is now carried along by the belt to the point *b*, where a second operator removes the plate and sets it away to dry. The rope belts pass through a tank, *n*, of tepid water, and any emulsion upon the belts is thus washed off.

Fig. 5 is the coater.

o o are the parallel sides of a frame, and are held in place by the connecting-rods *p* and *q*. The rod *q* extends through the sides *o o*, and its ends serve as a shaft, resting in the bearings *r*, these bearings being elevated above the rope belts. Through the sides *o o* run a tube, *s*, and a glass rod, *t*, the tube placed directly above the rod and each in contact with the other their entire length, as seen in Fig. 5. The tubes, on its under side along its entire length, on a line immediately at the left of its point of contact with the glass rod *t*, as seen in Fig. 5, is punctured with a series of small holes, *u*, one of which is plainly seen in Fig. 6. This tube *s* is also punctured on its upper side with a small hole at *v*. To this latter puncture is fitted a peg, *w*, removable at pleasure. The glass rod *t* rests on the rope belts or on the glass plates when the plate is being coated and carried along by the rope belts. The photographic emulsion is introduced into the tube *s* at the point *x* by means of additional flexible tubing, *y*, connected with a jar, *z*, located near by.

To secure uniform flow of emulsion through flexible tube *y*, connected with the coater, this flexible tube *y* is connected with a jar, *z*, in which the height of the emulsion is regulated by an ordinary trap-valve as it (the emulsion) comes from a tank containing the stock solution. As the emulsion is introduced into the tube *s*, the peg *w* is removed, that all air may escape. The air having been driven out, the peg *w* is returned to its place. The emulsion thus introduced escapes through the punctures before described, and overflows the glass rod *t* on the side next to the belt *f*. The emulsion then flows downward over the glass rod *t* until

it reaches the glass plate *l*, which is being carried along by the rope belts, and by capillary attraction the emulsion is then uniformly spread over the glass plate. The belt *f* passes
5 over tin rests or supports *a'*, which extend across the part uppermost of the machine from side to side, as seen in Figs. 3 and 4. Their purpose is to keep level the belt *f* and the coated plate passing along, while the friction of the
10 belt is less than if passed over a plane surface. *b'* represents a tank filled with ice-water, through which the belt *f* passes, as seen at the point *d* in Figs. 1 and 2. As the belt comes from the tank *b'* and reaches the roll *e*, where it re-
15 ceives the just-coated plate *l*, its (the belt's) temperature is low. It then receives the plate, and the temperature of the latter is thus lowered, and the coating begins to harden or set immediately, being fully set when it reaches
20 the point *b*, where it is removed by the second operator.

What we claim as our invention, and desire to secure by Letters Patent of the United States, is—

1. In a machine for coating photographic 25 plates, the combination of the perforated tube *s* and the glass rod *t*, placed in contact therewith, substantially as described.

2. In a machine for coating photographic 30 plates, a belt saturated with ice-water or other cold liquid for the purpose of chilling or setting the emulsion, substantially as hereinbefore set forth.

In testimony that we claim the foregoing as our own we affix our signatures in presence of 35 two witnesses.

FREELAN O. STANLEY.
FRANK E. STANLEY.

Witnesses:

JOHN E. MOORE,
HENRY SALNIC.