

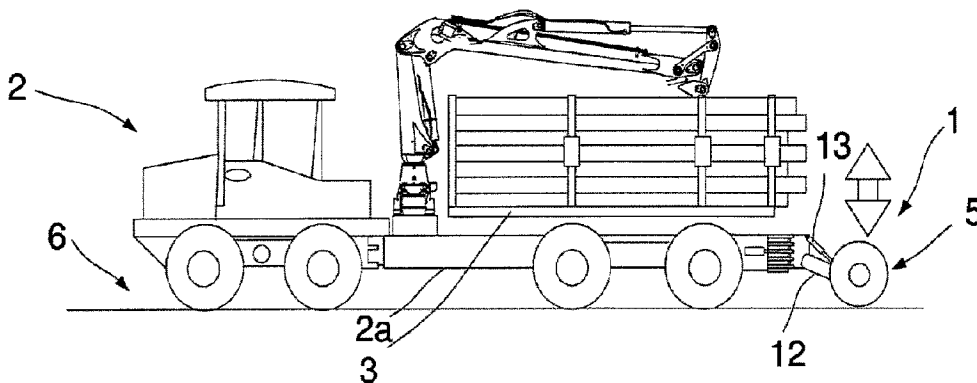

(86) Date de dépôt PCT/PCT Filing Date: 2016/06/13
 (87) Date publication PCT/PCT Publication Date: 2017/01/12
 (45) Date de délivrance/Issue Date: 2023/08/29
 (85) Entrée phase nationale/National Entry: 2017/12/29
 (86) N° demande PCT/PCT Application No.: SE 2016/050568
 (87) N° publication PCT/PCT Publication No.: 2017/007394
 (30) Priorité/Priority: 2015/07/03 (SE1550969-8)

(51) Cl.Int./Int.Cl. *B62D 61/12* (2006.01),
B62D 55/02 (2006.01)
 (72) Inventeurs/Inventors:
NILSSON, ERIK, SE;
BOSTROM, OLA, SE
 (73) Propriétaire/Owner:
KOMATSU FOREST AB, SE
 (74) Agent: SMART & BIGGAR LP

(54) Titre : AGENCEMENT ET VEHICULE
 (54) Title: ARRANGEMENT AND VEHICLE



(57) **Abrégé/Abstract:**

This invention concerns an arrangement (1) intended to be mounted at a vehicle (2), comprising a load-bearing part (3) and driving wheels (4), where the arrangement (1) comprises at least two extra wheels (5) that can be individually controlled in the vertical direction and that are mounted at the vehicle (2) in order to distribute the weight of the vehicle, the gross weight of the vehicle including its payload weight, over more areas of the support (6), the ground, and in this way improve the distribution of weight and reduce the pressure exerted against the support, the ground. Each of the individually controlled extra wheels (5) comprises a pair of wheels and is subject to a driving force. The invention concerns also a vehicle (2) comprising such an arrangement (1).

(12) INTERNATIONAL APPLICATION PUBLISHED UNDER THE PATENT COOPERATION TREATY (PCT)

(19) World Intellectual Property
Organization
International Bureau(10) International Publication Number
WO 2017/007394 A1(43) International Publication Date
12 January 2017 (12.01.2017)

- (51) **International Patent Classification:**
B62D 61/12 (2006.01) *B62D 55/02* (2006.01)
- (21) **International Application Number:**
PCT/SE2016/050568
- (22) **International Filing Date:**
13 June 2016 (13.06.2016)
- (25) **Filing Language:** Swedish
- (26) **Publication Language:** English
- (30) **Priority Data:**
1550969-8 3 July 2015 (03.07.2015) SE
- (71) **Applicant:** KOMATSU FOREST AB [SE/SE]; P.O. Box 7124, 907 04 Umeå (SE).
- (72) **Inventors:** NILSSON, Erik; Byvägen 17C, 913 42 Obbola (SE). BOSTRÖM, Ola; Marinvägen 19, 907 88 Täfteå (SE).
- (74) **Agent:** ZACCO SWEDEN AB; P.O. Box 5581, Valhallavägen 117N, 114 85 Stockholm (SE).
- (81) **Designated States** (unless otherwise indicated, for every kind of national protection available): AE, AG, AL, AM, AO, AT, AU, AZ, BA, BB, BG, BH, BN, BR, BW, BY, BZ, CA, CH, CL, CN, CO, CR, CU, CZ, DE, DK, DM,

DO, DZ, EC, EE, EG, ES, FI, GB, GD, GE, GH, GM, GT, HN, HR, HU, ID, IL, IN, IR, IS, JP, KE, KG, KN, KP, KR, KZ, LA, LC, LK, LR, LS, LU, LY, MA, MD, ME, MG, MK, MN, MW, MX, MY, MZ, NA, NG, NI, NO, NZ, OM, PA, PE, PG, PH, PL, PT, QA, RO, RS, RU, RW, SA, SC, SD, SE, SG, SK, SL, SM, ST, SV, SY, TH, TJ, TM, TN, TR, TT, TZ, UA, UG, US, UZ, VC, VN, ZA, ZM, ZW.

(84) **Designated States** (unless otherwise indicated, for every kind of regional protection available): ARIPO (BW, GH, GM, KE, LR, LS, MW, MZ, NA, RW, SD, SL, ST, SZ, TZ, UG, ZM, ZW), Eurasian (AM, AZ, BY, KG, KZ, RU, TJ, TM), European (AL, AT, BE, BG, CH, CY, CZ, DE, DK, EE, ES, FI, FR, GB, GR, HR, HU, IE, IS, IT, LT, LU, LV, MC, MK, MT, NL, NO, PL, PT, RO, RS, SE, SI, SK, SM, TR), OAPI (BF, BJ, CF, CG, CI, CM, GA, GN, GQ, GW, KM, ML, MR, NE, SN, TD, TG).

Declarations under Rule 4.17:

- as to the identity of the inventor (Rule 4.17(i))
- as to applicant's entitlement to apply for and be granted a patent (Rule 4.17(ii))

Published:

- with international search report (Art. 21(3))

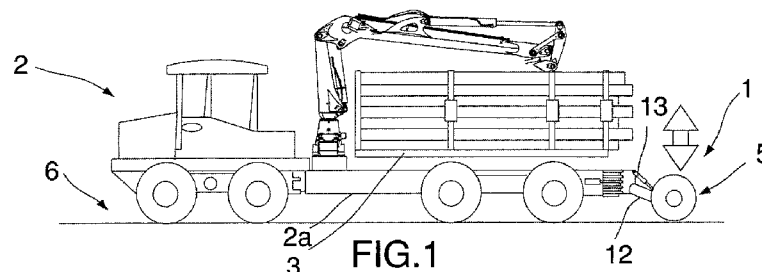
(54) **Title:** ARRANGEMENT AND VEHICLE

(57) **Abstract:** This invention concerns an arrangement (1) intended to be mounted at a vehicle (2), comprising a load-bearing part (3) and driving wheels (4), where the arrangement (1) comprises at least two extra wheels (5) that can be individually controlled in the vertical direction and that are mounted at the vehicle (2) in order to distribute the weight of the vehicle, the gross weight of the vehicle including its payload weight, over more areas of the support (6), the ground, and in this way improve the distribution of weight and reduce the pressure exerted against the support, the ground. Each of the individually controlled extra wheels (5) comprises a pair of wheels and is subject to a driving force. The invention concerns also a vehicle (2) comprising such an arrangement (1).

WO 2017/007394 A1

Arrangement and vehicle

TECHNICAL AREA

This invention concerns an arrangement intended to be mounted at a vehicle that comprises a load-bearing part and driving wheels. The invention concerns also a vehicle comprising such an arrangement.

BACKGROUND

Vehicles, machines, agricultural machines and forestry machines have long been used within forestry in order to automate many of the operations that are to be carried out on location in a forest. The vehicles have a weight that is not insignificant, independently of whether they are driven with the aid of wheels or tracks, which means that the forest, the support of the vehicle in the forest, the ground, over which the vehicle is driven and on which it stands, is affected. The ground is compressed by the weight of the vehicle and the damage to the ground may be permanent in the form of damage that does not recover without intervention. This damage to the ground may result in erosion, leakage of humus and nutrients, the unplanned formation of ditches, and compression of the pore system of the ground, all of which may have consequences. All such consequences affect the remaining forest, through, for example, lower resistance to storms due to roots that are torn off and/or thick roots that are shallow, to increased root rot as a consequence of root damage, and to loss of growth. Once the damage has taken place, all attempts to restore the ground are expensive, or totally impossible.

Repair of damage caused by driving is most often of a cosmetic nature. Up to half of the support capacity of the ground arises from the roots. The support capacity is, therefore, difficult to restore when the vegetation and root systems have been broken. Furthermore, repair by, for example, the use of an excavator means that the ground is excavated one more time. This increases further the risk for the undesired transport of slurry, humus, nutrients and heavy metals into lakes and watercourses. For these reasons, the damage caused by driving should be attempted to be prevented as far as possible.

In order to avoid damage to the ground and damage caused by driving, a great deal of time has been invested in planning appropriate routes, passages and collection points well in advance of a felling operation. This is not only time-consuming but also expensive.

The compression of the ground by the weight of the vehicle can lead also to the driving of the vehicle becoming more difficult.

SUMMARY OF THE INVENTION

One purpose of the present arrangement is to reduce the influence on the forest from a vehicle, on the support of a vehicle in the forest, on the ground, where the vehicle is driven or allowed to stand.

According to an aspect of the present invention, there is provided an arrangement intended to be mounted at a vehicle intended for forestry, comprising a load-bearing part and driving wheels, where the arrangement comprises at least two sets of extra wheels, each set being configured to be individually controlled in the vertical direction, the extra wheels of each set being mounted at the vehicle in order to distribute the weight of the vehicle, the gross weight of the vehicle including its payload weight, over more areas of the support, the ground, and in this way improve the distribution of weight and reduce the pressure exerted against the support, the ground, wherein each set of the individually controlled extra wheels comprises a pair of wheels and is subject to a driving force.

According to another aspect of the present invention, there is provided a vehicle comprising a load-bearing part, driving wheels and an arrangement as described above.

DESCRIPTION OF DRAWINGS

Figure 1 shows a vehicle and an arrangement according to an embodiment of the invention.

Figure 2 shows the arrangement and the vehicle in Figure 1 seen from above.

Figure 3 shows the arrangement and the vehicle in Figure 1 seen from above.

Figure 4 shows two extra wheels comprised in an arrangement according to an embodiment of the invention on various supports.

Figure 5 shows a second embodiment of an arrangement and a vehicle according to the invention.

Figure 6 shows the arrangement and the vehicle in Figure 5 seen from above.

Figure 7 shows the arrangement and the vehicle in Figure 5 seen from above.

Figure 8 shows a further embodiment of the invention.

Figure 9 shows an auxiliary motor comprised in an arrangement according to an embodiment of
5 the invention.

Figure 10 shows a damping arrangement comprised in an arrangement according to an
embodiment of the invention.

DESCRIPTION OF EMBODIMENTS

An embodiment of this invention concerns an arrangement 1 intended to be mounted at a vehicle
10 2 that comprises a load-bearing part 3 and driving wheels 4. See Figure 1-Figure 8.

The arrangement 1 comprises at least two individually controlled extra wheels 5 mounted at the
vehicle 2, where it is appropriate that one wheel is located on each side of the vehicle 2, such that
two extra wheels 5 are located in a pair, in order to distribute the weight of the machine, the gross
weight of the machine including the weight of its payload, over more areas of the support 6, the
15 ground. This

improves the distribution of weight and reduces the pressure on the support, the ground, exerted by the vehicle 2. The extra wheels 5 give a direct support and a supplementary ability to distribute the weight, in addition to the normal vehicle wheels 4.

5 The term “individually controlled extra wheels 5” is here used to denote that each extra wheel, independently of its location on the vehicle 2, can be controlled and adjusted and can follow the support 6, without being influenced by, and without influencing, other extra wheels and their locations. It is possible also that two extra wheels 5 be located on the same side of the vehicle 2, if this is required in special terrain. It is possible also that more than two extra wheels 5 be mounted at a vehicle.

10 The individually controlled extra wheels 5 may have different designs. It is appropriate that each extra wheel 5 comprises a pair of wheels 5a. Each extra wheel may also comprise also a wheel bogie pair 5b. See Figure 1 and Figure 5.

The individually controlled extra wheels 5 are subject to a driving force. The driving force on the wheels further facilitates the driving of the vehicle 2 on the support, and since the extra wheels 5 are driven
15 and move relative to the support, the extra wheels 5 will be in motion and will not become as easily stuck in such material as is located on the support 6, such as, for example, vegetation.

The individually controlled extra wheels 5 may be hydraulically driven or electrically driven. It is appropriate that the arrangement comprise an auxiliary motor 7 that drives the extra wheels 5. The motor is driven by a hydraulic system comprising a pump 8. The pump 8 is driven by an additional
20 source of energy 9, such as, for example, a diesel engine. See Figure 9.

In order that the extra wheels 5 are to offer support where it is most needed, for the balance of the vehicle 2 on the support 6 and possibly also for improved driving of the vehicle 2 over the support 6, the individually controlled extra wheels 5 are mounted at the vehicle 2 at appropriate locations on the vehicle 2. The individually controlled extra wheels 5 may be mounted at the vehicle 2 on a part 10 of
25 the vehicle 2 that can be controlled or on a fixed part 11 of the chassis system 2a of the vehicle that cannot be controlled. In the case in which the extra wheels 5 are mounted at the vehicle 2 through a part 10 of the vehicle 2 that can be controlled, this part 10 is jointed at at least one vertical bearing 10a and is controlled with the aid of at least two control cylinders 10b. See Figure 1, Figure 5 and Figure 8.

The arrangement 1 comprises at least two damped, jointed, spring-mounted arms 12 on which the
30 extra wheels 5 are mounted. One arm 12 is arranged on each side of the vehicle. Each arm 12 is individually controlled and mounted in bearings, and can move independently of the motion of the other arm. See Figure 4.

Each arm 12 comprises a damping arrangement 13 that damps the motion of the arm, and a rotatable shaft 14 that is mounted in bearings and supports the extra wheel 5. The rotatable shaft 14 that is mounted in bearings supports the wheel axle 15 of a pair of wheels. See Figure 4.

5 It is appropriate that the damping arrangement 13 of the arm comprise a damped cylinder that retains, presses, the extra wheel 5 against the support 6 in order to ensure that the extra wheel 5 is in contact with the support 6 and in this way improve the distribution of weight and reduce the pressure exerted by the vehicle 2 onto the support 6, the ground. The damping arrangement, the damped cylinder 13, is controlled by a hydraulic unit 16 that is fed by a hydraulic pump 17 that obtains its energy from a selected source of energy 18, such as, for example, an electric motor, a diesel engine or other source of
10 energy or source of power. See Figure 10.

The damping arrangement, the damping cylinder 13, comprises an accumulator 19 that offers a spring facility and that can store energy for a short period. See Figure 10.

The invention concerns also a vehicle 2 comprising an arrangement 1 of the type that has been described above. The load-bearing part 3 of the vehicle comprises a conventional load-bearing frame.
15 The load-bearing part 3 may comprise also a separate displaceable load carrier. The driving wheels 4 of the vehicle comprise a mechanically driven, a hydraulically driven, or an electrically driven bogie 22.

The vehicle 2 is intended to be used within forestry or agriculture since it is within these fields of use that it is economically and biotopically interesting that damage to the ground is avoided or at least minimised. Other fields of use in which damage to the ground should be avoided or at least minimised
20 may, of course, become relevant.

CLAIMS:

1. An arrangement intended to be mounted at a vehicle intended for forestry, comprising a load-bearing part and driving wheels, where the arrangement comprises at least two sets of extra wheels, each set being configured to be individually controlled in the vertical direction, the extra wheels of each set being mounted at the vehicle in order to distribute the weight of the vehicle, the gross weight of the vehicle including its payload weight, over more areas of the support, the ground, and in this way improve the distribution of weight and reduce the pressure exerted against the support, the ground, wherein each set of the individually controlled extra wheels comprises a pair of wheels and is subject to a driving force.
2. The arrangement according to claim 1, where each of the individually controlled extra wheels comprises a wheel bogie.
3. The arrangement according to claim 1 or 2, comprising an auxiliary motor that drives an extra wheel of a pair of wheels of a set of the extra wheels.
4. The arrangement according to claim 3, where the motor is driven by a hydraulic system comprising a pump.
5. The arrangement according to claim 4, comprising a source of energy that drives the pump.
6. The arrangement according to any one of claims 1 to 5, where the individually controlled extra wheels are mounted at the vehicle on part of the vehicle that can be controlled.
7. The arrangement according to claim 6, where the part of the vehicle that can be controlled is jointed at at least one set of vertical bearings and is controlled with the aid of at least two control cylinders.

8. The arrangement according to any one of claims 1 to 5, where the individually controlled extra wheels are mounted at the vehicle on a part of the chassis system of the vehicle that cannot be controlled.
9. The arrangement according to any one of claims 1 to 8, comprising at least two arms
5 on which the extra wheels are mounted.
10. The arrangement according to claim 9, where each arm is individually controlled and mounted in bearings, and can move independently of the motion of the other arm.
11. The arrangement according to claim 9 or 10, where each arm comprises a damping arrangement that damps the motion of the arm, and a rotatable shaft that is mounted in bearings
10 and supports the extra wheel.
12. The arrangement according to claim 11, where the rotatable shaft that is mounted in bearings supports a wheel axle of a pair of wheels.
13. The arrangement according to claim 11 or 12, where the damping arrangement comprises a damping cylinder that is controlled by a hydraulic unit that is fed by a hydraulic pump
15 that obtains its energy from a selected source of energy.
14. The arrangement according to any one of claims 11 to 13, comprising an accumulator that offers a spring facility and that can store energy for a short period.
15. A vehicle comprising a load-bearing part, driving wheels and an arrangement according to any one of claims 1 to 14.
- 20 16. The vehicle according to claim 15, where the load-bearing part comprises a conventional load-bearing frame.
17. The vehicle according to claim 15 or 16, where the load-bearing part comprises a separate displaceable load carrier.

18. The vehicle according to any one of claims 15 to 17, where the driving wheels comprise a mechanically driven bogie.

19. The vehicle according to any one of claims 15 to 17, where the driving wheels comprise a hydraulically driven bogie.

5 20. The vehicle according to any one of claims 15 to 17, where the driving wheels comprise an electrically driven bogie.

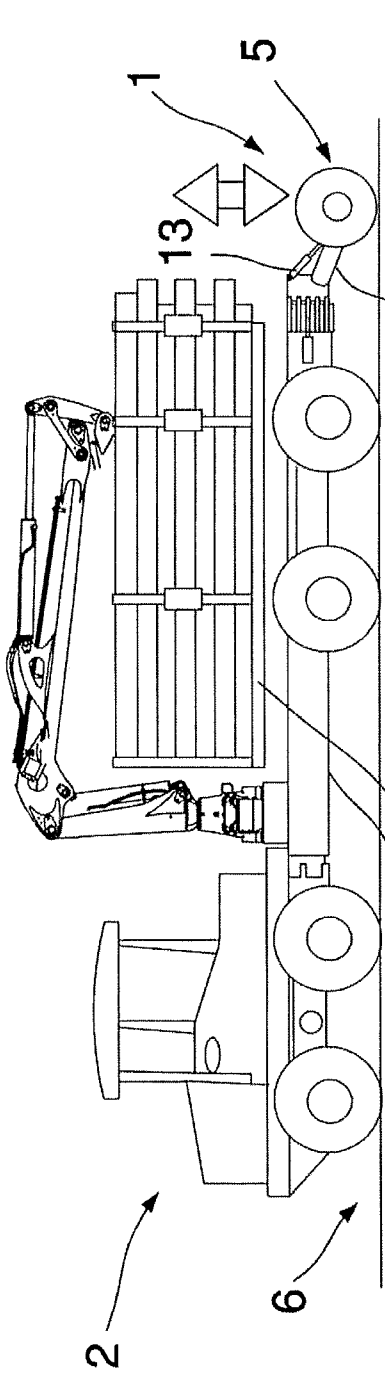

FIG. 1

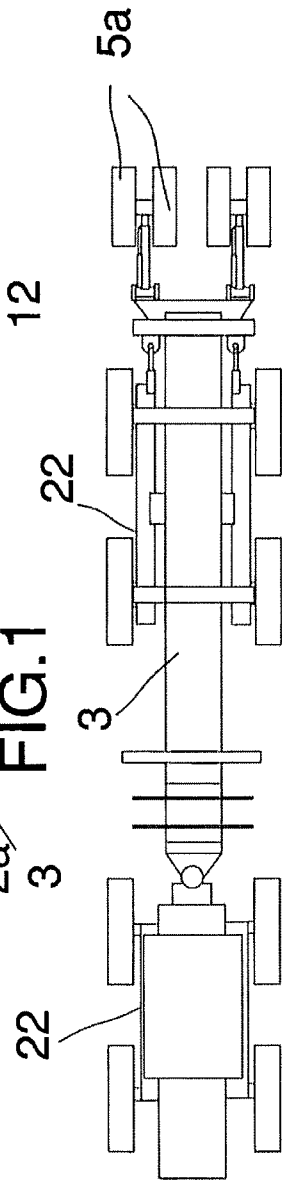

FIG. 2

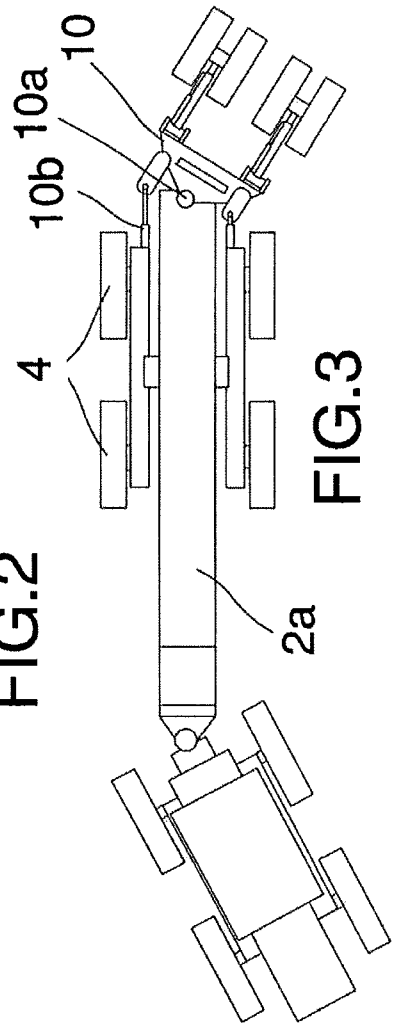
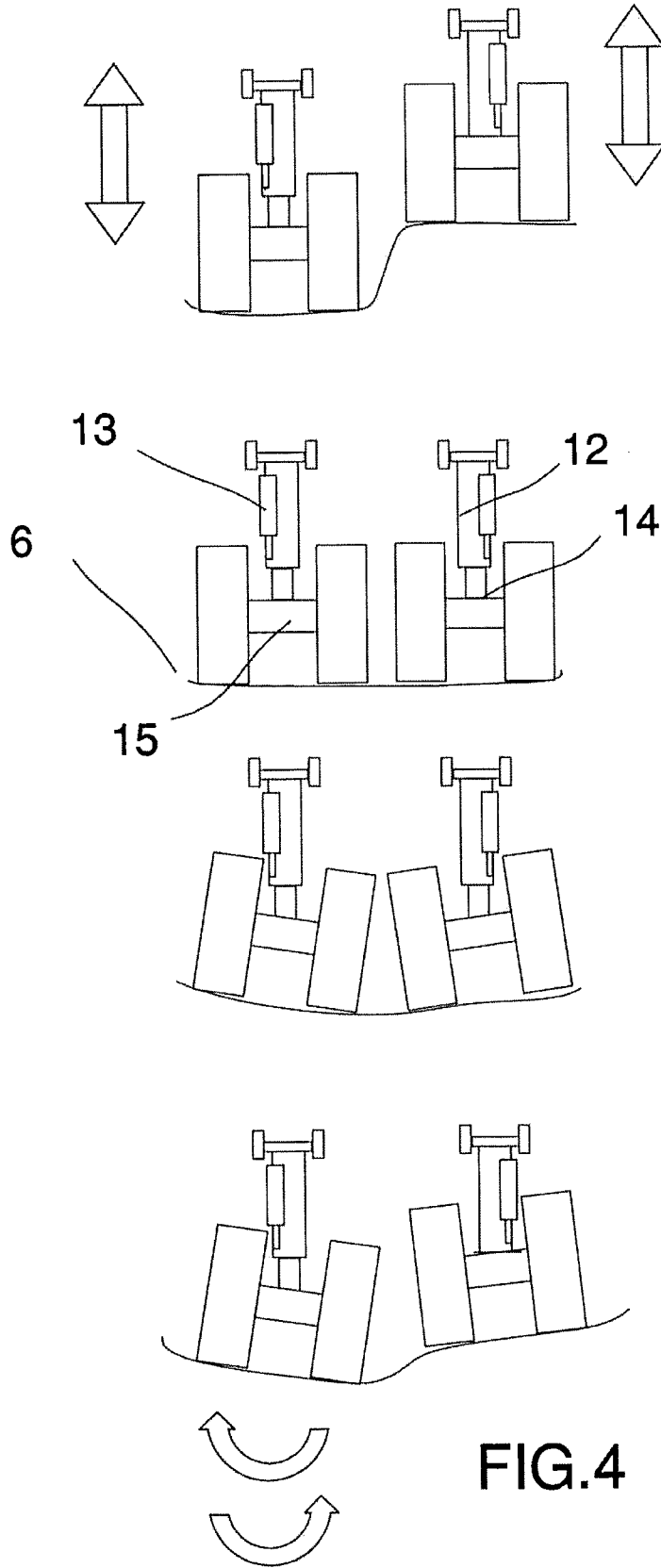

FIG. 3



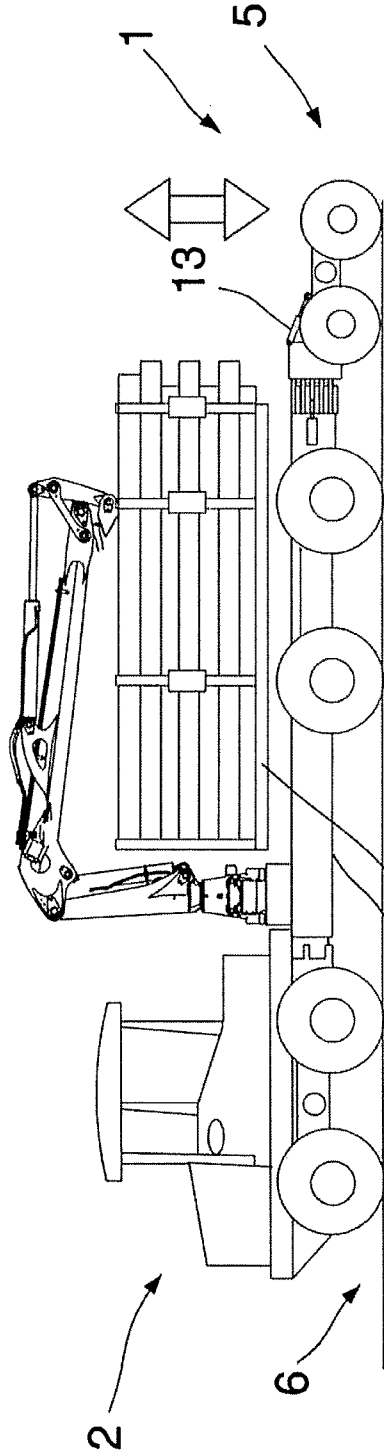

FIG. 5

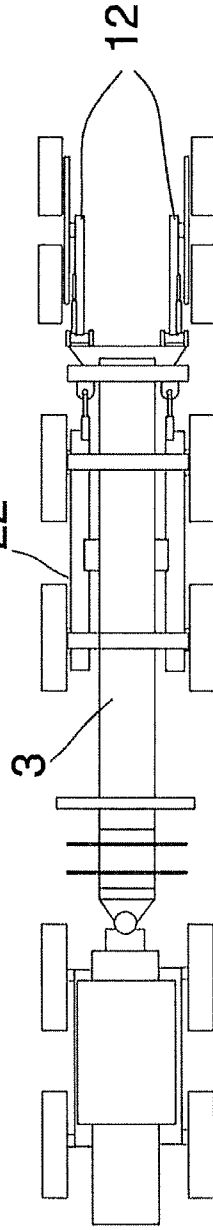

FIG. 6

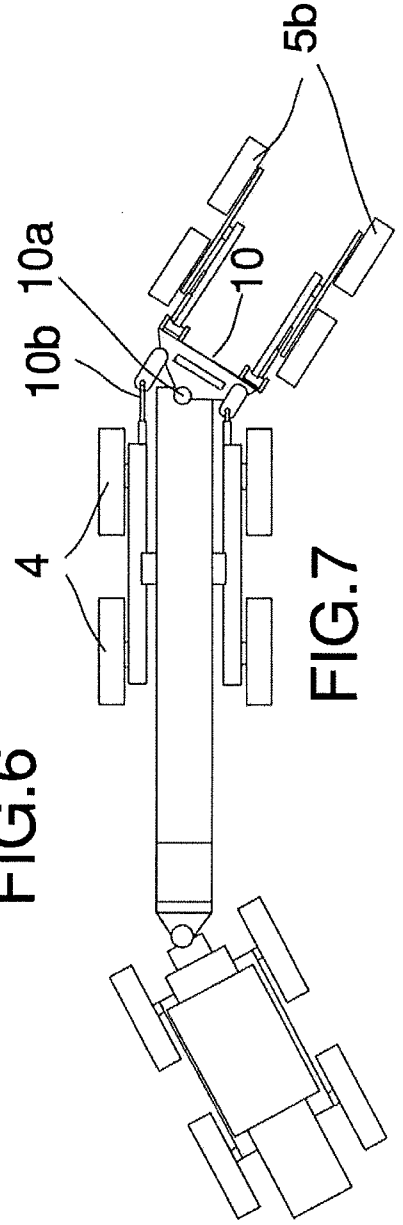
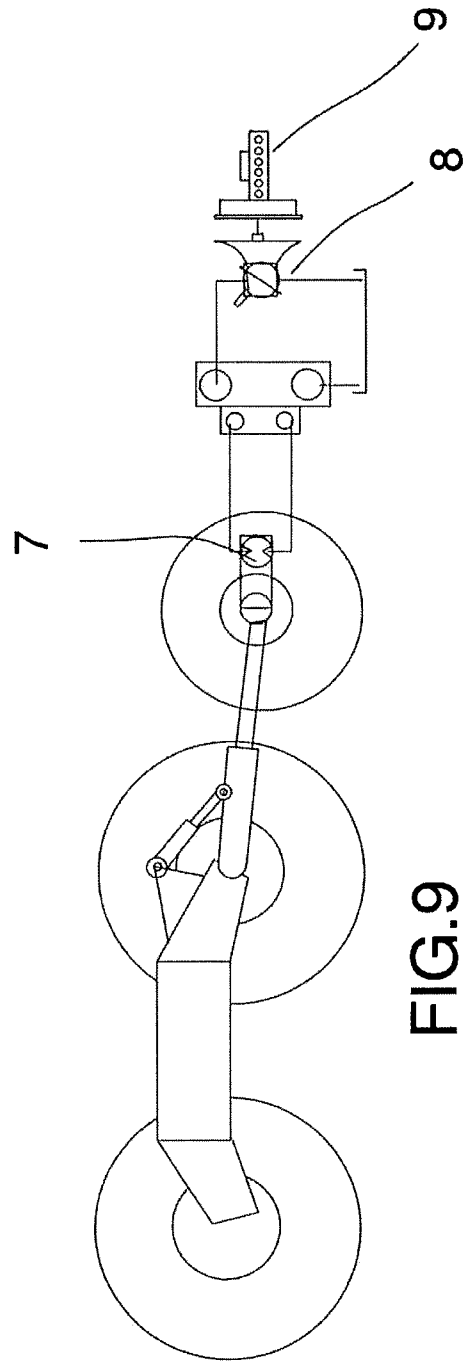
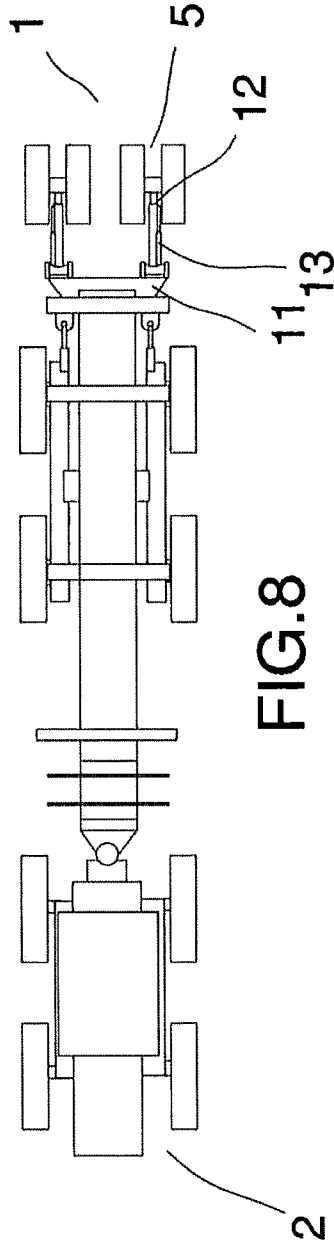

FIG. 7



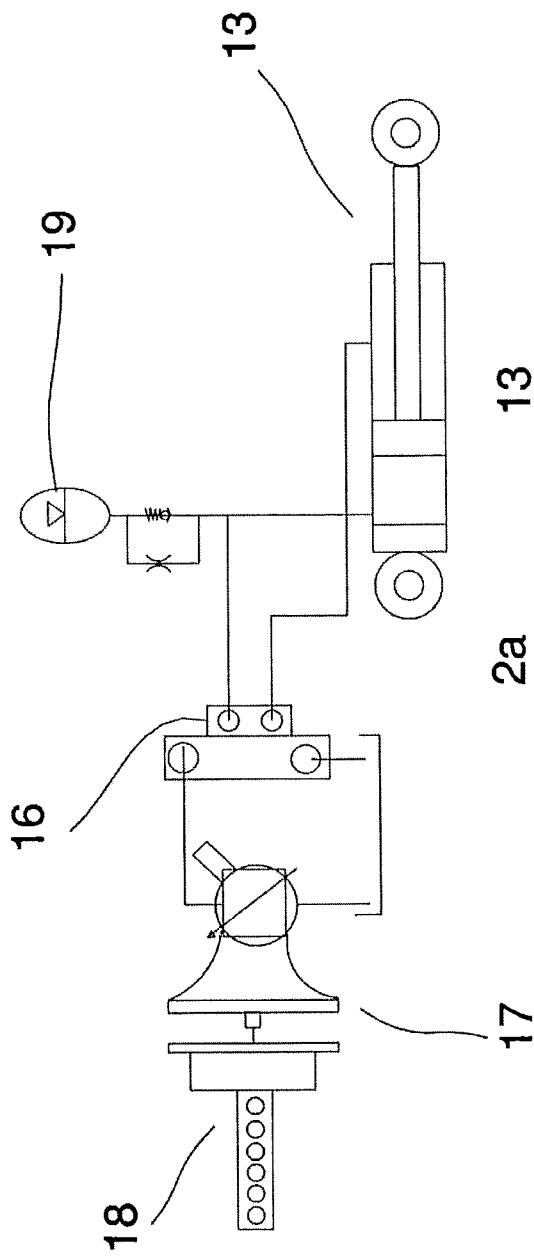

FIG. 10

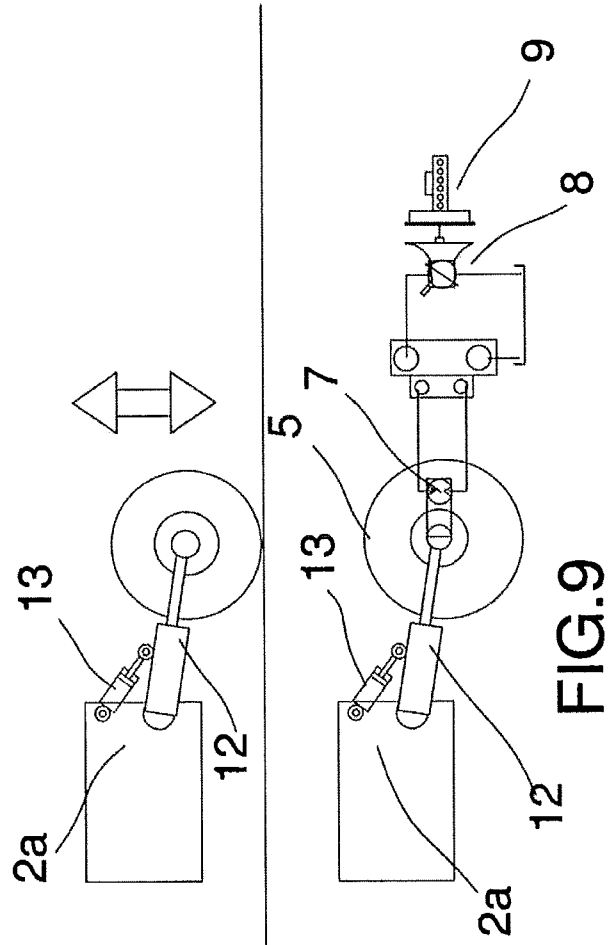

FIG. 9

