



(43) International Publication Date
12 January 2017 (12.01.2017)

- (51) International Patent Classification:
F24J 2/52 (2006.01) F16B 35/06 (2006.01)
- (21) International Application Number:
PCT/EP2016/065196
- (22) International Filing Date:
29 June 2016 (29.06.2016)
- (25) Filing Language: English
- (26) Publication Language: English
- (30) Priority Data:
413011 3 July 2015 (03.07.2015) PL
- (72) Inventor; and
- (71) Applicant : FLOREK, Ryszard [PL/PL]; Losie 11, 33-336 Labowa (PL).
- (74) Agent: BOEHMERT & BOEHMERT ANWALTS-PARTNERSCHAFT MBB; LIESEGANG, Eva, Pettenkofersstraße 20 - 22, 80336 München (DE).
- (81) Designated States (unless otherwise indicated, for every kind of national protection available): AE, AG, AL, AM,

AO, AT, AU, AZ, BA, BB, BG, BH, BN, BR, BW, BY, BZ, CA, CH, CL, CN, CO, CR, CU, CZ, DE, DK, DM, DO, DZ, EC, EE, EG, ES, FI, GB, GD, GE, GH, GM, GT, HN, HR, HU, ID, IL, IN, IR, IS, JP, KE, KG, KN, KP, KR, KZ, LA, LC, LK, LR, LS, LU, LY, MA, MD, ME, MG, MK, MN, MW, MX, MY, MZ, NA, NG, NI, NO, NZ, OM, PA, PE, PG, PH, PL, PT, QA, RO, RS, RU, RW, SA, SC, SD, SE, SG, SK, SL, SM, ST, SV, SY, TH, TJ, TM, TN, TR, TT, TZ, UA, UG, US, UZ, VC, VN, ZA, ZM, ZW.

(84) Designated States (unless otherwise indicated, for every kind of regional protection available): ARIPO (BW, GH, GM, KE, LR, LS, MW, MZ, NA, RW, SD, SL, ST, SZ, TZ, UG, ZM, ZW), Eurasian (AM, AZ, BY, KG, KZ, RU, TJ, TM), European (AL, AT, BE, BG, CH, CY, CZ, DE, DK, EE, ES, FI, FR, GB, GR, HR, HU, IE, IS, IT, LT, LU, LV, MC, MK, MT, NL, NO, PL, PT, RO, RS, SE, SI, SK, SM, TR), OAPI (BF, BJ, CF, CG, CI, CM, GA, GN, GQ, GW, KM, ML, MR, NE, SN, TD, TG).

Published:

— with international search report (Art. 21(3))

(54) Title: MOUNTING METHOD OF CHAMBER PROFILE USING A BRACKET SCREW

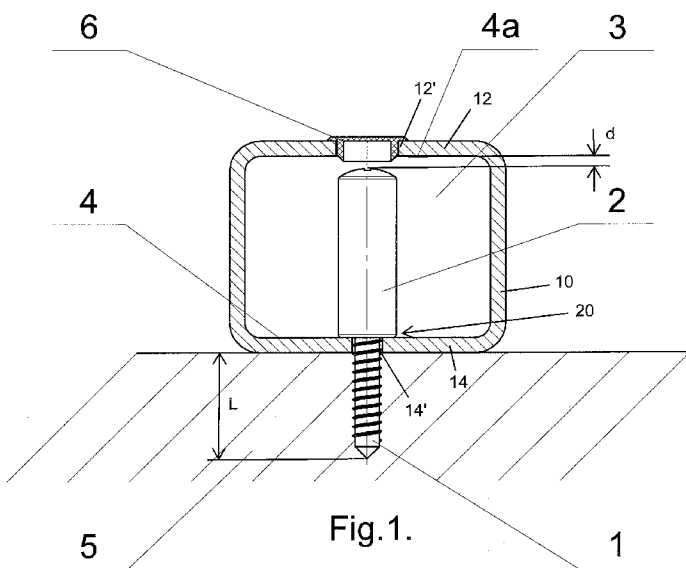

Fig. 1.

(57) Abstract: Mounting method relating to a chamber profile (10) mounted on a stationary component (5) using a screw (20), wherein the threaded portion (1) of the screw (20) is shorter than or of the same length as the sum of heights of all chambers (3) and thicknesses of profile (10) internal walls through which the screw (20) passes, whereas the height of the head (2) has a suitable dimension so that its distance from the nearest internal surface (4a) of the profile wall through which the screw head (2) passes is shorter than the length of the threaded portion screwed in the stationary component (5), so that during installation and dismantling of the profile the screw rests on at least two profile walls.

WO 2017/005580 A1

Mounting Method and Mounting Kit for Mounting a Chamber Profile

[001] The invention relates to a mounting method for mounting a chamber profile to a stationary or non-stationary component using a screw. According to the present solution, the screw is specially designed to eliminate problems associated with installation of chamber profiles, in particular during installation in places which are difficult to reach, like mounting guides of screening element on window frame.

[002] Solutions for fixing chamber profiles using screws, the length of which is shorter than the height of the profile chamber so that the screw is hidden within the profile after mounting, are known. In these cases, special attention must be paid by the installer; otherwise, screws can fall inside the profile, which requires using another screw. If the screw length is similar to the height of the profile chamber, or the distance between inner walls of the profile, the screw can jam inside the profile chamber between two inner walls, and then the jammed screw may block the position where another screw should be mounted. The profile hence cannot be fixed properly.

[003] Application No. JP2008115636 A describes a chamber profile, which serves as a frame to mount a photovoltaic panel on a roof. The profile is fixed using a screw, the length of which exceeds the profile height. The screw in its fixed position passes through the entire profile, with the screw head protruding from the profile so that the panel is fixed in an immovable manner on the roof.

[004] The invention relates to a mounting method for mounting a chamber profile to a stationary component using a screw, and to a corresponding mounting kit. The screw comprises a threaded portion and a head, wherein the threaded portion is shorter than or of the same length as the sum of heights of all chambers and thicknesses of profile walls through which the screw passes. The screw may be shorter than the distance between the outer surfaces of opposing walls through which the screw passes. The height of the head is dimensioned so that, when the screw is inserted into the profile from one side thereof and the threaded portion protrudes from the profile for engagement with the component at the opposite side, the head's distance from the nearest internal surface of the profile wall through which the screw head passes is shorter than the length of the threaded portion protruding from the profile and screwed in the stationary component, so that during installation and dismantling of the profile, the screw always rests on at least two

profile walls. In the mounted position, the screw's head is fully received within the profile.

[005] The height of the profile chamber is defined as the distance between opposing internal surfaces of profile walls, measured in parallel to the direction of the screw which can be orthogonal to the surface of the stationary component. In order to mount the profile, it is fixed in an immovable manner at the stationary component by means of the screw. Then the profile is in its fixed position, or fully mounted position.

[006] The screw head, when the profile is fully mounted to the stationary component, abuts or adjoins the internal surface of the profile wall through which the threaded portion protrudes, rests on this surface and is completely embedded inside the profile, whereas the threaded portion in the screw's fully mounted position protrudes from the profile to be at least partially embedded in the stationary component, to the extent sufficient to fix the profile in an immovable manner. The screw head can be a monolithic component, or a screw head combined with a sleeve of predetermined length into which is inserted a standard off-the-shelf screw, wherein the screw head and the sleeve can be fixed to each other or combined otherwise to form a head part according to the invention.

[007] The invention is applied to mounting a chamber profile using a screw comprising a threaded portion and a head to fix the chamber profile, having one of more chambers, such as two or three chambers, to a stationary or non-stationary component.

[008] Advantageous effects of the solution are that mounting of the profile with a screw eliminates problems associated with installation of chamber profiles, in particular during installation in places which are difficult to reach. During profile mounting, the screw cannot fall inside the profile, nor can it jam inside the chamber as the screw during mounting in any position rests on at least two profile walls, in particular two opposing profile walls through which the screw is inserted. After mounting, the screw head is completely hidden in the profile chamber. A cap can be provided in the profile opening through which the screw is inserted, which seals the interior of the profile chamber and provides for aesthetic appearance of the profile in its fixed position.

[009] Examples of the invention are described with reference to the drawings in which:

[0010] Fig. 1 – shows a single-chamber profile fixed to a stationary component using a monolithic screw.

[0011] Fig. 2 – shows a double-chamber profile fixed to a stationary component using a standard screw with a sleeve to form the screw head.

[0012] Of course, the two examples can be combined, and the profile is not limited to any

numbers of chambers nor to any particular shape.

[0013] First example

[0014] According to the first embodiment, a kit is provided comprising a single-chamber profile 10 and a screw 20. The screw 20 comprises a threaded portion 1 and a head 2 which are integrally formed. The profile 10, in the example shown, has a square or rectangular cross section but it is not limited to any specific cross section. It has two opposing walls 12, 14, each wall having an opening 12', 14' for receiving the screw 20. The screw is inserted into the profile 10 through opening 12' and travels through the profile to opening 14' where it exits, or extends from, to engage a component to which the profile is to be fixed. In the context of this application, wall 12 is designated as top wall and wall 14 is designated as bottom wall.

[0015] The screw 20 is dimensioned such that the threaded portion 1 of the screw, in its fully inserted and hence most extended position, for fixing the profile to the stationary component 5, extends sufficiently far to be screwed into the stationary or another component 5 using, for example, a drill - driver, so that the profile is fixed in an immovable manner. The screw head 2 is dimensioned relative to the profile such that, in the fully mounted position, it is completely received in the profile chamber 3, defined between top and bottom walls 12, 14, and adjoins the profile internal surface 4 of bottom wall 14 through which the threaded portion 1 passes. In this fully mounted position, the distance d of the head 2 from the nearest internal surface 4a of the profile wall 12 through which the screw head enters and passes is shorter than the length L of the threaded portion 1 extending from the profile and screwed in the stationary or other component 5; i.e. $d < L$. Further, preferably, $d < L/2$ or even $d < L/3$ or $d < L/4$, $d < L/5$, $d < L/10$, and $d \geq 0$. As an example: d is about $L/10$ or about 1-10 mm or about 2-5 mm. In this and other examples, L is about 5-50 mm, and the height of the head is about 10-50 mm but will, of course, depend on the size of the profile and the needs of the mounting environment.

[0016] The relative sizes have the effect that, when inserting the screw 1 into the profile 12, as soon as the threaded portion engages the opening 14', the head 2 is still guided by the walls of the opening 12', and it continues to be guided through at least part of the threading operation, until the threaded portion reaches a stable fit with the receiving component. Once the screw 1 is fully mounted, the screw head 2 rests on the inner wall surface of the bottom wall 14, adjacent to the opening 14'. In the example, the screw head is of cylindrical shape, and the diameter of the opening 12' in upper wall 12 is little larger than the diameter of the screw head 2, so that the screw head is guided in the opening without creating any substantial friction or interference. The diameter of the opening 14' in bottom wall 14 is little larger than the diameter

of the threaded portion so that also the threaded portion 14' is guided by the walls of the opening 14' during mounting thereof. The screw head 2 can have a different shape, such as a conical shape or any other longitudinal shape which allows guiding the screw head 2 within opening 12' during mounting of the profile 10.

[0017] Optionally, there can be a cap 6 to be inserted in the profile opening 12' through which the screw 1 is inserted. The 6 seals the opening 12' and provides for more aesthetic appearance of the profile after mounting.

[0018] Second example

[0019] According to the second example, a double-chamber profile 30 is provided, having a first chamber 3' and a second chamber 3''. Openings 32', 34', 36' are provided in a top wall 32, a bottom wall 34 and an intermediate wall 36. The openings are aligned and are dimensioned to receive a screw 40, wherein the opening 32' in the top wall 32 is dimensioned to let the screw head 42 pass there through, and the openings 34', 36' are dimensioned to let the threaded portion 44 of the screw 40 pass there through. Concerning the dimensions of the screw and the opening reference is made to the description of figure 1.

[0020] The screw can be an off the shelf screw having a short flat or rounded screw head 42. The screw head 42 is combined with a sleeve 2' wherein sleeve is dimensioned to also pass through the top opening 32' but not through the intermediate opening 36'. The sleeve 2' can be fixed to the screw head 42 or can be loosely fitted around the threaded portion of the screw adjacent to the head. 42. In the position, where the screw is fully mounted in the profile 30, it is embedded in the first chamber 3' and the sleeve adjoins the internal surface 4' of the wall 36 separating the two adjacent chambers 3', 3''.

[0021] In this position, the distance d of the head 42 to the nearest internal surface 4'' of the profile wall 32, through which the screw head is inserted, is shorter than the length L of the threaded portion 44 of the screw 40 extending from the bottom opening 34' and available for being screwed into the component 5'. The relative dimensions of the distance d and extending length L can be similar or the same as described above with reference to figure 1; i.e. $d < L$. Further, preferably, $d < L/2$ or even $d < L/3$ or $d < L/4$, $d < L/5$, $d < L/10$, and $d \geq 0$. As an example: d is about $L/10$ or about 1-10 mm or about 2-5 mm. L can be about 5-50 mm, and the length of the sleeve 2' can be about 10-50 mm but will, of course depend of the size of the profile and the needs of the mounting environment.

[0022] Due to the sleeve 2', the screw is guided along the inner walls of the upper opening 32' during mounting while it proceeds to extend from the lower opening 34' and is screw into the

component 5'. In its fully mounted position, the distance d of the head 42 from the nearest internal surface 4'' of the profile wall 32 through which the screw head enters and passes is shorter than the length L of the threaded portion 1' extending from the profile and screwed in the stationary

[0023] There is an optional cap 6' to be inserted in the profile opening 32' through which the screw is inserted. The cap can seal the opening and provide for a more aesthetic appearance.

[0024] The treaded portion 44 of the screw traverses the lower profile chamber 3'' to extend from the bottom wall 34 so that the profile can be fixed in an immovable manner to the stationary or another component 5'.

CLAIMS

1. A mounting kit comprising a chamber profile and a screw, the screw having a threaded portion and a head, wherein the chamber profile comprises at least one chamber having a top wall and a bottom wall, the top and bottom walls having aligned openings for receiving the screw,
wherein the threaded portion of the screw is shorter than or of the same length as the sum of heights of all chambers and thicknesses of profile walls through which the screw passes,

wherein, in the fully mounted position, the screw head is located inside the profile, with at least part of the threaded portion extending from the bottom wall, and the screw head is located at a position so that its distance from the nearest internal surface of the profile wall through which the screw head passes is shorter than the length of the threaded portion extending from the profile.
2. The kit according to claim 1, characterised in that the screw and the openings in the profile top and bottom walls are dimensioned such that, during mounting and dismantling of the chamber profile the screw rests on at least two profile walls.
3. The kit according to claim 1 or claim 2, characterised in that the head of the screw is dimensioned so that, in the fully mounted position, the screw head rests on one of the internal surfaces of the profile.
4. The kit according to one of the preceding claims, characterised in that the screw head and the threaded portion create a monolithic component.
5. The kit according to one of the preceding claims, characterised in that the screw head is in the shape of a cylinder.

6. The kit according to one of preceding claims, characterised in that the screw head is associated with a sleeve surrounding part of the threaded portion adjacent to the screw head.
7. The kit according to one of the preceding claims, characterised in that the screw is an off-the-shelf screw and is combined with a sleeve, which forms integral part with screw, so that the screw head in combination with the sleeves forms a cylindrical body.
8. A method of mounting a chamber profile to a component using a screw, the screw comprising a threaded portion and a head, and the chamber profile comprising at least one chamber having a top wall and the bottom wall, the top and bottom walls having aligned openings for receiving the screw, wherein the threaded portion of the screw is shorter than or of the same length as the sum of heights of all chambers and thicknesses of profile walls through which the screw passes, characterised in that the screw is inserted into the profile through the opening in the top wall and through the profile so that the threaded portion extends from the opening in the bottom wall, wherein during mounting of the chamber profile the screw is guided by at least two profile walls.
9. The method of claim 8, characterized in that, during mounting of the chamber profile, the screw is guided by the inner edges of the openings in the top and bottom walls of the chamber profile.
10. The method of claim 8 or 9 characterized in that, in the fully mounted position, the height of the screw head is spaced from the nearest internal surface of the top wall through which the screw head passes by a distance smaller than the length of the threaded portion extending from the bottom wall.
11. The method of one of claims 8 to 10, characterized in that, in the fully mounted position, the head of the screw is received within the chamber profile, with no part of the head extending therefrom.
12. The method according to one of claims 8 to 11, characterised in that, in the fully mounted position, the head of the screw adjoins one of the internal surfaces of the profile.

13. The method according to one of claims 8 to 12, characterised in that, and the fully mounted position, the threaded portion of the screw extending from the bottom wall of the chamber profile is at least partially embedded inside the component.
14. The method according to one of claims 8 to 13, characterised in that the screw head (2) and the threaded portion (1) create a monolithic component.
15. The method according to one of claims 8 to 14, characterised in that the screw is an off-the-shelf screw combined with a sleeve, which forms integral part with screw, to form a cylindrical screw head.

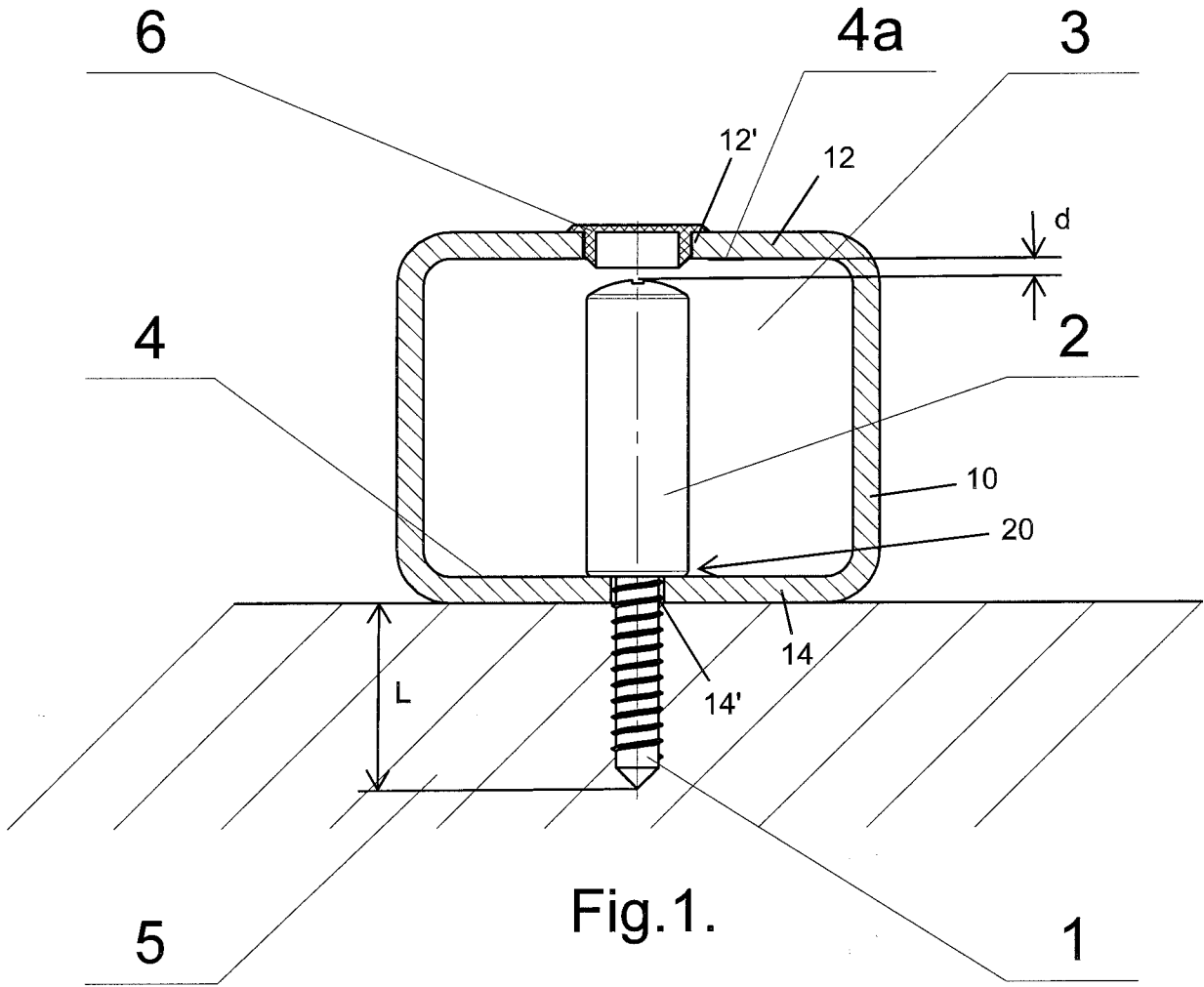

Fig.1.

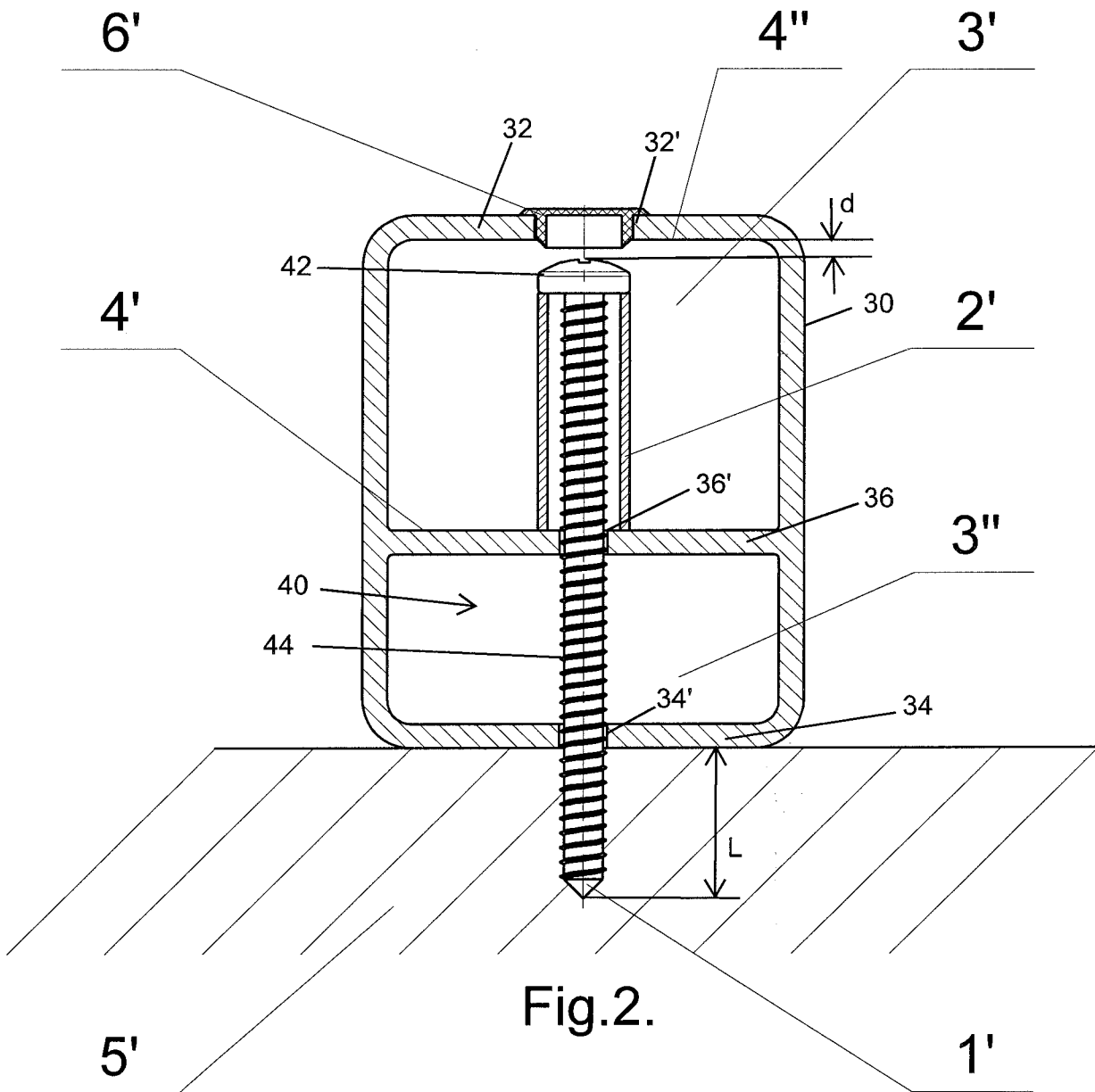

Fig.2.

INTERNATIONAL SEARCH REPORT

International application No
PCT/EP2016/065196

A. CLASSIFICATION OF SUBJECT MATTER
 INV. F24J2/52 F16B35/06
 ADD.
 According to International Patent Classification (IPC) or to both national classification and IPC

B. FIELDS SEARCHED
 Minimum documentation searched (classification system followed by classification symbols)
 F24J F16B

Documentation searched other than minimum documentation to the extent that such documents are included in the fields searched

Electronic data base consulted during the international search (name of data base and, where practicable, search terms used)
 EPO-Internal, WPI Data

C. DOCUMENTS CONSIDERED TO BE RELEVANT

| Category* | Citation of document, with indication, where appropriate, of the relevant passages | Relevant to claim No. |
|-----------|---|-----------------------|
| X | DE 299 03 930 U1 (ARGAUER EDGAR [DE]) 10 June 1999 (1999-06-10) figures 1, 2 page 6, line 9 - line 11 ----- | 1-15 |
| A | US 2012/180406 A1 (KOBAYASHI SHUICHI [JP]) 19 July 2012 (2012-07-19) figures 4, 5A ----- | 1-15 |
| A | US 5 964 165 A (SCHMIDT MARKUS [DE] ET AL) 12 October 1999 (1999-10-12) figures 3-5 ----- | 1-15 |

Further documents are listed in the continuation of Box C.

See patent family annex.

* Special categories of cited documents :

- "A" document defining the general state of the art which is not considered to be of particular relevance
- "E" earlier application or patent but published on or after the international filing date
- "L" document which may throw doubts on priority claim(s) or which is cited to establish the publication date of another citation or other special reason (as specified)
- "O" document referring to an oral disclosure, use, exhibition or other means
- "P" document published prior to the international filing date but later than the priority date claimed

- "T" later document published after the international filing date or priority date and not in conflict with the application but cited to understand the principle or theory underlying the invention
- "X" document of particular relevance; the claimed invention cannot be considered novel or cannot be considered to involve an inventive step when the document is taken alone
- "Y" document of particular relevance; the claimed invention cannot be considered to involve an inventive step when the document is combined with one or more other such documents, such combination being obvious to a person skilled in the art
- "&" document member of the same patent family

Date of the actual completion of the international search

21 September 2016

Date of mailing of the international search report

04/10/2016

Name and mailing address of the ISA/

European Patent Office, P.B. 5818 Patentlaan 2
 NL - 2280 HV Rijswijk
 Tel. (+31-70) 340-2040,
 Fax: (+31-70) 340-3016

Authorized officer

Fernandez Ambres, A

INTERNATIONAL SEARCH REPORT

Information on patent family members

International application No

PCT/EP2016/065196

| Patent document cited in search report | Publication date | Patent family member(s) | Publication date |
|--|------------------|-------------------------|-----------------------------|
| DE 29903930 | U1 | 10-06-1999 | NONE |
| ----- | | | |
| US 2012180406 | A1 | 19-07-2012 | AU 2009357024 A1 19-07-2012 |
| | | | CN 102667028 A 12-09-2012 |
| | | | EP 2518235 A1 31-10-2012 |
| | | | JP 5414783 B2 12-02-2014 |
| | | | KR 20120110104 A 09-10-2012 |
| | | | US 2012180406 A1 19-07-2012 |
| | | | WO 2011077538 A1 30-06-2011 |
| ----- | | | |
| US 5964165 | A | 12-10-1999 | AT 191169 T 15-04-2000 |
| | | | BR 9703869 A 27-10-1998 |
| | | | CN 1174111 A 25-02-1998 |
| | | | DE 29611613 U1 05-09-1996 |
| | | | EP 0816019 A1 07-01-1998 |
| | | | HU 9701042 A1 28-01-1998 |
| | | | US 5964165 A 12-10-1999 |
| ----- | | | |