



US 20090038594A1

(19) **United States**  
(12) **Patent Application Publication**  
**Naquin**

(10) **Pub. No.: US 2009/0038594 A1**  
(43) **Pub. Date: Feb. 12, 2009**

(54) **PISTONS**

(60) Provisional application No. 60/709,942, filed on Aug. 18, 2005.

(76) Inventor: **Randolph Naquin**, Des Allemands, LA (US)

**Publication Classification**

Correspondence Address:  
**Randolph Naquin**  
116 Pleasant Valley Street  
Des Allemands, LA 70030 (US)

(51) **Int. Cl.**  
*F02B 23/00* (2006.01)  
*F02F 3/00* (2006.01)

(52) **U.S. Cl.** ..... **123/661; 123/193.6**

(21) Appl. No.: **12/246,502**

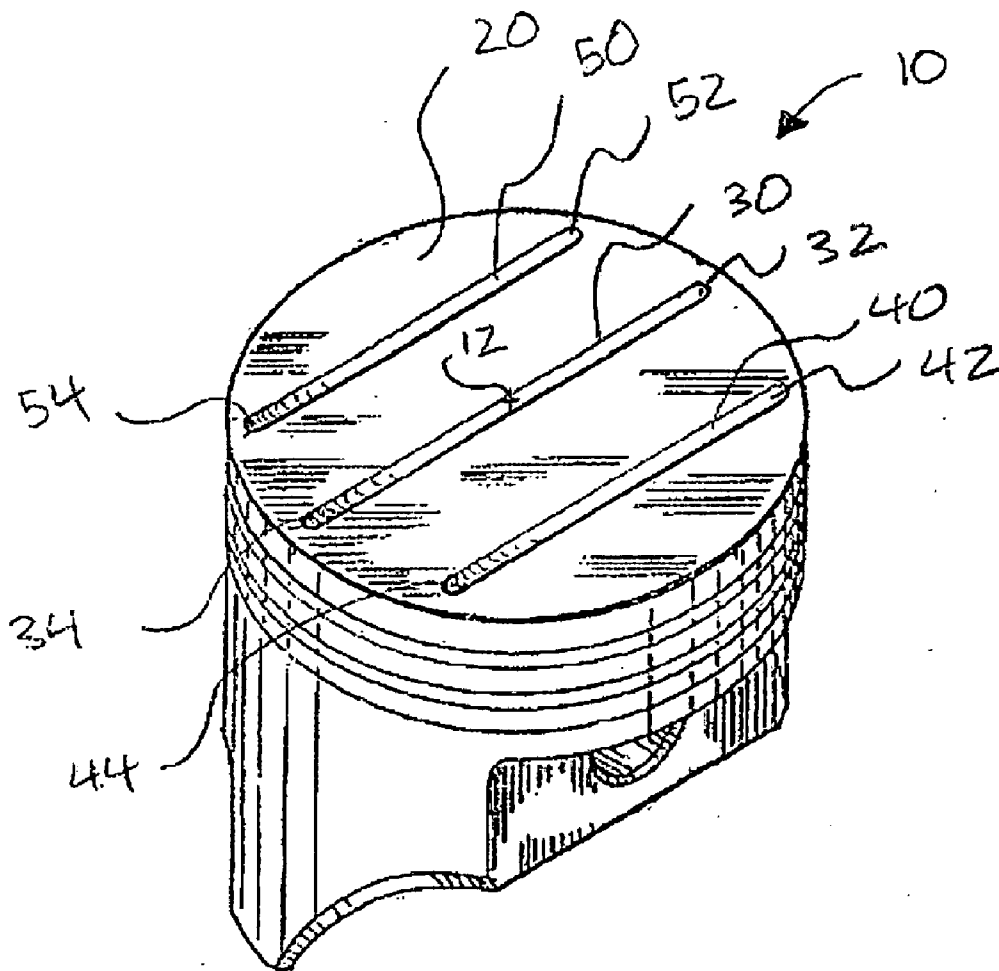
(57) **ABSTRACT**

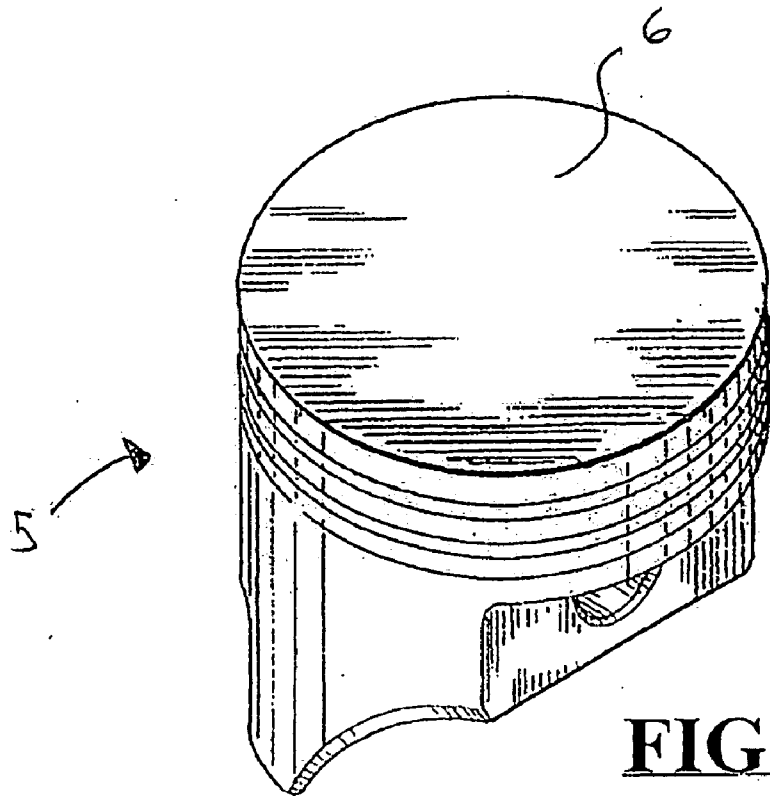
(22) Filed: **Oct. 7, 2008**

**Related U.S. Application Data**

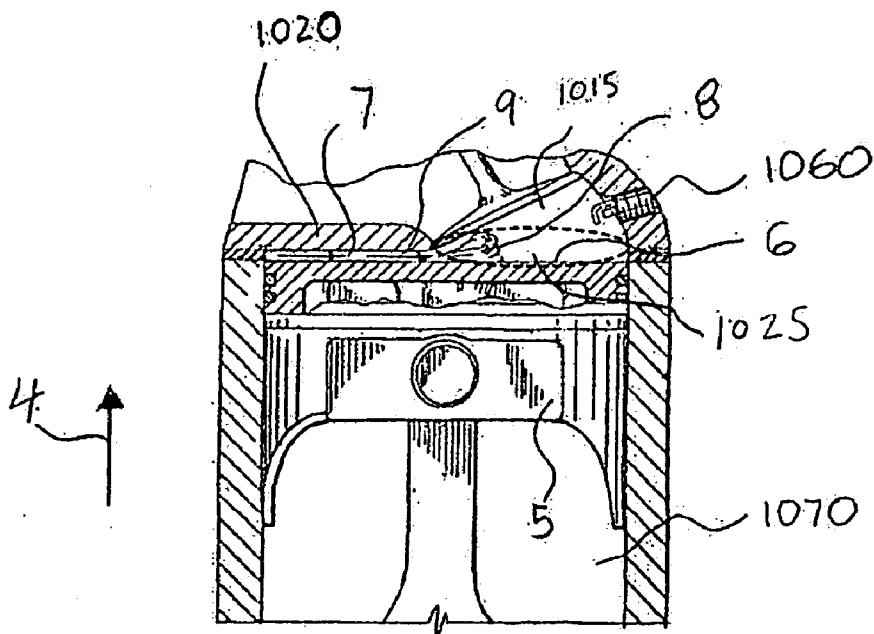
(63) Continuation of application No. 11/463,405, filed on Aug. 9, 2006, now abandoned.

An improved internal combustion engine is provided with at least one channel or groove on its compression face. The at least one channel or groove can be open and of uniform width. The channel or groove can direct flow of an air-fuel mixture to increase combustion efficiency.

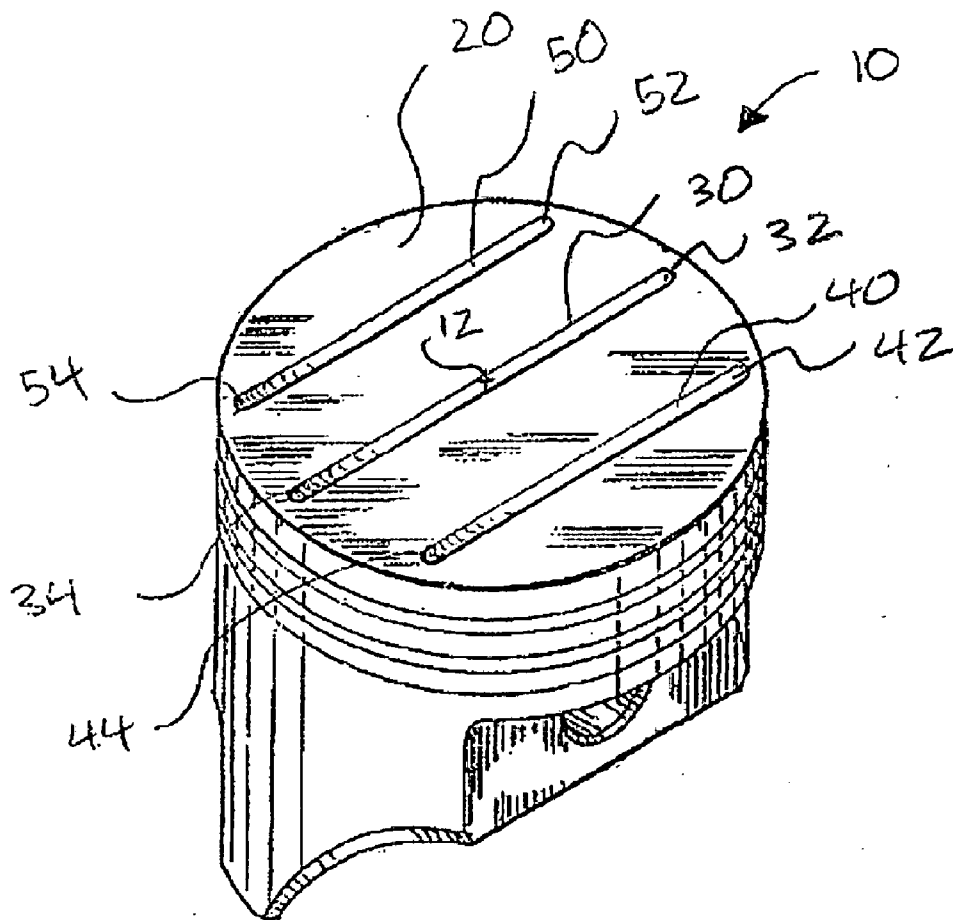




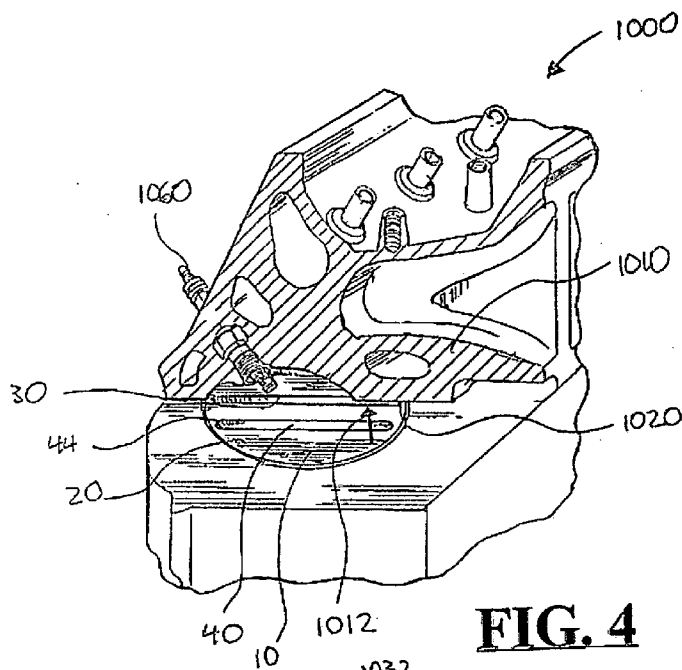
**FIG. 1**  
PRIOR ART



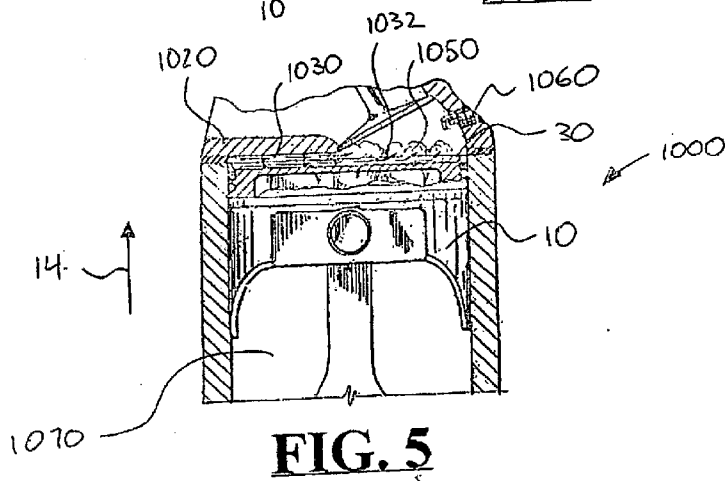
**FIG. 2**  
PRIOR ART



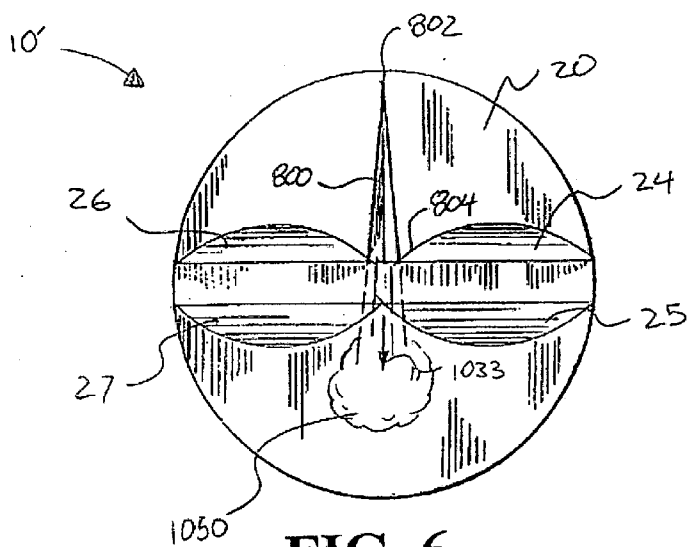
**FIG. 3**



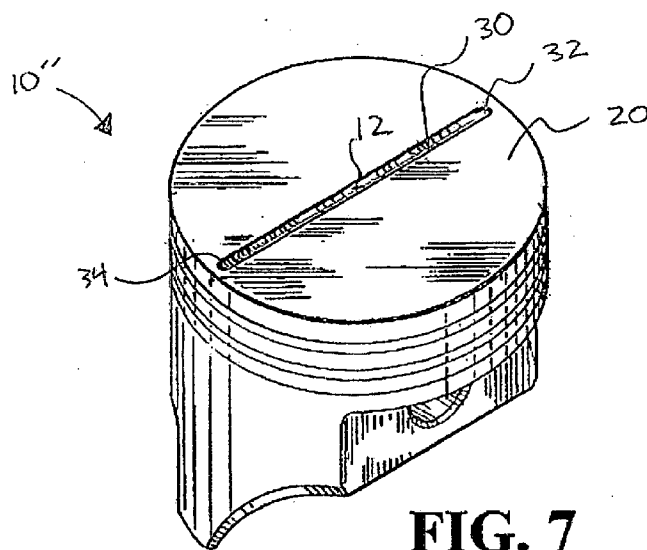
**FIG. 4**



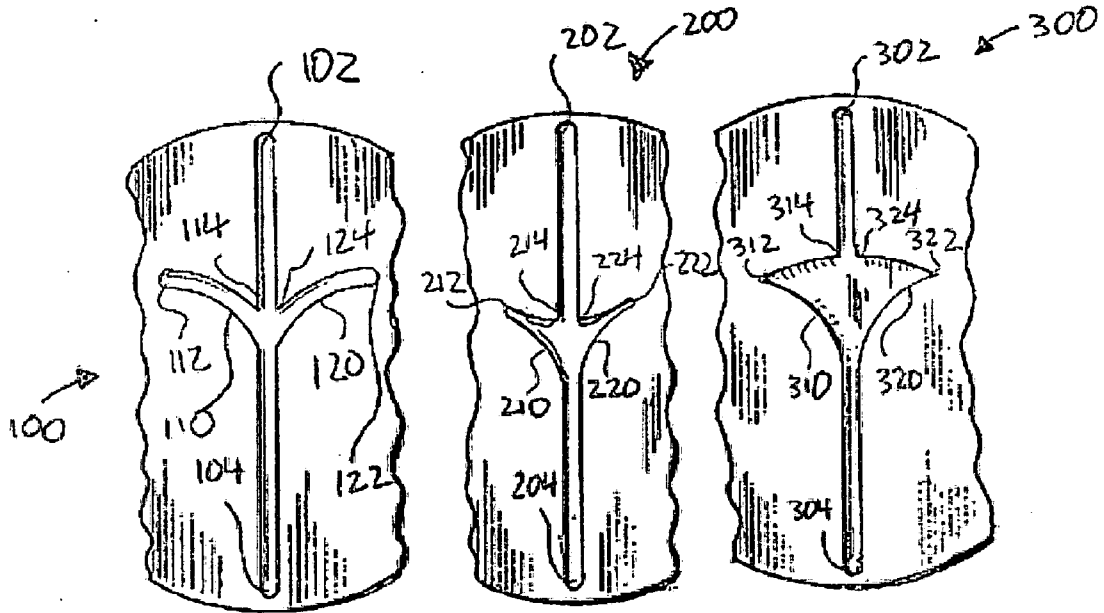
**FIG. 5**



**FIG. 6**



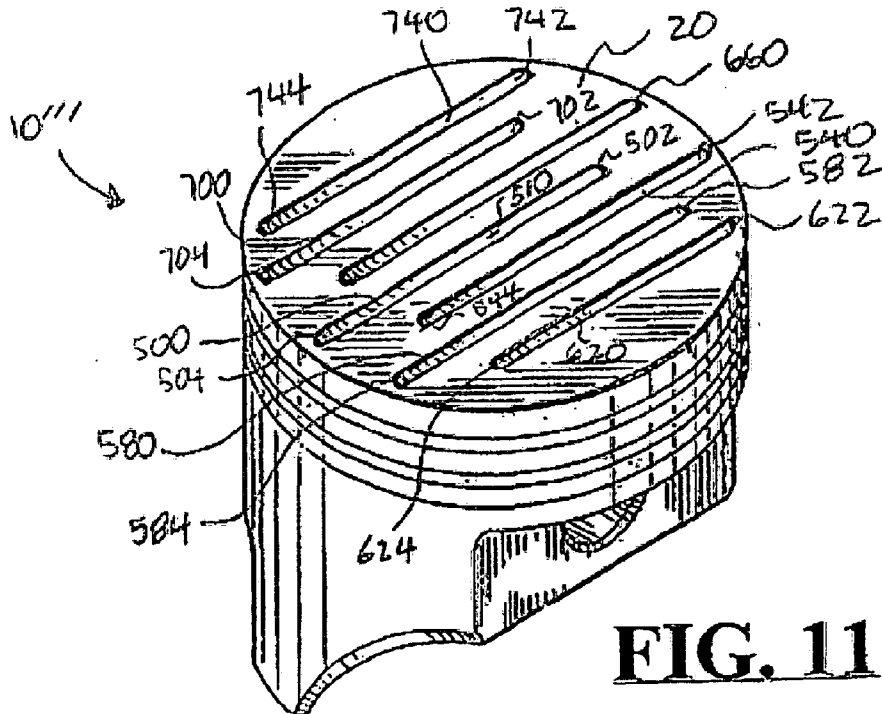
**FIG. 7**



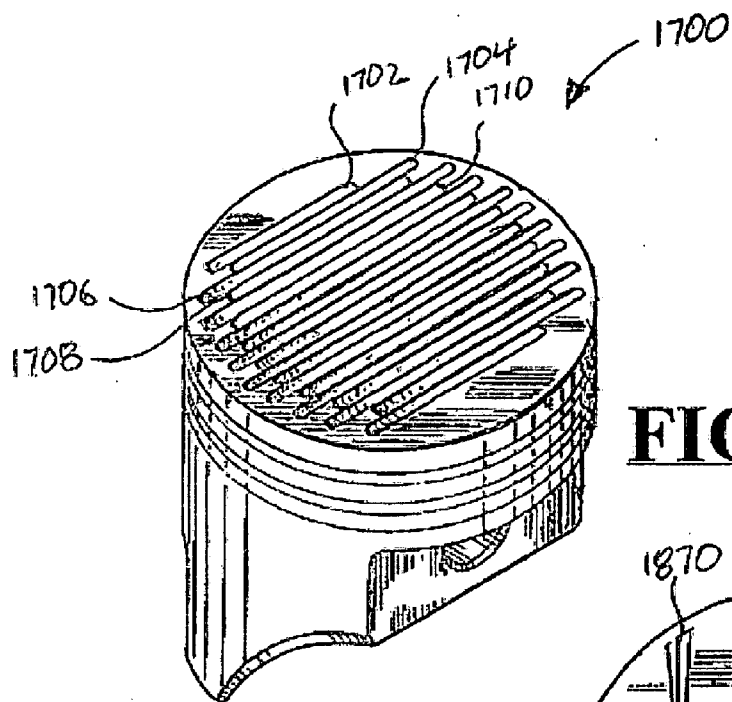
**FIG. 8**

**FIG. 9**

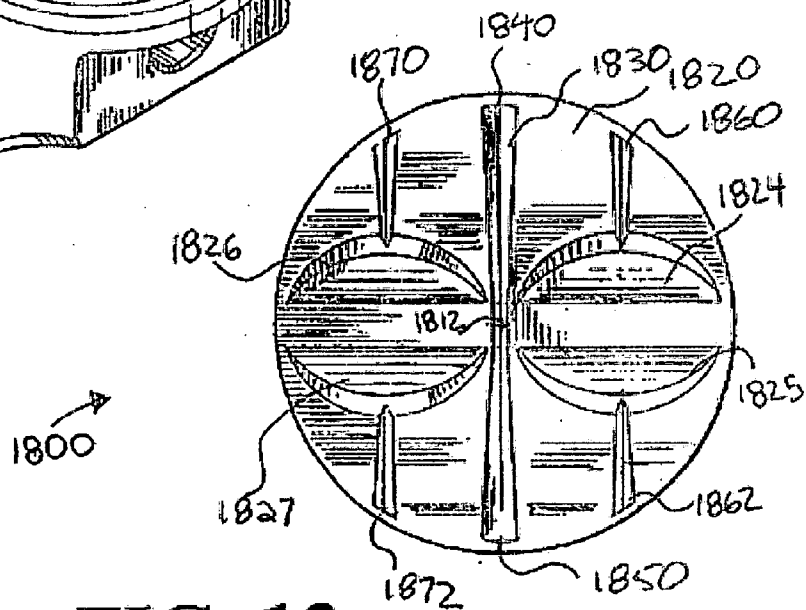
**FIG. 10**



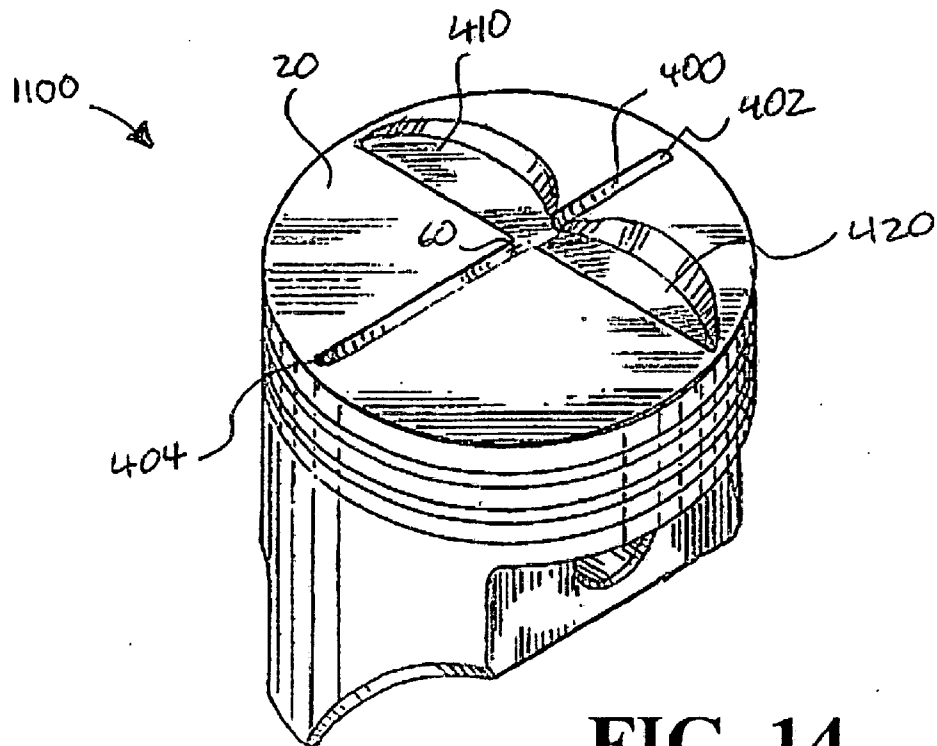
**FIG. 11**



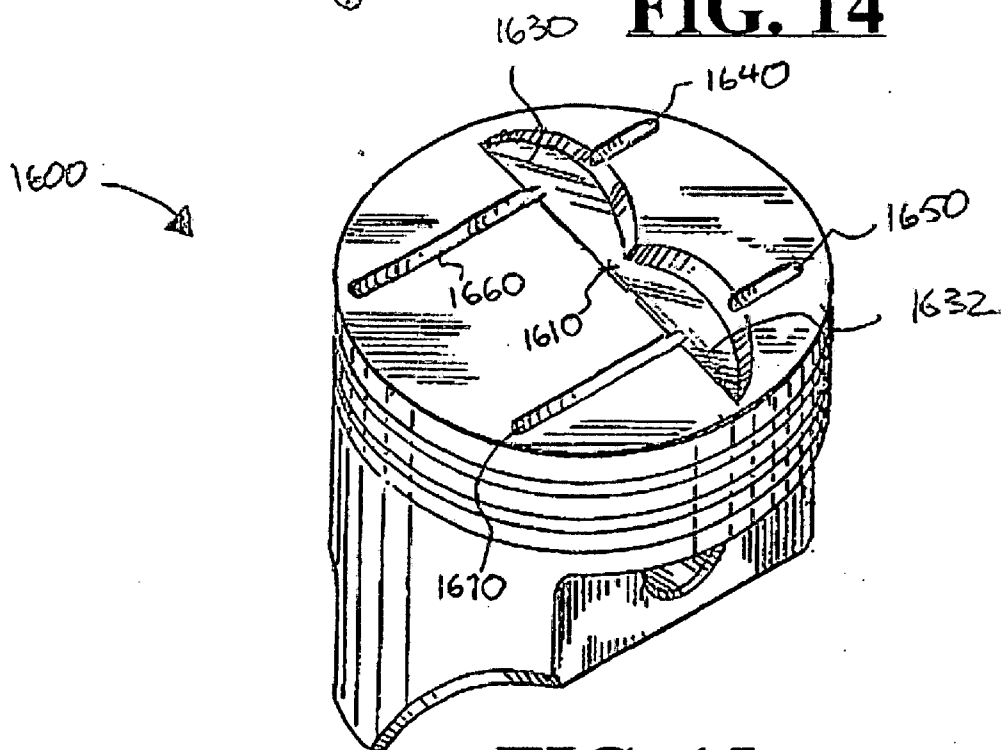
**FIG. 12**



**FIG. 13**

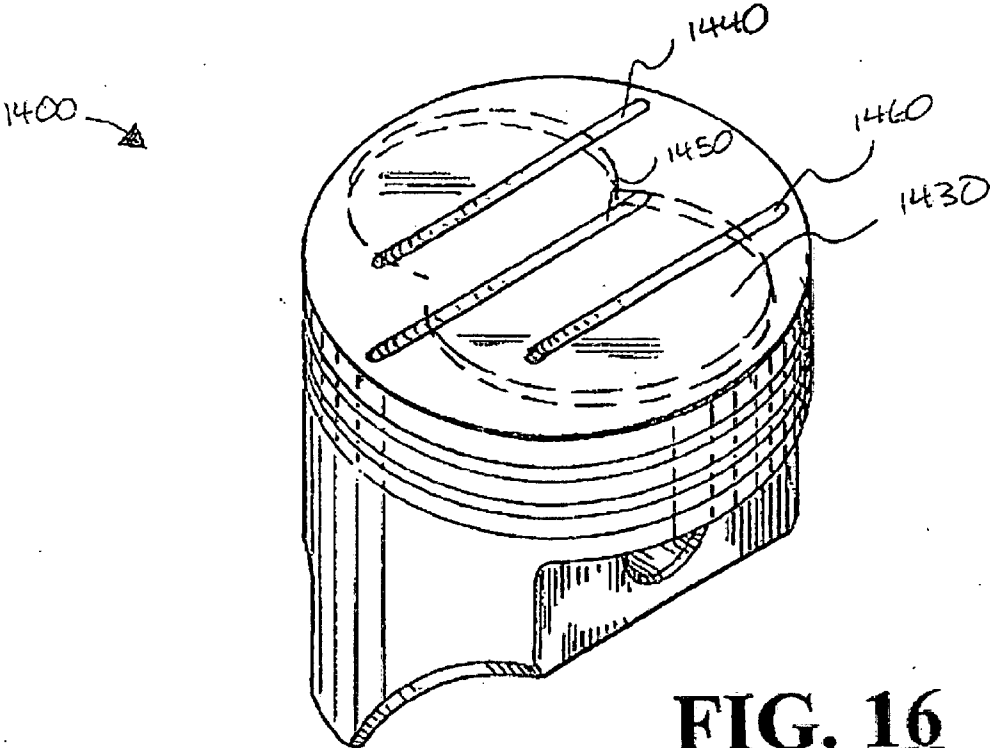


**FIG. 14**

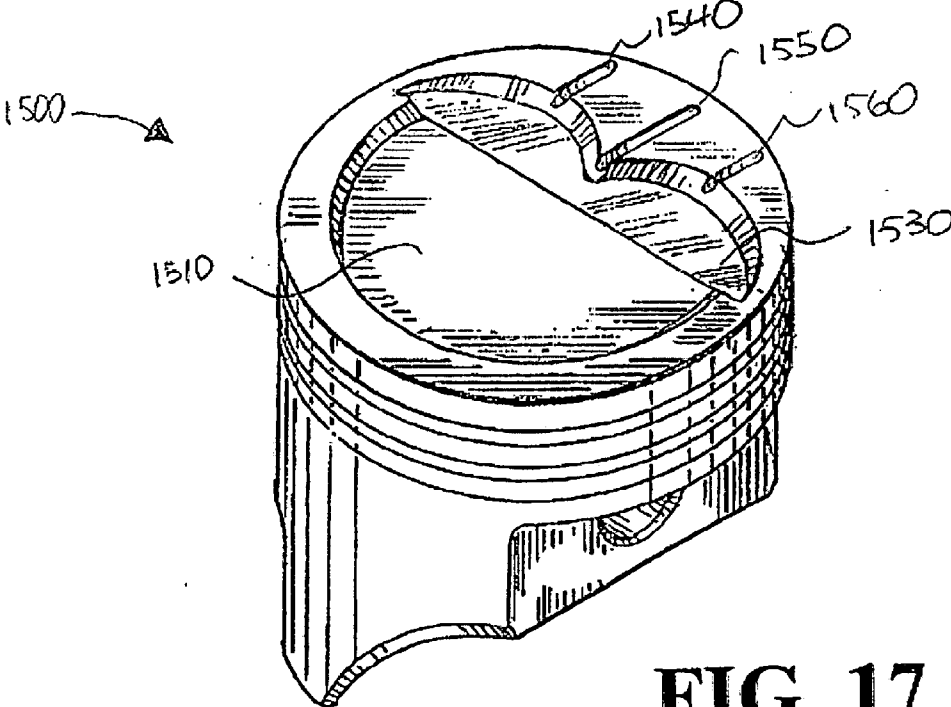


**FIG. 15**

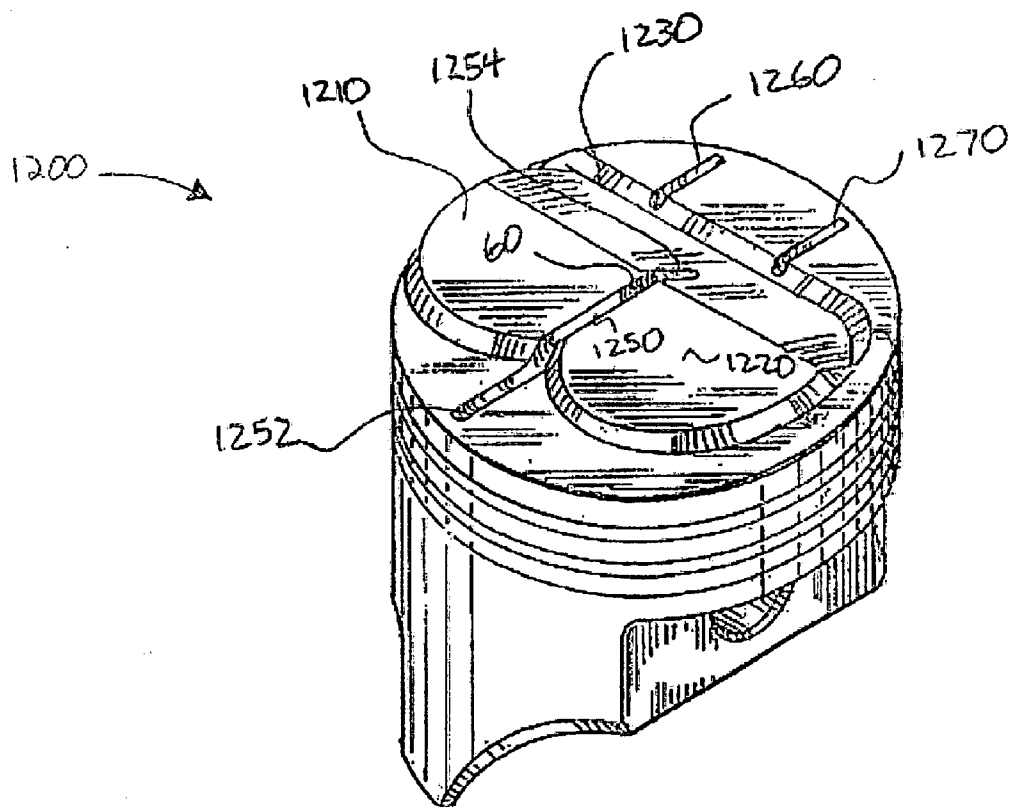




**FIG. 16**



**FIG. 17**



**FIG. 18**

**PISTONS**

**CROSS-REFERENCE TO RELATED APPLICATIONS**

**[0001]** This is a continuation of U.S. patent application Ser. No. 11/463,405 filed Aug. 9, 2006 which claims priority to U.S. Provisional Patent Application Ser. No. 60/709,942, filed Aug. 18, 2005, incorporated herein by reference, is hereby claimed.

**STATEMENT REGARDING FEDERALLY SPONSORED RESEARCH OR DEVELOPMENT**

**[0002]** Not applicable

**REFERENCE TO A "MICROFICHE APPENDIX"**

**[0003]** Not applicable

**BACKGROUND**

**[0004]** The present invention relates to improvements in combustion by enhancing burning in two and four cycle internal combustion engines.

**[0005]** During combustion the air-fuel mixture is drawn into the engine through the intake port due to low pressure created by the descending piston. The controlled air-fuel mixture is compressed by the rising piston to a desirable cylinder pressure. The compressed gases are ignited through a spark plug located in the cylinder head before top dead center (TDC) resulting in a sharp increase in temperature and pressure inside the combustion chamber. The expanding gases push the piston down which turns the crank rolling and storing the energy in a flywheel to do useful work.

**[0006]** Flame velocity and degree of combustion have a direct bearing on power output, efficiency, fuel consumption, emissions, operating temperatures, sound and vibration levels, and reliability. The flame velocity and degree of combustion are related to the state of air-fuel mixture which is ignited by the spark plug.

**[0007]** Four stroke combustion chamber layouts include plain cylindrical form, bath tub type, wedged shape type, and hemispherical cross flow type.

**[0008]** The flat portion of the cylinder head close to the piston crown at top dead center (TDC) is known as the "squish area." Generally, the trapped charge between the piston crown and the squish area nearing TDC is ejected towards the combustion chamber cavity causing turbulence prior to ignition. Higher compression ratios are possible with squish designs resulting in improved engine efficiencies. Turbulence in the charge can be also caused by inlet ports, their shapes, angles and surface finish which help to keep the air-fuel mixture in a homogeneous state at the point of entry only. Multipoint fuel injection basically atomizes fuel particles prior to entry on the intake stroke and achieves better combustion.

**[0009]** One purpose of squish design in internal combustion engines is to convert kinetic energy in the form of fluid flow into turbulent energy. As the piston reaches top dead center of the compression stroke, the air-fuel mixture located between the piston and the head is squished out and flows into the combustion chamber cavity. When the piston displaces the air-fuel mixture; it imparts kinetic energy into the mixture. As the squished air-fuel mixture flows into the combustion chamber cavity, the energy is converted to turbulence. The

effect of the turbulence is to promote mixing of air and fuel into a more homogeneous mixture that burns more quickly and efficiently.

**[0010]** Two stroke engines have lesser volumetric efficiency due to obstructions in ports and short time/area available during intake and transfer phases. Due to the size, shape, and angles of the ports, the charge is in a higher state of turbulence when entering the two stroke cylinder than the four stroke cylinder. Four stroke engines require more ignition advance to operate efficiently due to the lower state of turbulence and a denser charge before combustion. The turbulence inside the cylinder and head mainly helps to maintain the air-fuel mixture in a gaseous state and prevent condensation of fuel droplets.

**[0011]** The squish area is normally placed in the outer circumference of the combustion chamber and are machined smooth. The squish area could be a flat or a tapered area or two separate squish areas on opposite sides. The squish areas are either flat or angled depending on the profile of the piston crown.

**[0012]** In principle, the piston on the upward stroke causes the compression to progressively increase. Nearing TDC, the gases around the squish area and the piston crown are pushed toward the combustion chamber cavity causing turbulence and improving flame propagation as ignition has occurred before TDC thereby greatly reducing pinging and detonation. Present day two stroke combustion chambers are hemispherical or "top hat" type with a circular or partial squish area. The spark plugs are located centrally or offset depending on the requirement.

**[0013]** Present day four stroke combustion chambers house the inlet and exhaust valves. Multiple valve layouts are standard in high performance designs. Partial or circular squish areas can be provided. The spark plug location depends on design and availability of space.

**[0014]** Cylinder heads are largely made of alloys of aluminum having steel inserts for valve seats. Basic designs typically are bath tub, wedged or double wedged with a flat roof or hemispherical cross flow type with inclined valve layouts.

**[0015]** Standard practice has been to have squish areas of 20% to 40% or more of the combustion chamber area which is either concentric or offset to the cylinder axis at close proximities to the piston crown, causing turbulence in two stroke engines. Depending on the number of valves and layouts, four stroke combustion chambers can be machined to provide the squish area resulting in a puff of mixture pushed towards the spark plug causing turbulence and resulting in better combustion.

**[0016]** Various methods for improving efficiencies of combustion in two and four stroke methods have been attempted. U.S. Pat. No. 5,065,715 which is incorporated herein by reference, discloses the use of a central bowl along with a plurality of discrete channels circumferentially spaced about the bowl where each of the channels opens into the bowl. One problem with this design is the extensive modifications to the piston. Additionally, it is believed that the bowl actually decreases efficiency.

**[0017]** The present invention does not contemplate heterogeneous charge compression ignition engine designs utilizing divided combustion chambers. The divided chamber engine (sometimes called a pre-combustion chamber or swirl chamber engine) has the compression volume divided in distinct chambers separated by a dividing passageway. The area between the piston and cylinder is called the main combustion

chamber and the remainder of the combustion chamber area located in the cylinder head is called the antechamber, pre-chamber or swirl chamber. With this design, unlike a homogeneous charge engine, no fuel is pulled into the cylinder during the intake cycle, only air; fuel is directly injected into the antechamber late in the compression stroke. The function of the antechamber is to break up the liquid fuel mixing it with air from the cylinder late in the compression stroke.

[0018] There is a need for improving the efficiencies in two and four stroke homogeneous charge spark ignition internal combustion engines using modified pistons having at least one groove in the crowns.

[0019] While certain novel features of this invention shown and described below are pointed out in the annexed claims, the invention is not intended to be limited to the details specified, since a person of ordinary skill in the relevant art would understand that various omissions, modifications, substitutions and changes in the forms and details of the device illustrated and in its operation may be made without departing in anyway from the spirit of the present invention. No feature of the invention is critical or essential unless it is expressly stated as being "critical" or "essential."

#### BRIEF SUMMARY

[0020] The apparatus of the present invention solves the problems confronted in the art in a simple and straightforward manner. What is provided is a method and apparatus for improving the efficiency of an engine.

[0021] Combustion efficiency of an engine is related to the level of turbulence in the combustion chamber during combustion. Current squish designs are inadequate in converting kinetic energy into turbulence. With current designs, as the squish flow enters the combustion chamber cavity, it meets the forces of combustion causing transition to turbulence very quickly. The effect is a low turbulence transition rate and building of combustion end gas pressure and temperature in the squish area.

[0022] It is believed that traditional squish flow travels a short distance into the combustion chamber cavity. Once the squish flow enters the open area of the combustion chamber cavity, it is met with violent forces of combustion causing the flow to lose velocity and instantly become turbulent limiting travel distance. Traditional squish flow designs are believed to mask combustion and create crevice areas of high pressures and temperatures.

[0023] In one embodiment is provided an improved piston design, which increases an engine's ability to convert the kinetic energy created with piston movement into turbulent energy, and providing a means of directing the turbulence into specific areas of the engine's combustion chamber where it can provide the most benefit, and balancing cylinder pressures and temperatures during combustion. With the improved piston design of this embodiment, as the piston approaches top dead center, a portion of the squish air-fuel mixture is directed by grooves in the piston crown in the form of fluid flow. This fluid flow is channeled across the piston crown in the form of high velocity laminar flow. As the fluid exits the grooves in the lower pressure area of the combustion chamber cavity, flow transition is made from laminar to turbulent. The effect is delayed transition to turbulent and greater turbulence transition rate along with more of the kinetic energy being converted into turbulence at the base of the combustion chamber cavity where it can provide the most benefit.

[0024] Combustion of air-fuel mixture generates very high pressures and temperatures. In one embodiment high velocity fluid flow in the crown of an improved piston design effectively balances cylinder pressures and temperature. As pressure builds ahead of the advancing flame front, the pressure build up bleeds into the grooves in the piston crown eliminating high pressure areas and hot spots in the chamber. In addition, channeling the squish flow across the piston crown increases squish flow velocity, resulting in improved heat transfer between the combustion end gas and piston crown, further reducing detonation tendencies.

[0025] One advantage of altering fluid flow with a grooved piston design is the piston compression face has a very large surface area, near 100% of the size of the bore with very few obstructions. This large surface area allows many variations of groove layouts, numbers and lengths. This provides a method of regulating the conversion of turbulence to the needs of the specific engine.

[0026] In one embodiment grooved piston designs relieve pressure and temperature build ups and balance combustion pressures and temperatures across the piston's compression surface.

[0027] In one embodiment, a means of facilitating smooth laminar flow across the piston's compression surface with little or no disruption of fluid flow under the forces of combustion is provided.

[0028] In one embodiment, an altered squish flow path increasing velocity is provided across the piston's compression surface, facilitating greater distances traveled by the flow.

[0029] In one embodiment a modified piston design is provided having a compression face with a least one groove.

[0030] Various embodiments with different groove configurations are provided.

[0031] In one embodiment a method and apparatus is provided for increasing turbulence transition rate, converting more of the kinetic energy that is created with piston movement into turbulence.

[0032] In one embodiment, a method and apparatus for delaying transition of kinetic energy to turbulent energy is provided.

[0033] In one embodiment is provided a method and apparatus for directing the turbulence into specific areas of the combustion chamber where it can provide the most benefit.

[0034] In one embodiment is provided a method and apparatus for balancing cylinder pressures and temperatures during combustion, eliminating high pressure areas and hot spots in the chamber.

[0035] In one embodiment is provided a method and apparatus for increasing squish flow velocity.

[0036] In one embodiment is provided a method and apparatus for improving heat transfer between the combustion end gas and the piston crown.

[0037] In one embodiment is provided a method and apparatus for reducing detonation tendencies.

[0038] In one embodiment is provided a method and apparatus for regulating the conversion of turbulence to the needs of the specific engine.

[0039] The drawings constitute a part of this specification and include exemplary embodiments to the invention, which may be embodied in various forms.

#### BRIEF DESCRIPTION OF THE SEVERAL VIEWS OF THE DRAWINGS

[0040] For a further understanding of the nature, objects, and advantages of the present invention, reference should be

made to the following detailed description, read in conjunction with the following drawings, wherein like reference numerals denote like elements and wherein:

**[0041]** FIG. 1 is a perspective view of a prior art piston with flat compression face;

**[0042]** FIG. 2 is a schematic design illustrating movement of an air-fuel mixture from the squish area with a prior art piston;

**[0043]** FIG. 3 shows a piston with a three groove lay out;

**[0044]** FIG. 4 is a cutaway perspective view showing the piston of FIG. 3 in an engine;

**[0045]** FIG. 5 illustrates movement of a mixture from the squish area into the combustion chamber cavity using the piston of FIG. 3;

**[0046]** FIG. 6 is a top view of the compression face of an alternative piston indicating movement of an air-fuel mixture from the squish area;

**[0047]** FIG. 7 is a perspective view of another alternative piston having a single groove;

**[0048]** FIG. 8 shows a groove with branches;

**[0049]** FIG. 9 shows a groove with alternative branches;

**[0050]** FIG. 10 shows a groove with alternative branches;

**[0051]** FIG. 11 shows multiple grooves on the compression face of a piston;

**[0052]** FIG. 12 shows a piston with multiple grooves places offset and immediately adjacent each other;

**[0053]** FIG. 13 shows a piston with valve relief areas and multiple grooves that widen and become more shallow as they extend toward the piston's outer perimeter;

**[0054]** FIG. 14 is a perspective view of a piston having valve relief areas and a groove;

**[0055]** FIG. 15 is a perspective view of a piston having two valve relief areas and multiple grooves;

**[0056]** FIG. 16 is a perspective view of a piston having multiple grooves which are offset from each other along with a cylinder head superimposed;

**[0057]** FIG. 17 is a perspective view of a piston showing a groove layout in a flat piston surface area opposite of the spark plug where the piston includes a dish or recessed area under the combustion chamber cavity;

**[0058]** FIG. 18 is a perspective view of a piston having raised areas and multiple grooves;

#### DETAILED DESCRIPTION

**[0059]** Detailed descriptions of one or more preferred embodiments are provided herein. It is to be understood, however, that the present invention may be embodied in various forms. Therefore, specific details disclosed herein are not to be interpreted as limiting, but rather as a basis for the claims and as a representative basis for teaching one skilled in the art to employ the present invention in any appropriate system, structure or manner.

**[0060]** These detailed descriptions of the pistons provided herein are elements of a homogeneous charge spark ignition internal combustion engine. The homogenous air-fuel mixture is achieved by injection of fuel into the inlet air stream or by carburetion. The engine is fitted with pistons moving up and down in cylinders for the purpose of turning a crankshaft. A bottom opened combustion chamber cavity is formed in a cylinder head that is fixed to the top of the each cylinder. As the piston approaches top dead center, the compression face of the piston combines with the compression face of the cylinder head defining a single combustion space for each cylinder; the compression face of the piston forms the base of

the combustion chamber. Flat portions of the cylinder heads compression face at the parameter of the combustion chamber cavity come in close proximity with flat surface portions of the compression face of the piston to define squish area(s). These squish areas are designed to displace the air-fuel mixture between the flat surfaces as the piston reaches top dead center. The present invention provides a means of channeling this air-fuel mixture from the squish area across the compression face of the piston top to a pre-determined location at the base of the bottom opened combustion chamber cavity to promote mixing of the air and fuel into a more homogeneous mixture that burns more quickly and efficiently.

**[0061]** FIG. 1 is a perspective view of a prior art piston 5 with flat compression face 6. FIG. 2 is a schematic diagram illustrating displacement of an air-fuel mixture 8 from the squish area 7 with prior art piston 5. Compression face 6 located on the crown of piston 5 forms the base of the bottom opened combustion chamber cavity 1025 to define a single combustion space 1015. Piston 5 includes no grooves to direct flow of an air-fuel mixture 8 in the direction of arrows 9 as piston 5 moves in the direction of arrow 4 with an inefficient development/creation/directing of turbulence in the air-fuel mixture for combustion. .

**[0062]** FIG. 3 shows a piston 10 with a three groove lay out. Piston 10 has compression face 20 and grooves 30, 40, 50. Grooves 30, 40, 50 can have planar edges, squared, or be rounded. Grooves 30, 40, 50 can be molded or can be machined. Grooves 30, 40, 50 increase the development/creation/directing of turbulence in the air-fuel mixture for combustion. Groove 30 has first end 32 and second end 34 and passes through geometric center 12 of piston 10. Groove 40 has first end 42 and second end 44. groove 50 has first end 52 and second end 54. Grooves 30, 40, and/or 50 can better direct flow of an air-fuel mixture across the compression face 20 of piston 10. Groove 30 is shown passing through geometric center 12 of piston 10, however, this need not be the case. Grooves 40 and 50 are shown generally symmetrically located above groove 30, however this need not be the case. Grooves 30, 40, 50 are shown as being parallel, however, in alternative embodiments these grooves can be non-parallel. Also alternatively, one or more of these grooves can intersect one or more of the other grooves.

**[0063]** FIGS. 4 and 5 schematically illustrate movement of an air-fuel mixture 1050 through the squish area 1030 of an engine 1000. Engine 1000 can comprise one or more cylinders 1070 and pistons 10. One or more heads 1010 can also be included. For simplicity only one cylinder 1070 and one piston 10 is shown. In this diagram piston 10 is shown at top dead center (after having moved in the direction of arrow 14). Squish area 1030 is generally the space between the compression face 20 of piston 10 and lower portion 1020 of head 1010. Compression face 20 can be the piston crown of piston 10, as piston 10 moves in the direction of arrow 14 an air-fuel mixture 1032 is compressed in squish area 1030, causing air-fuel mixture 1050 to move in the direction of arrows 1032. Special grooves, 30, 40, 50 on compression face 20 of piston 1010 can facilitate directing air-fuel mixture 1050.

**[0064]** FIG. 6 is a top view of piston 10' showing an alternative embodiment of a grooved piston. Piston 10' can have a single groove 800 on compression face 20. Groove 800 can have distal 802 and proximate 804 ends. Groove 800 can widen from distal 802 to proximate end 804. Compression face 20 can also include valve relief areas 24, 25, 26, 27. Groove 800 can have planar edges, squared, or be rounded.

Groove **800** can be molded or can be machined. Schematically illustrated in FIG. **6** is the movement of air-fuel mixture **1050** from squish area in the direction of arrow **1033**.

[0065] FIG. **7** is a perspective view of a piston **10"** showing an alternative embodiment of a grooved piston. Piston **10"** can include compression face **20**. On compression face **20** can be groove **30**, which can have a uniform width and extend through geometric center **12** of compression face **20**. First end **32** can be located adjacent the perimeter of compression face **20**. Second end **34** can be located adjacent the perimeter of compression face **20**, but opposite first end **32**. Alternatively, groove **30** can end at geometric center **12**, groove **30** can be of uniform depth. Alternatively, it can have a non-uniform depth—such as increasing in depth towards geometric center **12** from first end **40** to geometric center **12** along with increasing in depth from second end **34** to geometric center **12**. Alternatively, it can decrease in depth toward geometric center **12**, groove **30** can be of uniform width. Alternatively, it can have a non-uniform width Such as decreasing width toward geometric center **12** from first end **40** to geometric center **12** along with decreasing width from second end **34** to geometric center **12**. Alternatively, it can increase in width toward geometric center **12**.

[0066] In alternative embodiments, grooves can have irregular shapes, such as branching, curves, or other shapes differing from straight lines.

[0067] FIG. **8** shows an alternative groove **100** with branches **110, 120**. Groove **100** can include first end **102** and second end **104**. Branches **110, 120** can be curved and of generally uniform width. Branches **110, 120** can curve toward second end **104**. Branches **110, 120** can be located generally opposite of one another in relation to groove **100**. Alternatively, branches **110, 120** can widen from first ends **112, 122** to second ends **114, 124**. Additional pairs of branches can be added along the length of groove **100**.

[0068] FIG. **9** shows an alternative groove **200** with branches **210, 220**. Groove **200** can include first end **202** and second end **204**. Branches **210, 220** can be curved and can widen from first end **212, 222** to second ends **214, 224**. The sides of branches **210, 220** closest to second end **204** can curve toward second end **204**. The sides of branches **210, 220** closest to first end **202** can curve toward first end **202**. Branches **210, 220** can be located generally opposite of one another in relation to groove **200**. Additional pairs of branches can be added along the length of groove **200**.

[0069] FIG. **10** shows an alternative groove **300** with branches **310, 320**. Groove **300** can include first end **302** and second end **304**. Branches **310, 320** can be curved and can widen from first ends **312, 322** to second ends **314, 324**. Branches **310, 320** can curve toward second end **304**. Branches **310, 320** can be located generally opposite of one another in relation to groove **300**. Additional pairs of branches can be added along the length of groove **300**.

[0070] In one embodiment the grooves and/or branches of FIG. **8-10** can be combined and/or mixed with each other.

[0071] FIG. **11** shows piston **10"** having multiple grooves **500, 540, 580, 620, 660, 700, 740** on its compression face **20**. Groove **500** can pass through geometric center **510** of piston **10"** and have first end **502** and second end **504**. Groove **540** can have first end **542** and second end **544**. Groove **580** can have first end **582** and second end **584**. Groove **620** can have first end **622** and second end **624**. Groove **660** can have first end **662** and second end **664**. Groove **700** can have first end **702** and second end **704**. Groove **740** can have first end **742** and

second end **744**. In this embodiment the grooves are parallel, but offset with respect to each other, at least with respect to the next adjacent groove. Each groove can include first and second ends.

[0072] FIG. **12** shows a piston **1700** with multiple grooves **1702, 1704, 1706**, etc., placed offset and immediately adjacent each other. In this embodiment the grooves are parallel, but offset with respect to each other, at least with respect to the next adjacent groove. Each groove can include first and second ends.

[0073] FIG. **13** shows a piston **1800** with a single center groove **1830** and grooves **1860, 1862** and **1870, 1872** entering the valve relief areas **1824, 1825, 1826, 1827**. Center groove **1830** can pass through geometric center **1860** of piston **1800**. Any of the grooves can be of uniform depth. Alternatively, the depth can vary from distal to center, and from center to opposite distal ends.

[0074] FIG. **14** is a perspective view of a piston **1100** having valve relief areas **410, 420** and groove **400**. Groove **400**, which can have a uniform width and extend through geometric center **60** of compression face **20**. First end **402** can be located adjacent the perimeter of compression face **20**. Second end **404** can be located adjacent the perimeter of compression face **20**. Groove **400** can be of uniform depth. Alternatively, it can have a non-uniform depth—such as an increasing depth toward geometric center **60** from first end **404** to geometric center **60** along with an increasing depth from second end **404** to geometric center **60**. Alternatively, it can decrease in depth toward geometric center **60**.

[0075] FIG. **15** shows a piston **1600** with two valve relief areas **1630, 1632** and multiple grooves **1640, 1650, 1660, 1670**. The lower grooves **1640, 1650** are fed from the squish area on the spark plug side of the head and the upper grooves **1660, 1670** are fed from the opposite squish area. This design also utilizes a groove layout that does not pass through the geometric center **1610** of the compression face. Grooves **1640, 1650** can be parallel and line up with grooves **1660, 1670**.

[0076] FIG. **16** shows a piston **1400** having multiple grooves **1440, 1450, 1460** which are offset from each other along with a superimposed cylinder head **1430**. When the grooves are offset with respect to each other and a cylinder head **1430** with two squish areas on opposite sides is overlaid using this embodiment, the squish flow in adjacent groove flow in the opposite directions.

[0077] FIG. **17** shows a piston **1500** having groove lay out **1540, 1550, 1560** in a flat piston surface area opposite of the spark plug where piston **1500** includes a dish or recessed area **1510** under the combustion chamber scoop.

[0078] FIG. **18** is a perspective view of a piston **1200** having raised areas **1210, 1220** and groove **1250**. Valve relief area **1230** can also be provided adjacent raised areas **1210, 1220**. Groove **1250** can have a uniform width and extend through geometric center **60** of compression face **1220**. First end **1252** can be located adjacent the perimeter of compression face **1220**. Second end **1254** can be located on the opposite side of raised areas **1210, 1220**. Groove **1250** can be of uniform depth. Alternatively, it can have a non-uniform depth—such as an increasing depth toward geometric center **60** from first end **1252** to second end **1254**. Alternatively, the depth can be set so that it remains constant even when passing through raised areas **1210, 1220**. Secondary grooves **1260, 1270** can also be used. These can be spaced apart in related to groove **1250** and can be parallel to groove **1250**.

**[0079]** It is believed that placement of grooves in pistons is an improvement compared to grooves in cylinder heads. When the grooves are placed in the cylinder head, the length and location of the grooves are restricted by the combustion chamber scoop area and the valves, the scoop areas consumes 65%-85% of the cylinder head deck surface. This design is limited to directing the "puff" of the air-fuel mixture **1050** to the parameter of the combustion chamber cavity. When the grooves are placed in the piston face the "puff" of the air-fuel mixture **1050** can be directed across the entire face of the piston. One limitation where one or more grooves are placed on the piston face is when the engine design requires valve relief notches in the piston top.

**[0080]** In one embodiment improved piston design permits 10% or more increase in compression ratio compared to present engine designs with out detonation tendencies when burning intended fuel.

**[0081]** The maximum cylinder pressure that can be developed without producing detonation determines efficiency and power production limits in an spark ignition internal combustion engine. Nearly all internal combustion piston engines are limited in their efficiency and power output by the octane and detonation sensitivity of the fuel they use.

**[0082]** Current practice of OEM manufacturers is to produce engines with 9:1-11:1 compression ratios depending on combustion chamber design, the grade of fuel to be used and intended application. During design, the specific engine compression ratio is adjusted to maximum efficiency/power on the intended fuel. Engines burning **87** octane regular fuel are detonation limited to 10:1 compression. With superior **91** octane premium fuel, ratios up to 11:1 can be used to deliver additional efficiency and power.

**[0083]** Utilizing the improved piston design engines are able to run compression ratios that are 10% or more higher than current practice. Burning 91 octane premium fuel, engines are able to operate with compression ratios of 11.5:1 or higher. The design of the improved piston provides balanced cylinder pressures and temperatures during combustion; as a result high pressure areas and hot spots in the chamber are eliminated. This combined with increased squish flow velocity that improves heat transfer between the combustion end gas and the piston crown reduces detonation tendencies allowing the higher compression with the available fuels.

**[0084]** In one embodiment a method of increasing the squish flow outlet area by 100% or more is provided. Current squish designs are limited to delivering squish action at the perimeter of the combustion chamber cavity. The effect is a low turbulence transition rate and building of combustion end gas pressure and temperature in the squish area. The resulting low kinetic energy transition to turbulence has proven to be inadequate for low RPM performance and economy.

**[0085]** Channeling the squish flow across the piston top with the improved piston design increases the squish flow outlet area by 100% or more. As the piston approaches top dead center, a portion of the squish air-fuel mixture is directed into grooves in the piston crown in the form of fluid flow. This fluid flow is channeled across the piston crown in the form of high velocity laminar flow. As the fluid exits the grooves in the lower pressure area of the combustion chamber cavity, flow transition is made from laminar to turbulent. The effect is delayed transition to turbulent and greater turbulence transi-

tion rate; more of the kinetic energy is converted into turbulence at the base of the combustion chamber cavity where it can provide the most benefit.

**[0086]** In one embodiment is provided a piston design that permits 10% or more increase in squish area with out increasing detonation tendencies burning intended fuel.

**[0087]** Modern practice is to design engines with squish area to bore ratios of 12% to 40%. Engines utilizing larger squish areas have a tendency of developing isolated regions of high pressure and temperatures in the unburned air-fuel mixture during the combustion process that can lead to end gas detonation.

**[0088]** The improved piston design provides a method of balancing cylinder pressures and temperatures during combustion, eliminating high pressure areas and hot spots in the chamber. As a result squish areas 10% larger or more compared to current practice is possible. As pressure builds ahead of the advancing flame front, the pressure build up bleeds into the grooves in the piston crown eliminating high pressure area and hot spots in the chamber.

**[0089]** The following is a list of reference numerals:

---

LIST FOR REFERENCE NUMERALS

---

(Reference No.)	(Description)
4	arrow
5	prior art piston
6	compression face
7	squish area
8	mixture of air-fuel
9	arrows
10	piston
12	geometric center
14	arrow
20	compression face
22	squish area
24	valve relief area
25	valve relief area
26	valve relief area
27	valve relief area
30	straight groove
32	first end
34	second end
40	straight groove
42	first end
44	second end
50	straight groove
50	first end
54	second end
60	geometric center
100	groove with branches of uniform width
102	first end
104	second end
110	first branch
112	first end of first branch
114	second end of first branch
120	second branch
122	first end of second branch
124	second end of second branch
200	groove with branches of non-uniform width
202	first end
204	second end
210	first branch
212	first end of first branch
214	second end of first branch
220	second branch
222	first end of second branch
224	second end of second branch
300	groove with branches of non-uniform width
302	first end

-continued

<u>LIST FOR REFERENCE NUMERALS</u>	
(Reference No.)	(Description)
304	second end
310	first branch
312	first end of first branch
314	second end of first branch
320	second branch
322	first end of second branch
324	second end of second branch
400	groove
402	first end
404	second end
410	valve relief area
420	valve relief area
500	groove
502	first end
504	second end
510	geometric center
540	groove
542	first end
544	second end
580	groove
582	first end
584	second end
620	groove
622	first end
624	second end
660	groove
662	first end
664	second end
700	groove
702	first end
704	second end
740	groove
742	first end
744	second end
800	widening groove
802	first end
804	second end
1000	engine
1010	head
1012	squish area
1015	single combustion space
1020	lower portion of head
1025	base of bottom opened combustion chamber cavity
1030	squish area
1032	arrows
1033	arrow
1050	mixture and air-fuel
1060	spark plug
1070	cylinder
1200	piston
1210	raised area
1220	raised area
1230	valve relief area
1250	groove
1252	first end
1254	second end
1260	secondary groove
1270	secondary groove
1400	piston
1430	superimposed cylinder head
1440	groove
1450	groove
1460	groove
1500	piston
1510	dished or recessed area
1530	valve relief area
1540	groove
1550	groove
1560	groove
1600	piston
1610	geometric center
1630	valve relief area

-continued

<u>LIST FOR REFERENCE NUMERALS</u>	
(Reference No.)	(Description)
1632	valve relief area
1640	groove
1650	groove
1660	groove
1670	groove
1700	piston
1702	groove
1704	groove
1706	groove
1708	groove
1710	groove
1800	piston
1812	geometric center
1820	compression face
1822	squish area
1824	valve relief area
1825	valve relief area
1826	valve relief area
1827	valve relief area
1830	straight groove
1840	first end
1850	second end
1860	groove
1862	groove
1870	groove
1872	groove

**[0090]** All measurement disclosed herein are at standard temperature and pressure, at sea level on Earth, unless indicated otherwise. All materials used or intended to be used in a human being are biocompatible, unless indicated otherwise.

**[0091]** It will be understood that each of the elements described above, or two or more together may also find a useful application in other types of methods differing from the type described above. Without further analysis, the foregoing will so fully reveal the gist of the present invention that others can, by applying current knowledge, readily adapt it for various applications without omitting features that, from the standpoint of prior art, fairly constitute essential characteristics of the generic or specific aspects of this invention set forth in the appended claims. The foregoing embodiments are presented by way of example only; the scope of the present invention is to be limited only by the following claims.

1. A homogeneous charge spark ignition internal combustion engine comprising:

- (a) at least one piston reciprocal in at least one cylinder, the cylinder having a cylinder head, the cylinder head having a bottom open combustion chamber cavity, as the piston approaches top dead center, the top surface of the piston combines with the lower portion of the cylinder head to define a single combustion space which confines the entire compressed air-fuel volume, flat portions of the cylinder head at the parameter of the combustion chamber cavity come in close proximity with flat surface portions of the piston to define squish area(s);
- (b) the piston having a compression face of circular shape; and
- (c) at least one groove formed in the compression face and having first and second longitudinal ends, the at least one groove being of uniform width and the first and second longitudinal ends being located on opposed sides of the circular compression face, said at least one groove channeling air-fuel mixture from the squish area across the



- compression face of a piston top to a pre-determined location at the base of the combustion chamber cavity.
- 2. The engine of claim 1, wherein the at least one groove passes through the geometric center of the compression face.
- 3. The engine of claim 1, wherein the at least one groove includes at least one pair of opposed branches.
- 4. The engine of claim 3, wherein the pair of opposed branches are curved and generally uniform width.
- 5. The engine of claim 3, wherein each branch decreases in area as it extends away from the at least one groove.
- 6. The engine of claim 3, wherein a second pair of branches are connected to the at least one groove.
- 7. The engine of claim 4, wherein the each branch curves toward the geometric center of the compression face.
- 8. A homogeneous charge spark ignition internal combustion engine comprising:
  - (a) at least one piston reciprocal in at least one cylinder, the cylinder having a cylinder head, the cylinder head having a bottom open combustion chamber cavity, as the piston approaches top dead center, the top surface of the piston combines with the lower portion of the cylinder head to define a single combustion space which confines the entire compressed air-fuel volume, flat portions of the cylinder head at the parameter of the combustion chamber cavity come in close proximity with flat surface portions of the piston to define squish area(s);
  - (b) the piston having a compression face of circular shape;
  - (c) at least one groove formed in the compression face and having first and second longitudinal ends, said at least one groove channeling air-fuel mixture from the squish area across the compression face of a piston top to a pre-determined location at the base of the combustion chamber cavity; and
  - (d) the first end being located adjacent to the parameter of the circular shape, and wherein the second end opens adjacent the geometric center of the compression face.
- 9. The engine of claim 8, wherein the at least one groove includes at least one pair of opposed branches.
- 10. The engine of claim 9, wherein the pair of opposed branches are curved and generally uniform width.
- 11. The engine of claim 9, wherein the branches branch off from the at least one groove.

- 12. The engine of claim 9, wherein a second pair of branches are connected to the at least one groove.
- 13. The engine of claim 10, wherein the each branch curves toward the geometric center of the compression face.
- 14. The engine of claim 10, wherein each branch decreases in area as it extends away from the at least one groove.
- 15. The engine of claim 12, wherein each branch has proximal and distal sides, and the proximal sides curve in a direction generally opposite that of the distal sides.
- 16. The engine of claim 12, wherein each branch has proximal and distal sides, and the proximal sides curve in a direction generally similar to that of the distal sides.
- 17. A homogeneous charge spark ignition internal combustion engine comprising:
  - (a) at least one piston reciprocal in at least one cylinder, the cylinder having a cylinder head, the cylinder head having a bottom open combustion chamber cavity, as the piston approaches top dead center, the top surface of the piston combines with the lower portion of the cylinder head to define a single combustion space which confines the entire compressed air-fuel volume, flat portions of the cylinder head at the parameter of the combustion chamber cavity come in close proximity with flat surface portions of the piston to define squish area(s);
  - (b) the piston having a compression face of circular shape; and
  - (c) a plurality of grooves formed in the compression face and having first and second longitudinal ends arranged in a parallel configuration, said grooves channeling air-fuel mixture from the squish area across the compression face of a piston top to a pre-determined location at the base of the combustion chamber cavity.
- 18. The engine of claim 17, wherein the first and second ends of each groove are offset at least with respect to the next groove.
- 19. The engine of claim 17, wherein said grooves are formed in a spaced-apart relationship to each other, and wherein said first and second ends of adjacent grooves are arranged in a staggered pattern.
- 20. The engine of claim 17, wherein said grooves are formed in immediate proximity to each other.

\* \* \* \* \*