



US 20050262392A1

(19) **United States**

(12) **Patent Application Publication**

Irving

(10) **Pub. No.: US 2005/0262392 A1**

(43) **Pub. Date: Nov. 24, 2005**

(54) **EMBEDDED SERVER CHASSIS HARDWARE MASTER SYSTEM AND METHOD**

Publication Classification

(75) Inventor: **Guy B. Irving**, The Woodlands, TX (US)

(51) **Int. Cl.**7 **G06F 11/00**

(52) **U.S. Cl.** **714/11**

Correspondence Address:
BAKER BOTTS L.L.P.
2001 ROSS AVENUE
SUITE 600
DALLAS, TX 75201-2980 (US)

(57) **ABSTRACT**

(73) Assignee: **RLX Technologies, Inc., a Delaware corporation**

A system and method for monitoring a plurality of server processing cards of a server chassis includes selecting at least one hardware master from among a plurality of server processing cards. A hardware master control signal may be transmitted to the hardware master. A master control module coupled with the hardware master may be activated in response to the master control signal. In accordance with a particular embodiment of the present invention, the hardware master may be operable to at least partially monitor operating information regarding at least a subset of the plurality of server processing cards. The operating information may include health and/or configuration data associated with the subset of the plurality of server processing cards.

(21) Appl. No.: **11/086,265**

(22) Filed: **Mar. 21, 2005**

Related U.S. Application Data

(63) Continuation of application No. 09/848,807, filed on May 4, 2001, now Pat. No. 6,871,300.

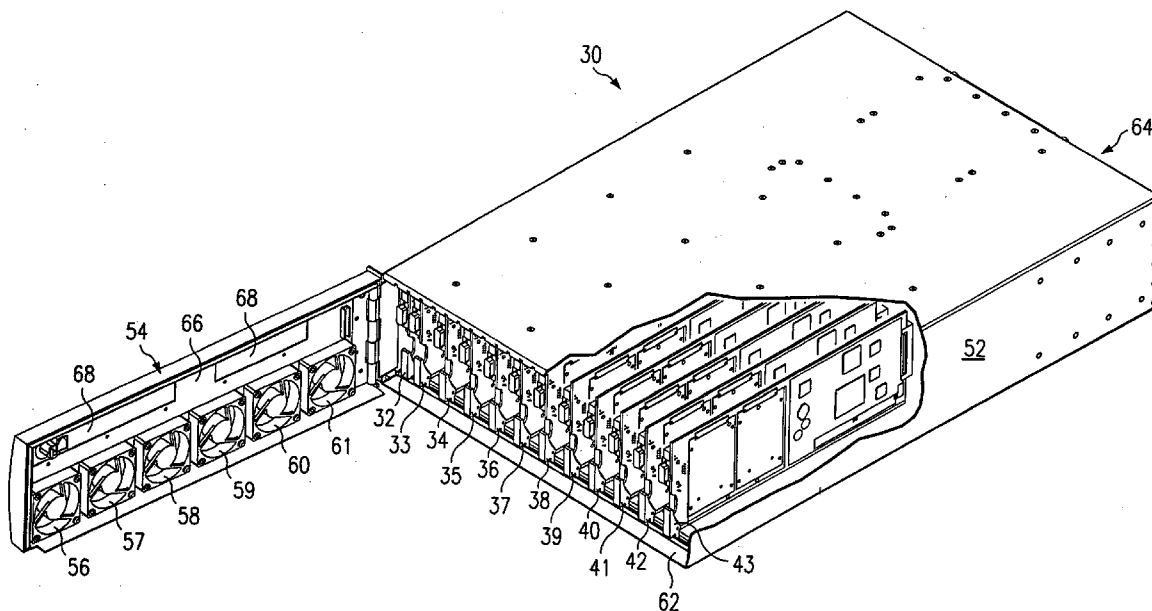

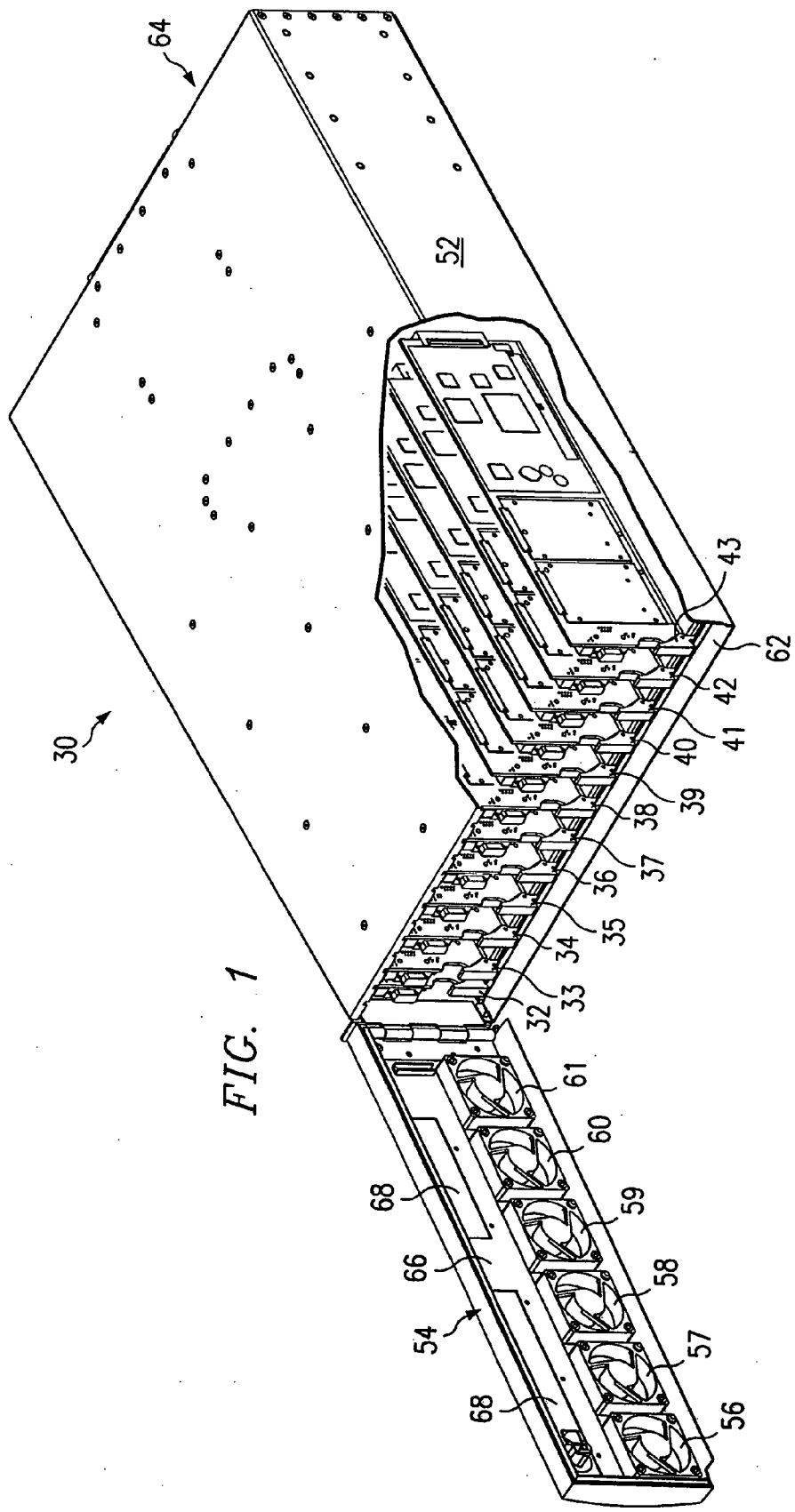

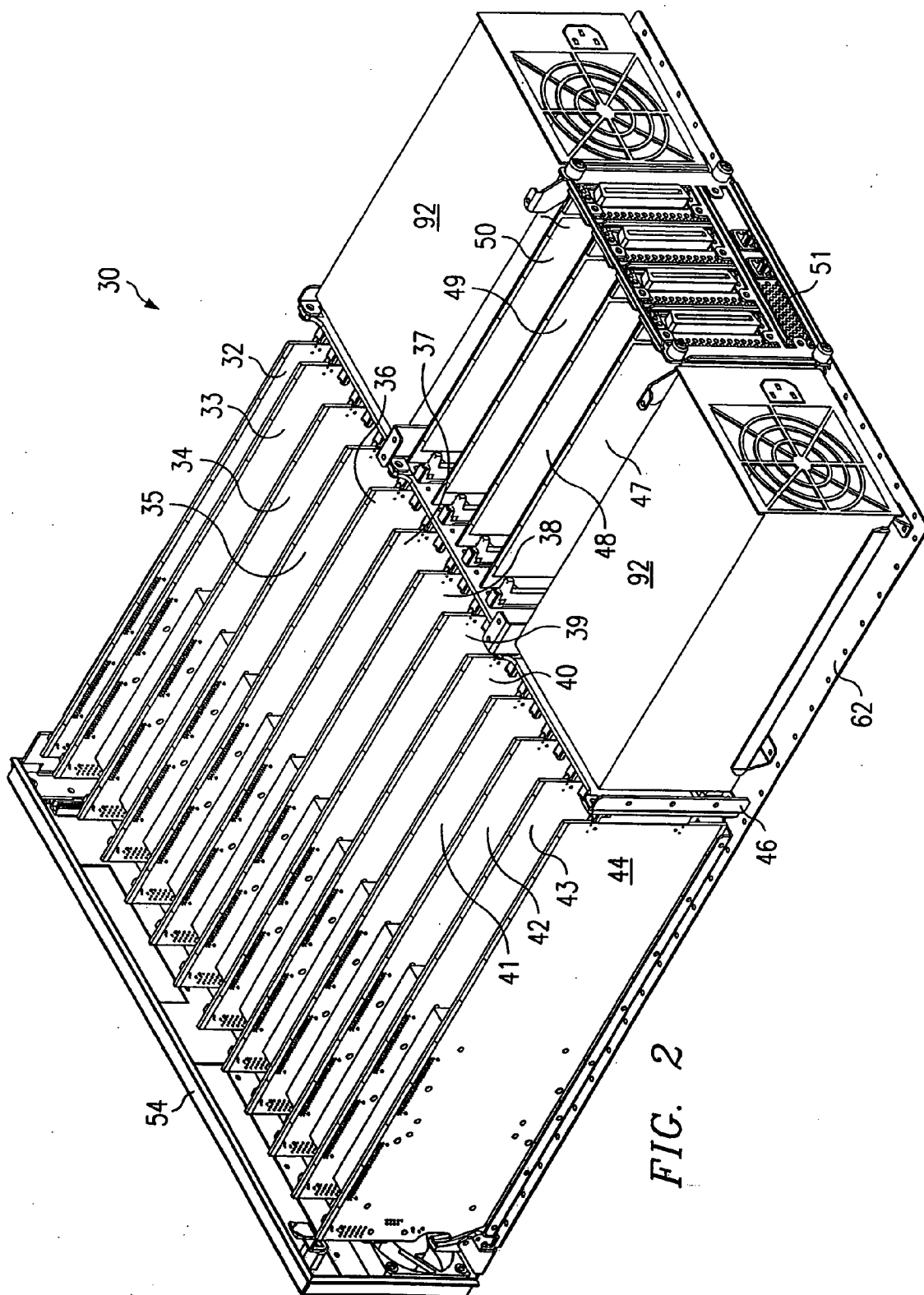

FIG. 2

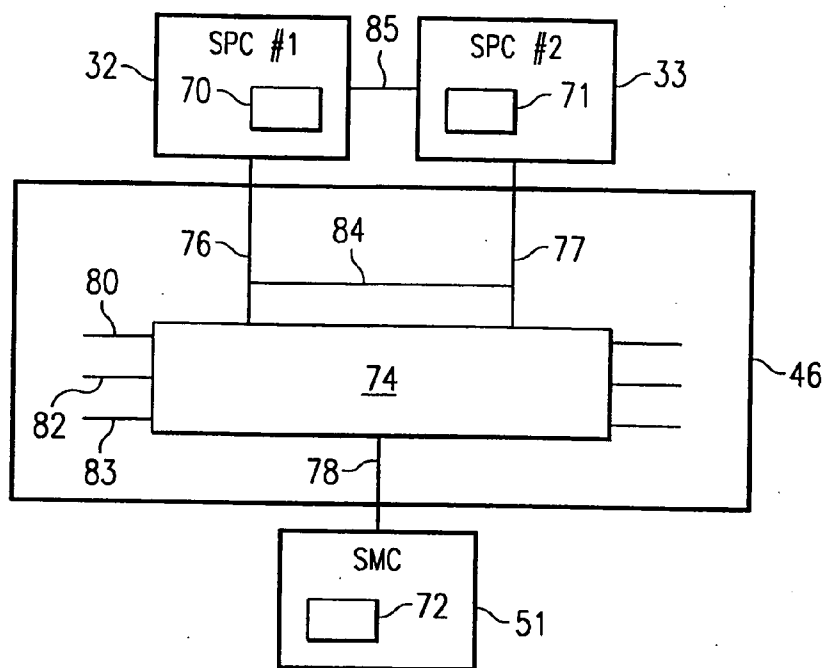

FIG. 3

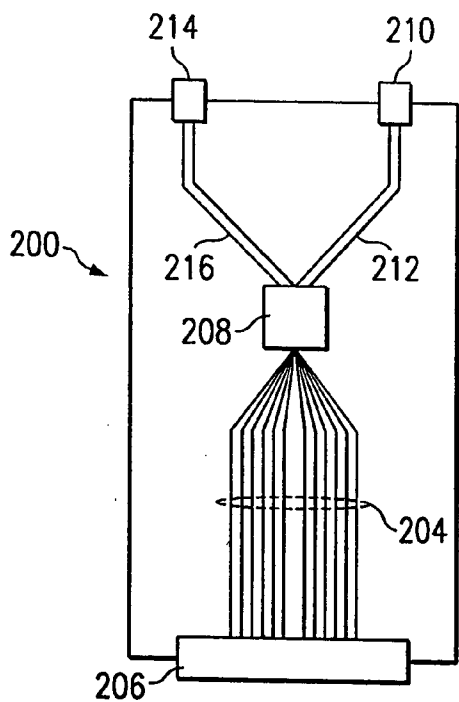

FIG. 6A

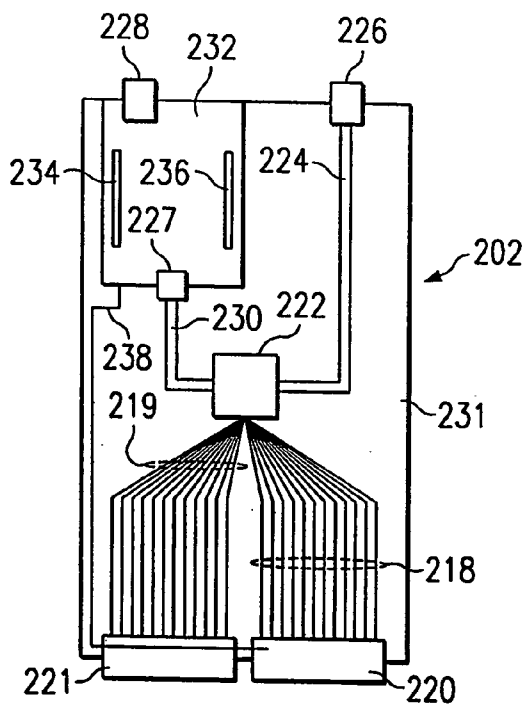

FIG. 6B

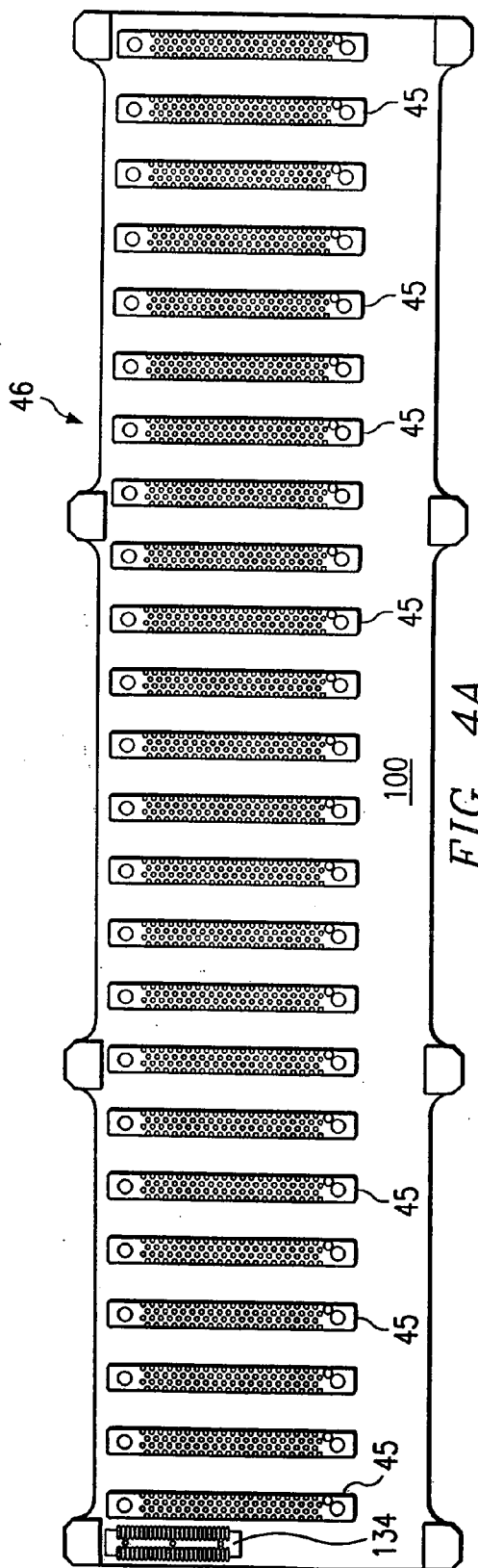

FIG. 4A

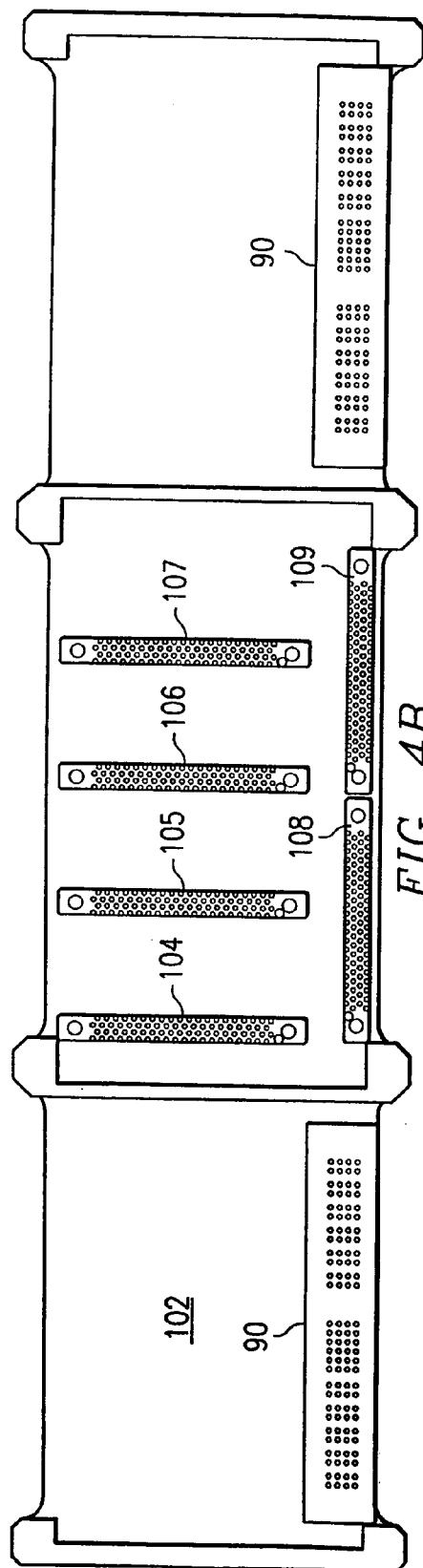

FIG. 4B

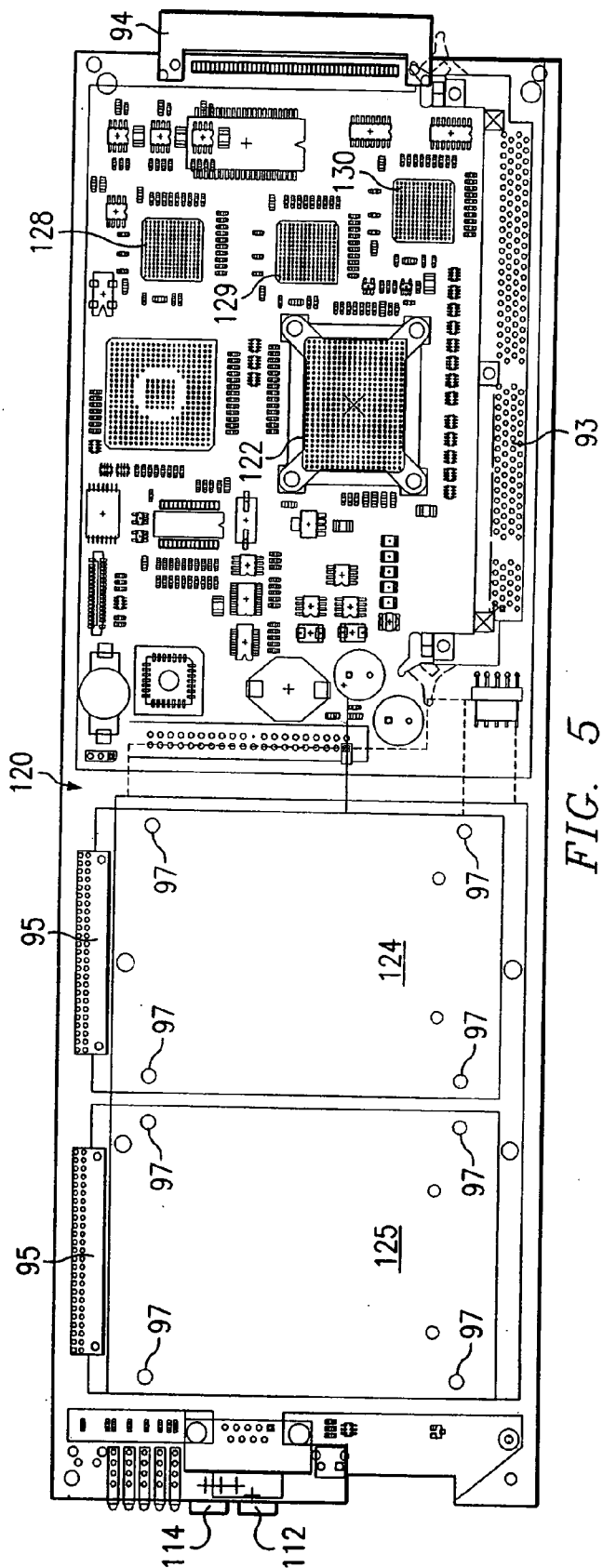

FIG. 5

FIG. 7

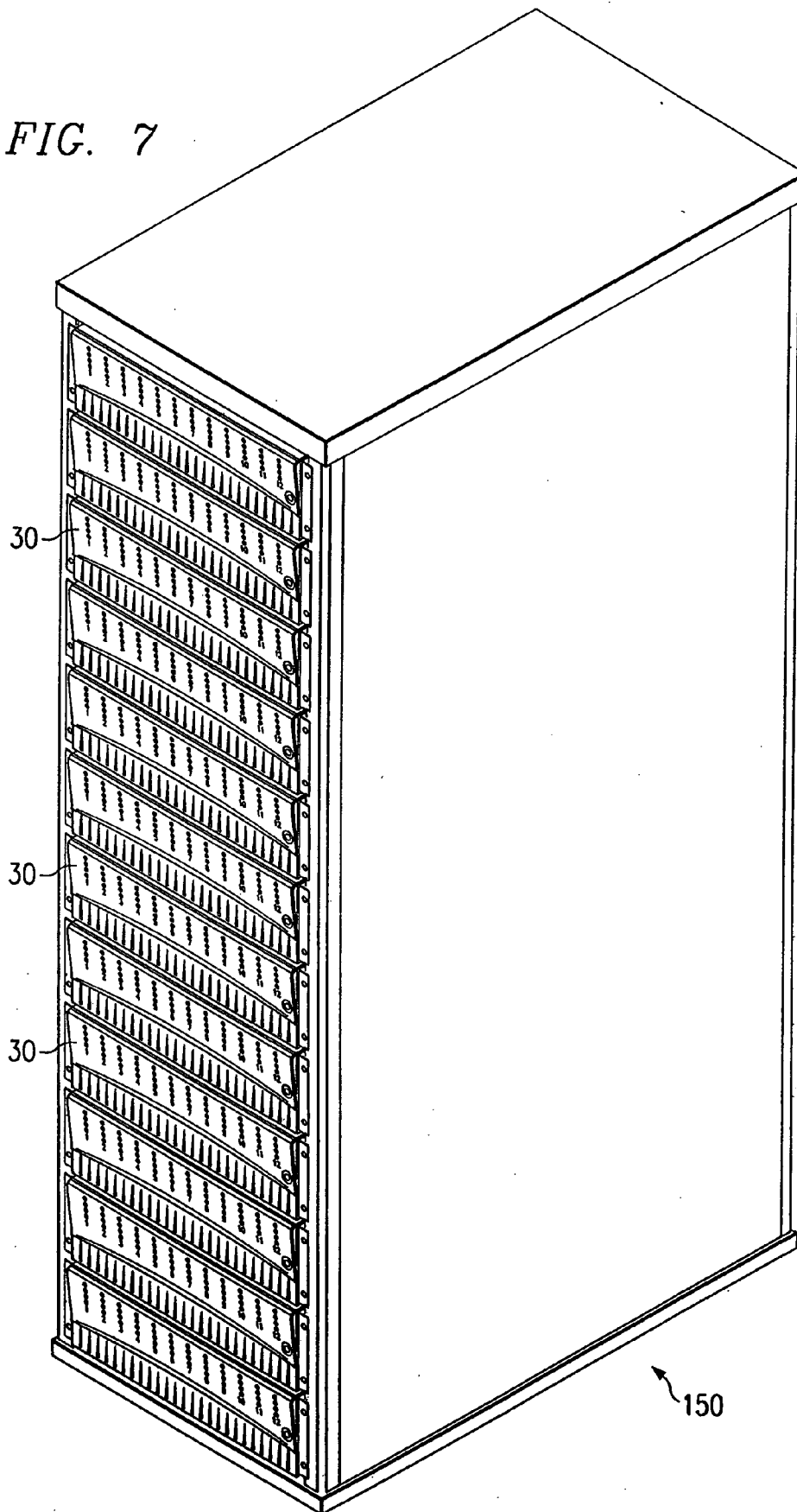
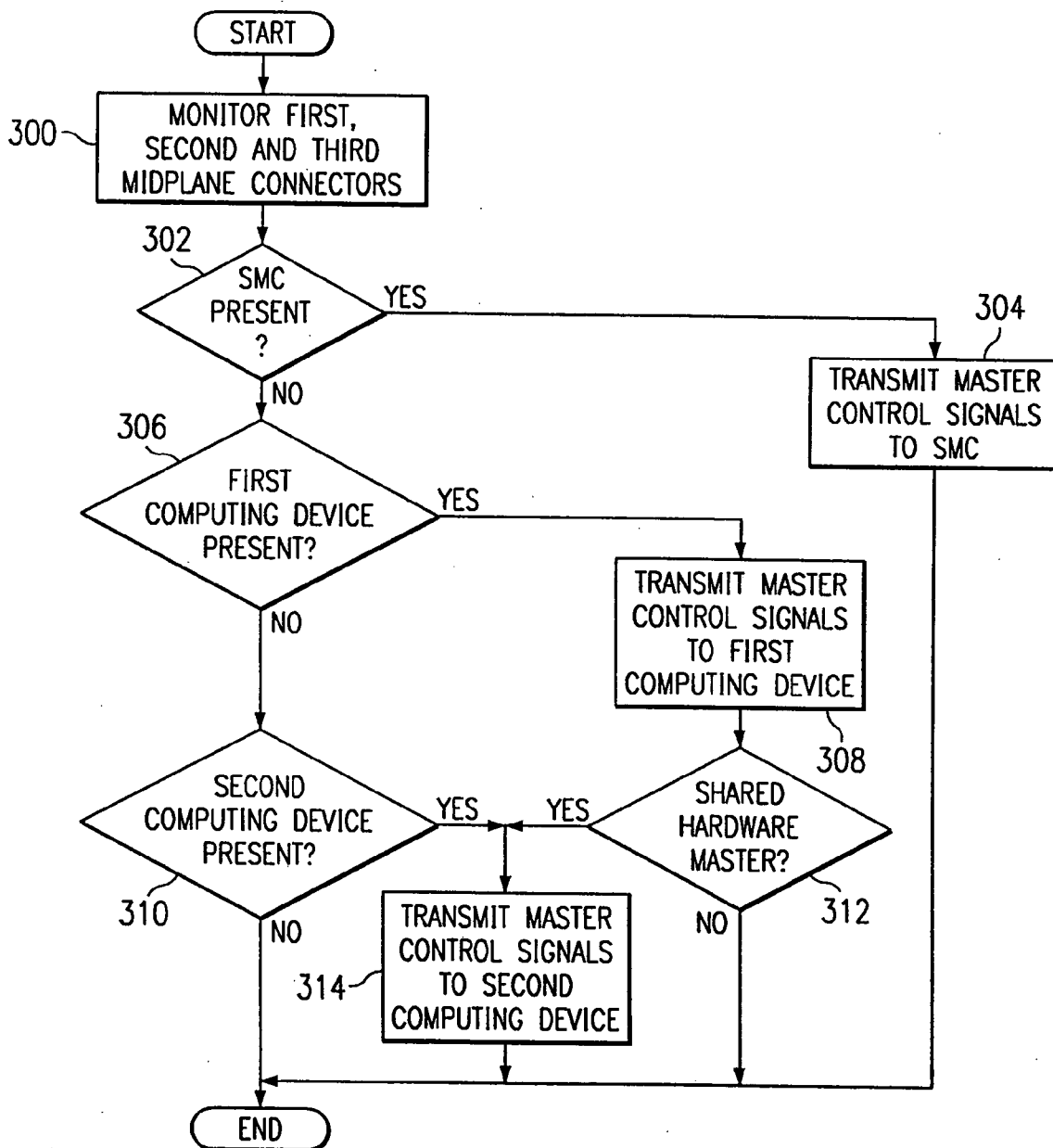

FIG. 8



EMBEDDED SERVER CHASSIS HARDWARE MASTER SYSTEM AND METHOD

RELATED APPLICATIONS

[0001] This application is a continuation of United States patent application entitled "Embedded Server Chassis Hardware Master System and Method" filed on May 4, 2001 under Ser. No. 09/848,807, now U.S. Pat. No. 6,871,300.

[0002] This application is related to United States patent application entitled "*Server Chassis Hardware Master System and Method*" filed on May 4, 2001 under Ser. No. 09/848,816 (Attorney's Docket 067856.0213).

TECHNICAL FIELD OF THE INVENTION

[0003] The present invention relates generally to server chassis communication systems and more particularly, to a chassis hardware master embedded in one or more of a plurality of servers.

BACKGROUND OF THE INVENTION

[0004] Network servers are often used for storage of information, communication, and/or to provide access to communication networks including the Internet. Users of network servers are provided the ability to view, access, retrieve and/or store audio, video, data graphics and/or text files. Such files may be displayed to the user via protocols, including, without limitation, hypertext transfer protocol (HTTP). Network servers may include one or more server processing cards coupled with a server chassis. Each server processing card may include software and/or hardware components necessary to perform the functionality of a server.

SUMMARY OF THE INVENTION

[0005] The present invention provides a system and method for at least partially monitoring and/or controlling the operation of a plurality of server processing cards. More specifically, a hardware master is selected to at least partially monitor and/or control the operation of the plurality of server processing cards. In accordance with a particular embodiment of the present invention, one or more server processing cards include a module suitable to accomplish monitoring and/or control functionality. If a particular server is selected to assume hardware master responsibilities for one or more additional server processing cards, then the module activates and assumes such responsibilities. The module associated with each server processing card which is not selected to assume hardware master responsibilities remains idle, unless it is selected at a later time.

[0006] According to one aspect of the present invention, a method for monitoring a plurality of server processing cards of a server chassis includes selecting at least one hardware master from among a plurality of server processing cards. A hardware master control signal may be transmitted to the hardware master. A hardware master module coupled with the hardware master may activate in response to the master control signal. The hardware master may be operable to monitor operating information regarding at least a subset of the plurality of server processing cards. In particular embodiments, the operating information may include health and/or configuration data associated with the subset of the plurality of server processing cards.

[0007] According to another aspect of the present invention, the hardware master may be operable to control the operation of the subset of the plurality of server processing cards. The control may include transmitting, from the hardware master, a command to at least one of the subset of the plurality of server processing cards operable to cause the at least one of the subset to reboot. In a particular embodiment, the hardware master may transmit to at least one of the subset of the plurality of server processing cards a command operable to cause the at least one of the subset to reboot from an operating system resident upon a remote module of a local area network.

[0008] Technical advantages of particular embodiments of the present invention include a plurality of server processing cards each including a module operable to assume hardware master responsibilities with regard to one or more additional server processing cards. Accordingly, a hardware master may be selected from one of a plurality of server processing cards. Furthermore, a backup hardware master may be selected to assume hardware master responsibilities in the event of a failure of the previous hardware master.

[0009] Another technical advantage of a particular embodiment of the present invention includes a plurality of server processing cards including the ability to share hardware master responsibilities. A redundant configuration of hardware masters may be provided to limit the impact of a failed server processing card on overall hardware master responsibilities. Additionally, two or more server processing cards may divide hardware master responsibilities amongst themselves, in order to limit the load and/or responsibility of any particular server processing card.

[0010] Other technical advantages of the present invention will be readily available to one skilled in the art from the following figures, descriptions, and claims.

BRIEF DESCRIPTION OF THE DRAWINGS

[0011] For a more complete understanding of the present invention and its advantages, reference is now made to the following descriptions, taken in conjunction with the accompanying drawings, in which:

[0012] **FIG. 1** is an isometric view, with portions broken away, illustrating a server chassis in accordance with a particular embodiment of the present invention;

[0013] **FIG. 2** is an isometric view, with portions broken away, illustrating the server chassis of **FIG. 1**;

[0014] **FIG. 3** is a partial wiring and control diagram, with portions broken away, illustrating a midplane coupled with a network interface card and a plurality of server processing cards, in accordance with a particular embodiment of the present invention;

[0015] **FIG. 4A** is a schematic drawing, with portions broken away, illustrating the front view of a midplane, in accordance with a particular embodiment of the present invention;

[0016] **FIG. 4B** is a schematic drawing, with portions broken away, illustrating a rear view of the midplane of **FIG. 4A**;

[0017] **FIG. 5** is a schematic drawing, with portions broken away, illustrating a server processing card of the

server chassis of **FIG. 1**, in accordance with a particular embodiment of the present invention;

[0018] **FIG. 6A** is a schematic drawing, with portions broken away, illustrating a network interface card in accordance with a particular embodiment of the present invention;

[0019] **FIG. 6B** is a schematic drawing, with portions broken away, illustrating a network interface card in accordance with an alternative embodiment of the present invention;

[0020] **FIG. 7** is an isometric view, illustrating a server rack having a plurality of server chassis, in accordance with a particular embodiment of the present invention; and

[0021] **FIG. 8** is a flow diagram illustrating a method for selecting a hardware master and distributing control signals, in accordance with a particular embodiment of the present invention.

DETAILED DESCRIPTION OF THE INVENTION

[0022] **FIGS. 1 and 2** illustrate a high-density, multiple server chassis **30**, in accordance with a particular embodiment of the present invention. Server chassis **30** includes a plurality of server processing cards **32-44** coupled with a midplane **46**. A plurality of network interface cards **47-51** are also coupled with midplane **46** and provide processing cards **32-44** with access to one or more attached communication networks. Server processing cards **32-44** provide the functionality of single board computers which may be employed as rack mounted servers. Server chassis **30** and midplane **46** are adapted to receive up to twenty-four server processing cards and provide access to as many as four independent networks, including the Internet. In a particular embodiment to be described later in more detail, one or more network interface cards **47-51** may include an attached single board computer “daughter card”. The number of server processing cards and/or network interface cards included with server chassis **30** may vary significantly within the teachings of the present invention. For illustrative purposes, twelve server processing cards **32-43** are included in **FIG. 1**. An additional processing card **44** is illustrated in **FIG. 2**.

[0023] In accordance with a particular embodiment, one or more hardware masters are selected from server processing cards **32-44** and/or network interface cards **47-51** to at least partially monitor, control, and/or record historical operating data regarding the operation of various components of server chassis **30**. The hardware master includes a module with the ability to monitor and control such components. For example, in a particular embodiment, the hardware master is a repository of health and configuration data regarding its associated server chassis components. The hardware master may also include active control features including hardware, software, and/or password resets, booting and updates. One or more server processing cards **32-44** and/or network interface cards include suitable hardware, software and/or logic for performing hardware master responsibilities. In the illustrated embodiment, passive midplane is configured to detect the presence of server processing cards and/or network interface cards and select the appropriate hardware master(s) based upon a predetermined management hierarchy.

[0024] Each server processing card **32-44** is at least partially enclosed within a box build **52**. A hinged articulating door **54** is operable to enclose each server processing card **32-44** within box build **52**, and provide access to server processing cards **32-44**, as needed for provisioning, service, maintenance, and/or replacement.

[0025] A plurality of box fans **56-61** coupled with articulating door **54** are operable to provide airflow adjacent each server processing card **32-44**, for cooling purposes. Each fan **56-61** may be configured to run at a relatively high speed if any one of processing cards **32-44** detect the need for additional airflow and/or cooling for one or more of its associated components (e.g. “high-temperature condition”). Accordingly, one or more fans **56-61** may be actuated to one of at least three operating speeds in response to the operating characteristics of one or more components of server processing cards **32-44**.

[0026] In the illustrated embodiment, a plurality of operating temperatures associated with components of each server processing card **32-44** are periodically monitored and used to determine the appropriate operating speed for box fans **56-61**. The hardware master may be operable to at least partially monitor, record, store and/or control the operation of fans **56-61**. Accordingly, in particular embodiments, the hardware master may monitor a plurality of temperature sensors included within server chassis **30** and actuate the fans as needed for cooling. The hardware master may also be operable to detect failure of a fan(s) and/or other components of server chassis **30**.

[0027] Box build **52** includes a base **62** forming a lower portion of box build **52**. In the illustrated embodiment, box build **52** and base **62** are fabricated from plated steel. Box build **52** and articulating door **54**, in combination, provide the ability to protect server processing cards **32-44** from ambient environment and/or damage. When articulating door **54** is in the closed position, box fans **56-61** may be used to draw air from the ambient environment, through articulating door **54**. The air is exhausted through a back plate **64** of box build **52**. In a particular embodiment, each box fan **56-61** includes a tachometer output having an interface coupled with midplane **46**, and the interruption of service of any particular fan may be automatically and promptly detected. The hardware master may be operable to monitor the tachometer(s) and detect such interruption of service.

[0028] Articulating door **54** includes a printed circuit board (“PCB”) **66** which allows for the viewing of LED indicator lights associated with server processing cards **32-44**, by an operator standing in front of articulating door **54** (opposite server processing cards **32-44**). Recessed windows **68** include slightly “smoked” translucent material, such that the associated LED indicator lights are reasonably visible through articulating door **54**.

[0029] In the illustrated embodiment, server chassis **30** measures approximately 17.3 inches wide by 25.5 inches deep, by 5.25 inches high. The environmental operating temperature is within the approximate range of 0° C. to 40° C. (32° F. to 104° F.). The hardware master is operable to periodically record, and/or store the environmental operating temperature. Server chassis **30** may be operated at altitudes exceeding ten thousand feet above sea level.

[0030] Midplane **46** includes two power supply mounting mechanisms **90** (see **FIGS. 4A and 4B**), which facilitate the

installation of two load-balance, hot-swappable power supplies **92**. Power supplies **92** are installed upon backplate **64** with mechanical fasteners, for example, thumbscrews. Each power supply **92** includes enough power to operate a fully populated (e.g. twenty-four server processing cards) midplane **46**, in case one of the two power supplies **92** fails. Accordingly, server chassis **30** may be operated using a single power supply **92**, with an optional upgrade to a second power supply. The hardware master is operable to detect the presence of the power supply(s) and determine their respective specifications/capabilities. The hardware master may also be operable to detect power supply failures and/or determine the distribution of power supplied by power supply(s) **92** according to the power available from one or both.

[0031] Power supplies **92** are considered load balanced because they include "auto sensing" capabilities. Each power supply **92** has the ability to sense the load required of it. In the illustrated embodiment, printed circuitry associated with midplane **46** evenly distributes the necessary power consumption load between power supplies **92**. This distribution of power and auto-sensing may be monitored by the hardware master. In a particular embodiment, power supplies **92** will each supply approximately one-half of the necessary power (current) to midplane **46** if each power supply **92** is properly connected and fully operational. If service from one power supply **92** is diminished, or becomes unavailable, the other power supply **92** and/or the hardware master will sense this and cause the other power supply **92** to provide the power necessary for midplane **46** to operate at full capacity. In another embodiment, power supplies **92** and midplane **46** may be provided with the printed circuitry necessary to allow power supplies **92** to communicate with one another, the hardware master, and/or other components of chassis **30** regarding their load sharing responsibilities, and report trouble and/or diminished capacity to one another.

[0032] Articulating door **54** of chassis **30** includes a chassis intrusion sensor associated with printed circuit board **66**. Each power supply **92** includes an integral circulation fan. When articulating door **54** is opened, a circuit is closed which forces the circulation fan(s) to a HIGH setting. Each power supply **92** includes an associated interface which allows this wiring configuration. This is done to compensate for the loss of airflow from fans **56-61** due to articulating door **54** being opened. In this manner, additional airflow through power supplies **92** at least partially compensates for the loss of airflow through fans **56-61**, and additional airflow is drawn across each server processing cards. When articulating door **54** is closed, the fans associated with power supplies **92**, return to their previous setting. In a particular embodiment, the hardware master may be operable to monitor the intrusion alarm and/or control the fans associated with the power supplies as described above.

[0033] FIG. 3 is a schematic drawing, with portions broken away, illustrating two server processing cards **32** and **33**, midplane **46**, and network interface card **51**. Each server processing card **32** and **33** includes a master control module **70** and **71**, respectively. Network interface card includes a control module **72**. Each of control modules **70-72** include hardware, software and/or logic for performing hardware master responsibilities. However, in a particular embodiment of the present invention, only one of control modules

70-72 is selected to perform the hardware master responsibilities at any given time. The selected control module may be referred to as the master control module. In an alternative embodiment, one or more control modules **70-72** may share hardware master responsibilities. The control module may be selected according to a predetermined hierarchy, which depends upon the hardware configuration of server chassis **30** at any given time.

[0034] Midplane **46** includes a master signal control module **74**. Server processing cards **32** and **33** are coupled with master signal control module **74** using communication links **76** and **77**, respectively. Network interface card **51** is coupled with master signal control module **74** using communication link **78**. Master signal control module **74** includes hardware, software and/or logic to determine which control module of **70-72** will assume hardware master responsibilities, and master signal control module **74** distributes master control signals over one of communication links **76-78** accordingly.

[0035] Master signal control module **74** includes the ability to detect which hardware components are coupled with midplane **46**. A predetermined hierarchy of hardware masters is included with master control module **74** to allow master control module to select the appropriate hardware master. Therefore, at any given instance, for example at system startup, master signal control module **74** determines which hardware component should assume hardware master responsibilities. In the illustrated embodiment, the priority for hardware master is selected according to the following hierarchy: (i) network interface card **51**; (ii) server processing card **32**; and (iii) server processing card **33**. This particular hierarchy is determined according to which connector **45** a particular server processing card is coupled with.

[0036] If network interface card **51** is coupled with midplane **46**, then network interface card **51** assumes hardware master responsibilities. If master control module **46** determines that network interface card **51** is not present, then hardware master responsibilities are delegated to server processing card **32**. Similarly, if neither network interface card **51** nor server processing card **32** are present, then hardware master responsibilities are delegated to server processing card **33**. The particular hierarchy, or priority for hardware master may be modified within the teachings of the present invention, to suit any hardware configuration and/or hierarchy scheme.

[0037] In accordance with a particular embodiment of the present invention, each control module **70-72** includes a respective master signal input to monitor its respective communication link **76-78** with master control module **74** to determine if master control signals are being received. If any particular control module of **70-72** determines that master control signals are not being received from master signal control module **74**, then that particular control module of **70-72** remains idle. If master control signals are being received, then whichever control module of **70-72** is receiving the master control signal executes and/or becomes active in order to assume hardware master responsibilities.

[0038] In the illustrated embodiment, since each of network interface card **51**; and server processing cards **32** and **33** are present, master signal control module **74** will appoint control module **72** (if present) as hardware master, and deliver master control signals to control module **72**. Control

module **72** detects the presence of master control signals on communication link **78**, and control module **72** executes and assumes hardware master responsibilities. Since master control signals are not being transmitted over communication links **76** and **77**, neither of control modules **70** or **71** will detect master control signals. Therefore, in this embodiment, control modules **70** and **71** will remain idle and server processing cards **32** and **33** will operate subject to the control of the hardware master, namely, network interface card **51**. Server processing cards **32** and **33** will also report various configuration and health information to control module **72** to allow control module **72** to conduct its hardware master responsibilities.

[0039] The hardware master is responsible for control of various hardware components of server chassis **30**. Furthermore, the hardware master monitors, collects and stores health and configuration data regarding various components of server chassis **30**. The hardware master also transmits some or all of this information to other components of server chassis **30** and/or an attached network upon request, or according to a predetermined reporting scheme.

[0040] Health data regarding various components of server chassis **30** may include such information as the operating temperature of any given component and/or temperature sensor, voltage, fan speeds, disk drive health or performance, and/or power supply activity. Therefore, the hardware master can determine failures of particular components, and/or impending failure of particular components.

[0041] Configuration data regarding server chassis **30** includes information including which components are present, the hardware and/or software resident on a given component, unique identifiers regarding the components, capacities, remaining capacities and/or capabilities. For example, in the illustrated embodiment, each server processing card **32-44** may include one or more different operating systems. The hardware master can determine which operating system(s) are present upon each particular server processing card **32-44**. The hardware master also determines which of server processing cards **32-44** are coupled with midplane **46** and which of connectors **45** of midplane **46** are vacant. Similarly, the hardware master determines which of network interface cards **47-51** are coupled with midplane **46**, and which network interface card connectors are vacant. The hardware master also determines which power supplies are coupled with midplane **46**, and which power supply mounting mechanism(s) is vacant.

[0042] If a given server processing card **32-44** is coupled with midplane **46**, the hardware master can establish which hardware components are included with the particular server processing card. Such information includes the size of the disk drive(s) attached to the server processing card, capacity, remaining capacity, speed, and unique identification number. The hardware master also can establish the specification of the central processing unit attached to the server processing card. In fact, the hardware master includes the ability to detect all hardware components associated with the server processing card and their respective specifications, capabilities, capacities and unused capacities of each component.

[0043] In a particular embodiment of the present invention, master signal control module **74** includes a plurality of diodes and resistors which accomplish the logic necessary to determine the identity of the hardware master and distribute

master control signals accordingly. In this particular embodiment, master signal control module **74** does not include other hardware components such as integrated circuits.

[0044] Each server processing card **32** and **33** also includes all of the components, features, and functionality of all server processing cards described herein. Therefore, if master control signals are not being received at either of server processing cards **32** and/or **33**, then they continue to function as server processing cards subject to the control of the hardware master. In fact, even when a particular server processing card is functioning as hardware master, that particular server processing card continues to function as a server processing card and continues to include the features and functionality of a standard (e.g. non hardware master) server processing card using available resources which are not dedicated to performing hardware master responsibilities.

[0045] In a particular embodiment of the present invention, midplane **46** includes a command bus **80**, a control bus **82**, and I²c bus **83**. Each of command bus **80**, control bus **82**, and I²c bus **83** may be used to communicate signals with each component which is coupled with midplane **46**. More specifically, in accordance with a particular embodiment, each of command bus **80**, control bus **82**, and I²c bus **83** may be coupled with each server processing card **32-44**.

[0046] The hardware master selected from network interface card **51** and server processing cards **32** and **33** controls components of server chassis **30** using command bus **80**, control bus **82**, and/or and I²c bus **83**. In a particular embodiment, command bus **80** includes an RS-485 bus. The hardware master includes the ability to perform remote resets (e.g. reboot) of any particular server processing card using the control bus **82**.

[0047] In accordance with a particular embodiment, the hardware master may cause any particular server processing card to reboot from an attached hardware component of a network coupled with server chassis **30** through one of network interface cards **47-51**. Control bus **82** may also be used to detect the presence of a server processing card in any of connectors **45**.

[0048] In a particular embodiment, server processing cards **32** and **33** may share hardware master responsibilities. For example, server processing cards **32** and **33** may be configured to assume active and standby roles with respect to hardware master responsibilities. A communication link **84** may be provided between communication links **76** and **77** for this embodiment. When communication link **84** is present, each of server processing cards **32** and **33** will receive control signals from master signal control module **74**, if network interface card **51** is not present. Control modules **70** and **71** may be configured to determine which control module will assume hardware master responsibilities. Accordingly, a communication link **85** is provided between server processing cards **32** and **33**. Communication link **85** allows control modules **70** and **71** to communicate regarding their shared hardware master responsibilities.

[0049] FIGS. **4A** and **4B** illustrate components of midplane **46**. On its front face **100**, midplane **46** includes a plurality of server processing card connectors **45** which facilitate the installation of up to twenty-four server pro-

cessing cards **32**. In a particular embodiment, server processing card guides are installed at 0.7 inch center to center dimensions. Alternatively, up to twelve server processing cards **32** including optional three and one-half inch disk drives may be installed upon midplane **46**, using every other connector **45**.

[0050] Rear face **102** of midplane **46** includes a pair of power supply mounting mechanisms **90** which accommodate the coupling of power supplies **92** with midplane **46**. Rear face **102** of midplane **46** also includes a plurality of network interface card connectors **104-109**. Midplane **46** of server chassis **30** includes all of the power and connectivity requirements to accommodate up to twenty-four server processing cards.

[0051] In a particular embodiment, midplane **46** of the illustrated embodiment is considered "passive" because it includes no active components (e.g., powered integrated circuits) which can fail. Instead, midplane **46** includes the necessary wiring to connect each respective server processing card **32** with its corresponding network interface card. Midplane **46** includes the appropriate printed circuitry to distribute data and power necessary for the operation of server chassis **30**. The distribution of data and power is monitored and/or controlled, at least in part, by the hardware master. For example, midplane **46** distributes power to components of server processing cards **32**, network interface cards **104-109**, and/or PCB **66**. Additionally, midplane **46** distributes data and/or communications signals between server processing cards **32**, network interface cards **104-109** and/or PCB **66**.

[0052] Midplane **46** also includes a ribbon cable connector **134** which couples PCB **66** with midplane **46**. Connector **134** and the hardware master are operable to distribute power and communicate control signals between midplane **46** and PCB **66** of chassis **30**. This accommodates the operation of the PCB **66**, fans **56-61** and LEDs associated with articulating door **54**.

[0053] FIG. 5 is a schematic drawing, with portions broken away, illustrating server processing card **32** in accordance with a particular embodiment of the present invention. Server processing card **32** is a single board computer upon which components and devices are mounted to enable processing card **32** to function and operate as a server hosting a wide array of Internet-based applications. Each server processing card **32** within a particular chassis **30**, shares a common midplane **46** through which power and connectivity passes. Server chassis **30** is intended for rack mount in server rack **150** (See FIG. 7), and includes midplane **46** and all the associated server processing cards **32**.

[0054] In one embodiment, server processing card **32** includes a powerful computer connected to the Internet and operable to store audio, video, data graphics and/or text files in order to display to a user of public network **46** via protocols including, without limitation, hypertext transfer protocol (HTTP). Each server processing card **32** includes a printed circuit board **120**, coupled with a central processing unit (CPU) **122**, a disk drive **124**, a dynamic memory integrated circuit **93**, and network interface integrated circuitry **128-130**.

[0055] Central processing unit **122** performs the logic, computational and decision making functions of processing

card **32**. Many types of central processing units with various specifications may be used within the teachings of the present invention. In the illustrated embodiment, CPU **122** includes a Crusoe™ 5600, 633 MHz CPU, as manufactured by Transmeta. In fact, many central processing units with comparable processing power to a Pentium III, as manufactured by Intel, may be used within the teachings of the present invention. For example, the Crusoe™ 5800 may also be used.

[0056] CPU **122** of the present invention may include the ability to adapt its processing speed to the processing load placed upon it. In other words, CPU **122** may vary its speed as appropriate to handle any given processing load, whereas many other processors simply include ON or OFF capabilities. The CPU **122** of the present invention may include a maximum continuous power consumption of no more than five watts, and a maximum operating temperature of below 150 degrees Fahrenheit.

[0057] In the illustrated embodiment, the maximum operating temperature of CPU **122** is approximately 120° Fahrenheit. Due to its variable speed feature CPU **122** of the present invention will typically consume significantly less than five watts of power. CPU **122** of the illustrated embodiment is compatible with the Intel instruction set such that CPU **122** supports standard X86 operating system.

[0058] Disk drive **124** includes electronics, motors, and other devices operable to store (write) and retrieve (read) data on disk media. In the illustrated embodiment, disk drive **124** includes a two and one-half inch IBM 9.5 mm notebook hard drive. A second two and one-half inch disk drive **125** may be installed upon a given server processing card **32**. The use of disk drive **125** is optional, and increases the capacity and functionality of server processing card **32**, and allows for drive data redundancy.

[0059] A plurality of hardware connectors are provided upon printed circuit board **120**, to allow for the installation of up to two, two and one-half inch disk drives. For example, communication ports **95** are affixed to printed circuit board **120**, to allow for the installation of disk drives **124** and/or **125**. Each disk drive **124** and **125** is also affixed to printed circuit board **120**, using connectors **97**.

[0060] The use of server processing card **32** having two, two and one-half inch disk drives allows for the installation of three hundred and thirty-six servers within an industry standard rack having 42U of usable interior space (standard industry rack). For purposes of this specification, a standard industry rack has the approximate dimensions of nineteen inches wide by six feet high by thirty to thirty-four inches deep.

[0061] Furthermore, at least two, 5 to 30 gigabyte—two and one-half inch hard drives may be provided with server processing card **32**, in accordance with the teachings of the present invention. Alternatively, a 10 to 75 gigabyte, three and one-half inch hard drive may be installed upon server processing card **32**, in lieu of two and one-half inch drives **124** and **125**. Many other hard drives are suitable for use within the teachings of the present invention. In fact, many hard drives having a maximum operating temperature of 125° F. and a maximum continuous power output of 2.5 watts may be substituted for disk drive **124** of the present invention. Accordingly, a plurality of configurations for server processing cards **32** are envisioned within the teachings of the present invention.

[0062] In another embodiment, each server processing card **32** is equipped with a single, three and one-half inch disk drive, which offers greater spindle speed and product life. Alternatively, two and one-half inch disk drives provide greater density and lower power requirements. In a particular embodiment, the three and one-half inch disk drive may include an IBM DeskStar or the two and one-half inch disk drives may include an IBM TravelStar hard drive. A total of one hundred and sixty-eight server processing cards having a three and one-half inch disk drive may be mounted in a standard industry rack.

[0063] Server processing card **32** also includes a dynamic memory integrated circuit, or memory **93**. Memory **93** includes a dual in-line memory module (“DIMM”), to provide the appropriate speed and bandwidth for network communication. In a particular embodiment, memory **93** includes a standard one hundred and sixty-eight pin connector. The storage capacity of memory **93** may be approximately 64 MB RAM, or greater.

[0064] Three interface integrated circuit chip sets **128**, **129** and **130** are coupled with printed circuit board **120**. Chip set **128** may be referred to as public network interface integrated circuit since it corresponds with the operation of the public network. Similarly, chip set **129** may be referred to as the private network interface integrated circuit and chip set **130** may be referred to as the management network interface integrated circuit since they correspond to private network and management network operations, respectively. Collectively, chip sets **128**, **129** and **130** may be configured to provide three 10/100/1000 megabits per second Ethernet network interfaces. Additional chip sets may be included with server processing card **32** in order to support more than three independent networks. Chip sets **128-130** may be used for communication between server processing cards **32** and network interface cards **47-51**.

[0065] Each chip set **128**, **129** and **130** also includes “boot from LAN” capability. Boot from LAN refers to the ability of server processing card **32** to reboot from an attached network device, rather than rebooting from hardware and/or software integrated to server processing card **32**. This may be used to provide software updates, new and/or revised versions and/or troubleshooting. In a particular embodiment of the present invention, any of server processing cards **32-44** may receive a command to boot from LAN. This command may be generated by the hardware master of a given session. When this command is received, the next time server processing card **32** reboots, it will do so from an attached network component. The server processing card will continue to boot from LAN until it receives a command to boot from disk.

[0066] A high density, 80 pin SCA connector **94** is used to couple server processing card **32** with a corresponding high density, 80 pin SCA connector **45** associated with midplane **46**. Connector **94** includes a “blind mate” feature which provides self-alignment properties for simplified installation and removal of processing card **32** from passive midplane **46**. Connector **94** also includes pins suitable for hot swap insertion and extraction of server processing cards **32-144**. Connectors **94** and **45** also include built-in serial connectors for managing network traffic. In other words, connectors **94** and **45** are appropriately sized and configured to accommo-

date a serial connection independent of the above referenced Ethernet connections and any other required power/communications ports.

[0067] Server reset button **112** of server processing card **32** may be used to accomplish a “hard” local reset of the associated processing card **32**. A password reset button **114** is also provided and may be used to locally reset the administrative password. In other words, password reset button **114** may be used to erase the existing administrative password such that an operator of network **30** may redefine the administrative password. The hardware master may be used to monitor the use of resets **112** and/or **114**.

[0068] A dual in-line memory module (DIMM) connector **93** is also provided upon server processing card **32**. In the illustrated embodiment, DIMM connector **93** includes a multiple pin connector. The size and configuration of DIMM connector **93** may be significantly altered, within the teaching of the present invention. DIMM connector **93** facilitates the installation of a dual in-line memory module(s) DIMM(s). Accordingly, server processing card **32** can accommodate significantly more bandwidth than traditional systems which incorporate a single in-line memory module (SIMM). The hardware master may be used to detect the presence, specifications, and/or capacities associated with the attached DIMM.

[0069] Server processing card **32** also includes a custom Basic Input/Output System (“BIOS”) which contains the appropriate instructions for system initialization. The BIOS of the illustrated embodiment is capable of supporting communication with at least three independent networks. The BIOS is also configured to support the “Boot from LAN” capability described above. Many of the other components of server processing card **32** are similar in structure and function to a typical motherboard, although support for video, keyboard and a mouse may be removed. Each server processing card **32** may include two megabytes of flash read-only-memory (ROM) for BIOS storage.

[0070] As previously described, each server processing card may have either a three and one-half inch disk drive installed, a two and one-half disk drive, or two, two and one-half inch disk drives installed. Standard three and one-half inch disk drives use primarily 12 volt power and standard two and one-half inch disk drives use 5 volt power. Accordingly, 5 and 12 volt loading by each server processing card may be very different depending on the type and/or size of disk drives installed. In previous web servers, the variation in loading between the 5 and 12 volt supplies would have required the use of different power supplies depending on the type of disk drives installed, or the use of much larger power supplies to compensate for the wide variation in 5 and 12 volt loading.

[0071] Server processing cards **32** eliminate these problems by balancing to some degree the loading on the 5 and 12 volt supplies as follows:

[0072] The input power to a CPU DC to DC converter, installed upon server processing card **32**, is 12 volts when a two and one-half inch disk drive is installed.

[0073] The input power to the CPU DC to DC converter is 5 volts when a three and one-half inch disk drive is installed.

[0074] The input power for the CPU DC to DC converter is controlled by a disk drive power cable and is automatically configured when the appropriate cable is installed. Accordingly, server processing card **32** includes the ability to detect which type/size of disk drive is installed, and change the voltage provided to the DC to DC converter, based upon the disk drive(s) present.

[0075] This technique ensures that the power source for the CPU DC to DC converter will be properly configured because the assembly process of disk drive installation causes the DC to DC converter power source to be configured properly and no additional configuration steps are required.

[0076] In a particular embodiment, the hardware master may be operable to monitor the distribution of power, in accordance with the above description. Additionally, the hardware master will be aware of the power supplies present, the specifications associated with the power supply(s), the amount of power output each power supply is contributing at a given point in time, and any power supply failures. The hardware master is also operable to detect the presence of each hard drive(s) present, and the specifications associated with the particular disk drive(s).

[0077] FIGS. 6A and 6B illustrate network interface cards **200** and **202**, in accordance with a particular embodiment of the present invention. Network interface card **200** of the illustrated embodiment is configured to support up to twelve independent server processing cards **32**. Network interface card **200** includes twelve independent Ethernet communication paths **204** between a front connector **206** and a hub chip **208**.

[0078] Hub chip **208** consolidates management network traffic from corresponding server processing cards **32**, for distribution to an attached network. In a particular embodiment, hub chip **208** may include an integrated network hub, for example a 24-port repeater chip integrated upon interface card **200** for aggregating all management communications through a single 10/100/1000 megabits per second Ethernet connection. Hub chip **208** may be referred to as a repeater because it broadcasts, or repeats, every message it receives to all ports of the management network. In another embodiment, hub chip **208** may be replaced with a switch chip which provides the ability to address and distribute messages according to a packet header, to the appropriate port within a management network. The hub chip may be employed, in lieu of a switch chip, at network interface card **200** due to the reduced cost and simplified operation. In one embodiment, RJ-45 connectors **210** and **214** may include connectors suitable for gigabit ethernet. In another embodiment, connectors **210** and/or **214** may be replaced with fiber optic or copper gigabit interface connectors (“GBIC”).

[0079] Connector **206** includes an 80-pin SCA connector, which couples network interface card **200** with midplane **46**. Each Ethernet communication path **204** associated with network interface card **200** terminates at hub switch chip **208**. Hub chip **208** monitors and distributes traffic from a respective server processing card **32** to a corresponding RJ-45 Ethernet connector **210**, through an Ethernet communication link **212**. In a particular embodiment, a switch chip may be used in lieu of hub chip **208**. The switch chip may include an optional twelve or twenty-four port 10/100 Base

T switch with fiber gigabit uplinks. In another embodiment, the switch chip may include an optional twelve or twenty-four port 10/100 Base T switch with copper gigabit uplinks.

[0080] A redundant configuration may also be included having a second RJ-45 connector **214** and Ethernet communication link **216**. This provides the network operator with the ability to include redundant communication links to networks in separate physical locations, for emergency and/or backup operation in the event of a failure of one of the network systems.

[0081] Network interface card **200** provides modular connectivity to server chassis **30**, such that an operator of server chassis **30** may access rear connectors **210** and **214** at a convenient location upon server chassis **30**. In an alternative embodiment, a standard RJ-21 connector may be used in lieu of Ethernet connector **210** and/or RJ-45 connector **214** in order to distribute data between network interface card **200**, and corresponding server processing cards **32**, and an attached network. Accordingly, a communication link having twelve groups of two twisted pair category five cables, for a total of twelve different Ethernet connections, or forty-eight wires total, may be coupled with connector **210**. The connection between the external network and network interface card **200** may be accomplished with high density Ethernet connectors. In another embodiment, integrated 10/100/1000 switches may be incorporated using octopus cables which “fan-out” from a high density connector to multiple RJ-45 connectors.

[0082] FIG. 6B illustrates network interface card **202**. Network interface card **202** includes a single board computer **232**, coupled with a printed circuit board **231** of network interface card **202**. Single board computer **232** may also be referred to as a “daughter card” to network interface card **202**. Single board computer **232** includes similar hardware, software, and/or components to server processing cards **32**, except single board computer **232** does not include a disk drive, in the illustrated embodiment. Network interface card **202** includes a pair of high density connectors **220** and **221**. High density connectors **220** and **221** collectively include at least twelve Ethernet connectors, a command bus, control bus, I²c bus, identical status and control lines to those coupled with each server processing card, and a power interface.

[0083] The power interface associated with each high density connector **220** and **221** is configured to provide 3.3 or 5.0 volt power source to network interface card **202**. Accordingly, power may be distributed to various components of network interface card **202**, including single board computer **232**, and hub chip **222**.

[0084] The twelve Ethernet connectors **218** and **219** associated with high density connectors **220** and **221**, respectively, enable each high density connector **220** and **221** to interface with at least 12 server processing cards **32**. Accordingly, in the illustrated embodiment, each network interface card **202** can collect, interpret and manage communications and data transfer with at least 24 server processing cards **32**.

[0085] Twelve Ethernet connections **218** are used to couple high density connector **220** with hub chip **222**. Similarly, twelve Ethernet connections **219** are used to couple high density connector **221** with hub chip **222**. Hub chip **222** consolidates management network traffic from up

to twenty-four server processing cards **32**, for distribution to single board computer **232** and/or an attached network. In another embodiment, a switch chip may be used in lieu of hub chip **222** in order to provide network interface card **202** with the ability to selectively switch and distribute network management information rather than simply broadcasting all messages received to every node coupled with network interface card **202**.

[0086] A communication link **224** distributes data between hub chip **222** and an Ethernet connector **226**. Accordingly, Ethernet connector **226** may be coupled with an attached management network. In a particular embodiment, network interface card **202** may be provided without single board computer **232**.

[0087] In another embodiment, single board computer **232** may be provided with network interface card **202**, or network interface card **202** may be "upgraded" in the future to include single board computer **232**. Accordingly, connectors **234** and **236** are typically provided upon network interface card **202**, to facilitate the installation of single board computer **232**.

[0088] A communication link **230** couples hub chip **222** with an Ethernet connector **227** associated with single board computer **232**. Accordingly, when properly installed, single board computer **232** receives all broadcast signals which are received by hub chip **222**. Single board computer **232** collects, stores, calculates, analyzes and communicates this information to the attached management network and/or other components of attached networks. Communication between single board computer **232** and the attached management network occurs via Ethernet connector **228**.

[0089] When single board computer **232** and its associated Ethernet connector **228** are present upon network interface card **202**, Ethernet connector **226** is no longer required to communicate with the attached management network **70**. However, in the event of a failure of single board computer **232** and/or its associated components, including without limitation Ethernet connector **228**, Ethernet connector **226** provides an alternative path of communication between network interface card **202** and the attached management network. In an alternative embodiment, Ethernet connector **226** may be omitted from network interface card **202**.

[0090] In the illustrated embodiment, another communications link **238** is provided in order to couple single board computer **232** and high density connectors **220** and **221**. Communication link **238** may include an I²C bus, a command bus, control bus, and identical status and control lines to those coupled with each server processing card coupled with the serial port associated with high density connectors **220** and **221**. As will be described later in more detail, the control bus connection between single board computer **232** and high density connector **221** allows single board computer **232** to execute a hardware reset, software reset, or password reset upon any particular server processing card with which high density connector **221** is coupled. In a particular embodiment, communication link **238** is used to couple computer **232** with command bus **80**, control bus **82**, and I²c bus **83**.

[0091] Network interface card **202** includes the ability to perform a hardware reset of any particular server processing card **32** within chassis **30**. In a particular embodiment, single

board computer **232** collects telemetry data regarding the use, performance and operation of many components of server processing card **32** and/or other components of chassis **30**, which will be described later in more detail. Such data may be stored within single board computer **232** and/or forwarded to the attached management network, for further processing.

[0092] FIG. 7 illustrates a server rack **150** including a plurality of server chassis **30**. In a particular embodiment, each server chassis **30** consumes a total of 3U (IU=1.75 inches) of space. Accordingly, as many as fourteen server chassis **30** may be installed in an industry standard 42U rack. Each chassis **30** comes equipped with the ability to support redundant, load-balanced power supplies and RJ-21 style connectors which allow the consolidation of the requisite Ethernet cables to a significantly smaller number of cables than those required through the use of conventional RJ-45 connectors.

[0093] FIG. 8 is a flow diagram illustrating a method for selecting a hardware master and distributing control signals, in accordance with a particular embodiment of the present invention. The method begins at step **300** where three midplane connectors are monitored, in order to detect the presence of hardware components. In the illustrated embodiment, the master signal control module monitors the connectors. The master signal control module includes hardware, software and/or encoded logic operable to select the hardware master. Although the master signal control module is resident upon midplane **46**, it will be recognized by those of ordinary skill in the art that the hardware, software and/or logic may be distributed amongst various components of server chassis **30**.

[0094] Next, at step **302**, the master signal control module determines if the System Management Controller ("SMC") is present. The SMC of the present invention refers to a network interface card including a daughter board computer similar to network interface card **202**. In the illustrated embodiment, the SMC receives priority for hardware master responsibility and assumes the role of hardware master whenever it is present. Therefore, if the SMC is present, the master control signals are transmitted to the SMC at step **304**.

[0095] If the SMC is not present, the master signal control module determines if the first computing device is present, at step **306**. In the illustrated embodiment, the first computing device corresponds to server processing card **32**. If the first computing device is not present, the master signal control module determines whether the second computing device is present, at step **310**. The second computing device corresponds with server processing card **33**. If the second computing device is not present, then the method ends. If the second computing device is present, and the SMC and first computing device are not present, then the master control signals are distributed to the second computing device at step **314**.

[0096] If the first computing device is present and the SMC is not, master control signals are transmitted to the first computing device at step **308**. Furthermore, the system determines whether the first computing device, second computing device, and/or midplane are configured for a shared hardware master at step **312**. If they are not configured for a shared hardware master, then the method ends. If they are

configured for a shared hardware master, and the second computing device is present, then the control signals are also transmitted to the second computing device at step 314.

[0097] Although the present invention has been described in several embodiments, a myriad of changes and modifications may be suggested to one skilled in the art, and it is intended that the present invention encompass such changes and modifications as fall within the scope of the present appended claims.

What is claimed is:

1. A server processing card, comprising:
 - a printed circuit board;
 - a central processing unit coupled with the printed circuit board;
 - memory integrated circuits coupled with the printed circuit board;
 - network interface integrated circuitry coupled with the printed circuit board; and
 - a master control module coupled with the central processing unit, the master control module being operable to monitor a master signal input in order to detect the presence of a master control signal being communicated to the server processing card; and

wherein the master control module remains idle if the master control signal is not detected.
2. The server processing card of claim 1, wherein the master control module becomes active if the master control signal is detected.
3. The server processing card of claim 2, wherein the active master control module performs hardware master responsibilities with regard to a plurality of computing devices coupled with the server processing card within a server chassis.
4. The server processing card of claim 3, wherein the active master control module monitors health information regarding hardware components coupled with the server processing card within the server chassis, the hardware components including the plurality of computing devices.
5. The server processing card of claim 4, wherein the health information regarding the hardware components is selected from the group consisting of operating temperature, operating voltages, operating fan speed, and operating disk drive health and configuration.
6. The server processing card of claim 3, wherein the active master control module monitors configuration information regarding hardware components coupled with the server processing card, the hardware components including the plurality of computing devices.
7. The server processing card of claim 6, wherein the configuration information is selected from the group consisting of size of a disk drive, speed of a processor, unique identification numbers associated with the hardware components, memory capacity of memory integrated circuits and operating capacity of power supplies.
8. The server processing card of claim 3, wherein the active master control module monitors information regard-

ing hardware components coupled with the server chassis, the information being selected from the group consisting of health information and configuration information.

9. The server processing card of claim 8, wherein the hardware components are selected from the group consisting of power supplies, disk drives, memory integrated circuits, and cooling fans.

10. The server processing card of claim 3, wherein the active master control module includes the ability to reboot at least one of the computing devices.

11. The server processing card of claim 3, wherein the active master control module includes the ability to cause at least one of the computing devices to boot up from an operating system resident upon a remote component of a local area network.

12. The server processing card of claim 3, wherein the network interface integrated circuitry is coupled with a local area network, and the active master control module is configured to report health and configuration data regarding at least one of the computing devices to a remote component of the local area network.

13. The server processing card of claim 2, further comprising a communication coupling configured to receive a control bus and wherein the active master control module is operable to control hardware components coupled with the server processing card within a server chassis using the control bus.

14. A server chassis, comprising:

- a plurality of server processing cards each having a respective master control module;
- a midplane forming a communication coupling for communication among the plurality of server processing cards; and

wherein at least one of the plurality of server processing cards performs hardware master responsibilities with regard to at least a subset of the server processing cards.

15. A method for monitoring a plurality of server processing cards of a server chassis, comprising:

- selecting at least one hardware master from among a plurality of server processing cards, transmitting a hardware master control signal to the hardware master;
- activating a master control module coupled with the hardware master; and
- monitoring operating information regarding at least a subset of the plurality of server processing cards, from the hardware master.

16. The method of claim 15, wherein the information is selected from the group consisting of health information and configuration information regarding the operation of the subset of the plurality of server processing cards.

17. The method of claim 15, further comprising at least partially controlling the operation of the subset of the plurality of server processing cards, from the hardware master.

18. The method of claim 15, further comprising transmitting, from the hardware master, a command to at least one

of the subset of the plurality of server processing cards, the command being operable to cause the at least one of the subset to reboot.

19. The method of claim 15, further comprising transmitting, from the hardware master, a command to at least one of the subset of the plurality of server processing cards, the

command being operable to cause the at least one of the subset to reboot from an operating system resident upon a remote module of a local area network coupled with the plurality of server processing cards.

* * * * *