

(19) **DANMARK**

(10) **DK/EP 3015374 T3**



(12) **Oversættelse af
europæisk patentskrift**

Patent- og
Varemærkestyrelsen

-
- (51) Int.Cl.: **B 65 B 11/04 (2006.01)** **B 65 B 59/04 (2006.01)** **B 65 B 65/00 (2006.01)**
- (45) Oversættelsen bekendtgjort den: **2018-06-14**
- (80) Dato for Den Europæiske Patentmyndigheds bekendtgørelse om meddelelse af patentet: **2018-03-07**
- (86) Europæisk ansøgning nr.: **13888057.0**
- (86) Europæisk indleveringsdag: **2013-08-22**
- (87) Den europæiske ansøgnings publiceringsdag: **2016-05-04**
- (86) International ansøgning nr.: **CN2013082058**
- (87) Internationalt publikationsnr.: **WO2014205908**
- (30) Prioritet: **2013-06-27 CN 201320378884 U** **2013-06-27 CN 201310266617**
- (84) Designerede stater: **AL AT BE BG CH CY CZ DE DK EE ES FI FR GB GR HR HU IE IS IT LI LT LU LV MC MK MT NL NO PL PT RO RS SE SI SK SM TR**
- (73) Patenthaver: **Hangzhou Youngsun Intelligent Equipment Co., Ltd., No.1 Western Garden, 9th Road the West, Lake Science and Xihu, Technology Zone , Hangzhou, Zhejiang 310030, Kina**
- (72) Opfinder: **LUO, Bangyi, No.1 Western Garden 9th Road, The West Lake Science and Technology Zone, Xihu, Hangzhou, Zhejiang 310030, Kina**
- (74) Fuldmægtig i Danmark: **Patrade A/S, Ceresbyen 75, 8000 Århus C, Danmark**
- (54) Benævnelse: **Viklemaskine**
- (56) Fremdragne publikationer:
EP-A1- 1 334 909
EP-A2- 1 092 627
WO-A2-2009/087600
CN-A- 101 503 118
CN-U- 201 660 133
CN-U- 201 660 134
JP-A- 2001 171 618
US-A1- 2008 289 298
US-A1- 2012 175 170

DESCRIPTION

FIELD OF THE INVENTION

[0001] The present invention relates to a winding machine.

BACKGROUND OF THE INVENTION

[0002] The winding machine is a mechanical device used in the field of packaging machinery, which is used for wrapping packaging membrane on the surface of articles. The winding machine comprises an upright column, a turntable and a membrane frame. Articles are placed on the rotary mechanism which rotates with the rotary mechanism. The packaging film roll is mounted on the membrane frame, which is connected at the hoisting apparatus of the upright column for ascending and descending movement, and cut off by the membrane cutting element at the end of winding. The upright column is hollow, with the electrical control part of the winding machine. The winding machine is large, with special shape. The improvement goal of the winding machine is to achieve comprehensive improvement in transport, assembly and use, etc., for example, the relationship between the shape, volume and hollow of upright column. The operation convenience of site installation and the ease of transport is always a contradiction difficult to resolve. At present, most upright column housing adopts the welding way; although it can be assembled and welded in the factory, the upright column housing is a thin board, difficult to weld, and its shape is not nice after welding, nor disassembled as needed.

[0003] Further attention is drawn to CN101503118, disclosing a winding machine, belonging to the technical field of packing machinery. The winding machine of CN101503118 comprises a housing case, a lifting frame slide groove, a lifting frame raising mechanism, a lifting frame, a film transferring mechanism, a base, a turn plate and a position-limit mechanism.

[0004] Attention is also drawn to CN201660134, disclosing a film clipping device in a winding machine, which comprises a film clipping device mounting plate connected with a winding machine turntable, wherein the film clipping device is provided with an air cylinder which is transversally placed and is used for clipping films, and a left film clipping part and a right film clipping part which are driven by the air cylinder, wherein the left film clipping and the right film clipping can rotate and have an opening fitting state and a film clipping fitting state.

[0005] In WO2009087600, there is provided a rotary-platform wrapping machine of the type consisting of a base body whereon there are mounted a rotary platform, rotating about a respective vertical axis, a drive motor assembly and a column which carries a system for the vertical guiding and shifting of a reel-carrying carriage.

[0006] In addition, in US2012175170 there is provided a turntable that can be used with a machine for wrapping loads with packaging material includes a turntable assembly having a first support assembly and a load support surface supported for rotation on the first support assembly.

SUMMARY OF THE INVENTION

[0007] The technical problem to be resolved in the invention is to provide a winding machine, which is convenient to transport and can be connected without welding, facilitating to the assembly and commissioning in the site. To this end, the present invention adopts the technical solution as disclosed in claim 1. The upright column cover plate is processed to a concave-convex structure by rolled reinforcement.

[0008] Further, the upright column cover plate is bent in the width direction. The upright column cross-sectional profile is in a rectangle or rectangle with corner arc transition or with corner bevel; the upright column cover plate has three faces after bent, corresponding to three facades of the rectangle of upright column. The first facade part of the upright column corresponding to the first upright column cover plate and the second upright column cover plate is connected by said bolts or screws; a groove opening for ascending and descending movement is reserved between the first upright column cover plate and the second upright column cover plate on the third facade opposite to the first facade. The upright column is also provided with a lower connection piece, and the lower connection piece is provided with the connection part at both sides of groove opening corresponding to the first and second upright column cover plates at the bottom of the upright column and the connection part corresponding to the winding machine base, which are used for connecting the part of the first and second upright column cover plates at both sides of the groove opening and winding machine base with bolts or screws when erection and installation of upright column.

[0009] Furthermore, the end of the first facade corresponding to the first and second upright column cover plates is also folded inside the upright column, and spliced at the folding and connected by bolts or screws.

[0010] The top fixed connecting piece of the upright column in the invention may also have a downward folding, which is used to fix the column cross-sectional profile, and the upright column housing main body is connected to the folding.

[0011] The top fixed connecting piece of the upright column may form a part of the top cover of the upright column, and the top mounting rack of hoisting apparatus forms another part of the top cover of the upright column.

[0012] The present invention also provides a bottom outside connecting piece. At the bottom of the upright column facade adjacent to the first connecting piece, the connection part corresponding to the winding machine base and upright column body is provided, which is

used to connect the winding machine base and upright column body, bottom inner side connecting piece by bolts or screws when erection and installation of upright column.

[0013] In the present invention, opposite to the groove opening for ascending and descending movement, the upright column is provided with a baffle board, and the bottom of which is connected with bottom inner side connecting piece by bolts or screws. The upper portion is plugged with the mounting rack at the top of the hoisting apparatus. A gap is reserved between the both sides of the baffle board and the upright column housing main body for the ascending and descending of parts.

[0014] The winding machine in the invention includes a transition piece located outside of winding machine upright column and a connecting piece located inside the upright column; the connecting piece is connected to the drive chain of the hoisting apparatus, the transition piece is connected to the connecting piece, and the membrane frame is detachably connected to the transition piece.

[0015] Further, the membrane frame is hung on the transition piece. Furthermore, the transition piece has the connection part for hanging the upper and lower membrane frames, and still furthermore, the transition piece and membrane frame are provided with the connection parts connected by screws or bolts.

[0016] The upright column is provided with guide rails for ascending and descending movement. The hoisting apparatus guide rail, hoisting apparatus supporting frame and the upright column housing main body are connected with bolts. The hoisting apparatus guide rail is located inside of the supporting frame of hoisting apparatus and fastened by bolts and nuts. The winding machine has a connecting piece, and the connecting piece is connected with the drive chain of the hoisting apparatus in the upright column, and guide part is provided at the connecting piece to match with the guide rail. The of the connecting piece is provided with a mounting groove facing outwards, and the mounting groove is provided with sliding block as the guide part, which can be adjusted front and back in the depth direction of the groove.

[0017] Further, the side surface of he connecting piece is provided with a mounting groove with the groove opening outwards, and the mounting groove is provided with sliding block as the guide part, which can be adjusted front and back in the depth direction of the groove.

[0018] Furthermore, the bottom of the mounting groove is connected with the adjusting screw, which holds out against the back of the sliding block, to adjust the sliding block front and back. Still furthermore, the clearance fit is between the sliding block and the left and right walls of the mounting groove.

[0019] Still furthermore, the mounting groove is also provided with the limiting parts of the upper and lower position of the sliding block, which is located between the upper limiting part and the lower limiting part;

[0020] Still furthermore, the clearance fit is between the sliding block and the upper limiting part.

[0021] The winding machine base is provided with two beams, which is located on both sides of the winding machine upright column transversely, and the first beam located at the side of the upright column of lifting membrane frame is shorter which forms a notch corresponding to the lifting membrane frame, and the lower end of the lifting membrane frame can be descended to the notch. The end of the upright column set with the winding machine base is provided with a fork stretching port at two beams.

[0022] Further, the end of the beam mounted the winding machine base is in a flat, peripherally closed shape with the fork stretching port in the middle.

[0023] Furthermore, the beam uses the groove-shape steel as the main body, and the groove opening is downwards. Steel plate is welded at the groove opening and at the front end of the winding machine base, a fork stretching port is formed.

[0024] Still furthermore, the winding machine base has a connection structure between two beams, to make them a whole. The second beam among the two is extended to the side of the base of the upright column of the winding machine base, and the upright column base, the second beam and the connection structure at the front of the upright column base are welded.

[0025] The winding machine base is equipped with beams and bars. The beam and bar are provided with a jack at the welding place, which is used to position the connecting location of the beam and bar. The beam is welded with the bar and the bar has the insertion site matching with the jack.

[0026] Further, the insertion site on the bar matching with the jack is the protruding part at the front of the bar.

[0027] Furthermore, the cross section of the bar is in a groove shape and the protruding part is protruding at the end of the groove bottom. Further, one or more said jacks are provided at the welding point between the beam and each bar.

[0028] Still furthermore, the winding machine base is provided with two beams at the left and right, and on both sides of each beam is welded with bars respectively.

[0029] Still furthermore, the bars welded at two beams at the left and right are symmetric relative to the center line between two beams.

[0030] The winding machine base is provided with support structure of the winding machine rotary mechanism, and the support structure includes the roller that supports the rotary mechanism, and the base of the roller shaft is in groove shape vertically and the roller shaft is arranged at the top of the groove-shape base.

[0031] Further, the groove-shape base is made by grooved steel or made by bending of steel plate.

[0032] Furthermore, the roller shaft is non-rotatable shaft.

[0033] Still furthermore, the top of groove wall made by grooved steel is provided with a groove, and the roller shaft is propped in the groove.

[0034] Still furthermore, the base is mounted on the fixing member on the side of beam welded to the beam of the winding machine base.

[0035] Still furthermore, the support structure further comprises a multiple of support members distributed circumferentially on the concentric chain wheel that drives the rotary mechanism to rotate.

[0036] A transmission mechanism is arranged at the winding machine base, and the transmission mechanism comprises a coaxial drive sprocket and drive chain of the rotary mechanism. The transmission mechanism has the fixed tensioning wheel and movable tensioning wheel relative to the chain and the movable tensioning wheel is acting on the chain by the spring tension.

[0037] Further, the movable tension wheel is mounted on the pivotable mounting member, which is connected to the spring, and the spring is mounted on the fixing member. The mounting member may be a flat object.

[0038] Furthermore, the mounting member is provided with a long limiting groove or a pair of blocking members. The transmission mechanism is equipped with a fixed arresting pin which is inserted to the long limiting groove or between the pair of blocking members. The long limiting groove or arcuate groove uses the pivot point of the mounting member as the center of circle.

[0039] Still furthermore, the fixed tensioning wheel and movable tensioning wheel are located outside of two sides of the chain loop. Further, the positions of said tensioning wheel and movable tensioning wheel are basically symmetrical relative to the axis of said drive sprocket and driving sprocket of the chain.

[0040] The upright column in the invention has a proper structure and its main body structure can be assembled in a manufacturing factory by using the bolts or the screws and is hinged with the winding machine base, and accordingly, welding operations are avoided; and the winding machine has a nice appearance and is suitable to mount, commission and transport. The main body structure of the upright column forms a solid transport assembly, and the assembly can be rotated to fall flat and conveyed with the winding machine base. The assembly is rotated and lifted up to connect with the winding machine base, which is very convenient for transport and on-site installation.

[0041] Further, the upright column connects with the membrane frame by a transition piece. The membrane frame can be easily assembled without influencing the structure of the upright column. This structure makes the installation and commissioning of upright column can be completed in the manufacturing factory. During the transport, the membrane frame is removed, to ensure that the membrane frame is not damaged; and in the assembly site, just simply mount it, without other assembly and commissioning of the upright column structure, which can greatly reduce the workload and avoid the repeated work.

[0042] Furthermore, the lifting guide mechanism of the upright column in the invention has a simple structure, applicable for small upright column of winding machine, which can achieve lifting and descending by a single chain drive. Moreover, further, the guide mechanism can be adjusted back and forth, and achieve adaptive adjustment in the horizontal and vertical directions, lowering the matching requirements of the lifting guide mechanism for surrounding structures and achieving effective operation for a long time. In addition, the lifting guide mechanism of the present invention employs sliding block approach, which is easy to replace and install, with low costs.

[0043] Still furthermore, the lifting membrane frame of the winding machine base can lower to he notch during the operation of the winding machine, which can lower much than before, expand the operating range of the winding machine, and lower the minimum membrane-winding height; moreover, the present invention can be inserted from the rear end with a forklift, making it safer and more convenient.

[0044] Still furthermore, the winding machine base employs the jack positioning when welding the beam and bars, which can facilitate the positioning of the bar, simplify the welding process and reinforce the welding structure, improving the quality of welding.

[0045] The structure of the winding machine employing the technical solutions in the invention is compressively improved in the transport, assembly and use.

BRIEF DESCRIPTION OF THE DRAWINGS

[0046]

FIG. 1 is the overall scheme of an example of the winding machine in the invention.

FIG. 2 is the overall scheme of the example in FIG.1 in another direction.

FIG.3 is the exploded view of the upright column in the invention.

FIG. 4 is the schematic diagram of upright column cover plate, hoisting apparatus supporting frame and guide rail bolt in Example 3 in FIG.3.

FIG.5 shows an installation way of membrane frame and the schematic diagram of the lifting

guide mechanism in the invention.

FIG.6 is the schematic diagram of the mode of execution in another direction as shown in FIG.5.

FIG.7 is the exploded view of FIG.5.

FIG.8 is the overall schematic diagram of an example in the invention.

FIG.9 is the schematic diagram of the example shown in FIG.8 in another direction.

FIG.10 is the schematic diagram of the example of winding machine base provided in the invention.

FIG.11 is the exploded diagram of beam and bar in FIG.10.

FIG.12 is the exploded view of winding machine base and rotary mechanism in the example provided in the invention.

FIG.13 is the combined schematic diagram of roller and its groove-shape base in FIG.12.

FIG.14 is the top view of transmission mechanism of rotary mechanism in the example provided in the invention.

DETAILED DESCRIPTION OF THE EMBODIMENTS

[0047] Referring to the attached drawings, in particular figures 1-4, the winding machine provided in the invention comprises an upright column, a winding machine base 200, a rotary mechanism 201 and an adjustable membrane frame 204. The rotary mechanism is used for carrying the membrane-wrapped articles.

[0048] The upright column of the winding machine in the invention includes upright column housing main body, and the bottom of which is hinged with the winding machine base 200 by means of a first connecting piece 100. The upright column housing main body is connected to form a column shape by means of the first upright column cover plate 1-11 and the second upright column cover plate 1-12. The winding machine upright column is provided with upright column bottom inner side connecting piece 1-2, which has an upright column outline shaping surface 1-20. The upright column outline shaping surface is a rectangle or rectangle with corner arcuate transition or with bevel; accordingly, the upright column bottom inner side connecting piece 1-2 also has four upright column outline shaping surfaces 1-20 corresponding to rectangles.

[0049] The top of winding machine upright column is provided with top fixed connecting piece 1-3, which is connected to the upright column housing main body; the winding machine upright

column is also provided with the hoisting apparatus supporting frame 1-4, and the low end of which is connected to the bottom inner side connecting piece 1-2. The attached figure mark 1-22 is the connection part of bottom inner side connecting piece corresponding to the hoisting apparatus supporting frame 1-4. The upper end of the hoisting apparatus supporting frame 1-4 is connected to the top mounting rack 1-5 of the hoisting apparatus, and the lower mounting rack 1-51 of hoisting apparatus is connected to the bottom inner side connecting piece 1-2. The attached figure mark 1-21 is the connection part of bottom inner side connecting piece 1-2 corresponding to the lower mounting rack 1-51. All of above components are connected by using bolts or screws. A groove opening for ascending and descending movement is reserved on the upright column housing main body between the first upright column cover plate 1-11 and the second upright column cover plate 1-12.

[0050] The upright column housing main body, upright column bottom inner side connecting piece 1-2, top fixed connecting piece 1-3, hoisting apparatus supporting frame 1-4, top mounting rack 1-5, lower mounting rack 1-51 and hoisting apparatus constitute the assembly of the upright column during transport, which is hinged with the winding machine base 200 by the first connecting piece 100. The hoisting apparatus includes the drive chain 202 and its sprocket, drive motor 203 and its reduction mechanism, etc..

[0051] The upright column cover plates 1-11, 1-12 are processed to a concave-convex structure by rolled reinforcement. By this way, a very thin sheet can guarantee the required rigidity. The upright column is not easily deformed and it is convenient to mount and transport. In addition, the 3-D sense of the upright column is enhanced, with a nice appearance. After rolled reinforcement, the surface of upright column cover plates 1-11, 1-12 form the straight rib 111, which can be the protruding one of outer surface of the upright column cover plate recessed into the inner surface or the protruding one of inner surface of the upright column cover plate recessed into the outer surface, making the upright column cover plate having a concavo-convex structure, or both of them. The rolled reinforcement treatment includes a variety of changes of patterns, which involve various shapes of ribs. The upright column cover plate can be drilled, grooved or cut notches according to needs, to reserve the positions for labeling, control panel and other purposes.

[0052] The upright column cover plates 1-11, 1-12 are bent in the width direction. The upright column cover plate has three faces after bent, corresponding to three facades of the rectangle of upright column. The first facade part 301 of the upright column corresponding to the first upright column cover plate 1-11 and the second upright column cover plate 1-12 is connected by said bolts or screws; a groove opening for ascending and descending movement is reserved between the first upright column cover plate 1-11 and the second upright column cover plate 1-12 on the third facade 303 opposite to the first facade. The upright column is also provided with a lower connection piece 1-9, and the lower connection piece is provided with the connection parts 1-91, 1-92 at both sides of groove opening corresponding to the first and second upright column cover plates at the bottom of the upright column and the connection part 1-93 corresponding to the winding machine base, which are used for connecting the part of the first and second upright column cover plates 1-11, 1-12 at both sides of the groove

opening and winding machine base 200 with bolts or screws when erection and installation of upright column. The erection and installation is generally carried out during commissioning in the manufacturing factory or during the final installation in the production site.

[0053] The end of the first facade corresponding to the first upright column cover plate 1-11 and the second upright column cover plate 1-12 is also folded inside the upright column 1-40, and spliced at the folding and connected by bolts or screws.

[0054] The top fixed connecting piece 1-13 of the upright column in the invention may also have a downward folding 1-30, which is used to fix the column cross-sectional profile, and the upright column housing main body is connected to the folding 1-30.

[0055] The top fixed connecting piece 1-3 of the upright column may form a part of the top cover of the upright column, and the top mounting rack 1-5 of hoisting apparatus forms another part of the top cover of the upright column, which can protect the internal parts of the upright column, and at the same time, facilitate the manufacturing of top fixed connecting piece 1-3 and the top mounting rack 1-5 according to needs.

[0056] The present invention also provides a bottom outside connecting piece 1-6. At the bottom of the upright column facade adjacent to the first connecting piece corresponding to the bottom outside connecting piece 1-6, the connection parts (1-61, 1-62) corresponding to the winding machine base 200 and upright column body are provided, which are used to connect the winding machine base 200 and upright column body, bottom inner side connecting piece 1-2 by bolts or screws when erection and installation of upright column.

[0057] The present invention is also provided with a hoisting apparatus guide rail 1-7. The hoisting apparatus guide rail 1-7, hoisting apparatus supporting frame 1-4 and upright column housing main body are connected by bolts. The hoisting apparatus guide rail 1-7 is located inside the hoisting apparatus supporting frame 1-4 and fastened by bolts and nuts. The bolt 1-70 as shown in FIG.4 can be employed. It has the middle level 1-71, which can pass through the bolt hole 401 of cover plates (1-11, 1-12) to match the nuts to fasten the hoisting apparatus guide rail 1-7 and the hoisting apparatus supporting frame 1-4, so that the upright column cover plates (1-11, 1-12) is not fastened by the nut head 1-72 too tightly.

[0058] In the present invention, opposite to the groove opening for ascending and descending movement, the upright column is provided with a baffle board 1-8, and the bottom of which is connected with bottom inner side connecting piece 1-2 by bolts or screws. The upper portion is plugged with the mounting rack at the top of the hoisting apparatus. The attached figure mark 1-80 is its slot or long hole. A gap 402 is reserved between the both sides of the baffle board and the upright column housing main body for the ascending and descending of parts. By this way, it can not only protect the parts inside the upright column, but also facilitate the disassembly and assembly of baffle board, to maintain the inside part of upright column.

[0059] Referring to the attached figures and in particular figures 5-7, the winding machine in

the invention includes a transition piece 2-4 located outside of winding machine upright column 400 and a connecting piece 2-2 located inside the upright column; the connecting piece 2-2 is connected to the drive chain 202 of the hoisting apparatus, the transition piece 2-4 is connected to the connecting piece 2-2, and the membrane frame 204 is detachably connected to the transition piece 2-4.

[0060] The membrane frame 204 is hung on the transition piece 2-4. The transition piece has two connection parts 2-40 for hanging the upper and lower membrane frames, and the membrane frames have the corresponding hooks 2-41.

[0061] The transition piece 2-4 and the membrane frame 204 are also provided with the connection parts (2-42, 2-43) connected by screws or bolts. The upright column is provided with guide rails 1-7 for ascending and descending movement. A guide part is provided at the connecting piece 2-2 to match with the guide rail 1-7.

[0062] The side of the connecting piece 2-2 is provided with a mounting groove 2-21 facing outwards, and the mounting groove is provided with sliding block 2-3 as the guide part, which can be adjusted front and back in the depth direction of the groove.

[0063] For the adjustment way of sliding block 2-3, the Example employs a very simple, practical structure. The bottom of the mounting groove 2-21 is connected with the adjusting screw 2-5, which holds out against the back of the sliding block 2-3, to adjust the sliding block 2-3 front and back.

[0064] The clearance fit is between the sliding block 2-3 and the left and right walls 2-22 of the mounting groove 2-21, to adjust the adaptive control of sliding block 2-3 left and right according to specific circumstances.

[0065] The mounting groove 2-3 is also provided with the limiting parts (2-61, 2-62) of the upper and lower position of the sliding block, which is located between the upper limiting part and the lower limiting part (2-61, 2-62). The clearance fit is between the sliding block and the upper limiting part 2-61, to adjust the adaptive control of sliding block 2-3 up and down.

[0066] Referring to the attached figures, in particular figures 8,9, the winding machine base in the present invention has two beams- the first beam 3-1 and the second beam 3-2. The first beam 3-1 and the second beam 3-2 are located on both sides of the winding machine upright column 400 transversely, and the first beam 3-1 located at the side of the upright column of lifting membrane frame 204 is shorter which forms a notch 3-5 corresponding to the lifting membrane frame 204, and the lower end of the lifting membrane frame 204 can be descended to the notch 3-5 during working.

[0067] The end of the upright column set with the winding machine base is provided with a fork stretching port 3-6 at two beams. During the implementation, the fork stretching port 3-6 can be formed directly by beams, that is, the end of the beam mounted the winding machine

base is in a flat, peripherally closed shape with the fork stretching port 3-61 in the middle.

[0068] The beam uses the groove-shape steel 3-71 as the main body, and the groove opening is downwards. Steel plate 3-72 is welded at the groove opening, and at the front end of the winding machine base, a fork stretching port 3-62 is formed.

[0069] The winding machine base has a connection structure 3-8 between two beams, to make them a whole. The second beam 3-2 is extended to the side of the base of the upright column 3-30 of the winding machine base, and the upright column base 3-30, the second beam 3-2 and the connection structure at the front of the upright column base are welded.

Referring to the figures, in particular figures 10 and 11, the mode of execution in the present invention also provides a welding structure of the winding machine base. The welding adopts the jack positioning, which facilitates the positioning of the bar and simplifies the welding process, and reinforces the welding structure, improving the welding quality.

[0070] The winding machine base is equipped with beam 3-1, beam 3-2 and bar 4-2. The beam 3-1, beam 3-2 and bar 4-2 are provided with a jack 4-11 at the welding place, which is used to position the connecting location of the beam 3-1, beam 3-2 and bar 4-2. The beam 3-1, beam 3-2 are welded with the bar 4-2 and the bar 4-2 has an insertion site 4-21 matching with the jack 4-11.

[0071] The insertion site 4-21 on the bar matching with the jack is the protruding part at the front of the bar.

[0072] The cross section of the bar 4-2 is in a groove shape and the protruding part is protruding at the end of the groove bottom 4-20.

[0073] One or more said jacks are provided at the welding points between the beam 3-1, beam 3-2 and each bar 4-2.

[0074] As shown in the figures, the winding machine base is provided with two beams at the left and right, which are the first beam 3-1 and the second beam 3-2, and on both sides of each beam is welded with bars, respectively. The bars welded at two beams at the left and right are symmetric relative to the center line between two beams.

[0075] Referring to the figures, in particular figures 12 and 13, the mode of execution of the present invention also provides a support structure of the winding machine rotary mechanism. The structure is simple and the cost is low.

[0076] The present invention includes a roller 5-2 that supports the rotary mechanism 201. The base 5-4 of the roller shaft 5-3 is in an upright groove shape. The roller shaft 5-3 is arranged at the top of the groove-shape base 5-4. When the groove-shape structure is arranged upright, its bottom part plays a role of connection for two upright groove walls in the entire height range of the base, to prevent them from deformation, so that the whole support

structure is firm and the rotary mechanism is supported in a stable and balanced manner. The upright placement is as shown in Figure 13, the groove opening 5-43 is facing the side and the ends of the groove is the upper and lower ends instead of the left and right ends.

[0077] The groove-shape base 5-4 is made by grooved steel or made by bending of steel plate.

[0078] The top of groove wall 5-41 made by grooved steel is provided with a groove 5-40, and the roller shaft 5-3 is propped in the groove 5-40. The attached figure mark 5-42 is a part of the groove bottom of the groove-shape base 5-4.

[0079] The roller shaft 5-3 is non-rotatable shaft, for example, the square shaft fitting with the base 5-4.

[0080] The base 5-4 is mounted on the fixing member on the side of beam welded to the beam 3-1 and the beam 3-2 of the winding machine base, for example, the fixing member 5-6 on bar 4-2 between the beam 3-1 and the beam 3-2.

[0081] The support structure further comprises a multiple of support members 5-8 distributed circumferentially on the concentric chain wheel 5-7 that drives the rotary mechanism to rotate.

[0082] Referring to the attached figures, in particular figure 14, in the mode of execution in the present invention, a transmission mechanism of rotary mechanism is provided, which has tensioning effect for the chain with stable tension state, moreover, the tension of the chain can be automatically adjusted according to the actual situations, so that the rotary mechanism can smoothly rotate, enhancing the membrane-wrapping effect.

[0083] The transmission mechanism 201 comprises a coaxial drive sprocket 5-7 and a drive chain 6-2 of the rotary mechanism. The transmission mechanism has a fixed tensioning wheel 6-3 and movable tensioning wheel 6-4 relative to the chain and the movable tensioning wheel is acting on the chain 6-2 by the tension of spring 6-5. The rotary mechanism 201 can be the turntable that connects to the shaft of drive sprocket.

[0084] The movable tension wheel 6-4 is mounted on the pivotable mounting member 6-6, which is connected to the spring 6-5, and the spring 6-5 is mounted on the fixing member such as the winding machine base. The mounting member 6-6 is a flat object.

[0085] Further, the transmission mechanism may also be provided with position limiting mechanism of the movable tensioning wheel. The mounting member 6-6 is provided with an arcuate groove 6-7 that plays a limiting role. The arcuate groove 6-7 uses the pivot point 6-60 of the mounting member 6-6 as the center of circle. The transmission mechanism is also provided with a fixed arresting pin 6-8, which can be mounted on the winding machine base, and the arresting pin 6-8 is inserted in the arcuate groove 6-7.

[0086] The fixed tensioning wheel 6-3 and movable tensioning wheel 6-4 are located outside of two sides of the chain loop.

[0087] The positions of said tensioning wheel 6-3 and movable tensioning wheel 6-4 are basically symmetrical relative to the axis of said drive sprocket 5-7 and driving sprocket 6-9 of the chain, that is, it is preferred that the midpoint of movable tensioning wheel is symmetrical to the fixed tensioning wheel 6-3. The driving sprocket 6-9 rotates driven by a motor.

REFERENCES CITED IN THE DESCRIPTION

This list of references cited by the applicant is for the reader's convenience only. It does not form part of the European patent document. Even though great care has been taken in compiling the references, errors or omissions cannot be excluded and the EPO disclaims all liability in this regard.

Patent documents cited in the description

- [CN101503118 \[0003\] \[0003\]](#)
- [CN201660134 \[0004\]](#)
- [WO2009087600A \[0005\]](#)
- [US2012175170A \[0006\]](#)

Patentkrav

1. Viklemaskine omfattende:

- 5 - en opretstående søjle (400),
 - en viklemaskinefod (200),
 - en rotationsmekanisme (201), og
 - en membranramme (204), der kan løftes,
- hvori:
- 10 - den opretstående søjle omfatter en søjlehusovedkrop (3-71), og hvis bund er forbundet med viklemaskinefoden med en første søjledækplade (1-11), hvilken viklemaskinefod er forbundet ved hjælp af en første søjledækplade og en anden søjledækplade (1-12) til dannelse af en søjleform, hvor den opretstående søjle er forsynet med et søjlebundsundersideforbindelsesstykke (1-2) med en søjlekonturformet overflade (1-20),
 - 15 - den søjlekonturformede overflade er forbundet med søjlehusovedkroppen,
 - et fast forbindelsesstykke ved toppen (1-3) er også forbundet med søjlehusovedkroppen,
 - den opretstående søjle er også indvendigt forsynet med en hejseapparatbæreramme (1-4), hvor den nedre ende af hejseapparatbærerammen er forbundet med
 - 20 bundundersideforbindelsesstykket, hvor den øvre ende af hejseapparatbærerammen er forbundet med en topmonteringsophæng (1-5) af et hejseapparat,
 - et nedre monteringsophæng (1-51) af hejseapparatet er forbundet med bundundersideforbindelsesstykket,
 - alle komponenterne er forbundet ved anvendelse af bolte eller skruer, og
 - 25 - en rilleåbning for opstigende og nedstigende bevægelse er reserveret på søjlehusovedkroppen mellem den første søjledækplade og den anden søjledækplade, hvori søjlehusovedkroppen, søjlebundundersideforbindelsesstykket, øverste faste forbindelsesstykke, hejseapparatbæreramme, topmonteringsophæng, nedre monteringsophæng og hejseapparat udgør samlingen af den opretstående søjle under
 - 30 transport, som er hængslet med viklemaskinefoden under brug af et første forbindelsesstykke (100), og at den opretstående søjle er forbundet med membranrammen med et overgangsstykke (2-4) for at tillade løft af membranrammen for at sikre, at membranrammen ikke beskadiges, når samlingen er arrangeret fladt med viklemaskinefoden, **kendetegnet ved, at** overgangsstykket (2-4) er placeret udenfor viklemaskinens opretstående søjle, og der findes et forbindelsesstykke
 - 35 (2-2) placeret inde i den opretstående søjle; forbindelsesstykket er forbundet med hejseapparatets drivkæde, overgangsstykket er forbundet med forbindelsesstykket, og membranrammen er aftageligt forbundet med overgangsstykket.

2. Viklemaskine ifølge krav 1, hvori søjledækpladen er bukket i bredderetningen; søjletværsnitsprofilet er et rektangel eller rektangel med hjørnebueovergang eller med hjørnerejfnig; søjledækpladen har tre flader efter bukning, svarende til tre flader af en opretstående søjles rektangel; den første fladedel af den opretstående søjle svarende til den første søjledækplade og den anden søjledækplade er forbundet med boltene eller skrueerne; en rilleåbning til opstigende og nedstigende bevægelse er reserveret mellem den første søjledækplade og den anden søjledækplade på den tredje facade modsat den første facade; den opretstående søjle er også forsynet med et nedre forbindelsesstykke (1-9), og det nedre forbindelsesstykke er tilvejebragt med forbindelsesstykket på begge sider af rilleåbningen svarende til de første og andre søjledækplader ved bunden af den opretstående søjle og forbindelsesdelen svarende til viklemaskinefoden, som anvendes til at forbinde delen af de første og andre søjledækplader ved begge sider af rilleåbningen og viklemaskinefoden med bolte eller skrueer ved opsætning og installation af opretstående søjle.

3. Viklemaskine ifølge krav 2, hvori enden af den første flade svarende til de første og andre søjledækplader også er foldet inde i den opretstående søjle og splejset ved foldningen og forbundet med bolte eller skrueer.

4. Viklemaskine ifølge krav 1, hvori den opretstående søjle er overfor rilleåbningen til opstigende og nedstigende bevægelse, hvor den opretstående søjle er forsynet med en afbøjningsplade, og hvis bund er forbundet med bundundersideforbindelsesstykket med bolte eller skrueer, og det øvre parti er tilproppet med monteringsophænget ved toppen af hejseapparatet, et mellemrum (402) er reserveret mellem begge sider af afbøjningspladen og søjlehus hovedkroppen for opstigningen og nedstigningen af dele.

5. Viklemaskine ifølge krav 1, hvori den opretstående søjle er forsynet med føringskinner til opstigende og nedstigende bevægelse, hvor hejseapparatføringskinnen (1-7), hejseapparatbærrammen og søjlehus hovedkroppen er forbundet med bolte, hejseapparatføringskinnen er placeret inde i hejseapparatets bærramme og fastgjort med bolte og møtrikker; viklemaskinen har et forbindelsesstykke, og forbindelsesstykket er forbundet med hejseapparatets drivkæde i den opretstående søjle, og føringsdelen er tilvejebragt ved forbindelsesstykket for at passe til føringskinnen; forbindelsesstykket er forsynet med en monteringsrille (2-21), der vender udad, og monteringsrillen er forsynet med en skydeklods (2.3) som føringsdel, som kan justeres frem og tilbage i rillens dybderetning.

- 5 6. Viklemaskine ifølge krav 5, hvori spillerummet er mellem skydeklodsen og venstre og højre vægge af monteringsrillen; monteringsrillen er også forsynet med begrænsende dele (2-61, 2-62) i skydeklodsens øvre og nedre position, og som er placeret mellem den øvre begrænsningsdel og den nedre begrænsningsdel; og en spillerumspasning findes mellem skydeklodsen og den øvre begrænsningsdel.
- 10 7. Viklemaskine ifølge krav 5, hvori viklemaskinefoden er forsynet med to bjælker (3-1, 3-2), som er placeret på begge sider af viklemaskinesøjlen på tværs, og den første bjælke placeret ved siden af den opretstående søjle af løftemembranramme er kortere, hvilket danner et indhak svarende til løftemembranrammen, og den nedre ende af løftemembranrammen kan føres ned til indhakkets, hvor enden af den opretstående søjle sat med viklemaskinefoden er forsynet med en gaffelstrækkeport ved to bjælker.
- 15 8. Viklemaskine ifølge krav 1, hvori viklemaskinefoden er udstyret med bjælker og stænger, hvor bjælken og stangen er forsynet med en donkraft (4-11) ved svejsestedet, som anvendes til at placere bjælkens og stangens forbindelsessted, bjælken er svejst til stangen og stangen har indføringsstedet passende med donkraften.
- 20 9. Viklemaskine ifølge krav 1, hvori viklemaskinefoden er forsynet med viklemaskinerotationsmekanismens bærekonstruktion, og bærekonstruktionen omfatter en rulle (5-2), der understøtter rotationsmekanismen, og rulleakslens basis er i lodret rilleform, og rulleakslen er arrangeret på toppen af den rilleformede basis.

DRAWINGS

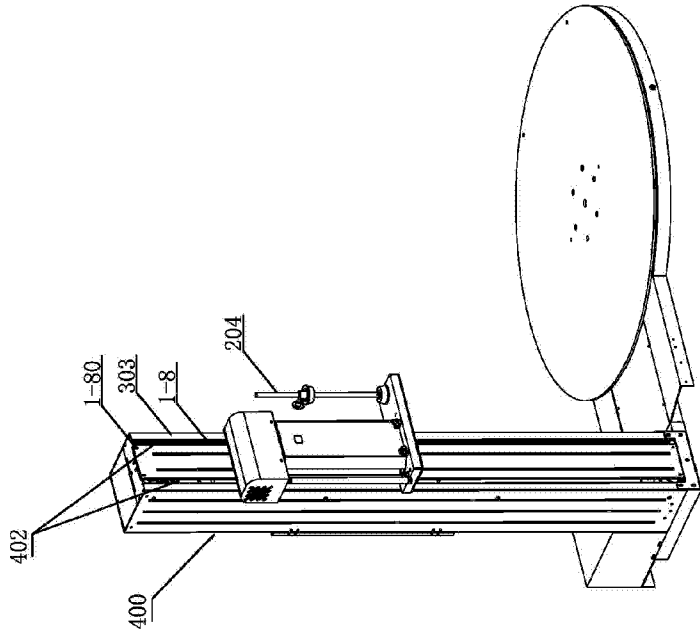

Fig. 2

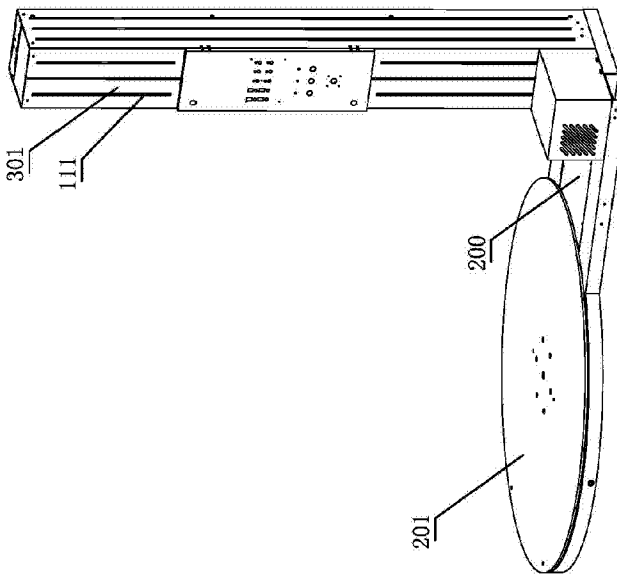

Fig. 1

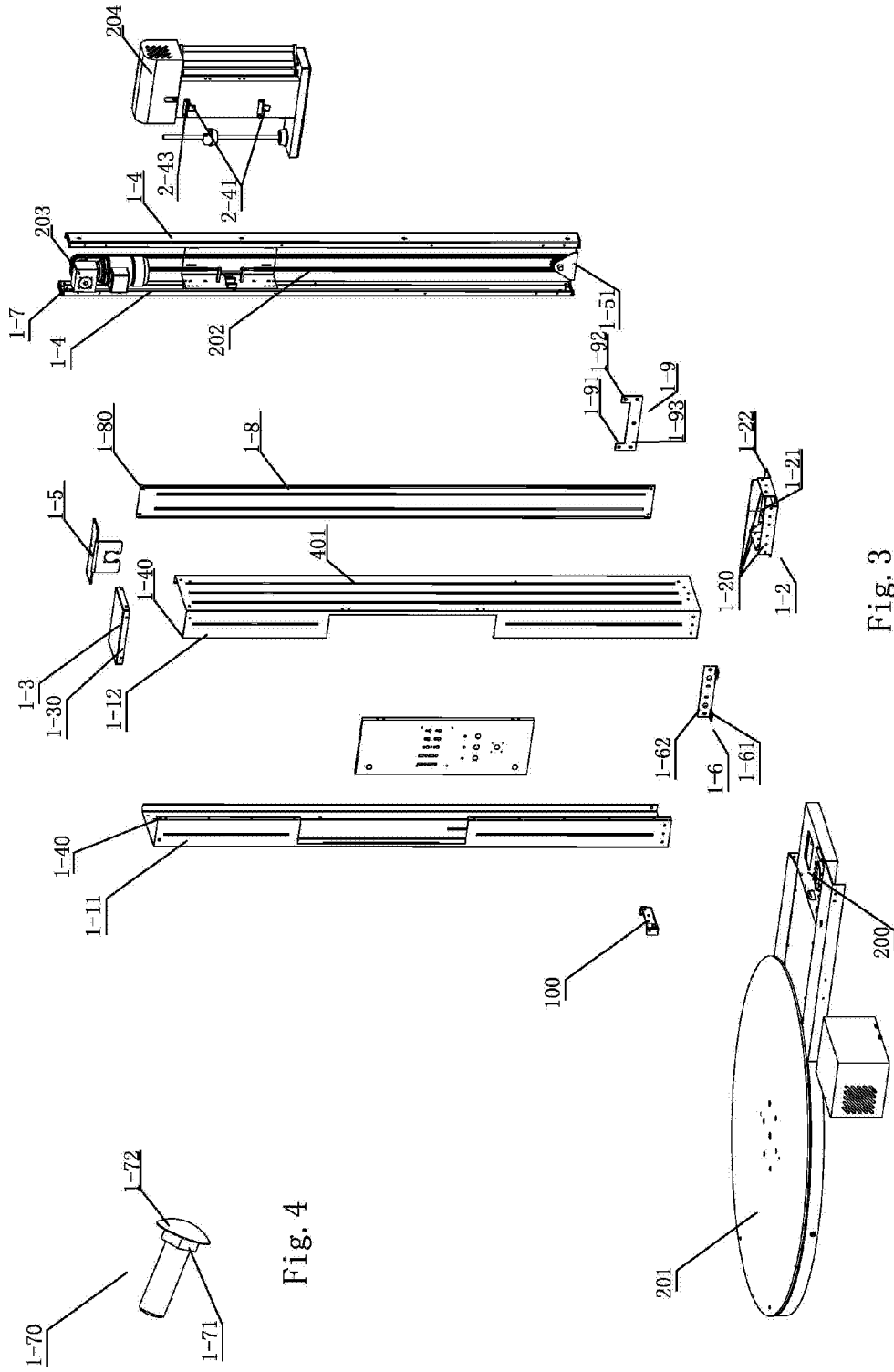

Fig. 3

Fig. 4

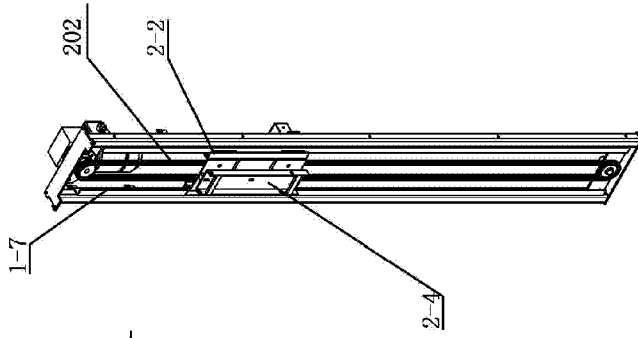

Fig. 5

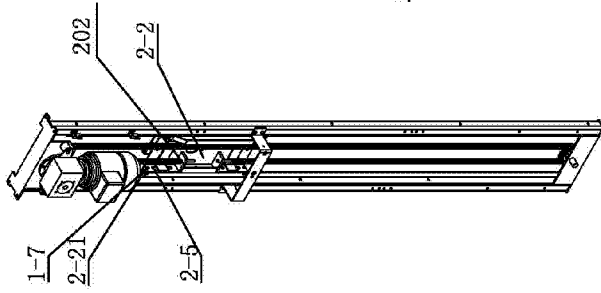

Fig. 6

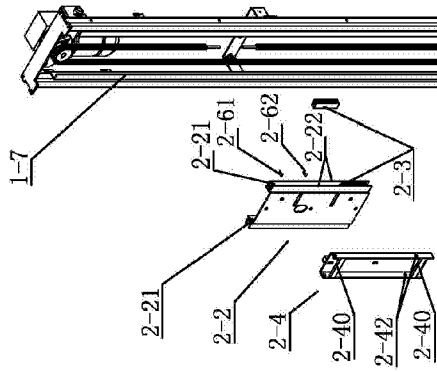

Fig. 7

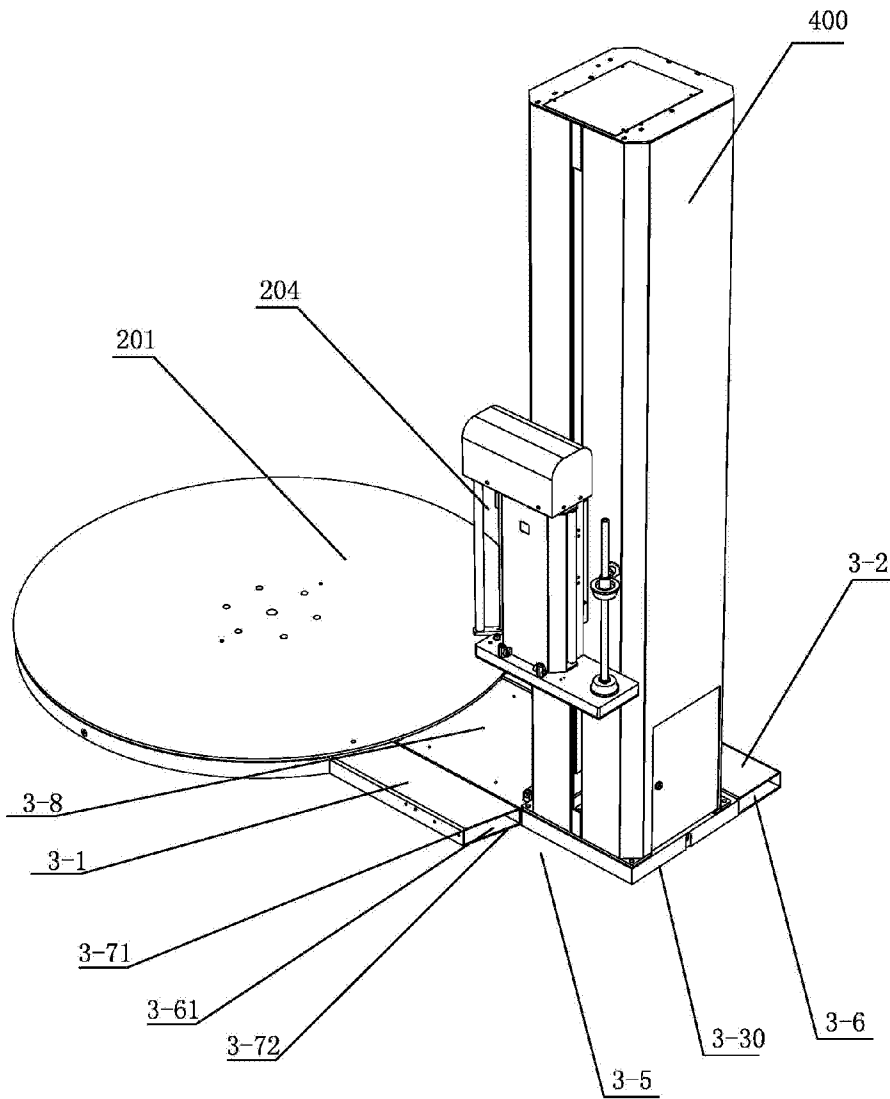

Fig. 8

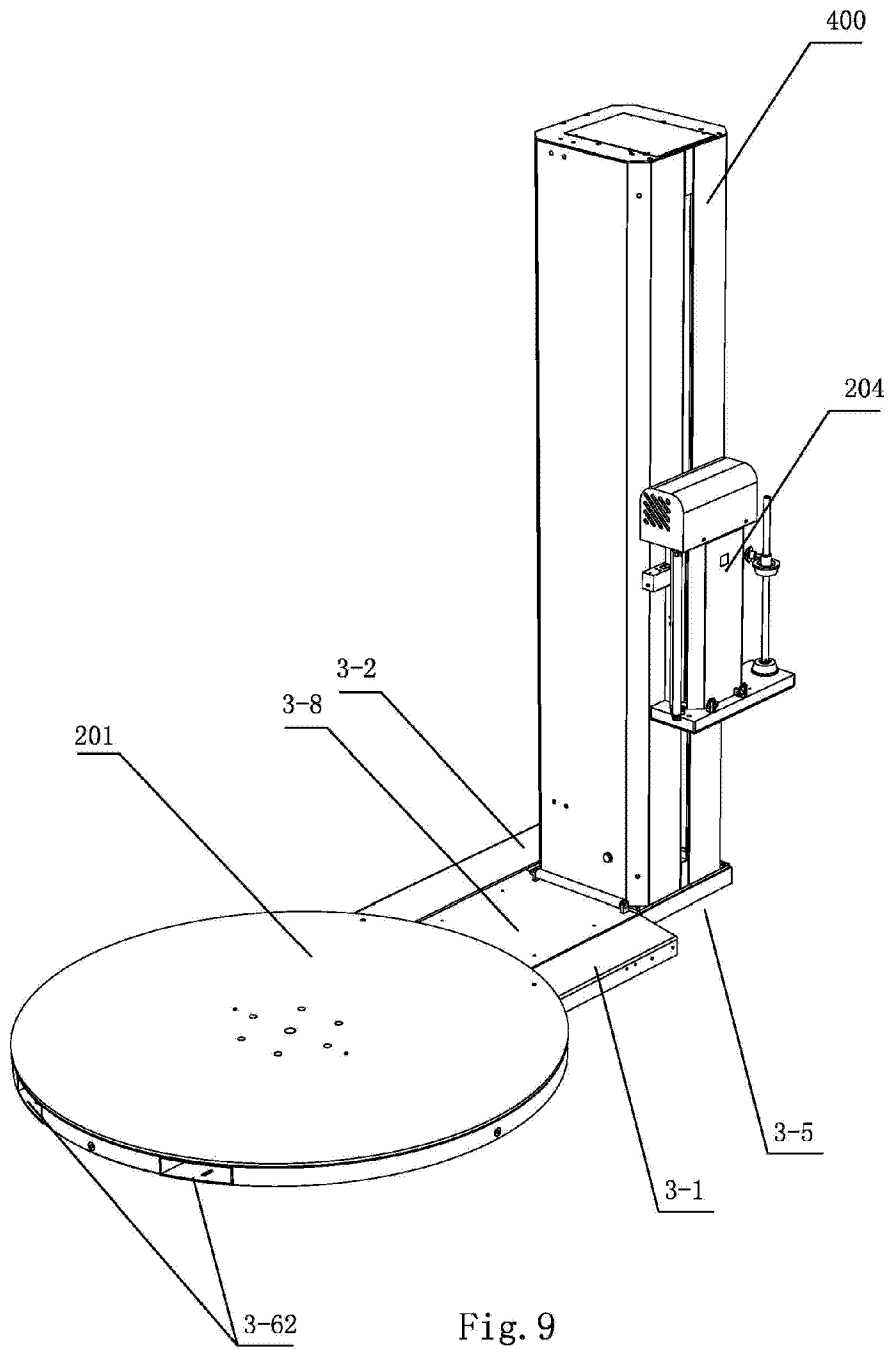

Fig. 9

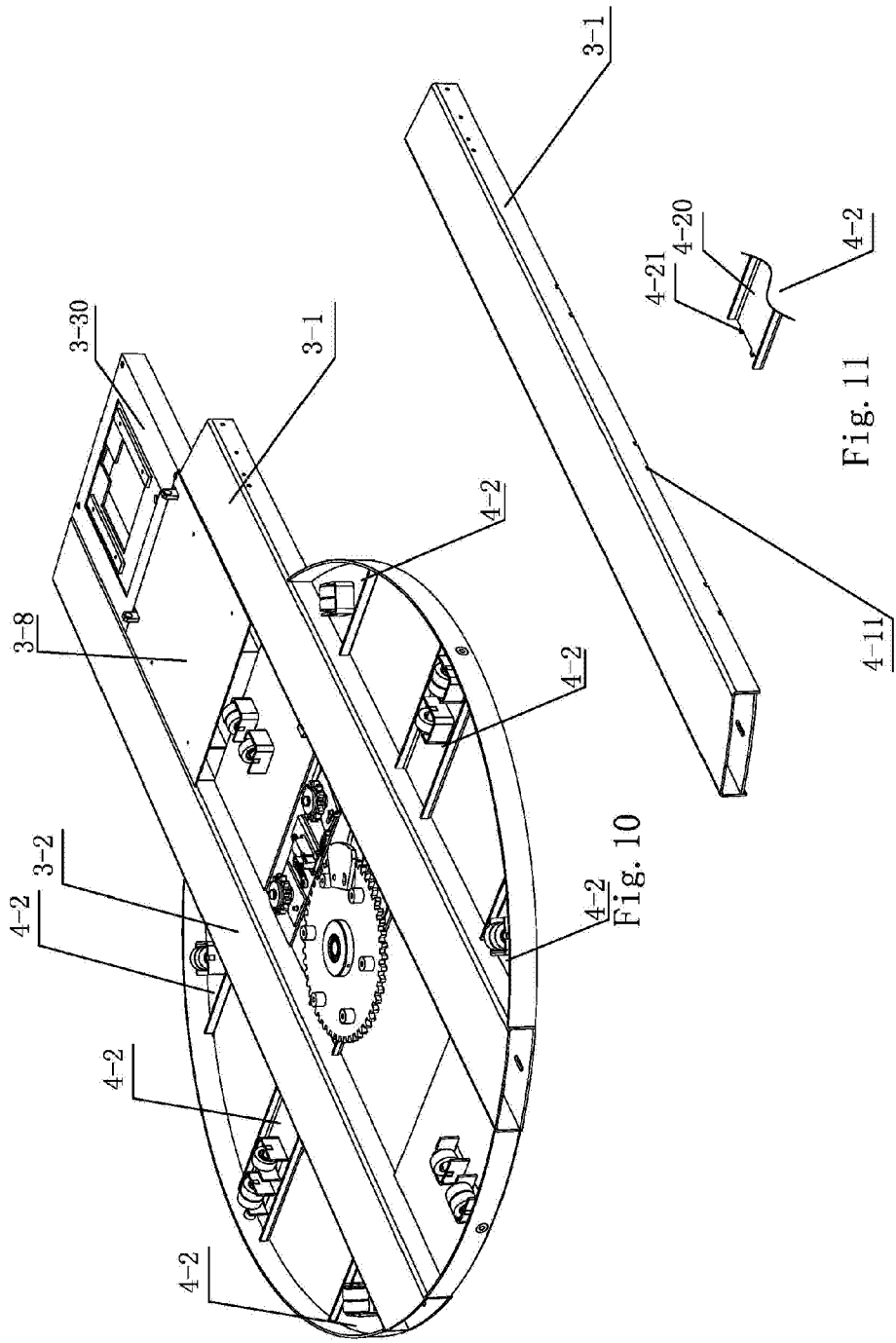

Fig. 11

Fig. 10

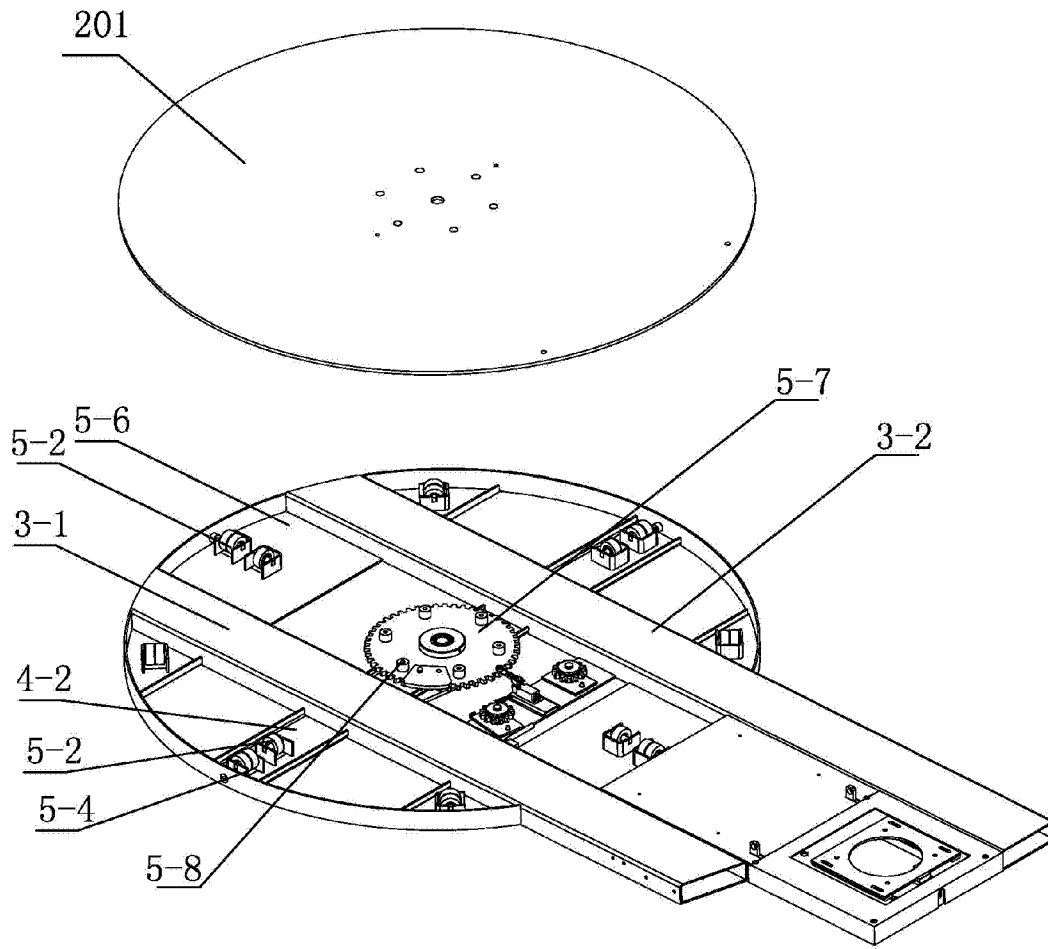

Fig. 12

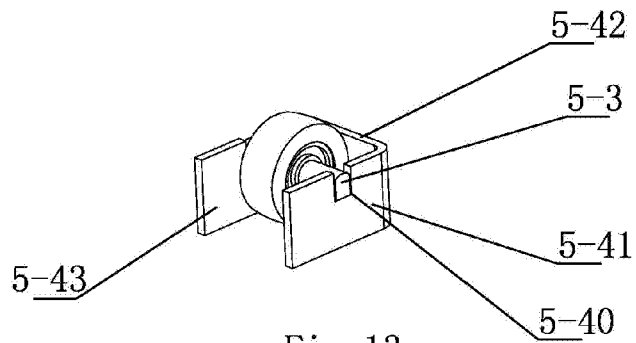

Fig. 13

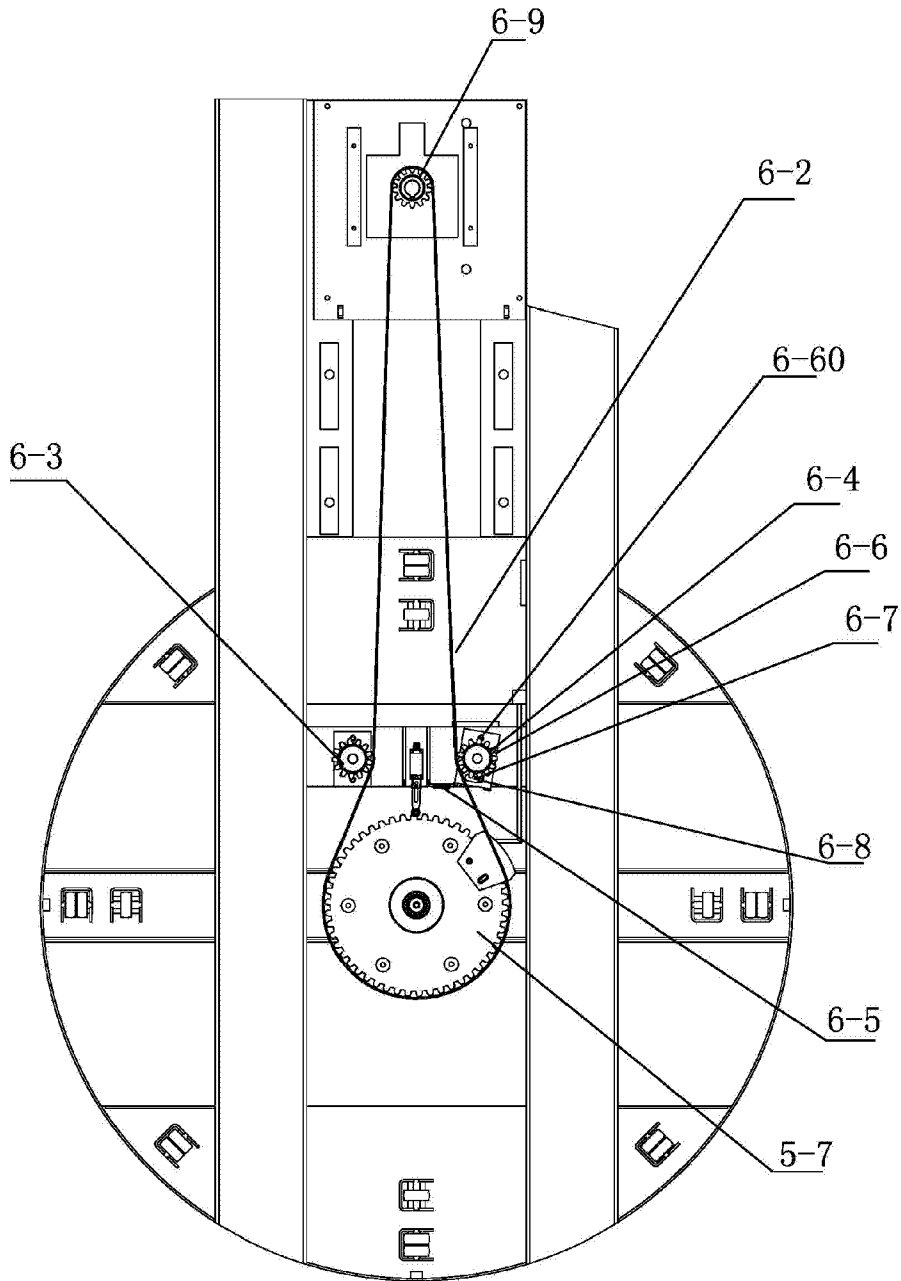

Fig. 14