



- (51) International Patent Classification:
H04N 5/33 (2006.01) *G02B 3/00* (2006.01)
- (21) International Application Number:
PCT/US2016/014373
- (22) International Filing Date:
21 January 2016 (21.01.2016)
- (25) Filing Language: English
- (26) Publication Language: English
- (30) Priority Data:
62/106,708 22 January 2015 (22.01.2015) US
14/965,863 10 December 2015 (10.12.2015) US
14/965,875 10 December 2015 (10.12.2015) US
- (71) Applicant: **INVIS TECHNOLOGIES CORPORATION**. [US/US]; 2880 Zanker Road, Suite 203, San Jose, California 95134 (US).
- (72) Inventors: **KINTZ, Gregory J.**; 2880 Zanker Road, Suite 203, San Jose, California 95134 (US). **BATEY, John**; 2880 Zanker Road, Suite 203, San Jose, California 95134 (US). **GANAPATHI, Srinivasan K.**; 2880 Zanker Road,

Suite 203, San Jose, California 95134 (US). **STEPHANO, Philip J.**; 2880 Zanker Road, Suite 203, San Jose, California 95134 (US). **PETERSEN, Kurt E.**; 2880 Zanker Road, Suite 203, San Jose, California 95134 (US).

(74) Agents: **MUELLER, Heather** et al.; 12707 High Bluff Drive, Suite 200, San Diego, California 92130 (US).

(81) Designated States (unless otherwise indicated, for every kind of national protection available): AE, AG, AL, AM, AO, AT, AU, AZ, BA, BB, BG, BH, BN, BR, BW, BY, BZ, CA, CH, CL, CN, CO, CR, CU, CZ, DE, DK, DM, DO, DZ, EC, EE, EG, ES, FI, GB, GD, GE, GH, GM, GT, HN, HR, HU, ID, IL, IN, IR, IS, JP, KE, KG, KN, KP, KR, KZ, LA, LC, LK, LR, LS, LU, LY, MA, MD, ME, MG, MK, MN, MW, MX, MY, MZ, NA, NG, NI, NO, NZ, OM, PA, PE, PG, PH, PL, PT, QA, RO, RS, RU, RW, SA, SC, SD, SE, SG, SK, SL, SM, ST, SV, SY, TH, TJ, TM, TN, TR, TT, TZ, UA, UG, US, UZ, VC, VN, ZA, ZM, ZW.

(84) Designated States (unless otherwise indicated, for every kind of regional protection available): ARIPO (BW, GH, GM, KE, LR, LS, MW, MZ, NA, RW, SD, SL, ST, SZ, TZ, UG, ZM, ZW), Eurasian (AM, AZ, BY, KG, KZ, RU,

[Continued on next page]

(54) Title: GRADIENT INDEX LENS FOR INFRARED IMAGING

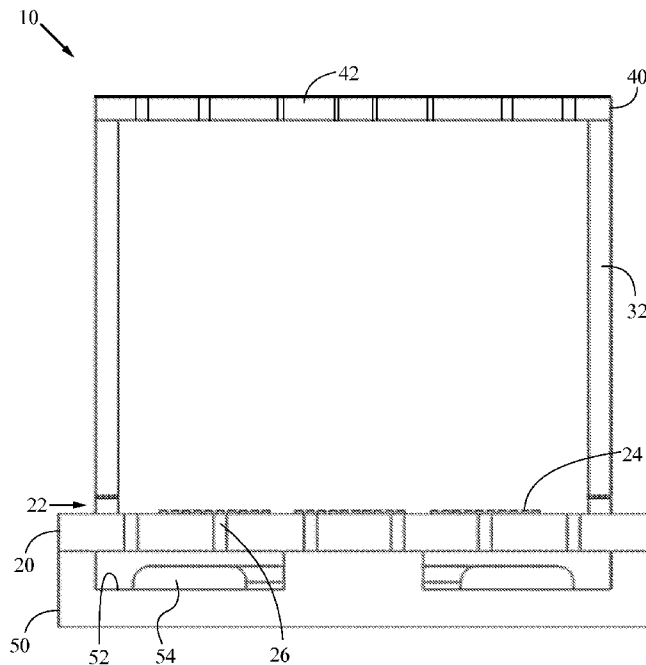

FIG. 1

(57) Abstract: A gradient-index lens for directing incident electromagnetic radiation comprises at least one substrate having a plurality of micro-features (e.g., trenches or holes) that may be arranged in a pattern of varied size and/or spacing. Each of the micro-features has at least one dimension that is less than a wavelength of the electromagnetic radiation. The spacing between adjacent micro-features is less than the wavelength of the electromagnetic radiation, and the size and spacing of the micro-features are sufficient to produce an effective refractive index profile of the lens that is graded. A thermal imaging device incorporating a gradient-index lens is also provided.

TJ, TM), European (AL, AT, BE, BG, CH, CY, CZ, DE, DK, EE, ES, FI, FR, GB, GR, HR, HU, IE, IS, IT, LT, LU, LV, MC, MK, MT, NL, NO, PL, PT, RO, RS, SE, SI, SK, SM, TR), OAPI (BF, BJ, CF, CG, CI, CM, GA, GN, GQ, GW, KM, ML, MR, NE, SN, TD, TG).

Published:

— *without international search report and to be republished upon receipt of that report (Rule 48.2(g))*

Patent Application of
**Gregory J. Kintz, John Batey, Srinivasan K. Ganapathi, Philip J. Stephanou and Kurt
E. Petersen**
for
Gradient Index Lens for Infrared Imaging

CROSS REFERENCE TO RELATED APPLICATIONS

[0001] This application claims priority to U.S. Patent Application No. 14/965,863 filed December 10, 2015, U.S. Patent Application No. 14/965,875 filed December 10, 2015, and U.S. Provisional Patent Application No. 62/106,708 filed on January 22, 2015, all of which are hereby incorporated by reference in their entirety.

BACKGROUND

[0002] Certain existing thermal imaging solutions for night vision are based on uncooled micro-bolometer arrays that are sensitive to long wavelength infrared (LWIR) radiation in the wavelength range of about 8 to 15 μm . The infrared (IR) camera typically includes a camera core comprising a Focal Plane Array (FPA), a lens system and an enclosure. The FPA typically comprises multiple elements – the underlying Read-Out Integrated Circuit (ROIC), the thermistor or micro-bolometer pixel array which is built on top of the ROIC, usually on the same silicon wafer and integrated with the ROIC, and a “packaged window” or lid which is substantially transparent to incoming IR radiation from a source and bonded on top of the FPA with a hermetic vacuum seal. A single lens or a system of lenses is mounted on top of the FPA.

[0003] In certain conventional lenses, an effective index of refraction may be varied across the area of the lens to focus incident electromagnetic radiation. In an example, a convex lens may have a thickness that decreases as a function of radial position from its center. In another example, a conventional gradient index (GRIN) lens may have an index of refraction that decreases as a function of radial position from its center.

[0004] Typically, the optical lens system can be complex and involve multiple lens elements. In the case of infrared (IR) imaging optics, the lens material is usually made through diamond point turning of germanium, which can be an expensive process. Traditionally, the approach chosen to enable vacuum has been to use a crystalline germanium lid, and bond it to the FPA

package. In order to minimize stresses due to differential coefficients of expansion, the FPA wafer is first singulated into die and mounted on a ceramic package. The germanium lid is then bonded to the ceramic package under vacuum. In spite of its high cost, germanium is selected as a lid material because of its low attenuation of infrared light in the relevant range of wavelengths.

[0005] Consequently, many micro-bolometer devices currently available for thermal imaging are bulky, expensive, and largely restricted to special use cases such as military or high-end automotive applications. Many conventional night vision cameras cost several thousands of dollars apiece, making their integration into mid- and low- range priced applications prohibitive. There is a need for a night vision thermal imaging camera core that enables a small form factor and low cost while maintaining adequate performance.

SUMMARY

[0006] According to an aspect, a gradient-index lens for directing incident electromagnetic radiation comprises at least one substrate having a plurality of curved trenches formed therein. Each of the curved trenches has at least one dimension that is less than a wavelength of the electromagnetic radiation. Each of the trenches preferably has a ratio of length to width that is greater than or equal to about 3:1. The spacing between adjacent trenches is less than the wavelength of the electromagnetic radiation, and the size and spacing of the curved trenches are sufficient to produce an effective refractive index profile of the lens that is graded.

[0007] According to another aspect, a gradient-index lens for directing electromagnetic radiation comprises at least one substrate having a plurality of trenches or holes formed therein. Each of the trenches or holes has at least one dimension that is less than a wavelength of the electromagnetic radiation, and the spacing between adjacent trenches or holes is less than the wavelength. The size and spacing of the trenches or holes are sufficient to produce an effective refractive index profile of the lens that is graded, and the f-number divided by the diameter of the lens is less than 1.5

[0008] According to another aspect, a thermal imaging device comprises at least one pixel disposed on a focal plane substrate. The thermal imaging device also comprises at least one gradient-index lens. The lens comprises at least one lens substrate having a plurality of micro-features formed therein. The size and spacing of the micro-features are sufficient to

produce an effective refractive index profile of the lens that is graded. The lens is positioned to direct incident electromagnetic radiation to the pixel, and the lens substrate is arranged with the focal plane substrate to enclose the pixel in a vacuum in a space between the lens substrate and the focal plane substrate. At least one readout circuit is electrically connected to the pixel.

BRIEF DESCRIPTION OF THE DRAWINGS

[0009] Fig. 1 is a schematic, cross-sectional view of a thermal imaging device according to some embodiments of the invention.

[0010] Fig. 2 is a top plan view of a gradient-index lens having concentric circular trenches, according to some embodiments of the invention.

[0011] Fig. 3 is a top plan view of a gradient-index lens having sub-wavelength discontinuities in concentric circular trenches, according to another embodiment of the invention.

[0012] Fig. 4 is a schematic, plan view of a gradient-index lens having L-shaped trenches according to another embodiment of the invention.

[0013] Fig. 5 is a schematic diagram of a gradient-index lens having trenches that are arranged in a pattern of spokes, according to another embodiment of the invention.

[0014] Fig. 6 is a schematic diagram of a gradient-index lens having trenches that are arranged in a pattern of crosses according to another embodiment of the invention.

[0015] Fig. 7 shows a plot of the effective index of refraction on the left vertical axis and the corresponding micro-feature size on the right vertical axis, according to some embodiments of the invention.

[0016] Fig. 8 is a chart of a relation between etch depth and trench width, according to some embodiments of the invention.

[0017] Fig. 9 is a schematic, side view of a GRIN lens directing electromagnetic radiation to focused spots on a focal plane, according to some embodiments of the invention.

[0018] Fig. 10 is a graph showing an example of an effective index profile resulting from a combination of aspheric index coefficients, according to some embodiments of the invention.

[0019] Fig. 11 is a schematic, side view of two GRIN lenses arranged to direct electromagnetic radiation to focused spots on a focal plane, according to some embodiments of the invention.

[0020] Fig. 12 is another graph showing an example of an effective index profile resulting from a combination of index coefficients, according to some embodiments of the invention.

[0021] Fig. 13 is another graph showing an example of an effective index profile resulting from a combination of index coefficients, according to some embodiments of the invention.

[0022] Fig. 14 is another graph showing an example of an effective index profile resulting from a combination of index coefficients, according to some embodiments of the invention.

[0023] Fig. 15 is a schematic, side view of three GRIN lenses arranged to direct electromagnetic radiation to focused spots on a focal plane, according to some embodiments of the invention.

[0024] Fig. 16 is another graph showing an example of an effective index profile resulting from a combination of index coefficients, according to some embodiments of the invention.

[0025] Fig. 17 is another graph showing an example of an effective index profile resulting from a combination of index coefficients, according to some embodiments of the invention.

[0026] Fig. 18 is another graph showing an example of an effective index profile resulting from a combination of index coefficients, according to some embodiments of the invention.

[0027] Fig. 19 is another graph showing an example of an effective index profile resulting from a combination of index coefficients, according to some embodiments of the invention.

[0028] Fig. 20 is another graph showing an example of an effective index profile resulting from a combination of index coefficients, according to some embodiments of the invention.

[0029] Fig. 21 is a schematic, cross-sectional view of another thermal imaging device according to some embodiments of the invention.

[0030] Fig. 22 shows an example of a half-tone mask pattern on a surface of a substrate, according to some embodiments of the invention.

[0031] Fig. 23 is a top plan view of an array of GRIN lenses formed in a lens substrate according to some embodiments of the invention.

[0032] Fig. 24 is a top plan view of another array of GRIN lenses formed in a lens substrate according to some embodiments of the invention.

[0033] Fig. 25 shows a schematic block diagram of another thermal imaging device according to some embodiments of the invention.

[0034] Fig. 26 is a block diagram illustrating the imaging of a scene and reconstruction of the original image according to some embodiments of the invention.

[0035] Fig. 27 shows a schematic block diagram of another thermal imaging device according to some embodiments of the invention.

[0036] Fig. 28 is a block diagram illustrating an ideal deep reactive ion etching (DRIE) process.

[0037] Fig. 29 is a block diagram illustrating a typical side wall angle in a DRIE process.

[0038] Fig. 30 is a block diagram illustrating the stacking of etched substrates to form a GRIN lens according to some embodiments of the invention.

[0039] Fig. 31 is a block diagram illustrating the stacking of etched substrates to form a GRIN lens according to another embodiment of the invention.

[0040] FIG. 32 is a block diagram illustrating a GRIN lens comprising a blind etched substrate with a thin lid, according to some embodiments of the invention.

[0041] Fig. 33 is a block diagram illustrating a GRIN lens comprising a through-etched substrate with two thin lids according to some embodiments of the invention.

[0042] Fig. 34 is a block diagram illustrating a GRIN lens comprising two blind etched substrates bonded to form enclosed trenches or holes according to some embodiments of the invention.

[0043] Fig. 35 shows a schematic, side view of a GRIN lens with diffractive optical elements formed in a lens substrate according to some embodiments of the invention.

[0044] Fig. 36 shows a schematic, side view of a GRIN lens with micro-features formed in two sides of a substrate according to another embodiment of the invention.

[0045] Figs. 37A-F are schematic block diagrams illustrating fabrication steps for producing a lens with micro-features formed in two sides of a substrate, according to some embodiments of the invention.

[0046] Fig. 38 is a schematic side view of another GRIN lens comprising two substrates attached to form enclosed trenches or holes, according to some embodiments of the invention.

DETAILED DESCRIPTION OF PREFERRED EMBODIMENTS

[0047] Fig. 1 shows a thermal imaging device **10** that includes a focal plane array (FPA) **22** preferably formed on a wafer or substrate **20**. The FPA **22** comprises an array of pixels **24** (e.g., a micro-bolometer or other device that converts incident electromagnetic radiation to a corresponding electrical signal). In an example of a focal plane array, the pixels are arranged in rows and columns (e.g., 40x60 pixels to 1,024x768 pixels) with a pitch in the range of about 7 μm to 50 μm . In an example of a pixel, each pixel comprises a thermistor that changes its electrical resistance in response to incident electromagnetic radiation (e.g., in the infrared wavelengths).

[0048] The device **10** also includes at least one gradient-index (GRIN) lens **42** formed in a lens substrate **40**. The lens **42** is arranged to direct incident electromagnetic radiation (e.g., infrared rays) to focused spots on the pixels **24**. The lens **42** has an effective refractive index profile that is graded (e.g., gradual variations in the refractive index of the lens). Such variations in the refractive index can be used to produce lenses with flat surfaces, or lenses that do not have the aberrations typical of traditional spherical lenses. Gradient-index lenses may have a refraction gradient that is spherical, axial, or radial (e.g., the effective refractive index varies as a function of radial position from the center of the lens). A spacer or standoff structure **32** may optionally be used to position the lens **42** at a desired separation from the FPA **22** (e.g., the focal length of the lens). In some examples, the separation of the lens **42** from the pixels **24** provides an optical path length in the range of 2 to 14 mm. The standoff structure **32** may be patterned, for example, from silicon (e.g., by DRIE of a SOI wafer), a metal, ceramic, glass or polymer.

[0049] The lens substrate **40** preferably encloses the pixels **24** in a vacuum in a space between the lens substrate **40** and the FPA substrate **20**. The term vacuum is intended to mean a space in which the pressure is lower than atmospheric pressure. In some embodiments, the standoff structure **32** forms the vertical walls around the periphery of the enclosed space containing the pixels **24** between the lens substrate **40** and the FPA substrate **20**. A hermetic seal may be formed, for example, using a fusion bonding process to bond the FPA substrate **20** and the lens substrate **40** to opposite sides of the standoff structure **32**. In other embodiments, the lens substrate **40** is attached directly to the FPA substrate **20**, e.g., using a fusion bonding process.

[0050] The lens substrate **40** preferably has a thickness in the range of 250 to 2000 μm to impart bending stiffness and to resist excessive deflection. In some examples, a substrate is a single crystal silicon wafer with a diameter in the range of 100 mm to 450 mm. To aid maintenance of a vacuum, a cavity substrate **50** is optionally attached to the FPA substrate **20**. In some embodiments, the cavity substrate **50** has one or more cavities **52** fluidically connected to the vacuum space between the lens substrate **40** and the FPA substrate **20** by means of vias **26** in the FPA substrate **20**.

[0051] A readout circuit is electrically connected to the pixels **24**. In some embodiments, a Read-Out Integrated Circuit (ROIC) underlies the FPA **22**. As an example, the readout circuit may comprise an analog-to-digital converter, a signal conditioning element, a power conditioning element, a memory element and other elements to translate electromagnetic radiation incident on a pixel into a corresponding electrical signal. In some examples, a ROIC may be implemented using a CMOS process. Preferably, the FPA **22** is built on top of the ROIC on the same silicon wafer or substrate **20** and integrated with the ROIC.

[0052] Once the FPA/ROIC substrate **20** has been fabricated, the FPA **22** is preferably packaged such that it is maintained in a vacuum to minimize heat transfer between the pixels **24** and the ambient environment through atmospheric convection. Maintaining a desired level of vacuum (e.g., a pressure in the range of 0.1 to 100 mTorr) may optionally be aided by putting getter material **54** in the cavities **52**. A getter is a material that, when enclosed within a vacuum, helps maintain the vacuum by removing (e.g., using a chemical reaction or by adsorption) gas particles that come in contact with it. The getter material may comprise, for example, an alloy containing zirconium and one or more of vanadium, cobalt, iron, aluminum, or titanium.

[0053] A GRIN lens is an implementation of an optical element that may be used to focus incident electromagnetic radiation. The macro-scale behavior of a metamaterial may be understood in terms of the effective medium theory (EMT). Within the context of planar refractive optical elements, EMT states that the effective refractive index n_{eff} of a heterogeneous element comprising a two-dimensional array of sub-elements having a characteristic dimension L and intrinsic refractive indices n_1 and n_2 is given approximately by a weighted average of n_1 and n_2 for incident wavelengths λ satisfying $\lambda \gg L$ (e.g., $\lambda > 10L$). The exact effective refractive index is typically determined numerically through the use of electromagnetic simulation software (e.g., OptiFDTD commercially available from Optiwave), including the effects of polarization and incident plane angle.

[0054] In the planar GRIN lens 42, a pattern of micro-features may be varied spatially across the area of the lens to tailor the resulting refractive properties of the overall element. The micro-features (e.g., trenches, curved trenches, holes, posts or pillars) can vary in their size, spacing, and placement. Each of the micro-features preferably has at least one dimension (e.g., width or diameter) that is less than the wavelength of the electromagnetic radiation incident on the lens 42. The term “less than the wavelength of the electromagnetic radiation” represents cases in which a size of a dimension (e.g., the width of a micro-feature or the spacing between adjacent micro-features) should be smaller than a wavelength of the electromagnetic radiation incident on the GRIN lens to ensure effective functioning of the lens in directing (e.g., focusing) the electromagnetic radiation. The wavelengths at which each GRIN lens is operated may be different, and therefore the size of the dimension that is less than the wavelength of the electromagnetic radiation may also be different in different applications of the lens.

[0055] The electromagnetic radiation typically has a wavelength in the range of 1 to 15 micrometers (μm) for many applications of the lens (e.g., for directing infrared rays in the near, mid and far-infrared wavelength ranges). In some LWIR embodiments, the electromagnetic radiation has a wavelength in the range of 8 to 15 μm . Each of the micro-features preferably has at least one dimension that is in the range of 150 nm to 15 μm and that is less than the wavelength of the electromagnetic radiation for the intended operation of the lens. Similarly, the spacing between adjacent micro-features is preferably in the range of 150 nm to 15 μm and less than the wavelength of the electromagnetic radiation for the desired application of the lens. In some embodiments, the shortest dimension of each of the micro-

features (e.g., its width or diameter) and the spacing between adjacent micro-features are both less than 15 μm , more typically less than 8 μm , and in some embodiments less than 2 μm or 1 μm . To create optimized lenses, materials with low absorption in the wavelength range of interest are advantageous to mitigate transmission losses through the GRIN lens. Materials with suitable properties for infrared applications include, for example, germanium (Ge), silicon (Si), zinc sulfide (ZnS), zinc selenide (ZnSe), and chalcogenide glass. In some cases Si has the further benefit of enabling lower cost.

[0056] In general, the pattern of the micro-features formed in the planar GRIN lens 42 may be varied as an arbitrary function of position across the lens element to impart a corresponding profile for the effective index of refraction. The in-plane pattern of the micro-features in a planar GRIN lens is analogous to the out-of-plane surface profile of a traditional lens in terms of providing a mechanism for tailoring the refractive properties of the resulting lens. In some implementations of a planar GRIN lens, it may be advantageous to have air or vacuum as one of the refractive sub-elements. For the purposes of the present disclosure, both air and vacuum substantially have an index of refraction $n = 1$, and may thus be used interchangeably to describe a “trench” or “hole” type of micro-feature.

[0057] In some patterns for implementing the planar GRIN lens 42, the spacing of the trenches or holes may be substantially the same and the width or diameter of the trenches or holes may be changed across the lens element. In other examples, both the size and the spacing of the trenches or holes may be varied. In essence, the ratio of matrix dielectric material to air or vacuum determines the effective refractive index of a given unit area. In an example of a planar GRIN lens, a substrate represents a high refractive index, and a trench or hole represents a low refractive index. The trenches or holes may be formed using a variety of manufacturing techniques. In the case of a planar GRIN lens using air or vacuum holes in a silicon wafer matrix, it may be advantageous to form the holes or trenches using traditional micro-electromechanical systems (MEMS) processes such as photolithographic pattern reproduction, thin film deposition, wet etching and deep reactive ion etching (DRIE).

[0058] In other examples, the effective density of a matrix material (e.g., a substrate) is reduced in a prescribed manner across its area to form the GRIN lens 42. In such cases, the effective refractive index of the medium may again be a weighted average of the matrix material and of air or vacuum, but with the weighting determined by the effective density of the matrix material. As an example, a silicon substrate may be modified using a porous

silicon process (e.g., a process that substantially changes the density of silicon) such as electrochemical etching. The porous process forms micro-features that are pores in the matrix material to selectively reduce the effective density of the matrix material, and hence refractive index, in a manner that supports focusing or steering incident electromagnetic radiation.

[0059] Fig. 2 shows a first example of a GRIN lens 41 having trenches that are curved (e.g., deviating from straightness in a smooth, continuous fashion). In this example, then lens 41 has a pattern of concentric circular trenches 66. The trenches 66 are spaced apart with a spacing that is less than the wavelength of the electromagnetic radiation. For example, the spacing is in the range of 150 nm to 15 μ m and is sub-wavelength. At the center of the lens 41, the trenches 66 are narrower than toward the edge of the lens where the width of the trenches 66 increases. At the edge of the lens 41 where more of the substrate material is removed, the width of the trenches 66 can increase and the spacing of the trenches 66 can decrease so that both the width and spacing are less than the wavelength of the electromagnetic radiation (e.g., the width and spacing are both in the range of 150 nm to 15 μ m and are both sub-wavelength).

[0060] Fig. 3 shows another example of a GRIN lens 43 having curved trenches (e.g., trenches that deviate from straightness in a smooth, continuous fashion). In this example, the curved trenches 67 are shaped like arcs. The arc-shaped trenches 67 are arranged in a pattern of concentric circles or rings having discontinuities that are less than the wavelength of the electromagnetic radiation. The discontinuities of the concentric circles or rings are portions of the lens 43 where the substrate material remains between the trenches 67 that are formed in the lens substrate. The discontinuities typically have dimensions in the range of 150 nm to 15 μ m and are sub-wavelength in size. The discontinuities provide material for mechanical support, especially in the case where the trenches 67 are etched all the way through the lens substrate (e.g., a silicon wafer) and there is no base support material. Many patterns of curved trenches are possible, including trenches whose cross-sectional area is shaped like an arc, spiral, circle or ring. One advantage to curved trenches is that diffraction effects may be minimized.

[0061] Fig. 4 shows another example of a GRIN lens 21 having L-shaped trenches 69 formed in a substrate. Fig. 5 shows a GRIN lens 23 having trenches 19 that are arranged in a pattern of spokes. Radial spokes are shown in this example, but other patterns are possible including

spirals to minimize diffraction effects. Fig. 6 shows a GRIN lens 15 having trenches 17 that are arranged in a pattern of crosses.

[0062] In general, the trenches may have cross sections that are shaped like arcs, spirals, circles, rings, rectangles, hexagons, L-shaped, spokes, crosses, etc. The cross section of a trench is the intersection of the trench in three-dimensional space with a plane that is substantially perpendicular to a line defining the depth of the trench. Each of the trenches preferably has a ratio of length to width that is greater than or equal to 3:1. The ratio of trench length to trench width is typically in the range of 3:1 to 100,000:1. The “length” of a trench means the longest dimension of the cross-sectional area in the plane, and “width” means the shortest dimension of the cross-sectional area. For example, if the trench has a cross-section that is shaped like a rectangle in a plane that is perpendicular to the depth line, then the length of the trench is the longest dimension of the rectangle, and the width of the trench is the shortest dimension of the rectangle. In some examples, the ratio of the length of the cross-sectional area to the width of the cross-sectional area is greater than or equal to about 50:1, and in other examples the ratio is greater than or equal to 100:1.

[0063] The trench width preferably keeps the spacing between the trenches well below the wavelength of the electromagnetic radiation, or unwanted losses can occur. When forming a trench in a substrate, the rate of etching varies inversely with trench width, and thus a very narrow trench will not be as deep as a wider trench. The narrower trenches may have a slightly greater density to compensate for the lack of depth.

[0064] Fig. 7 shows a plot of the effective index of refraction on the left vertical axis and the optimal micro-feature size on the right vertical axis. As the effective index of refraction approaches the index of the bulk material (i.e., very little material removed from the lens substrate), the optimal micro-feature size (e.g., width of the trench and spacing between adjacent trenches) should decrease. Table 1 shows examples of how to maintain micro-feature sizes well below the wavelength of light in silicon (Bulk index = 3.42).

Effective Index	% Material Removed	Trench Width (μm)	Trench Spacing (μm)
2.21	50%	1	1.0
2.936	20%	0.4	2.0
3.178	10%	0.2	2.0
3.299	5%	0.1	2.0

Table 1

[0065] Fig. 8 shows the impact of decreasing trench width on etch depth; the narrower the trench the shallower the trench. To create a good GRIN lens, the effective index of refraction should be maintained over the entire depth of the GRIN lens. However, given the fundamental relationship between etch rate and trench width, the trench width may be modulated (increased) in some embodiments to account for the shallower depth. The relationship between etch depth and the modulated trench width is given approximately by the following equation (1):

$$T_f = T_i \cdot (D_w / D_n) \quad (1)$$

where: T_f = Final Narrow Trench Width;

T_i = Initial Narrow Trench Width;

D_w = Wide Trench Depth; and

D_n = Narrow Trench Depth.

[0066] The width of narrow (shallower) trenches may be increased slightly to compensate for the shallower trench depth. Of course, the width of the trenches can be compensated to account for other factors including but not limited to the change in etch rate due to a high density of trenches.

[0067] In some examples, the present invention provides a design and fabrication method for individual and arrays of batch fabricated GRIN lenses that may also serve as part of a wafer-level package (WLP) for a FPA within a camera core. In some examples, a WLP comprises two or more substrates that are bonded together (e.g., using a solder, anodic, or fusion bonding process) to enclose an element requiring isolation from the ambient environment. For example, a lens may be used to focus incident infrared rays onto an imaging sensor such as a micro-bolometer-based FPA. Batch fabricated arrays of GRIN lenses may be used in configurations that simultaneously support schemes for wafer-level optics (WLO) and WLP.

This approach further enables multi-spectral, super-resolution, and/or plenoptic imaging schemes.

[0068] An imaging lens system produces a focused image at the focal plane array, where the focused spot sizes in the image are ideally about the size of a pixel. While a near perfect imaging lens system will produce diffraction limited spot sizes over the entire focal plane array, it is not uncommon for an imaging lens system to be much better at the optical center of the lens system and the performance will fall off towards the edges of the focal plane array. The reduction of the performance off of the optical center of the lens system can be compensated with image processing techniques like sharpening. An imaging lens system has a characteristic Field of View related to the specific application of the imaging lens system. Imaging lens system with a narrow Field of View, typically less than 25 degrees are used in applications including imaging of circuit components on printed circuit boards and electrical wiring. Narrow field of view imaging lens systems are also used in surveillance cameras to provide detailed images of remote scenes. Imaging systems with a medium Field of View, typically between 25 to 60 degrees, are used in a range of thermal imaging applications including surveillance and security. Imaging systems with a wide Field of View, greater than 60 degrees, are used for automotive and security applications.

[0069] The production of a lens system that produces a quality image at the focal plane array may have several characteristics. The lens system may have one or more GRIN lens elements with an aspheric profile. The aspheric profile may differ greatly from a quadratic index profile. The lens system should have an aperture sized appropriately for the pixels within the focal plane array. The lens system should have a Field of View consistent with the target application. The lens system may have anti-reflection coatings on the lens surfaces to minimize reflections from the lens surfaces. The anti-reflection coating can include thin film dielectric coating and sub-wavelength structured coatings.

[0070] Fig. 9 shows an example of an imaging lens system comprising a single etched-silicon GRIN lens **71**. The lens system targets a narrow Field of View of 14.5 degrees. The diameter of the lens **71** is chosen to be 5 mm to match the size of a focal plane array **22** with 160 x 120 pixel micro-bolometer with 17 μm pixels, and a 3.4 mm diagonal. The lens **71** is created by etching micro-features (e.g., trenches or holes having a width or diameter of 1 μm), 145 μm deep on a 350 μm thick silicon substrate. The coefficients of the index profile for the lens system are in Table 2. The index profile of the lens is an aspheric profile.

This surface has the same shape as the Standard surface, with media whose index of refraction is described by

$$n^2 = n_0 + n_{r2}r^2 + n_{r4}r^4 + n_{r6}r^6 + n_{r8}r^8 + n_{r10}r^{10} + n_{r12}r^{12}$$

where $r^2 = x^2 + y^2$ (2).

n0	1.1560E+01
nr2	-1.8769E+00
nr4	1.6137E-01
nr6	-2.8632E-02
nr8	3.9672E-03
nr10	-2.0614E-04

Table 2

[0071] Fig. 10 shows the resulting effective refractive index profile from this combination of aspheric index coefficients. The index profile is at the index of bulk silicon at the center of the lens (Bulk index = 3.42), thus no trenches or holes are etched into the center of the lens. The index drops to 1.8 at the edge of the lens. To produce an effective refractive index of 1.8, 66% of the material is etched away at the edges of the lens.

[0072] Referring again to Fig. 9, the imaging lens 71 produces a set of focused spots at the focal plane array 22. The strehl ratio of the different field points varies from 0.965, nearly a perfectly focused spot, at the center to 0.454 at the most extreme field point. The minimum spot size is 25 μm, close to the target pixel size of 17 μm. The lens has a diameter of 5 mm. The focal length of the lens is 13.4 mm, and the f-number (f/#) for the lens is 2.68. The f-number divided by the diameter (d) of the lens (f#/d) is a parameter related to the strength of the lens. In this example, the f-number divided by the diameter of the lens (f#/d) = 2.68/5 = 0.536.

[0073] If we divide the f/# by the diameter of the lens, then we get a parameter that is nominally independent of lens radius. A stronger lens produces a smaller parameter. The f-number divided by the diameter of the lens (f#/d) is preferably less than or equal to 1.5 (e.g., in the range of 0.05 to 1.5). Table 3 shows examples for lenses having diameters in the range of 1 to 5 mm, focal lengths in the range of 1.44 to 37.4 mm, and effective refractive indexes in the range from 1.5 (at the edges of the lens) to 3.4 (at the center of the lens). For smaller lenses, the f/# generally improves (f/# = focal length/diameter).

Diameter	Focal length	f/#	f#/d	Depth of trenches or holes in lens
5 mm	37.4 mm	7.48	1.496	50 um depth
4 mm	23.9 mm	5.975	1.494	50 um depth
3 mm	13.4 mm	4.47	1.489	50 um depth
2 mm	5.95 mm	2.975	1.488	50 um depth
1.5 mm	3.33 mm	2.22	1.480	50 um depth
1 mm	1.44 mm	1.44	1.440	50 um depth
5 mm	13.39 mm	2.678	0.536	145 um depth

Table 3

[0074] Fig. 11 shows an example of an imaging lens system comprising two GRIN lenses 72, 73 etched in silicon. The lens system targets a medium Field of View of 35 degrees. The diameter of the lens is chosen to be 3.5 mm to match the size of a 160 x 120 pixel microbolometer with 17 μm pixels, and a 3.4 mm diagonal. The lens system is created by etching micro-features (e.g., trenches or holes having a width or diameter of 1 μm), 150 μm deep on a 350 μm thick silicon substrate on the first etched GRIN lens 72 and 150 μm deep on both sides of a second 500 μm thick substrate to form the second lens 73.

[0075] The lens system uses three GRIN lens surfaces to achieve the steering functions to produce a good image quality over the entire focal plane array 22. The index of refraction profiles of the three GRIN lens surfaces are shown in Fig. 12, Fig. 13, and Fig. 14, respectively. The coefficients of the GRIN lens surfaces are shown in Table 4.

	First GRIN	Second GRIN	Third GRIN
n0	1.1560E+01	8.0000E+00	1.1560E+01
nr2	-2.1875E+00	2.0000E+00	-5.8005E+00
nr4	1.9556E-01	-6.2124E-02	1.1448E+00
nr6	-5.8514E-02	-2.0945E-01	-2.7864E-02
nr8	1.9406E-02	2.9043E-02	-1.8085E-02
nr10	-2.4066E-03	-9.9689E-04	2.0056E-03

Table 4

[0076] The strehl ratio of the different field points varies from 0.965, nearly a perfectly focused spot, at the center to 0.71 at the most extreme field point. The minimum spot size is

15 μm , close to the target pixel size of 17 μm . The lens system has a 3.5 mm diameter and a 5.5 mm focal length with a resulting working f-number of 1.62. In this example, the f-number divided by the diameter of the lens system ($f\#\!/d$) = $1.62/3.5 = 0.463$.

[0077] Fig. 15 shows an example of an imaging lens system comprising three GRIN lenses 74, 75 and 76. The lens system targets a wide Field of View of 80 degrees. The diameter of the first lens 74 is chosen to be 2.0 mm and the interior lenses 75, 76 are 3.8 mm and 4.1 mm in diameter, respectively, to match the size of a 160 x 120 pixel micro-bolometer with 17 μm pixels, and a 3.4 mm diagonal. Micro-features are etched in silicon (e.g., trenches or holes having a width or diameter of 1 μm), 150 μm deep on a 350 μm thick silicon wafer for the first lens 74, 150 μm deep on both sides of a second 500 μm thick wafer for the second lens 75, and 150 μm deep on both sides of a third 500 μm thick wafer for the third lens 76.

[0078] The lens system uses five GRIN lens surfaces to achieve the steering functions to produce a good image quality over the entire focal plane array 22. The index of refraction profiles of the five GRIN lens surfaces are shown in Fig. 16, Fig. 17, Fig. 18, Fig. 19 and Fig. 20, respectively. The coefficients of the GRIN lens surfaces are shown in Table 5:

	First GRIN	Second GRIN	Third GRIN	Fourth GRIN	Fifth GRIN
n0	1.1560E+01	1.1560E+01	1.1560E+01	1.1560E+01	1.1560E+01
nr2	-2.6482E+00	-1.2326E+00	-1.8858E+00	-3.1849E+00	-3.6213E+00
nr4	3.6805E-01	4.5315E-02	4.5359E-02	2.9811E-01	4.0120E-01
nr6	-2.7546E-03	-1.8849E-02	-2.3057E-02	9.1686E-04	6.9815E-03
nr8	-7.7755E-03	-1.4555E-03	6.5004E-06	-7.3609E-04	-7.0091E-03
nr10	3.2197E-03	-6.2757E-05	9.0594E-04	1.0071E-04	1.1407E-03

Table 5

[0079] The strehl ratio of the different field points varies from 0.91, nearly a perfectly focused spot at the center, to 0.83 at the most extreme field point. The minimum spot size is 12 μm , below the target pixel size of 17 μm . The lens system has a 2.0 mm aperture and a 2.5 mm focal length with a resulting working F-number of 1.27. In this example, the f-number divided by the diameter of the lens system ($f\#\!/d$) = $1.27/2 = 0.635$.

[0080] In the previous examples, wider field of views typically require more GRIN surfaces to achieve the steering of the electromagnetic radiation to be focused onto the FPA. These specific examples are meant to illustrate the principles of the optical design of various etched

silicon GRIN lens systems, and are not limiting the to the scope. Many other values may be selected for the specific depths, trench or hole sizes, and index coefficients, as well as different combinations of parameters and/or materials. Other examples of imaging lens systems are possible using other lens types in combination with the etched GRIN lenses, including but not limited to refractivity etched silicon lenses, diamond turned infrared lenses, a lens formed from a porous Si process, a diffractive optic, a molded glass lens, or a Fresnel optic.

[0081] Fig. 21 shows a thermal imaging device **12** having multiple standoff structures **32**, **34** and **36** for holding corresponding GRIN lenses **42**, **44** and **46**. Multiple standoff structures are useful in embodiments that utilize multiple lenses. In some embodiments, the first GRIN lens substrate **40** may effectively take the place of a separate lid wafer as part of a WLP. Accordingly, the first standoff structure **32** may be used to form the lateral “walls” of a WLP and to maintain the appropriate separation (along the optical axis) between the pixels **24** on the FPA substrate **20** and the corresponding GRIN lens **42** formed in the first lens substrate **40**. The height of the first standoff structure **32** may be chosen to correspond to a focal length of the lens **42**.

[0082] In some embodiments, the first standoff structure **32** is placed and bonded around the FPA substrate **20**, and the first lens substrate **40** is placed and bonded to the resulting assembly at the first standoff structure **32**. In other embodiments, the first standoff structure **32** may first be placed and bonded around the first lens substrate **40**, and the FPA substrate **20** is subsequently placed and bonded to the resulting assembly at the first standoff structure **32**. The standoffs may be placed using, for example, a pick and place process. The bonds between the FPA substrate **20** and the first standoff structure **32** and between the first standoff structure **32** and the first lens substrate **40** may be formed using, for example, a solder, brazing or fusion bonding process. The standoffs may be formed using a material such as, for example, a metal, ceramic, glass, polymer, or combinations thereof.

[0083] In order to minimize heat transfer between the micro-bolometer pixels **24** and the ambient environment through convection, a FPA may be packaged under a vacuum. Thus, the bonds between the FPA substrate **20** and first standoff structure **32**, the first standoff structure **32** and first lens substrate **40**, and lens **42** should be substantially hermetic. The FPA substrate **20**, standoff structure **32** and lens substrate **40** may be assembled and bonded (as described above) to form hermetic seals in a vacuum environment. Alternatively, the FPA

substrate **20**, standoff structure **32** and lens substrate **40** may be assembled and bonded such that a fluidic “port” remains between the packaged volume and ambient environment. The package assembly is subsequently evacuated in a vacuum environment and the port hermetically sealed.

[0084] Some embodiments may further comprise a second GRIN lens **44** arranged to direct electromagnetic radiation to the first lens **42** and disposed at a prescribed distance from the first GRIN lens substrate **40** using a second standoff structure **34**. The second standoff structure **34** may be substantially aligned with the first standoff structure **32** such that the second lens **44** is substantially aligned with the first lens **42**. The second standoff structure **34** may be placed using, for example, a pick and place process. The bonds may be formed using, for example, a solder or fusion bonding process. The second standoff structure **34** may be formed using a material such as, for example, a metal, ceramic, glass, polymer, or combinations thereof. The volume enclosed between the first lens substrate **40** and a second lens substrate **47** may be open to the ambient environment or hermetically sealed and, in the latter case, either maintained at a vacuum or filled with a gas such as air or dry nitrogen at a pressure substantially greater than vacuum.

[0085] The above concepts are readily scalable to lens systems comprising greater than two lens substrates in the optical path by incorporating a third GRIN lens substrate **46** and a third standoff structure **36**, a fourth GRIN lens substrate and a fourth series of standoffs, and so forth. In some embodiments, the standoff structures may be designed to mitigate the temperature sensitivity of the overall camera core. For example, the material of a standoff may be chosen such that the temperature coefficient of expansion of the resulting standoff offsets the temperature coefficient of index of refraction of a lens.

[0086] To create the aspheric index profiles of the previous examples, several techniques may be employed. In some embodiments, the principles of halftoning are applied to create the varying index profiles. Halftone is a reprographic technique that simulates continuous tone imagery through the use of dots, varying either in size, in shape or in spacing, thus generating a gradient like effect. "Halftone" can also be used to refer specifically to the image that is produced by this process. Fig. 22 show an example of the concept of using a “halftone” process to generate the pattern of trenches or holes in a GRIN lens. The white color represents the unetched silicon and the increasing grey color represents the reduced index of refraction created by the etched silicon. The ideal distribution of the index of

refraction is transformed by the half-toning process into a series of white and black pixels, where the white pixels are locations of unetched silicon and the black pixels are locations of etched silicon. The density of the trenches or holes increases towards the edge of the lens substrate.

[0087] Several mathematical algorithms exist to produce the half-toning process including but not limited to Ordered method, Jarvis method, Stucki method, Floyd-Steinberg method, and Cardinality-Distribution method. An important consideration in the halftoning process is not to produce any ordered areas where the micro-feature sizes approach the wavelength of light to reduce unwanted diffraction and or scattering effects of the incident light. The halftoning methods of Jarvis, Stucki or Floyd-Steinberg generally produce more uniform distributions of features and minimize unwanted diffraction and or scattering effects.

[0088] The half-toning process can be further improved by shifting the locations of the etched micro-features to produce a more uniform distribution. Unlike traditional halftoning processes used in printing, the location of the trenches or holes in the silicon can be finely tuned. A mathematical method can be applied to the distribution of etched trenches or holes to minimize spacing when the wavelength of the incident light is approached. The method includes an effective index calculation over an area of the etched lens. The effective index is integrated over a circle or a Gaussian distribution with a diameter equal to the wavelength of incident light. Ideally this effective index is equal to the desired effective index of the lens design. However, if the effective index of the lens differs from the ideal, the position of the etched trenches or holes can be modified to bring the effective index closer to the desired value. The method can be applied from the center moving out in concentric circles to minimize the difference between the ideal and effective index calculation. The method can be applied iteratively several times to improve the effective index calculation.

[0089] Fig. 23 shows an example of a 2x2 round planar GRIN lens array **80**. In some embodiments, $n \times m$ element arrays or arrays of sub-arrays of planar GRIN lenses may be co-fabricated monolithically on a single-crystal silicon or silicon-on-insulator (SOI) substrate **81** using traditional MEMS batch fabrication processes such as photolithographic pattern reproduction, thin film deposition, wet etching and DRIE. In this example, the array **80** has micro-features **82** that are circular in cross-section.

[0090] Fig. 24 shows an example of a 2x2 rectangular planar GRIN lens array **83** having trenches **87** that are rectangular in cross-section. Each of the trenches **87** preferably has a ratio of cross-sectional length to cross-sectional width that is greater than or equal to 3:1. In some embodiments, a DRIE process may be used to form a pattern of sub-wavelength trenches, holes, pores, posts or pillars in a silicon (Si) substrate such that the resulting element imparts a desired focusing behavior for incident electromagnetic radiation in accordance with the EMT. Each planar GRIN lens in an array may be configured to address a corresponding FPA on a FPA substrate. In some cases, a FPA may comprise an array of FPA sub-arrays. Moreover, in these embodiments, each GRIN lens may comprise an array of GRIN “lenslets” configured to address corresponding FPA sub-arrays.

[0091] In some embodiments, the planar GRIN lens array **83** comprises substantially identical planar GRIN lens unit cells. In other embodiments, an $n \times m$ element planar GRIN lens array comprises different unit cells such as, for example, lenses having different relative apertures (F/#), anti-reflection (AR) coatings, color filters, optical axis orientation, or width or diameter. The differences in optical behavior of lens elements within the planar GRIN lens array are imparted by corresponding differences in the underlying patterns of the etched micro-features. In some embodiments, the micro-features comprise pillars or posts, and in other embodiments the micro-features may comprise a combination of a plurality of trenches or holes and a plurality of pillars or posts.

[0092] Fig. 25 shows a schematic block diagram of incident electromagnetic radiation (e.g., infrared rays) being focused to three distinct focal points by corresponding elements of a 3x1 planar GRIN lens array **84**. The use of a multi-aperture lens system allows variations in the way the individual aperture collects information from a scene, including independent aspheric and diffractive surface design of different lenses within the array **84**, off-axis mounting, diversity in field of view, capture time, digital zoom, and even variations in focal plane. This information enables a processor **60** to perform a wide range of reconstruction analysis with an image reconstruction program **62**, which in turn may provide more information about a scene than could be available from a single aperture system.

[0093] The thermal imaging device **14** can be configured to process scene data from all available pixels on the FPA/ROIC substrate **20** to achieve the highest possible resolution, or from a subset of the pixels to reduce power consumption, depending on the user’s requirements. The use of multiple apertures provides an “oversampling” of the image.

Therefore, even if the image from one of the pixels is defective (e.g., due to mis-calibration of the pixels during field operation, defects during manufacturing, or failures in the field), the resulting digitally reconstructed image can compensate for that based on the information from the remaining functional pixels. The processor **60** receives signals or data from the readout integrated circuit and executes an image reconstruction program **62** to construct a higher resolution image from the multiple low-resolution images from the various lenses in the array **84**. Examples of suitable image reconstruction programs are those used in multi-spectral, super-resolution, and/or plenoptic imaging schemes. Computer programs may be stand-alone software entities or sub-entities (e.g., subroutines, code objects) of other computer programs.

[0094] Fig. 26 is a block diagram illustrating the imaging of a scene with one or more GRIN lenses and reconstruction of the original image by digital reconstruction and/or super-resolution techniques. Each focused spot of electromagnetic radiation individually forms an image on a corresponding pixel sub-array in a focal plane array. For example, one may obtain nine independent images with a 3x3 array of pixels in a focal plane. These nine images can be processed to computationally reconstruct a higher resolution image that approaches the original image.

[0095] Fig. 27 shows an example of a 3x1 element array **85** of planar GRIN lenses formed in the same lens substrate **86**. The three lenses that are formed in the lens substrate **86** are arranged in the same plane with each other. The three lenses have different orientations of their optical axes. The first lens has an optical axis that is offset by an angle θ_1 from a line normal to the lens substrate **86**, the second lens has an optical axis that is normal to the lens substrate **86**, and the third lens has an optical axis that is offset by an angle θ_2 from a line normal to the lens substrate **86**. One possible approach that may be used to tilt the optical axis of a GRIN lens is to implement a spatial bias within a pattern of sub-wavelength micro-features (e.g., trenches or holes) to induce the variation in the refractive properties of the resulting lens. A configuration in which at least two of the lenses in a lens system have different optical axes is useful in some embodiments for providing a desired field of view and/or for directing the incident electromagnetic radiation to desired focused spots on the FPA/ROIC substrate **20**.

[0096] In some embodiments, a planar GRIN lens may comprise two or more stacked substrates that are attached (e.g., bonded) together. Such substrate stacking schemes may be implemented to support several objectives, such as overcoming DRIE aspect ratio limitations

and providing mechanical robustness. It is understood that references to a lens substrate throughout the present disclosure may refer to either a single substrate or to a stack comprising a plurality of substrates.

[0097] Fig. 28 is a block diagram showing an idealized deep reactive ion etching (DRIE) process that may produce micro-features with vertical sidewalls. However, an actual DRIE process is typically characterized by a finite sidewall angle as depicted by the sidewall angle θ in Fig. 29. In some examples, the sidewall angle θ is in the range of 80° to 100° from the plane of the substrate. In some examples, the sidewall angle is stepped (i.e., assumes more than one value over the depth of a feature). In some embodiments, it is advantageous to form planar GRIN lenses with trenches or holes having a depth in the range of 40 to 200 μm (to achieve desired focusing power) and a width or diameter in the range of 0.5 to 4 μm (to satisfy the EMT criterion). Thus, in some embodiments, the depth-to-width aspect ratio for the trenches or holes may be in the range of about of 12:1 to 400:1, and preferably greater than or equal to 30:1. However, a typical silicon DRIE process may only readily support an aspect ratio in the range of 40:1 to 145:1. In some such cases, it is possible to scale the maximum effective achievable etch aspect ratio by forming a stack of separately etched substrates.

[0098] Fig. 30 shows a keyhole-shaped profile of the micro-features, achieved by stacking two etched substrates **88A** and **88B**. The first substrate **88A** is stacked on the second substrate **88B** such that etched trenches or holes **89A** in the first substrate are aligned with corresponding trenches or holes **89B** in the second substrate to form combined trenches or holes. Each of the combined trenches or holes preferably has a width or diameter that is less than a wavelength of incident electromagnetic radiation, the spacing between adjacent ones of the combined trenches or holes is less than the wavelength of the electromagnetic radiation, and the size and spacing of the combined trenches or holes in the stacked substrates **88A** and **88B** are sufficient to produce an effective refractive index profile of the lens element that is graded (e.g., varying as a function of radial position from its center). Fig. 31 shows another embodiment of a GRIN lens having combined trenches or holes with diamond-shaped profiles achieved by stacking two etched substrates **90A** and **90B**.

[0099] As a specific example of stacking substrates, a DRIE process with 40:1 aspect ratio may be used to form a series of trenches or through-holes in two separate silicon (Si) substrates. Each of the substrates has a thickness of 80 μm . The trenches or holes have a

width or diameter of about 2 μm . The two etched substrates are bonded (for example, using a fusion bonding process) such that the through-holes or trenches on each substrate are aligned to form combined trenches or holes. The result is stacked substrates having a combined thickness of 160 μm with holes or trenches having a width of only 2 μm , thereby doubling the effective aspect ratio enabled by the DRIE process from 40:1 to 80:1. In some embodiments, the etched Si layer is a device layer of a SOI wafer that is separated from the carrier wafer as part of the stacking process.

[00100] The desire for mechanical robustness may provide another incentive for stacking substrates to form a GRIN lens. A boxed in cross-section increases the bending stiffness of the lens, which may be desirable to resist a pressure differential imparted by a vacuum within a FPA cavity. A second use of an enclosed substrate is to protect fine etched micro-features (such as trenches or holes having high aspect ratios) from particulate contaminants, moisture absorption and mechanical damage sustained from contact with foreign objects. In some embodiments, at least one of the substrates forming the GRIN lens (or at least one lid attached to the substrate) has a substantially flat, planar surface enclosing the micro-features an entrance side through which the electromagnetic radiation enters the lens, and the micro-features are formed in an exit side of the substrate through which the electromagnetic radiation exits. In some embodiments, the exit side may also be enclosed, preferably by a substantially flat, planar surface. A third benefit of enclosed micro-features in a lens substrate(s) is increased thermal isolation across the thickness of the substrate by reducing convection heat transfer in the etched trenches or holes. Three possible approaches for forming enclosed micro-features in substrate stacks are illustrated in Figs. 32, 33 and 34.

[00101] In Fig. 32, a DRIE or other suitable process is used to form blind holes or trenches **93** in a silicon substrate **91**, thereby leaving a first enclosed surface **94**. A lid substrate **92**, formed for example using the device layer of a SOI wafer, may be bonded to the DRIE process side of the substrate **91** to form a second enclosed surface **95**. In Fig. 33, a DRIE or other suitable process is used to form through holes or trenches in a silicon substrate **96**. A first lid substrate **97A**, formed for example using the device layer of a SOI wafer, may be bonded to a first side of the substrate **96** to form a first enclosed surface. Similarly, a second lid substrate **97B**, also formed for example using the device layer of a SOI wafer, may be bonded to a second side of the substrate **96** to form a second enclosed surface. In Fig. 34, DRIE or other suitable processes are used to form blind holes or trenches in first and second

silicon substrates **98A** and **98B**, respectively, thereby leaving a first enclosed surface on each substrate. The etched sides of the first and second substrates **98A** and **98B** are bonded together, for example using a fusion bonding process, thereby forming fully enclosed micro-features (e.g., trenches or holes).

[00102] Fig. 35 shows an embodiment in which diffractive elements **99** are formed on a planar GRIN lens substrate **100** as distinct structures from the etched trenches or holes **101** that are used to impart the refractive behavior of the lens. The diffractive elements **99** may be formed using a thin film or etched into the bulk substrate **100**. Furthermore, the diffractive elements **99** may be formed on either or both surfaces of the lens substrate **100**. In other embodiments, diffractive elements may be implemented in several different ways. For example, in some embodiments, diffractive elements are incorporated and arranged with the etched micro-features that are used to impart the refractive behavior of the lens on a planar GRIN lens substrate. The diffractive elements may be formed in the lens substrate using, for example, a separate etch process. Diffractive optical elements are optional features to compensate for dispersion and optical aberrations within a planar GRIN lens.

[00103] Fig. 36 shows another embodiment of a gradient-index lens for focusing incident electromagnetic radiation. The lens comprises at least one substrate **102** having first and second opposing sides **104A**, **104B** (top and bottom sides in the drawing, although the relative orientation may vary during use). The first side **104A** has a first set of trenches or holes **106A** formed therein (e.g., blind holes or blind trenches that do not extend all the way through the substrate), and the second side **104B** has a second set of trenches or holes **106B** formed therein (e.g., blind holes or blind trenches that also do not extend all the way through the substrate). The size and spacing of the trenches or holes **106A**, **106B** formed in both of the sides of the substrate **102** are sufficient to produce an effective refractive index profile of the lens that is graded. In some embodiments, the refractive index profile is aspheric. Forming micro-features **106A**, **106B** in both sides of the substrate **102** is useful in embodiments where it is desired to remove more material from the substrate (e.g., by etching) to achieve a desired index of refraction.

[00104] Figs. 37A-F are schematic diagrams illustrating fabrication steps for producing the lens of Fig. 36, according to some embodiments of the invention. In Fig. 37A, the substrate **102** (e.g., a single-crystal silicon substrate) is ground to a desired thickness (e.g., 100 to 400 μm) and polished on first and second sides **104A**, **104B**. In Fig. 37B, oxide

hardmasks **108A**, **108B** (e.g., layers of silicon dioxide, each having a thickness in the range of 0.25 to 2 μm) are deposited on the first and second sides of the substrate **102**. The hardmasks **108A**, **108B** may be deposited on both sides of the substrate **102** simultaneously if performed by low-pressure chemical vapor deposition (LPCVD), or one side of the substrate **102** at a time if performing plasma-enhanced chemical vapor deposition (PECVD) or physical vapor deposition (PVD). In Fig. 37C, the hardmask **108A** is patterned by lithography and etching to a corresponding pattern for the trenches or holes to be etched in the first side of the substrate **102**. In Fig. 37D, the hardmask **108B** is patterned by lithography and etching to a corresponding pattern for the trenches or holes to be etched in the second side of the substrate **102**.

[00105] In Fig. 37E, the micro-features **106A** (e.g., trenches or holes) are formed in the top side of the substrate **102** preferably by deep reactive ion etching. The trenches or holes preferably have a depth in the range of 20 to 100 μm and a width or diameter in the range of 0.5 to 4 μm . In Fig. 37F, the micro-features **106B** (e.g., trenches or holes) are formed in the second side of the substrate **102** by deep reactive ion etching (e.g., to a depth in the range of 20 to 100 μm). The hardmasks **108A**, **108B** are removed (e.g., using HF vapor) to result in the structure of the substrate **102** shown in Fig. 36. Many other fabrication techniques are possible in alternative embodiments. For example, in some embodiments it is helpful to use one or more handle wafers if the substrate **102** is too thin after grinding and/or delicate after the first DRIE step. A handle or carrier wafer may be bonded to the substrate **102** to provide support or ease of handling, and then later removed.

[00106] Fig. 38 is a schematic side view of another GRIN lens, according to some embodiments of the invention. The lens includes the substrate **102** (described above with micro-features formed in both sides) and a second substrate **110** having at least one side with another set of trenches or holes formed therein. The substrates **102**, **110** are attached to each other (e.g., bonded) such that the trenches or holes in the substrate **110** are substantially aligned with trenches or holes in the substrate **102** to form combined trenches or holes **107** that are fully enclosed. The substrate **110** optionally includes micro-features etched into its first and second sides, similar to the substrate **102**. In this case, an optically transmissive lid **112** (e.g., a substrate) is useful. One side of the stack of substrates **102**, **110** that may be exposed to the surrounding environment during use of the lens is capped with a silicon lid **112** to keep out contaminants and protect the micro-features. Alternatively, both sides of the

stack of substrates **102**, **110** may be capped with lids. In some embodiments, the second substrate **110** may only have blind holes or trenches etched in one side that is attached to the first substrate **102**, in which case a lid may not be necessary. Diffractive elements may be etched in the second substrate **110**, similar to the diffractive elements shown in Fig. 30.

[00107] The description above illustrates embodiments of the invention by way of example and not necessarily by way of limitation. Many other values may be selected for the specific depths, trench or hole sizes, and index coefficients, as well as different combinations of parameters and/or materials. The GRIN lenses may be incorporated into a camera having an optically transmissive lid (e.g., formed using germanium or silicon) that is provided as part of the overall vacuum package and that serves as a window for incident IR radiation. The infrared (IR) camera typically includes a camera core comprising a Focal Plane Array (FPA), a lens system and an enclosure. The FPA typically comprises multiple elements – the underlying Read-Out Integrated Circuit (ROIC), the thermistor or micro-bolometer pixel array which is built on top of the ROIC, usually on the same silicon wafer and integrated with the ROIC, and a “packaged window” or lid (e.g., formed using germanium or silicon) which is substantially transparent to incoming IR radiation and which is bonded on top of the FPA with a hermetic vacuum seal. A single GRIN lens or a system of GRIN lenses is mounted on top of the FPA (e.g., one or more GRIN lenses may be screwed on or molded to a housing).

[00108] In some embodiments, one or more GRIN lenses formed in at least one substrate may form the vacuum package with the FPA, eliminating the need for a separate “packaged window” or lid. In some embodiments, refractive optical elements may be provided, such as an etched refractive surface formed in one or more lens substrates. Imaging devices (e.g., camera cores) may include just one lens substrate and one pixel, or the imaging devices may comprise multiple lenses, lens substrates and/or pixel arrays. The imaging devices may be used in a wide range of applications such as expanded security, surveillance, first responder, and automotive applications.

[00109] The planar GRIN lens substrate may further comprise a series of lens carriers, wherein each lens carrier comprises a “shelf” or “ledge” structure to align and support a corresponding discrete lens, and a through “window” to pass incident electromagnetic radiation. A discrete lens may be positioned onto a corresponding lens carrier using, for example, a pick and place process. In some configurations, a discrete lens is attached to the lens carrier using a hermetic bond formed using, for example, a fusion bonding, brazing, or

solder process. Multi-spectral imaging schemes may thus be implemented by pairing individual lenses on a lens substrate to corresponding detectors on a FPA substrate. As an example, a lens substrate may be formed having a monolithic planar GRIN lens disposed over a micro-bolometer-based FPA to support infrared imaging and a discrete lenticular glass lens assembled in a lens carrier disposed over a CMOS-based FPA to support visible light imaging. This modular approach to multi-spectral imaging may be readily extended to additional bands of electromagnetic radiation including, for example, near-infrared (NIR) and ultraviolet (UV), using suitable pairs of lenses and detectors.

[00110] Accordingly, the scope of the invention should be determined by the following claims and their legal equivalents.

CLAIMS

What is claimed is:

1. A gradient-index lens for directing incident electromagnetic radiation, the lens comprising at least one substrate having a plurality of curved trenches formed therein, wherein each of the curved trenches has at least one dimension that is less than a wavelength of the electromagnetic radiation, each of the trenches has a ratio of length to width that is greater than or equal to 3:1, the spacing between adjacent trenches is less than the wavelength of the electromagnetic radiation, and an effective refractive index profile of the lens is graded.
2. The lens of claim 1, wherein each of the curved trenches has a cross-sectional area in a plane substantially perpendicular to a line defining the depth of the trench, and the cross-sectional area is substantially shaped like an arc, spiral, circle or ring.
3. The lens of claim 1, wherein the curved trenches are shaped like arcs that are arranged in a pattern of substantially concentric circles or rings having discontinuities that are less than the wavelength of the electromagnetic radiation.
4. A camera comprising at least one pixel in a focal plane, wherein the lens of claim 1 is arranged to direct the electromagnetic radiation to the pixel.
5. The camera of claim 4, further comprising at least one readout circuit electrically connected to the pixel, and further comprising at least one processor in communication with the circuit, wherein the processor is programmed to construct an image from pixel signals.
6. The lens of claim 1, wherein each of the trenches has at least one dimension that is in the range of 150 nm to 15 μ m, and the spacing between adjacent trenches is the range of 150 nm to 15 μ m.
7. The lens of claim 1, wherein the lens has a substantially flat surface enclosing the trenches on an entrance side through which the electromagnetic radiation enters the lens, and

wherein the trenches are formed in an exit side of the substrate through which at least a portion of the electromagnetic radiation exits.

8. The lens of claim 1, further comprising diffractive elements formed in the substrate.
9. The lens of claim 1, wherein each of the trenches has a depth in the range of 40 to 200 μm and a width in the range of 0.5 to 4 μm .
10. The lens of claim 1, wherein a majority of the trenches have an aspect ratio of depth to width greater than or equal to 30:1.
11. The lens of claim 1, wherein the substrate has first and second opposing sides, a first set of the trenches is formed in the first side, and a second set of the trenches is formed in the second side.
12. A gradient-index lens for directing incident electromagnetic radiation, the lens comprising at least one substrate having a plurality of trenches or holes formed therein, wherein each of the trenches or holes has at least one dimension that is less than a wavelength of the electromagnetic radiation, the spacing between adjacent trenches or holes is less than the wavelength of the electromagnetic radiation, the size and spacing of the trenches or holes result in an effective refractive index profile of the lens that is graded, and the f-number divided by the diameter of the lens is less than 1.5.
13. The lens of claim 12, wherein each of the trenches or holes has at least one dimension that is in the range of 150 nm to 15 μm , and the spacing between adjacent trenches or holes is the range of 150 nm to 15 μm .
14. The lens of claim 12, wherein the f-number divided by the diameter of the lens is in the range of 0.05 to 1.5.
15. The lens of claim 12, wherein each of the trenches or holes has a depth in the range of 40 to 200 μm and a width or diameter in the range of 0.5 to 4 μm .

16. The lens of claim 12, wherein a majority of the trenches or holes have an aspect ratio of depth to width greater than or equal to 30:1.

17. The lens of claim 12, wherein the substrate has first and second opposing sides, a first set of the trenches or holes is formed in the first side, and a second set of the trenches or holes is formed in the second side.

18. The lens of claim 12, further comprising diffractive elements formed in the at least one substrate.

19. A camera comprising at least one pixel in a focal plane, wherein the lens of claim 12 is arranged to direct the electromagnetic radiation to the pixel.

20. The camera of claim 19, further comprising at least one readout circuit electrically connected to the pixel, and further comprising at least one processor in communication with the circuit, wherein the processor is programmed to construct an image from pixel signals.

21. A thermal imaging device comprising:

- a) at least one pixel disposed on a focal plane substrate;
- b) at least one gradient-index lens comprising at least one lens substrate having a plurality of micro-features formed therein, wherein an effective refractive index profile of the lens is graded, the lens is positioned to direct incident electromagnetic radiation to the pixel, and the lens substrate is arranged with the focal plane substrate to enclose the pixel in a vacuum in a space between the lens substrate and the focal plane substrate; and
- c) at least one readout circuit electrically connected to the pixel.

22. The device of claim 21, further comprising a second gradient-index lens arranged to direct the incident electromagnetic radiation to the at least one lens, wherein the index coefficients of the lenses are selected to provide a field of view for the incident electromagnetic radiation of at least 30°.

23. The device of claim 22, further comprising a third gradient-index lens arranged to direct the incident electromagnetic radiation to the second lens, wherein the index

coefficients of the lenses are selected to provide a field of view for the incident electromagnetic radiation of at least 60° .

24. The device of claim 21, wherein the lens substrate is arranged with the focal plane substrate by means of at least one standoff structure positioned between the lens substrate and the focal plane substrate such that the standoff structure forms walls around the periphery of the enclosed space between the lens substrate and the focal plane substrate.

25. The device of claim 21, further comprising at least one lid substrate positioned between the lens substrate and the focal plane substrate.

26. The device of claim 21, wherein the at least one lens comprises a plurality of gradient-index lenses arranged in substantially the same plane with each other, and at least two of the lenses have different optical axes.

27. The device of claim 21, wherein the at least one lens comprises a plurality of gradient-index lenses formed in the same lens substrate.

28. The device of claim 21, wherein the micro-features comprise trenches or holes, and each of the trenches or holes has a depth in the range of 40 to 200 μm and a width or diameter in the range of 0.5 to 4 μm .

29. The device of claim 28, wherein a majority of the trenches or holes have an aspect ratio of depth to width greater than or equal to 30:1.

30. A camera incorporating the imaging device of claim 21.

31. The camera of claim 30, further comprising at least one processor in communication with the readout circuit, wherein the processor is programmed to construct an image from pixel signals.

32. The device of claim 21, wherein the micro-features comprise pores.

33. A gradient-index lens for directing incident electromagnetic radiation, the lens comprising at least first and second substrates, wherein each of the substrates has a plurality of trenches or holes formed therein, the first substrate is stacked on the second substrate such that the trenches or holes in the first substrate are aligned with corresponding trenches or holes in the second substrate to form combined trenches or holes, and an effective refractive index profile of the lens is graded.

34. The lens of claim 33, wherein at least some of the combined trenches or holes comprise L-shaped trenches.

35. The lens of claim 33, wherein at least some of the combined trenches or holes comprise trenches that are arranged in a pattern of spokes or crosses.

36. The lens of claim 33, wherein at least some of the combined trenches or holes comprise curved trenches, each of the curved trenches has a cross-sectional area in a plane perpendicular to a line defining the depth of the trench, and the cross-sectional area is shaped like an arc, spiral, circle or ring.

37. The lens of claim 33, wherein each of the combined trenches or holes has a depth in the range of 40 to 200 μm and a width or diameter in the range of 0.5 to 4 μm .

38. The lens of claim 33, wherein each of the combined trenches or holes has an aspect ratio of depth to width greater than or equal to 80:1.

39. The lens of claim 33, further comprising diffractive elements formed in at least one of the substrates.

40. A camera comprising at least one pixel in a focal plane, wherein the lens of claim 33 is arranged to direct the electromagnetic radiation to the pixel.

41. The camera of claim 40, further comprising at least one readout circuit electrically connected to the pixel, and further comprising at least one processor in communication with the circuit, wherein the processor is programmed to construct an image from pixel signals.

42. A method for fabricating a gradient-index lens for directing incident electromagnetic radiation, the method comprising:

- a) forming a plurality of trenches or holes in at least first and second substrates; and
- b) attaching the first substrate to the second substrate such that the trenches or holes in the first substrate are aligned with corresponding trenches or holes in the second substrate to form combined trenches or holes, wherein an effective refractive index profile of the lens is graded.

43. The method of claim 42, wherein each of the combined trenches or holes has a depth in the range of 40 to 200 μm and a width or diameter in the range of 0.5 to 4 μm .

44. The method of claim 42, wherein each of the combined trenches or holes has an aspect ratio of depth to width greater than or equal to 80:1.

45. The method of claim 42, further comprising the step of forming diffractive elements in at least one of the substrates.

46. The method of claim 42, wherein the step of forming a plurality of trenches or holes in the substrates comprises producing at least one mask made by halftone design on at least one surface of the substrates and etching the substrates.

47. A gradient-index lens for directing incident electromagnetic radiation, the lens comprising at least one substrate having first and second opposing sides, wherein the first side has a first set of blind holes or trenches formed therein, the second side has a second set of blind holes or trenches formed therein, and an effective refractive index profile of the lens is graded.

48. The lens of claim 47, wherein at least some of the trenches or holes comprise L-shaped trenches.

49. The lens of claim 47, wherein at least some of the trenches or holes comprise trenches that are arranged in a pattern of spokes or crosses.

50. The lens of claim 47, wherein at least some of the trenches or holes comprise curved trenches, each of the curved trenches has a cross-sectional area in a plane perpendicular to a line defining the depth of the trench, and the cross-sectional area is shaped like an arc, spiral, circle or ring.

51. The lens of claim 47, wherein each of the trenches or holes has a depth in the range of 20 to 100 μm and a width or diameter in the range of 0.5 to 4 μm .

52. The lens of claim 47, wherein each of the trenches or holes has an aspect ratio of depth to width that is greater than or equal to 30:1.

53. A camera comprising at least one pixel in a focal plane, wherein the lens of claim 47 is arranged to direct the electromagnetic radiation to the pixel.

54. The camera of claim 53, further comprising at least one readout circuit electrically connected to the pixel, and further comprising at least one processor in communication with the readout circuit, wherein the processor is programmed to construct an image from pixel signals.

55. The lens of claim 47, further comprising a second substrate having at least one side with a third set of trenches or holes formed therein, wherein the substrates are attached to each other such that the trenches or holes in the third set are aligned with the trenches or holes in either the first or the second set to form combined trenches or holes.

1/31

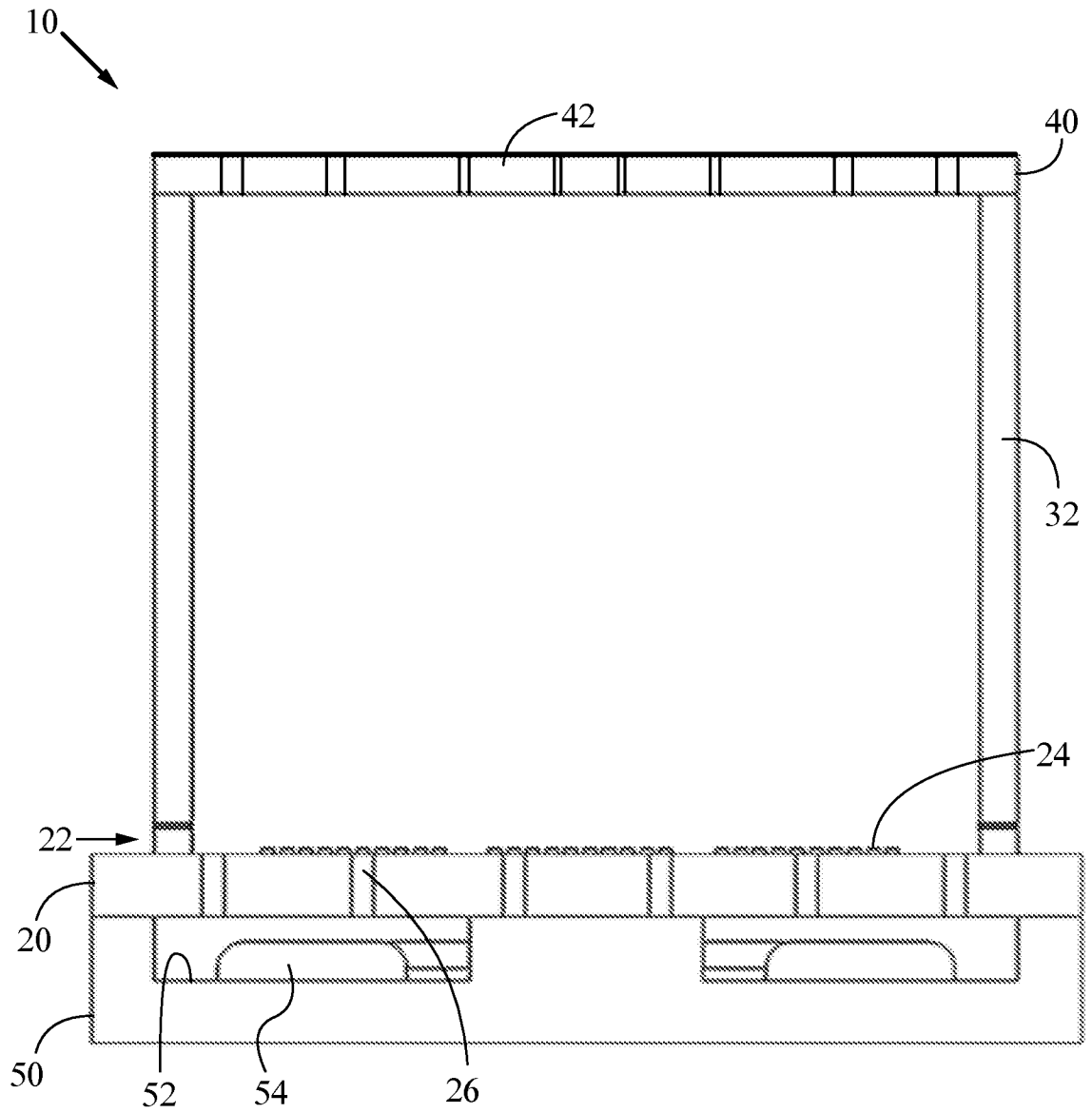

FIG. 1

2/31

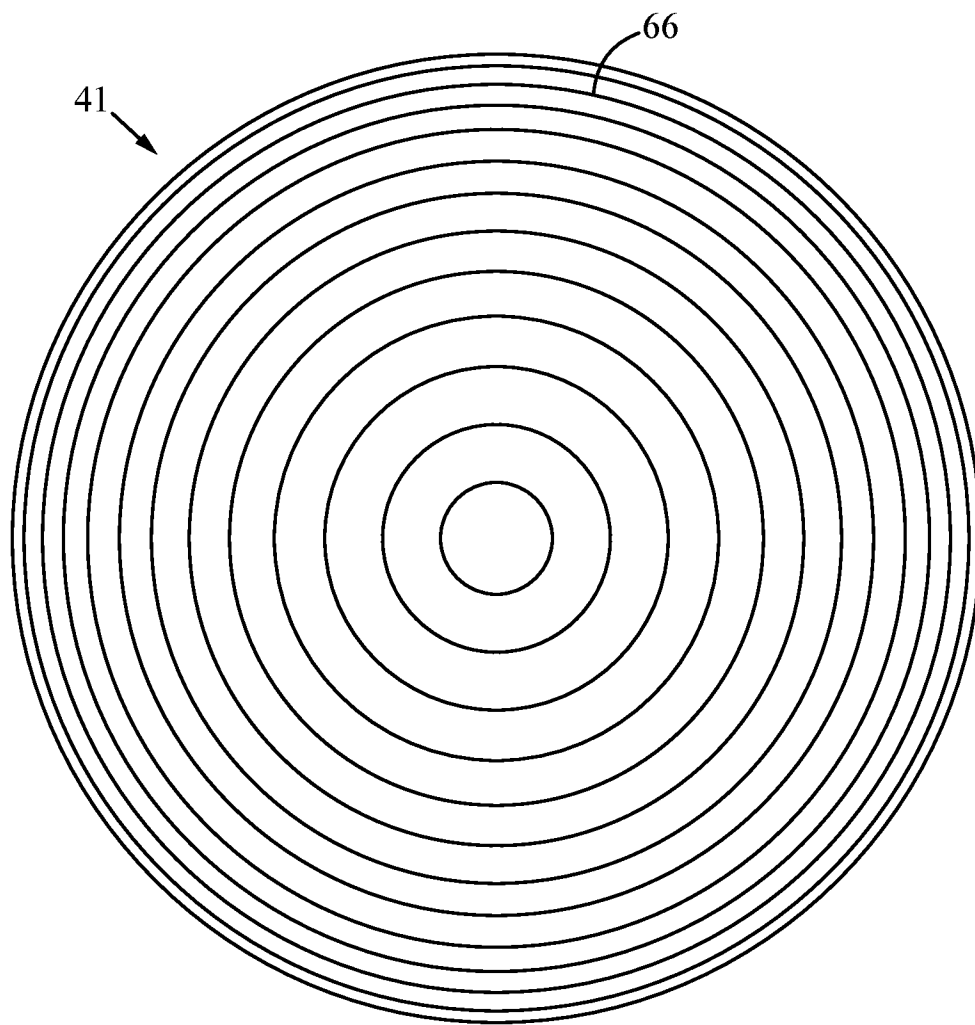

FIG. 2

3/31

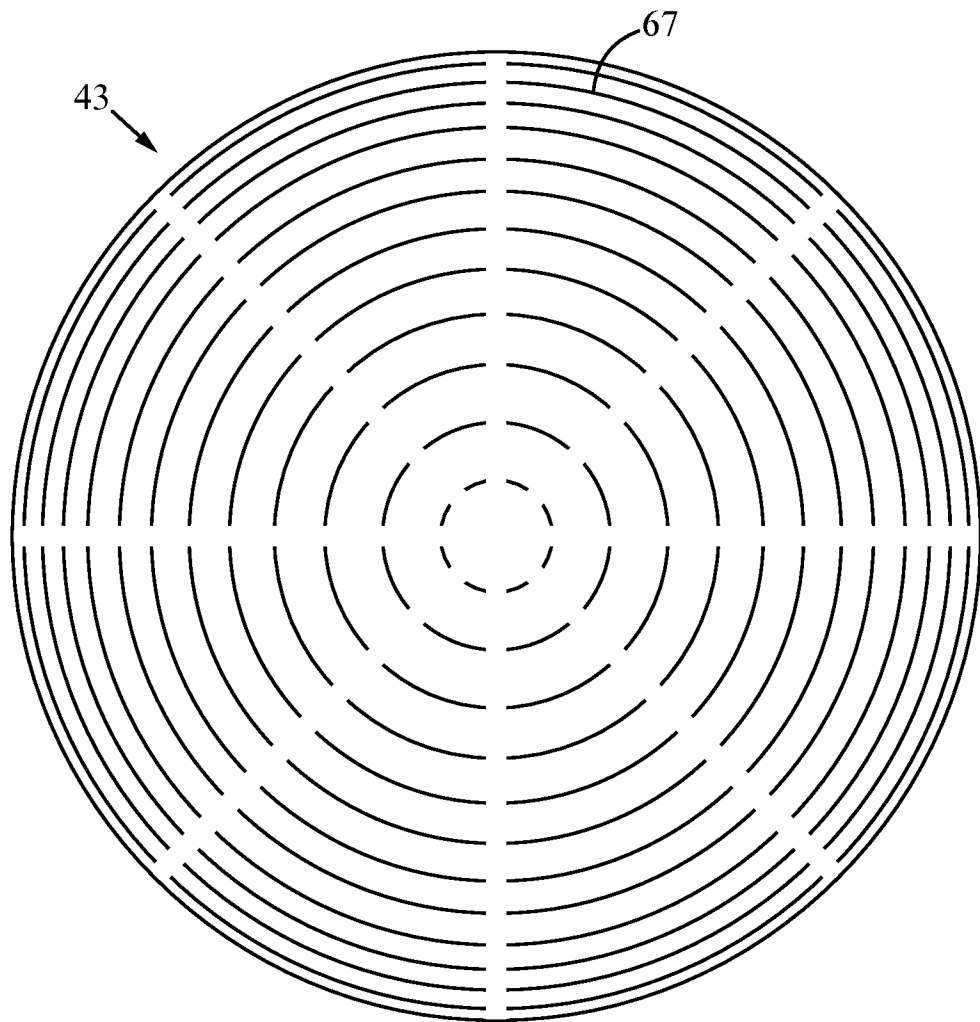

FIG. 3

4/31

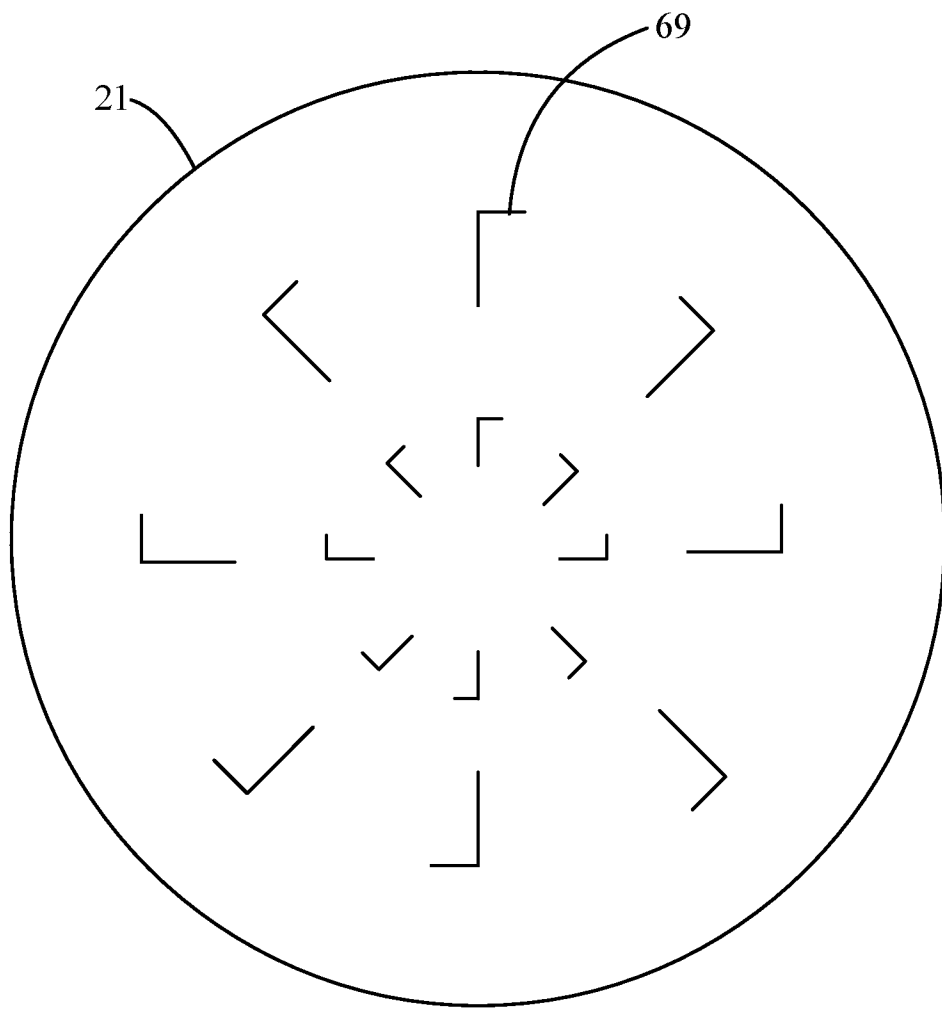

FIG. 4

5/31

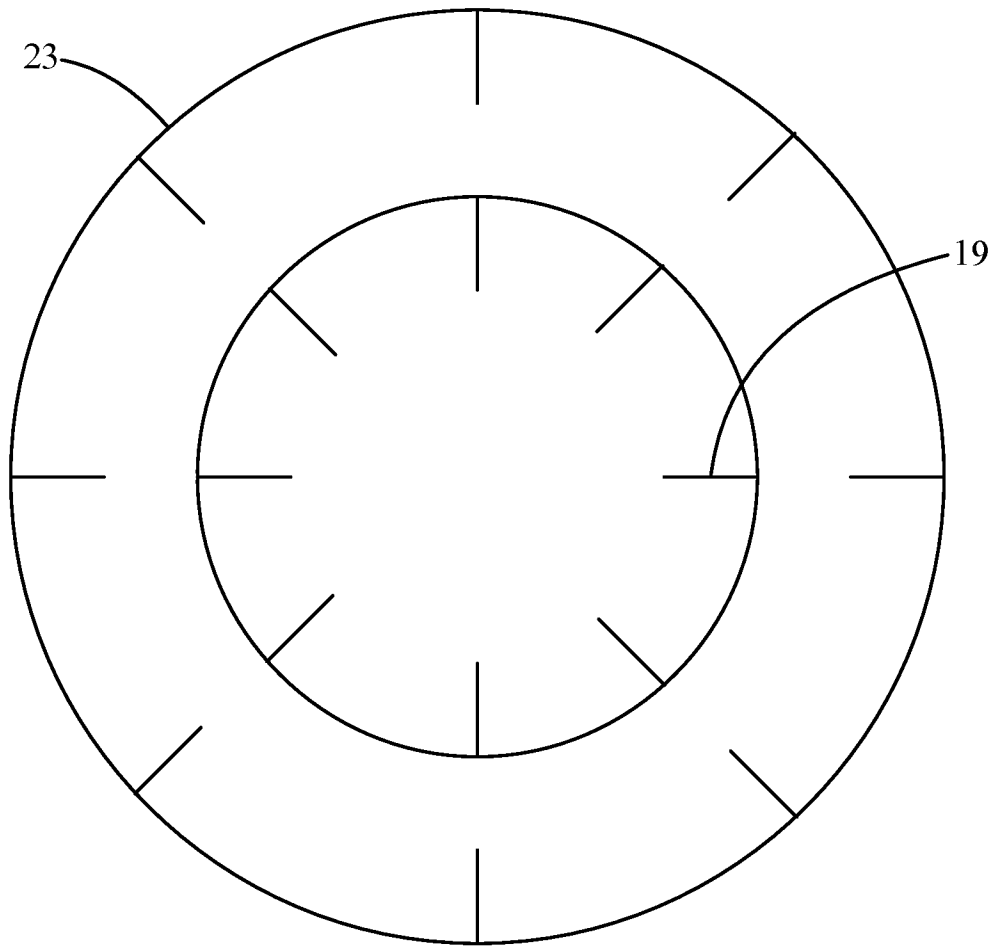

FIG. 5

6/31

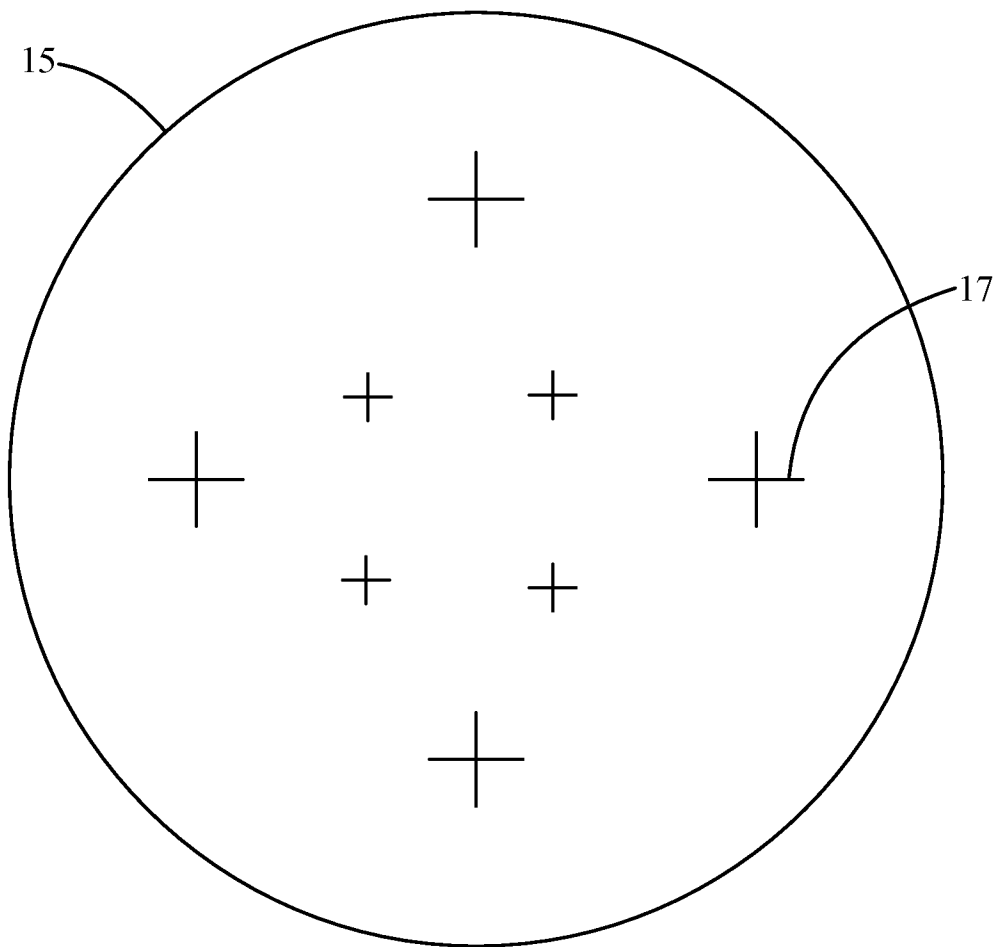

FIG. 6

7/31

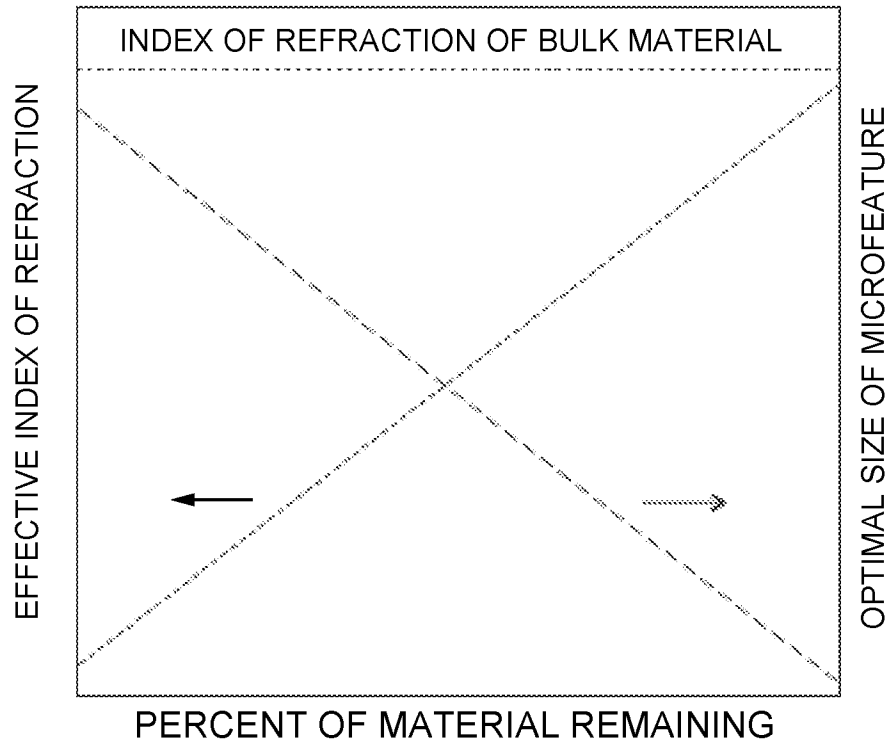

FIG. 7

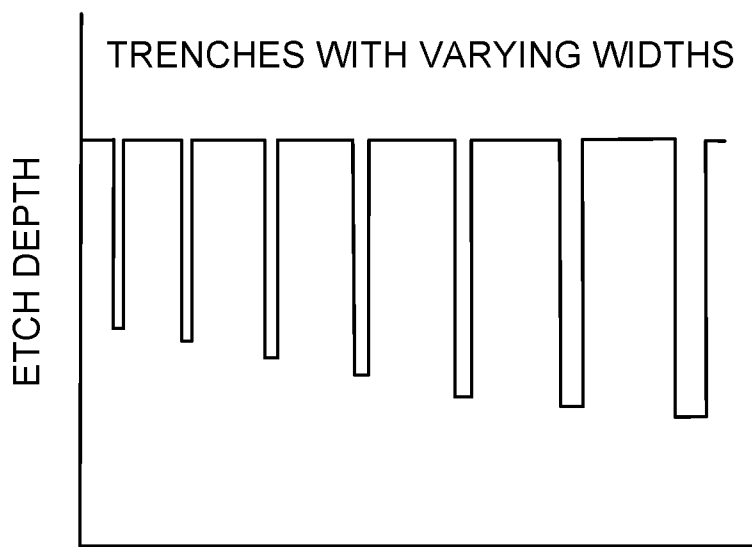

FIG. 8

8/31

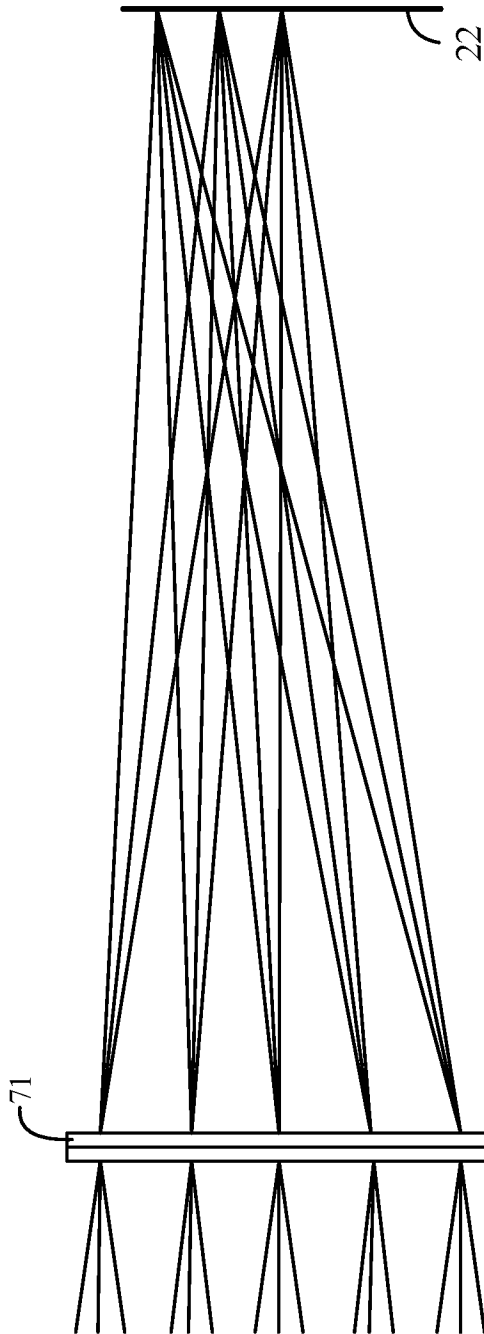

FIG. 9

9/31

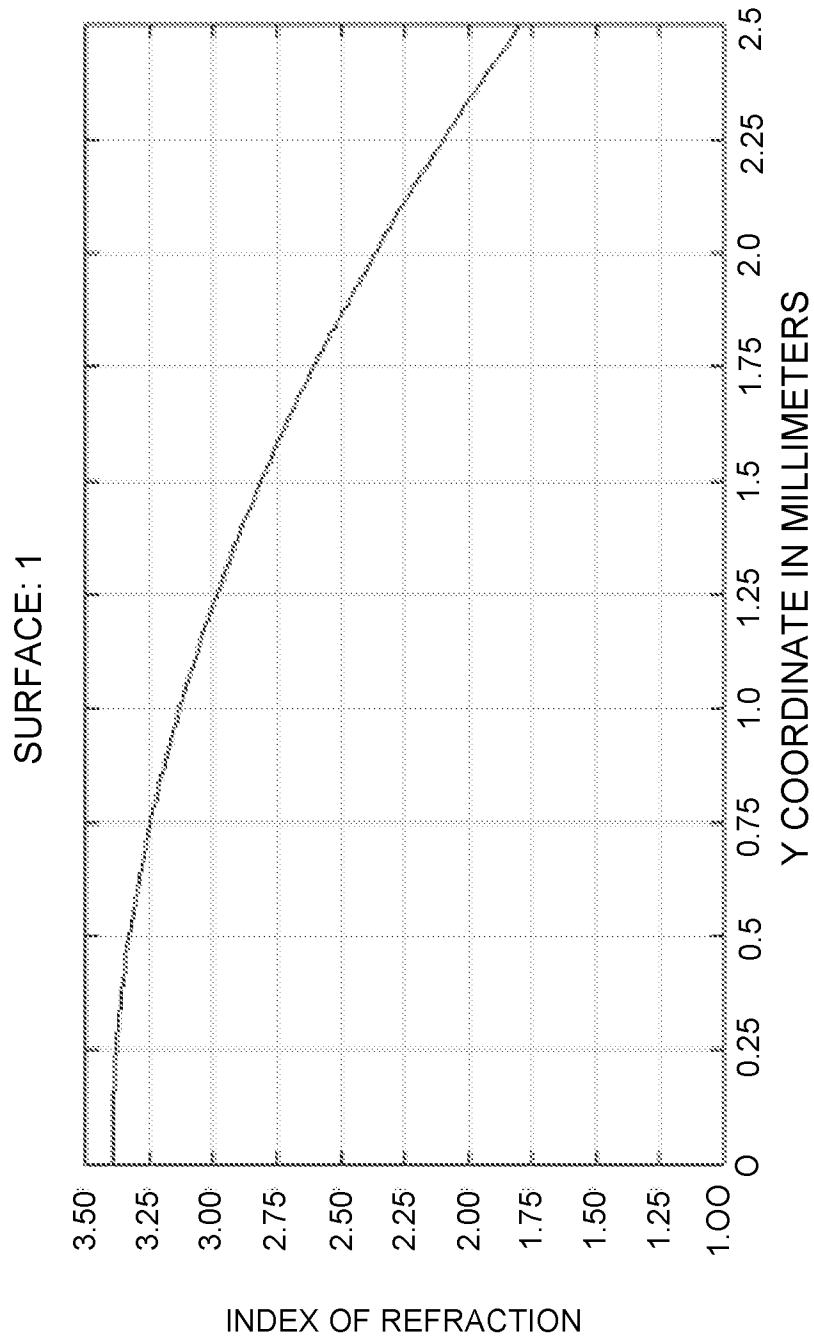

FIG. 10

10/31

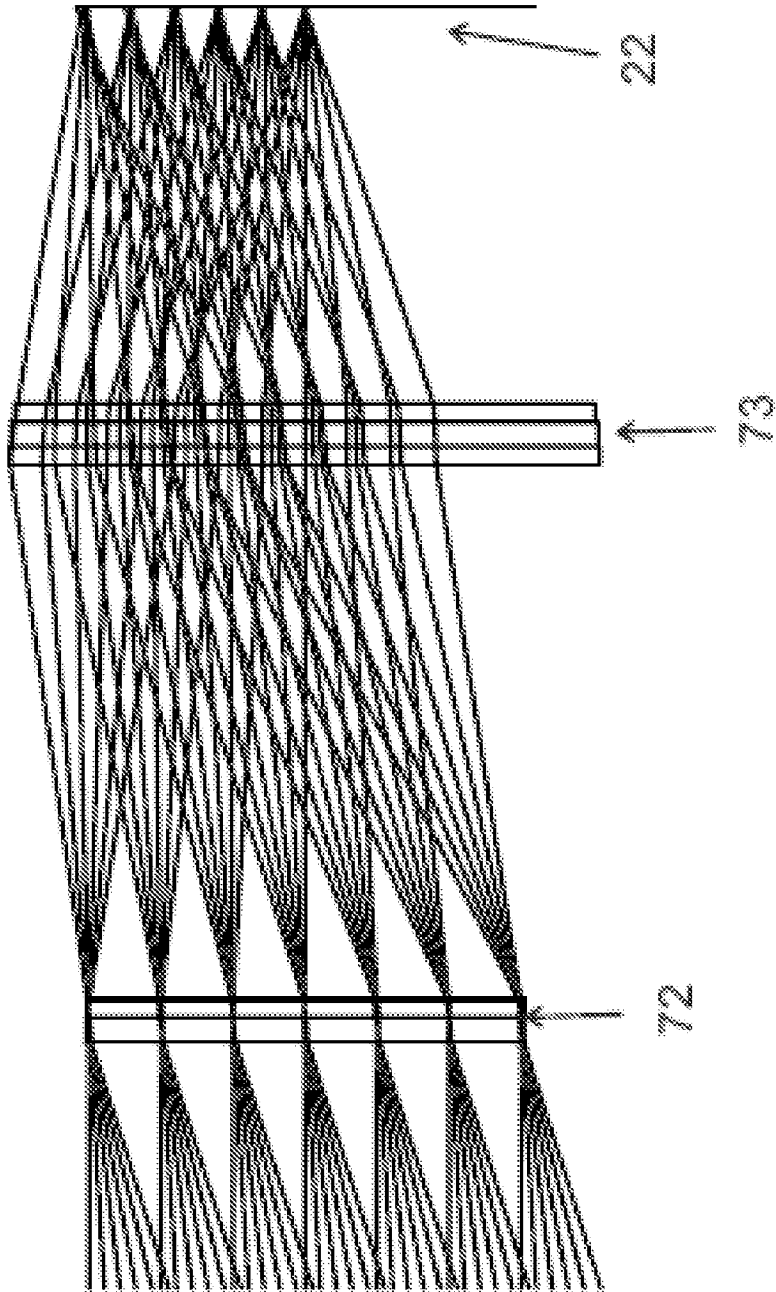

FIG. 11

11/31

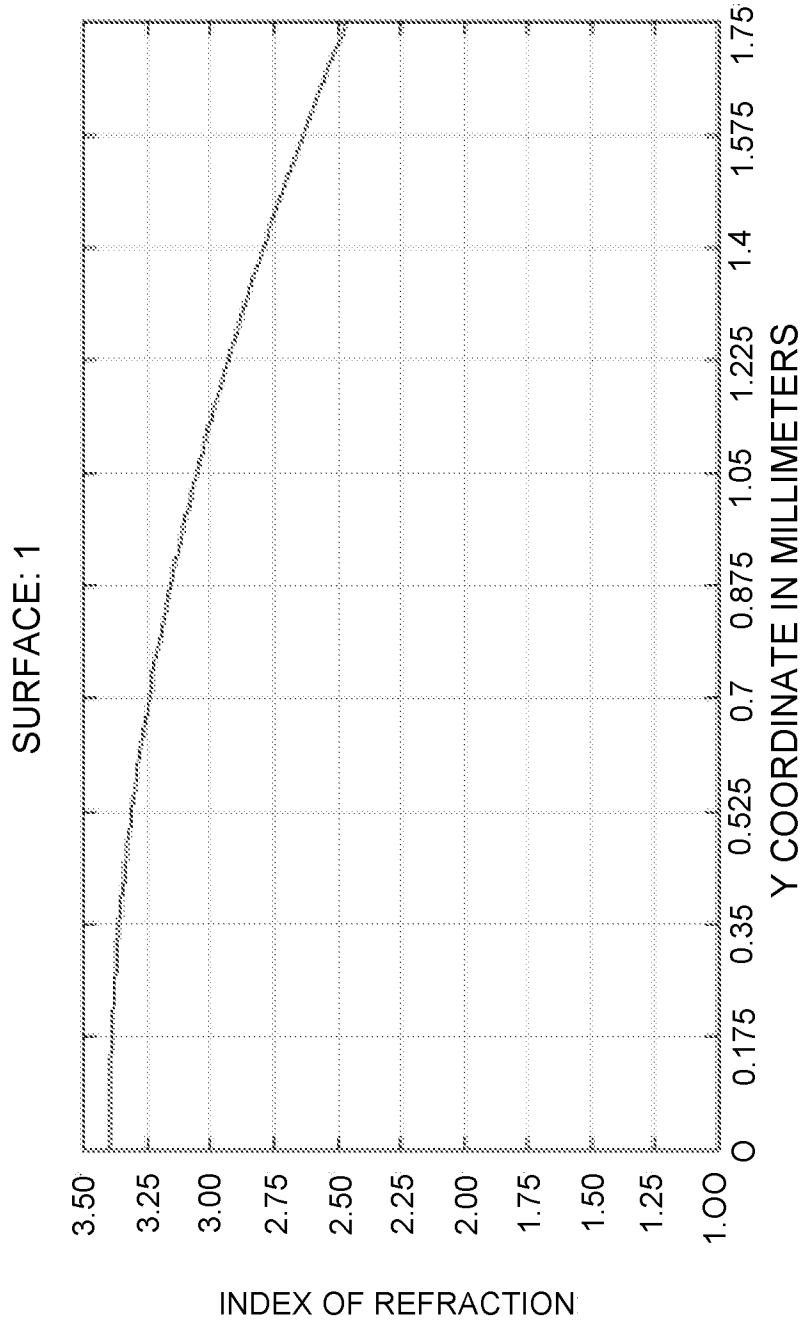

FIG. 12

12/31

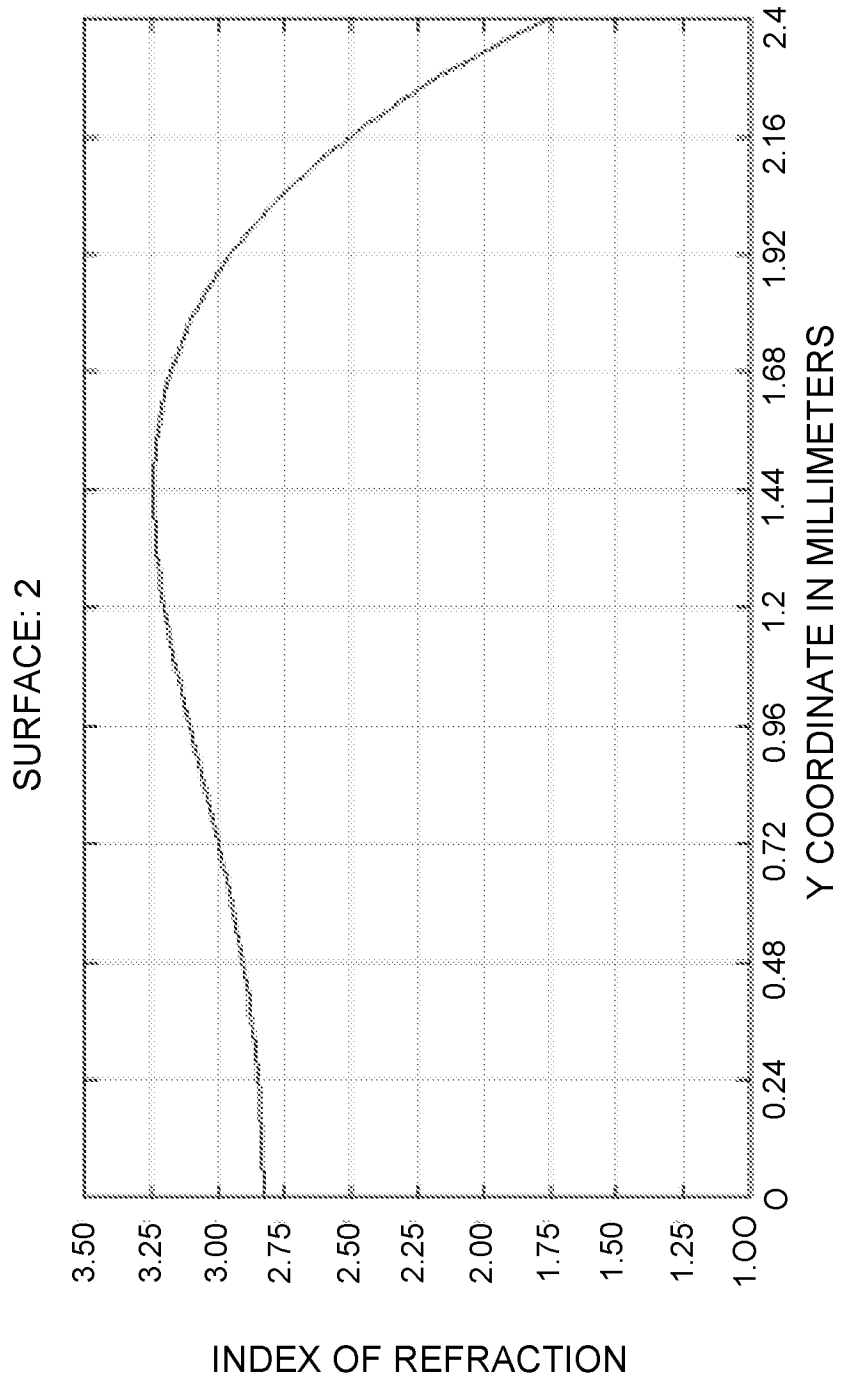

FIG. 13

13/31

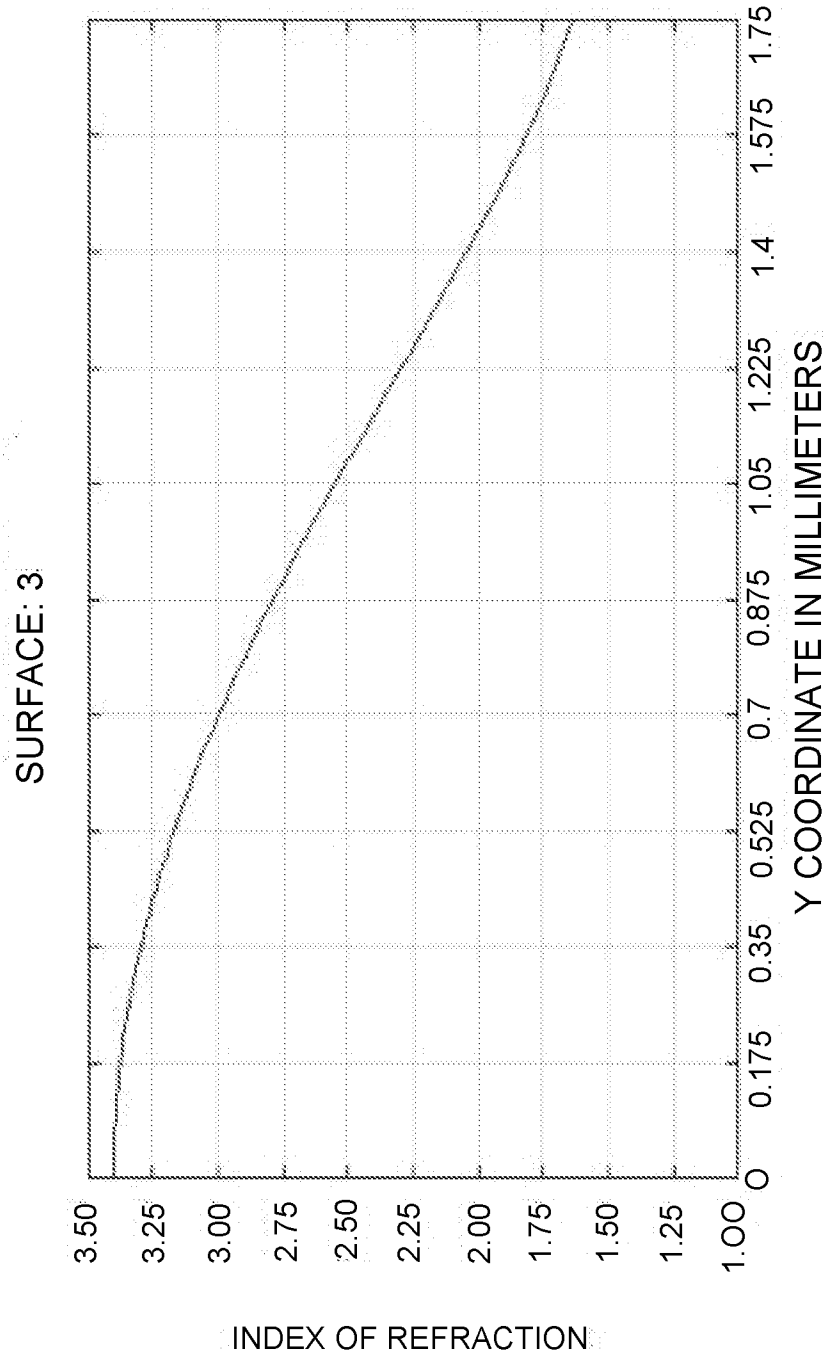

FIG. 14

14/31

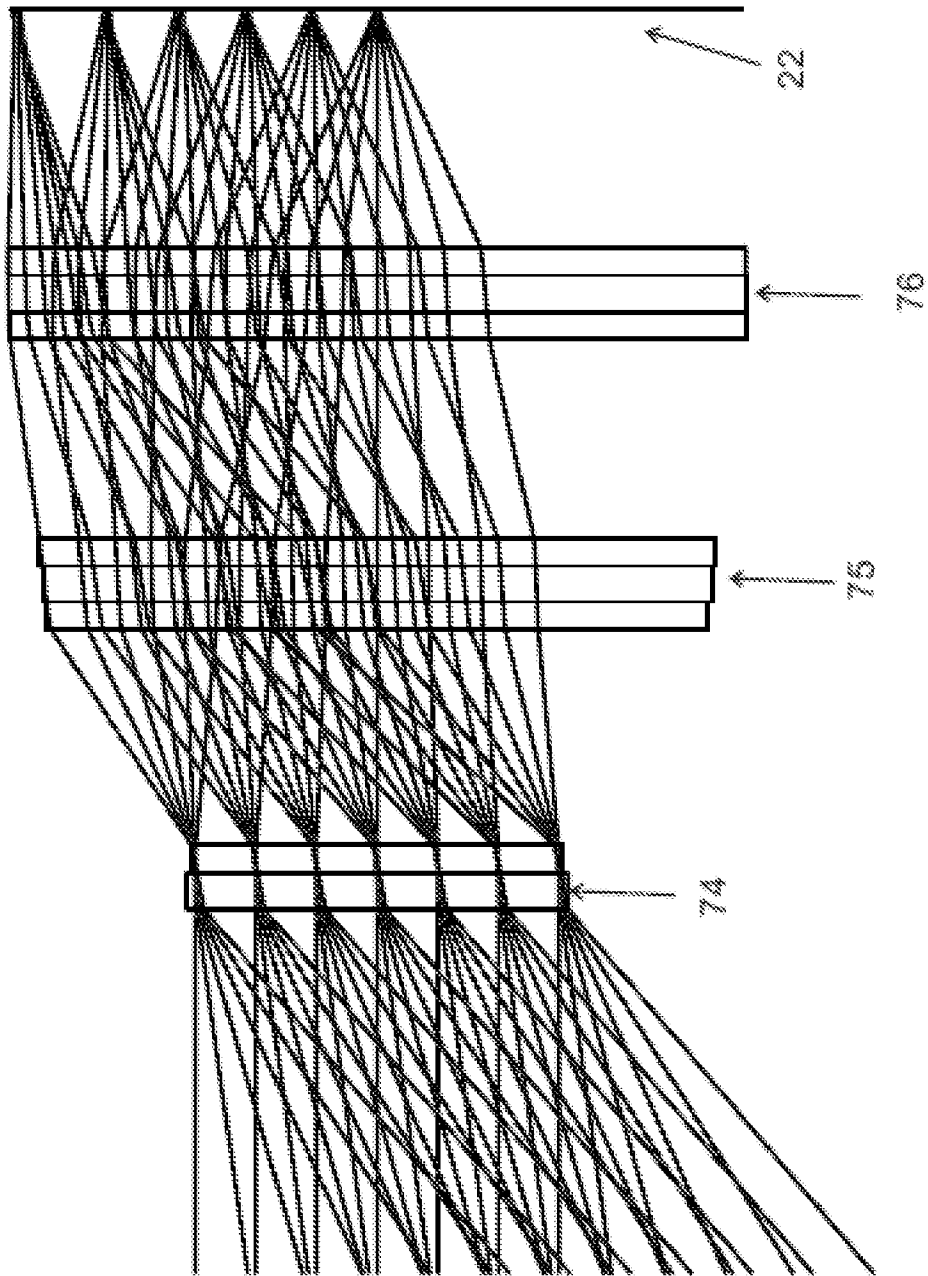

FIG. 15

15/31

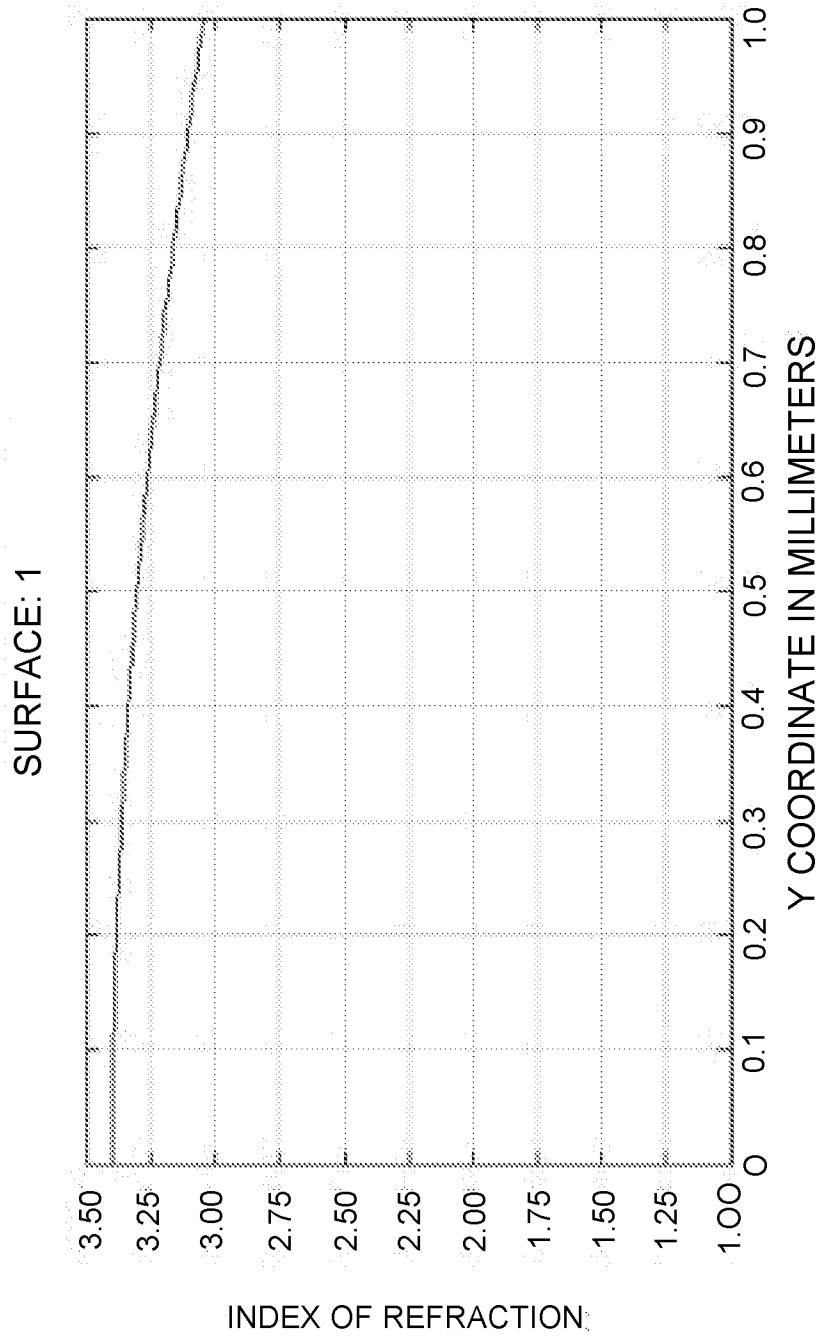

FIG. 16

16/31

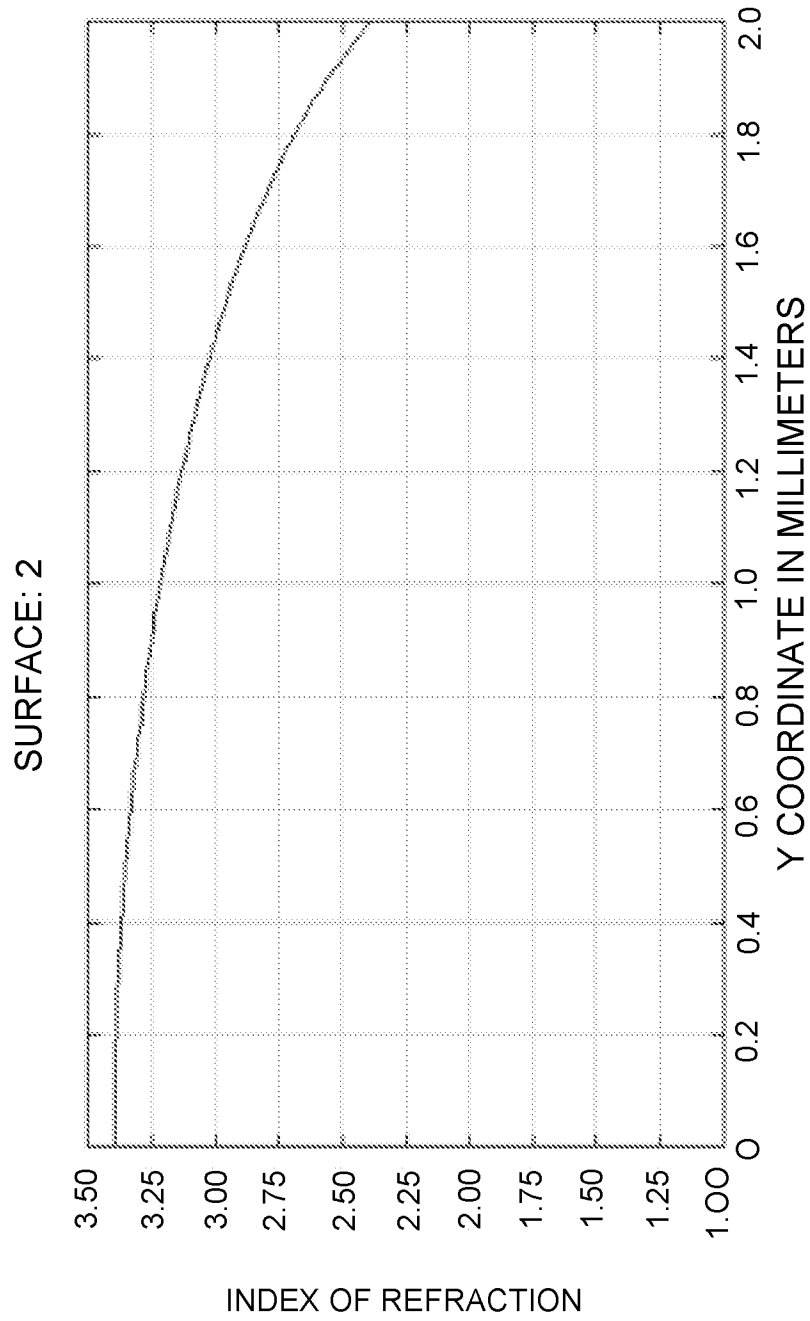

FIG. 17

17/31

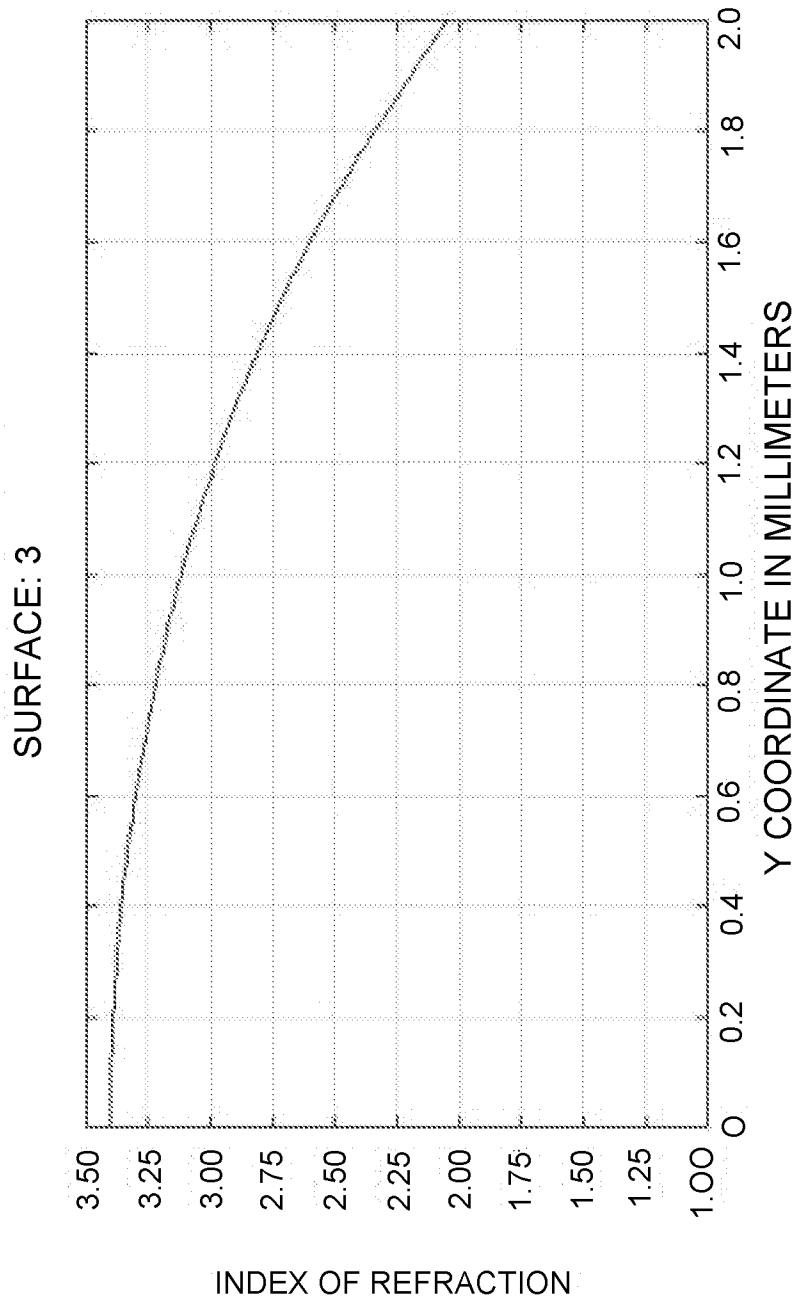

FIG. 18

18/31

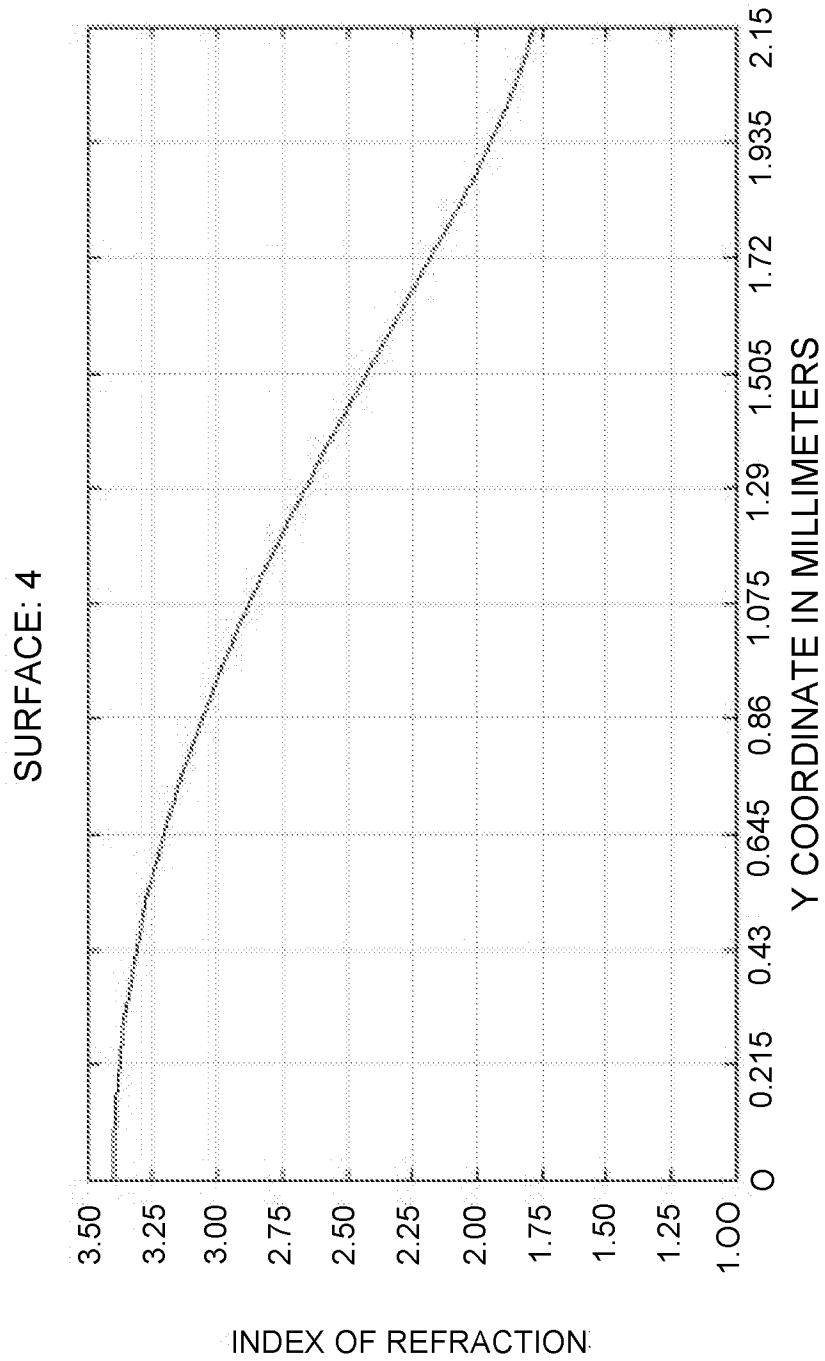

FIG. 19

19/31

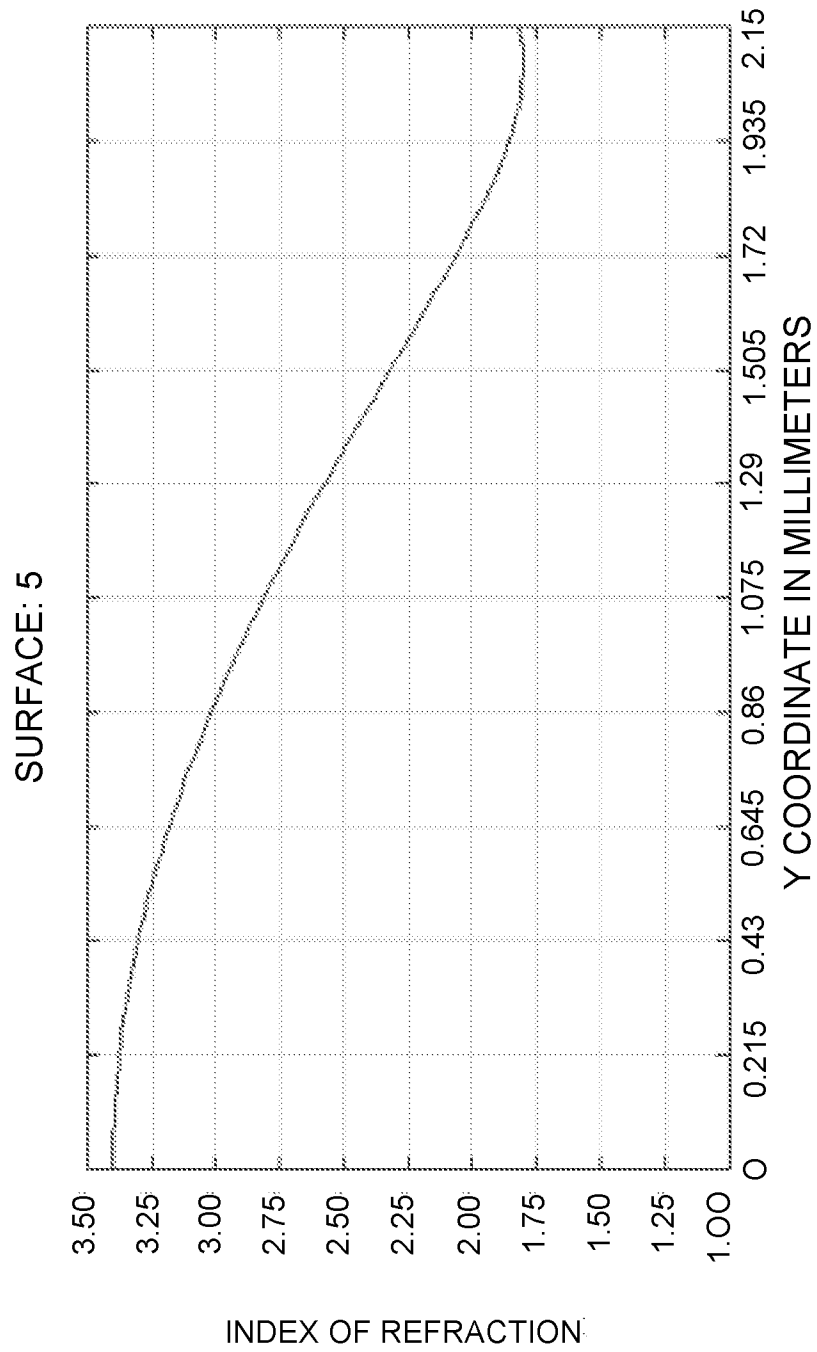

FIG. 20

20/31

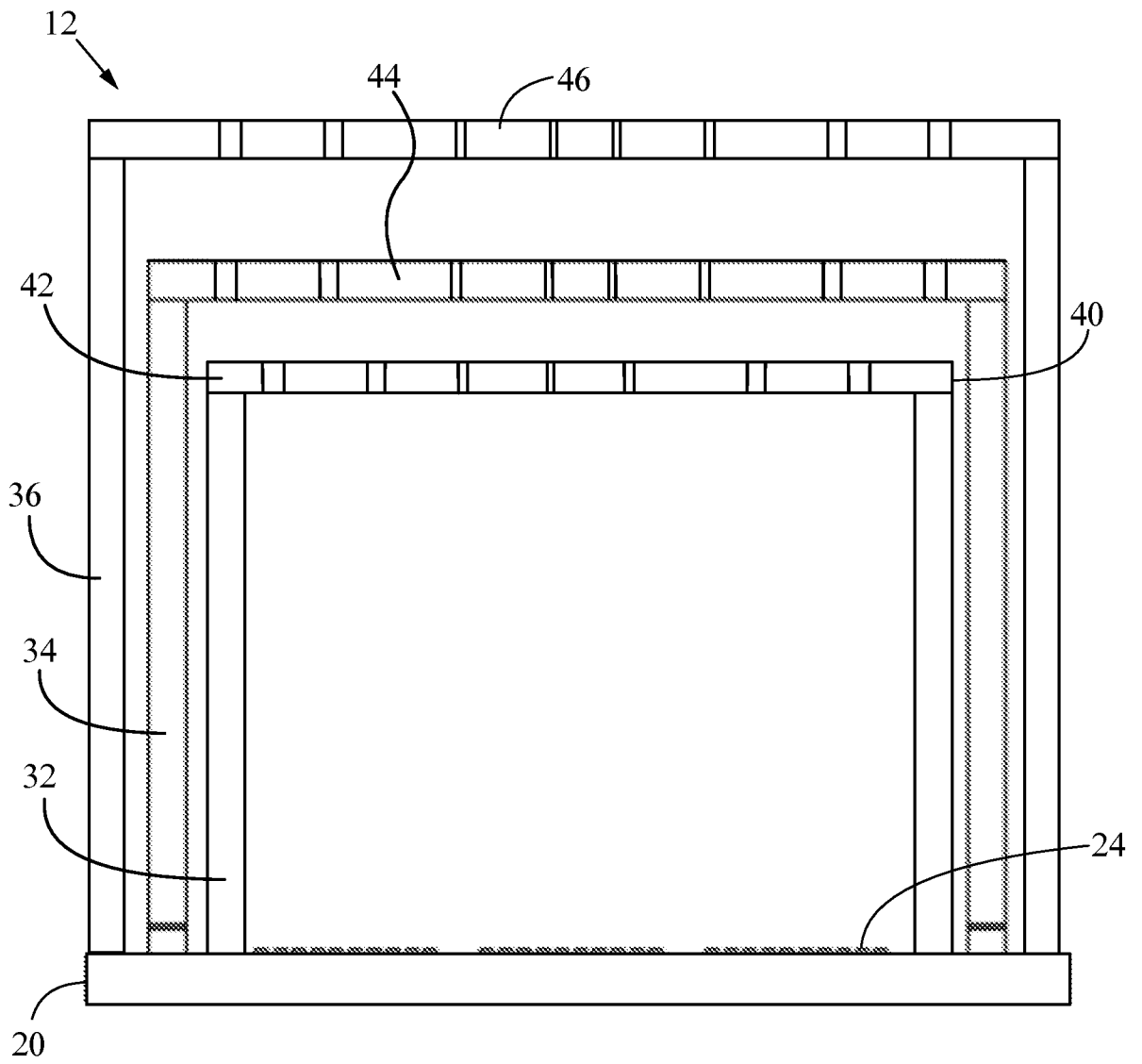

FIG. 21

21/31

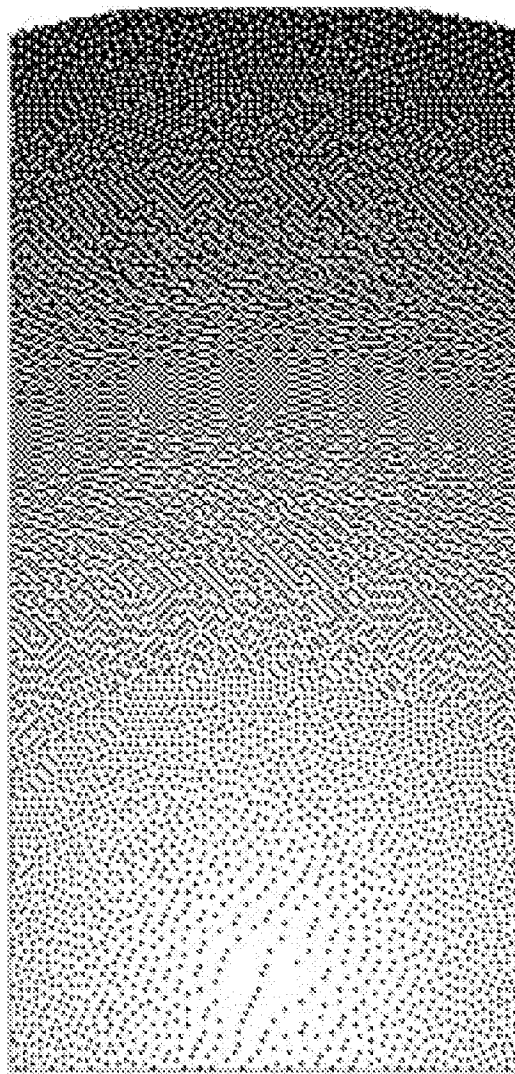

FIG. 22

22/31

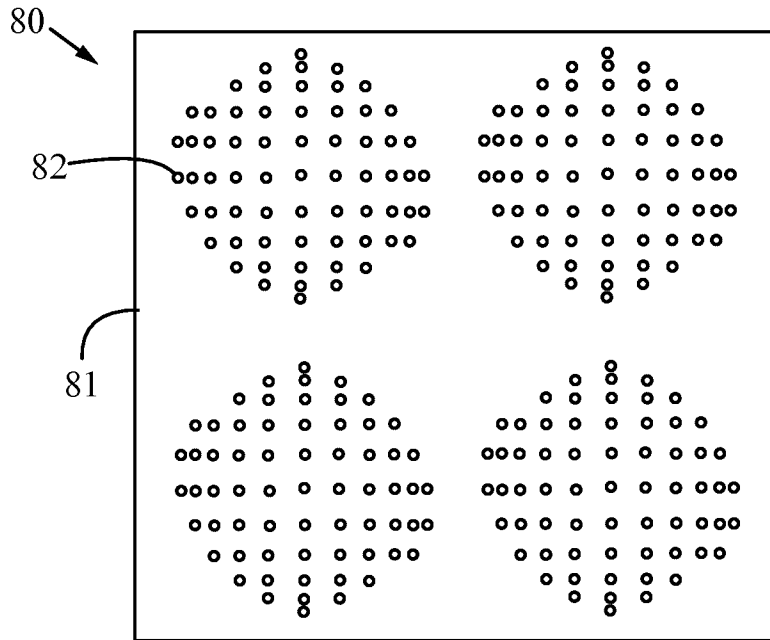

FIG. 23

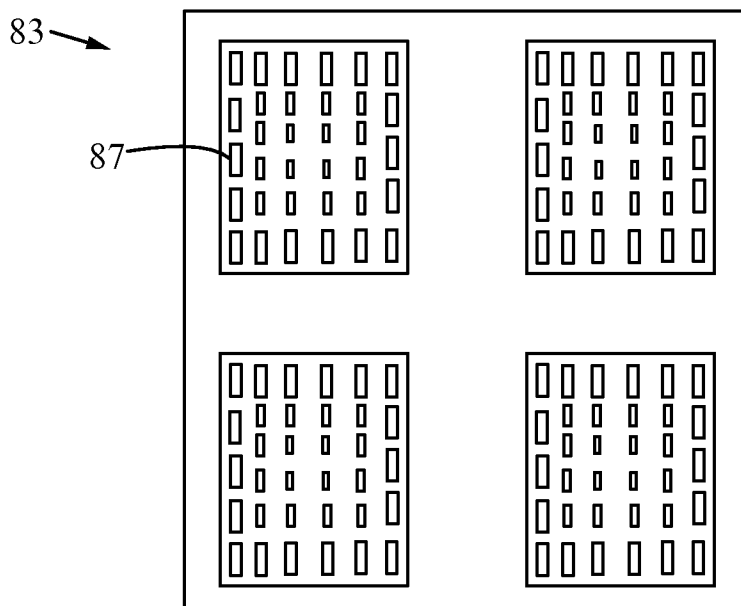

FIG. 24

23/31

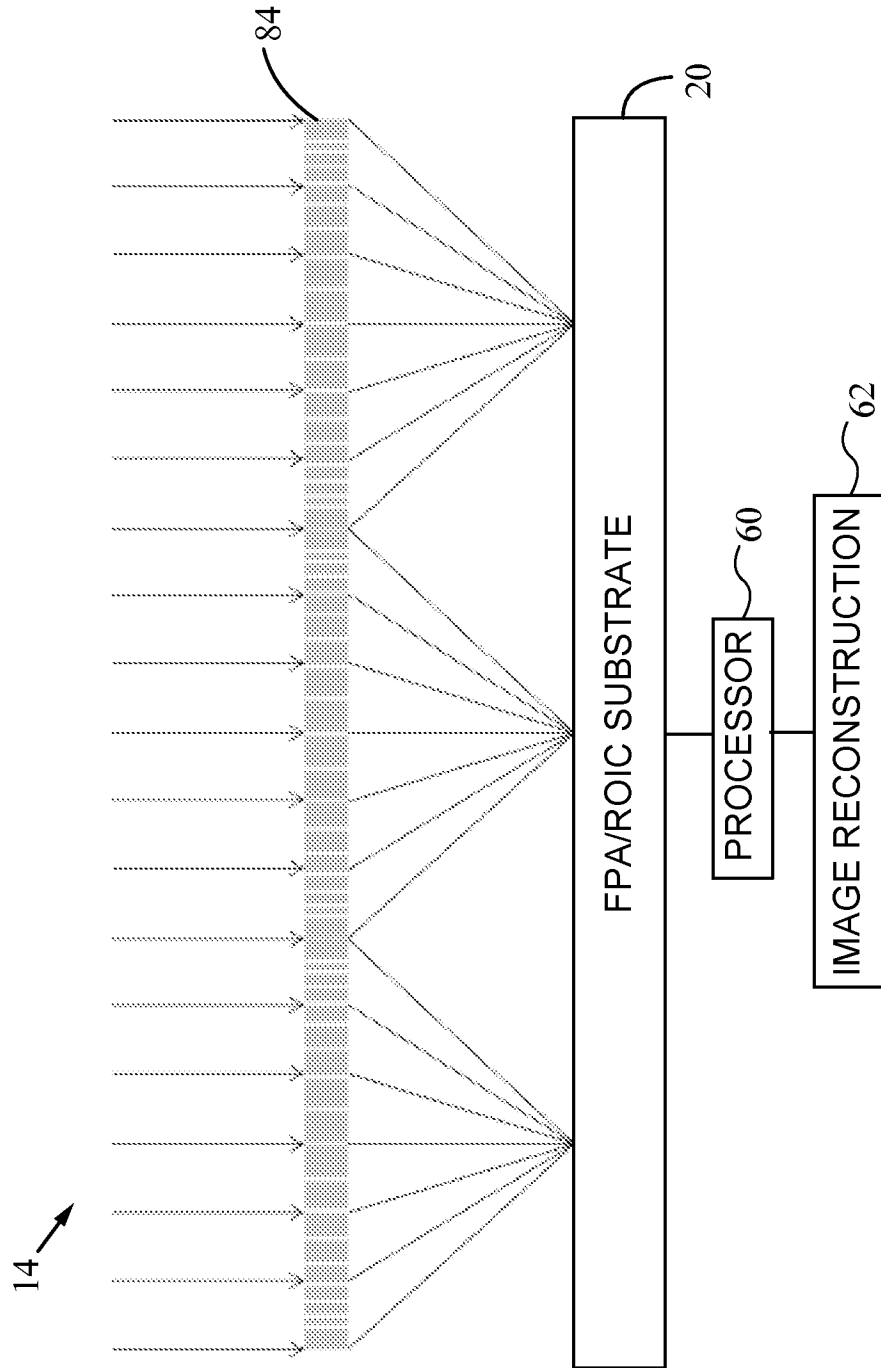

FIG. 25

24/31

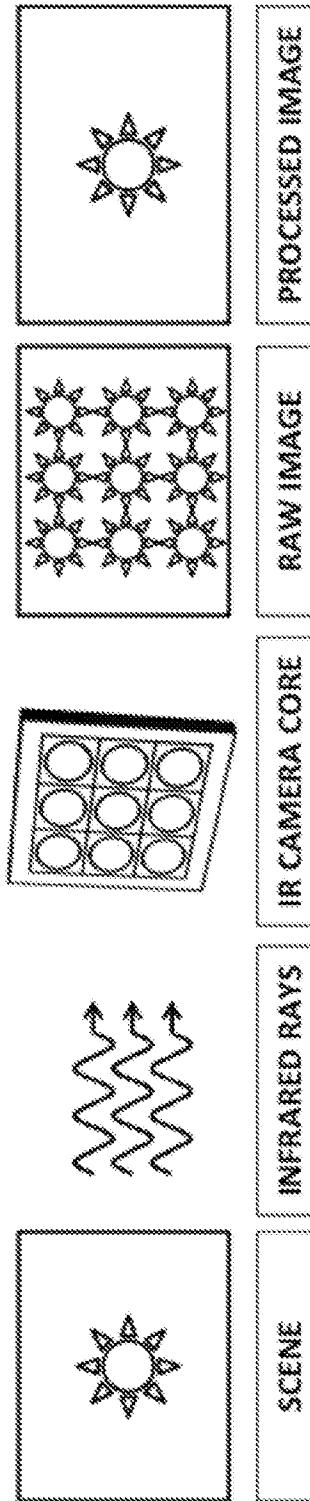

FIG. 26

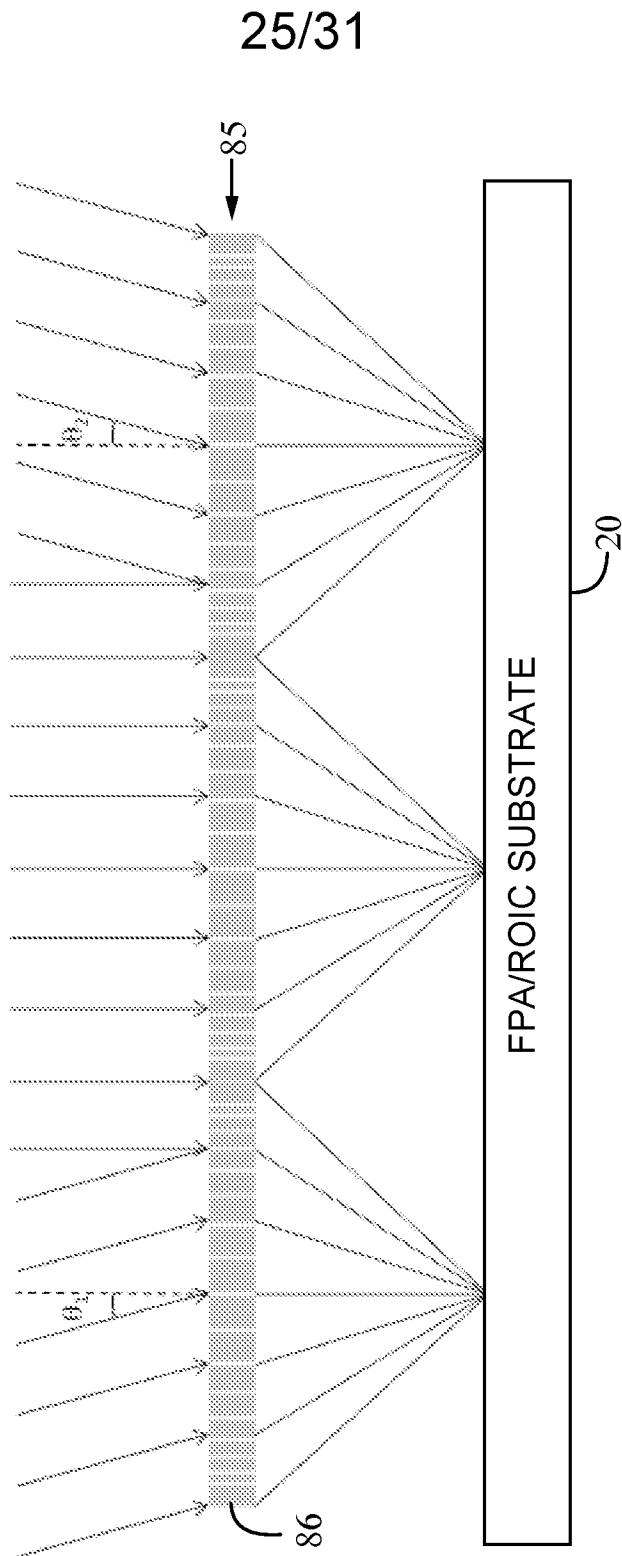

FIG. 27

26/31

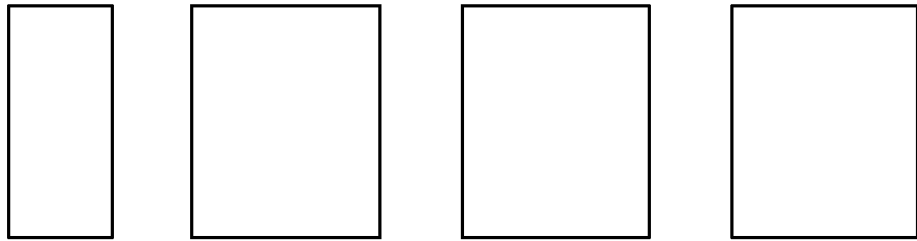

FIG. 28

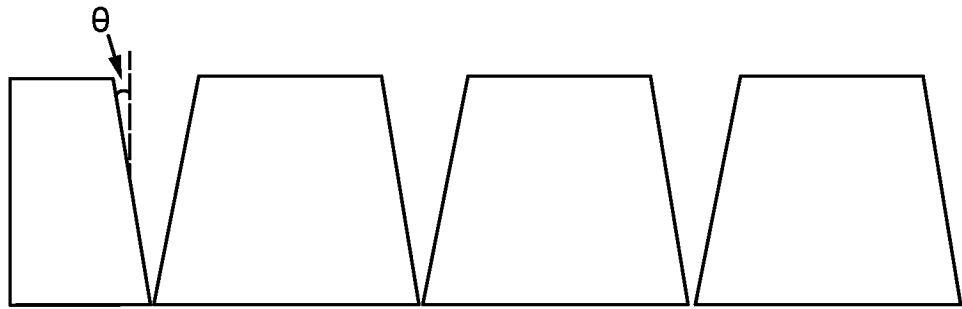

FIG. 29

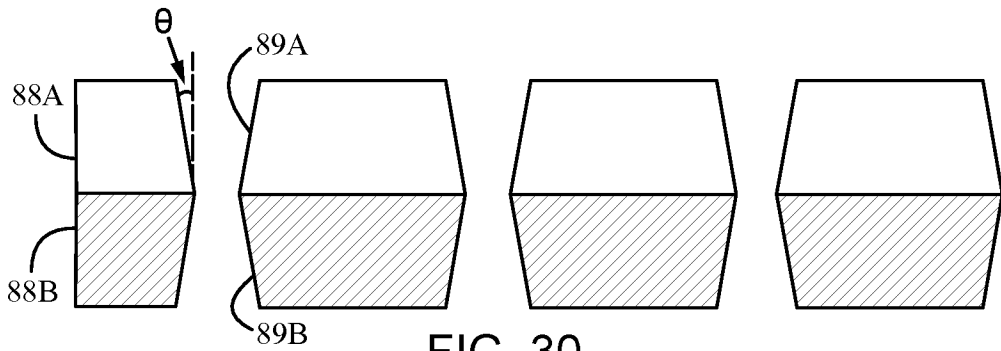

FIG. 30

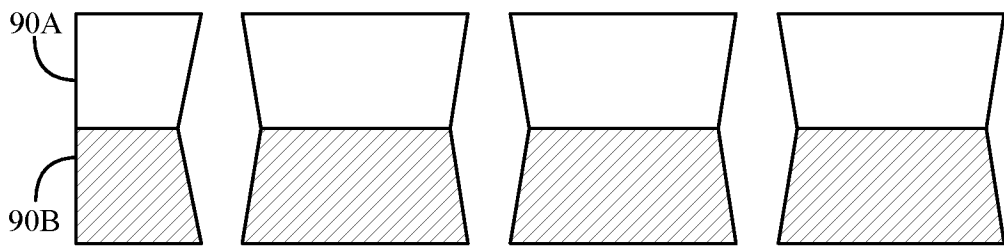

FIG. 31

27/31

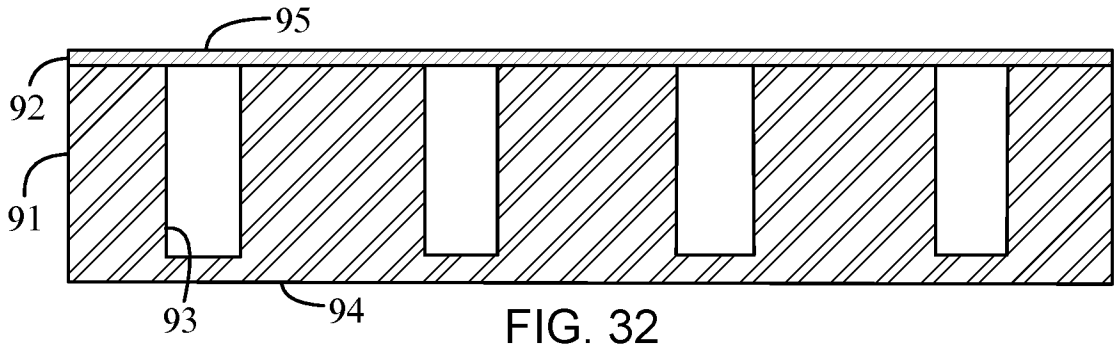

FIG. 32

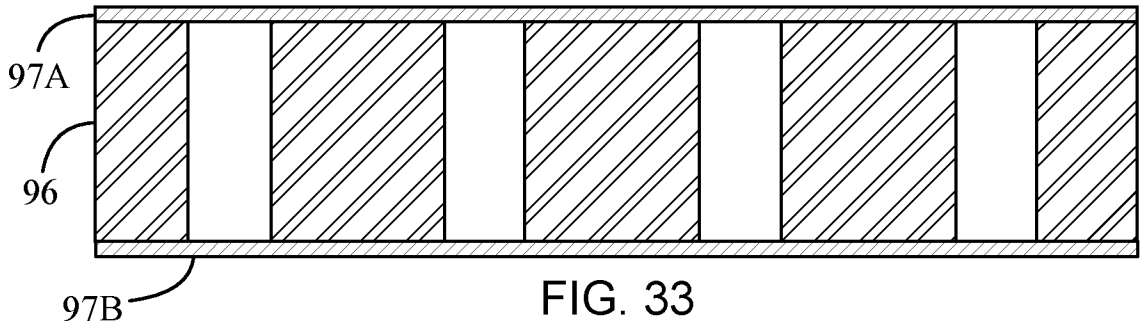

FIG. 33

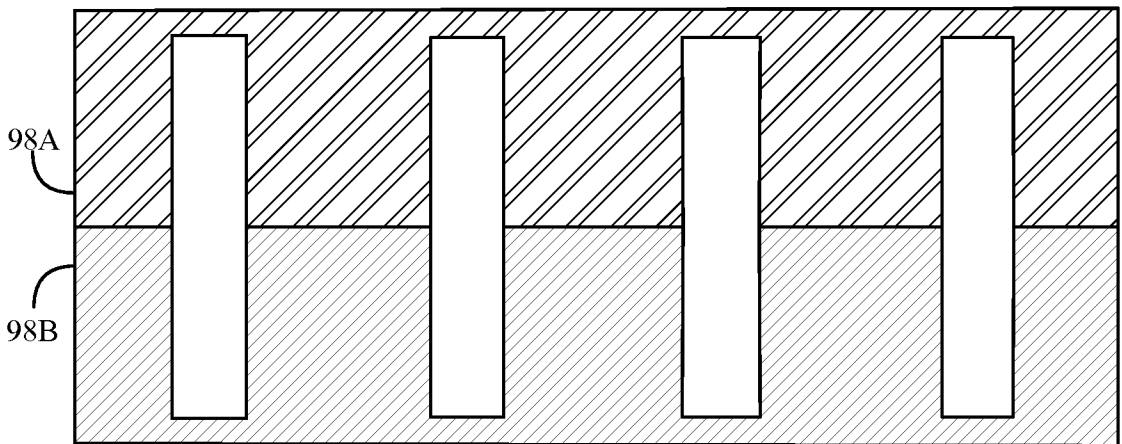

FIG. 34

28/31

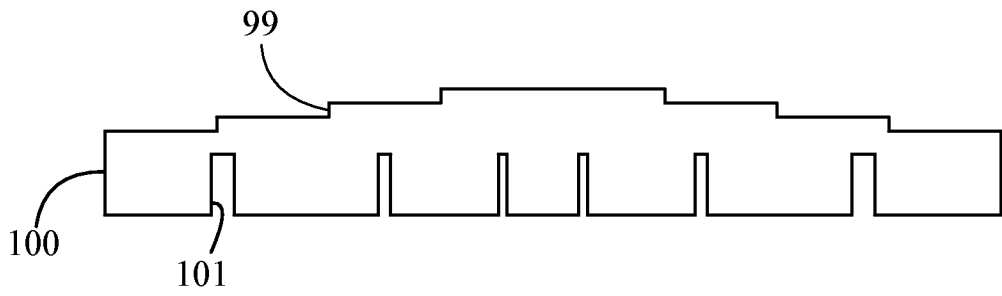

FIG. 35

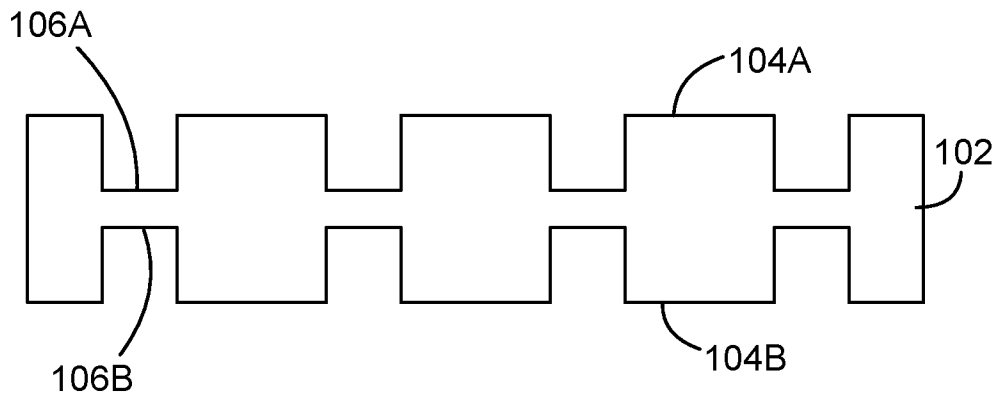

FIG. 36

29/31

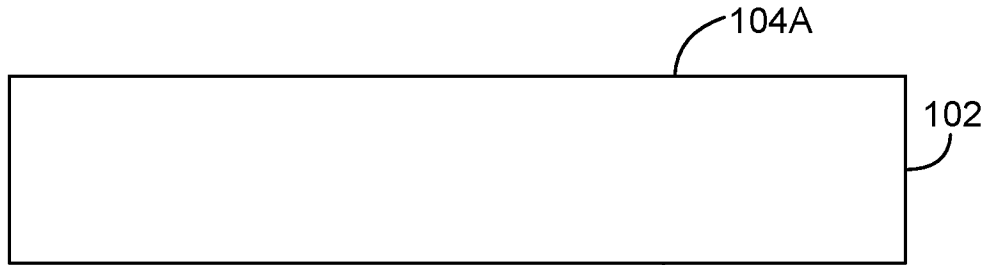

FIG. 37A

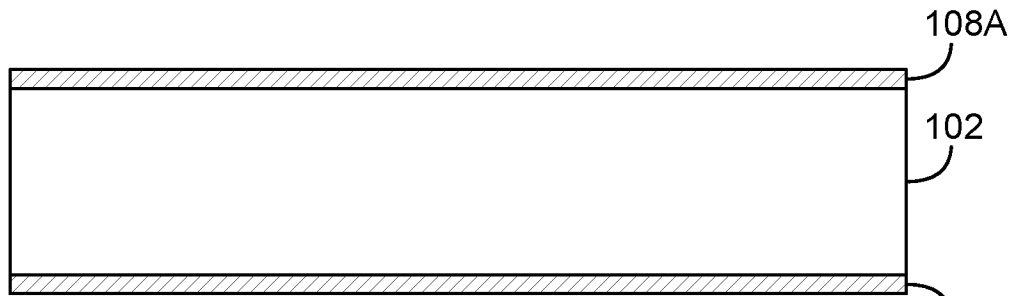

FIG. 37B

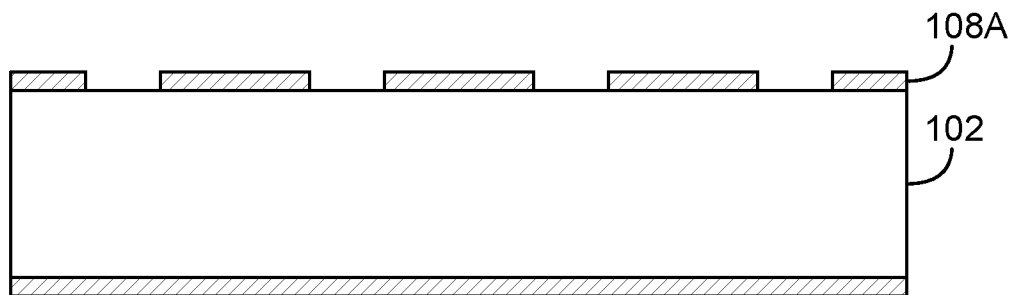

FIG. 37C

30/31

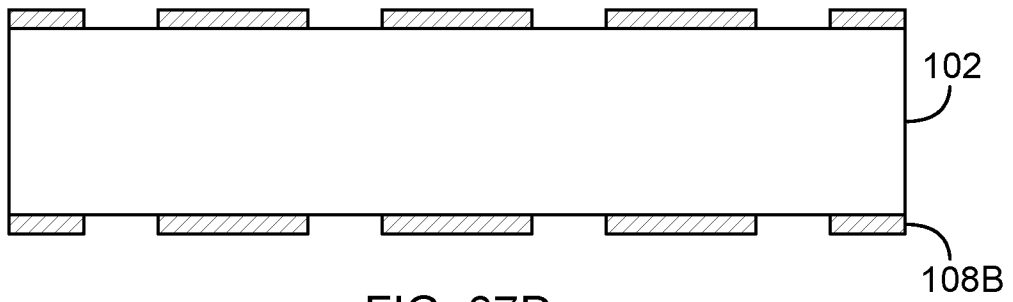

FIG. 37D

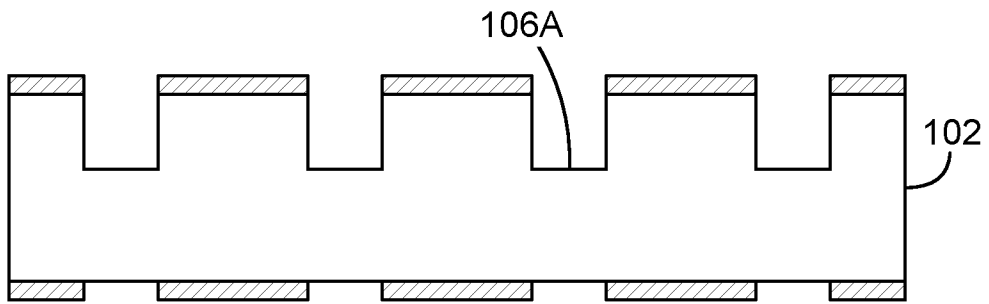

FIG. 37E

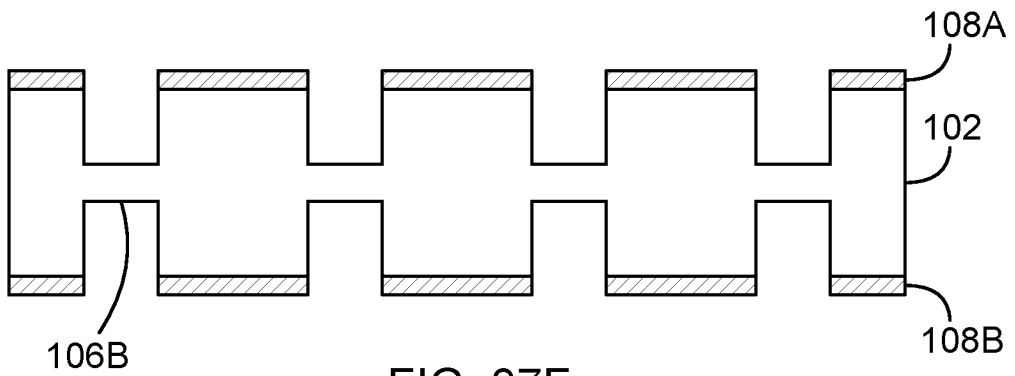

FIG. 37F

31/31

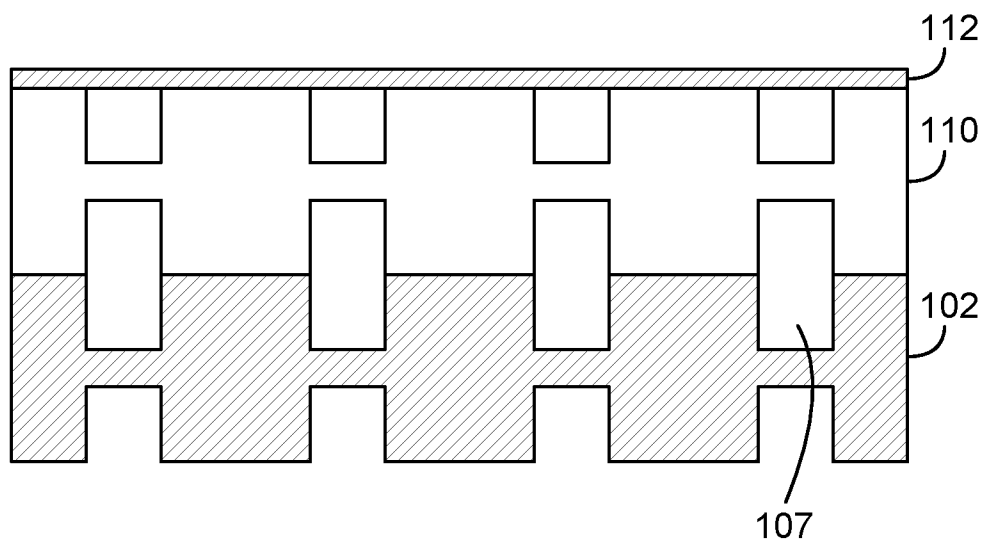

FIG. 38