

(12) PATENT
(19) AUSTRALIAN PATENT OFFICE

(11) Application No. AU 199888603 B2
(10) Patent No. 736237

(54) Title
Device for removably attaching a stretcher to a stretcher trolley

(51)⁷ International Patent Classification(s)
A61G 001/06 A61G 003/08

(21) Application No: **199888603** (22) Application Date: **1998.07.10**

(87) WIPO No: **WO99/03438**

(30) Priority Data

(31) Number	(32) Date	(33) Country
19730189	1997.07.15	DE

(43) Publication Date : **1999.02.10**

(43) Publication Journal Date : **1999.04.01**

(44) Accepted Journal Date : **2001.07.26**

(71) Applicant(s)
Ferno Washington, Inc.

(72) Inventor(s)
Rolf Steinmetz; Peter Josef Schlangen

(74) Agent/Attorney
SPRUSON and FERGUSON,GPO Box 3898,SYDNEY NSW 2001

(56) Related Art
EP 821927
US 4037871
US 5092722



<p>(51) Internationale Patentklassifikation ⁶ : A61G 1/06, 3/08</p>	<p>A1</p>	<p>(11) Internationale Veröffentlichungsnummer: WO 99/03438 (43) Internationales Veröffentlichungsdatum: 28. Januar 1999 (28.01.99)</p>
<p>(21) Internationales Aktenzeichen: PCT/EP98/04298 (22) Internationales Anmeldedatum: 10. Juli 1998 (10.07.98) (30) Prioritätsdaten: 197 30 189.4 15. Juli 1997 (15.07.97) DE (71) Anmelder (für alle Bestimmungsstaaten ausser US): FERNO WASHINGTON, INC. [US/US]; 70 Weil Way, Wilmington, OH 45177 (US). (72) Erfinder; und (75) Erfinder/Anmelder (nur für US): STEINMETZ, Rolf [DE/DE]; Georgstrasse 9, D-51145 Köln (DE). SCHLANGEN, Peter, Josef [DE/DE]; Christianstrasse 57, D-50259 Pulheim (DE). (74) Anwalt: WANISCHECK-BERGMANN, Axel; Köhne & Wanischek-Bergmann, Rondorfer Strasse 5a, D-50968 Köln (DE).</p>	<p>(81) Bestimmungsstaaten: AU, CA, JP, US, europäisches Patent (AT, BE, CH, CY, DE, DK, ES, FI, FR, GB, GR, IE, IT, LU, MC, NL, PT, SE). Veröffentlicht Mit internationalem Recherchenbericht. Vor Ablauf der für Änderungen der Ansprüche zugelassenen Frist; Veröffentlichung wird wiederholt falls Änderungen eintreffen.</p>	

(54) Title: DEVICE FOR REMOVABLY ATTACHING A STRETCHER TO A STRETCHER TROLLEY

(54) Bezeichnung: VORRICHTUNG ZUR LÖSBAREN VERBINDUNG EINER KRANKENTRAGE AUF EINEM KRANKENTRAGENFAHRGESTELL

(57) Abstract

The invention relates to a device for removably attaching a stretcher (1) to a stretcher trolley (8), comprising at least one but preferably two connecting elements (16) arranged on the stretcher trolley (8) and at least a corresponding number of locking elements (7) arranged on the stretcher (1) which are configured such that they correspond with the connecting elements (16) on the stretcher trolley (8). To improve on such a device in such a way that especially in case of accidents it offers greater safety in an ambulance, the invention provides for the locking elements (7) to be able to lock into the connecting elements (16) automatically and under pressure and for it to be possible to manipulate the connection between the locking elements (7) and the connecting elements (16) so as to detach said elements from each other.

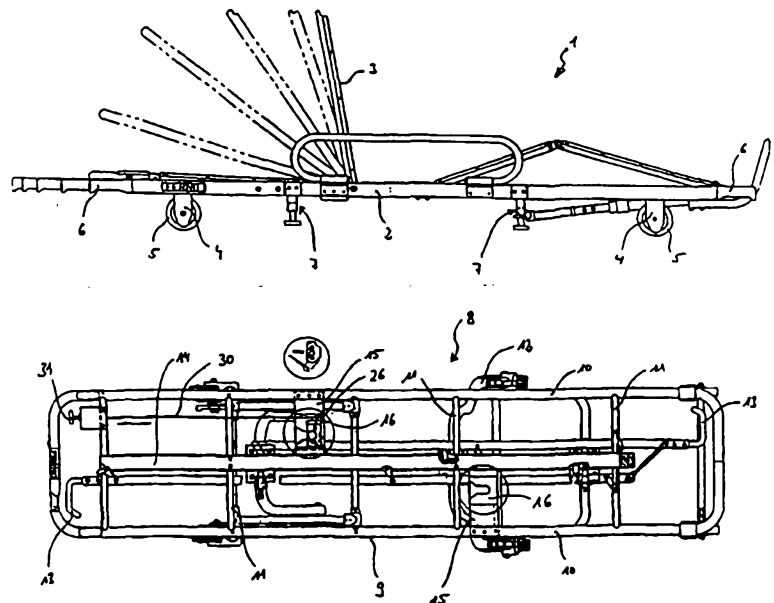

(57) Zusammenfassung

Die Erfindung betrifft eine Vorrichtung zur lösbaren Verbindung einer Krankentrage (1) auf einem Krankentragenfahrzeug (8) mit zumindest einem, vorzugsweise zwei am Krankentragenfahrzeug (8) angeordneten Verbindungselementen (16) und mit in zumindest entsprechender Anzahl an der Krankentrage (1) angeordneten, mit den Verbindungselementen (16) am Krankentragenfahrzeug (8) korrespondierend ausgebildeten Rastelementen (7). Um eine solche Vorrichtung derart weiterzuentwickeln, daß insbesondere bei Unfällen eine erhöhte Sicherheit in einem Krankentransportfahrzeug bereitgestellt wird, ist vorgesehen, daß die Rastelemente (7) in die Verbindungselemente (16) automatisch und auf Druck selbsttätig einrastbar sind und daß die Verrastung zwischen den Rastelementen (7) und den Verbindungselementen (16) zur Lösung der Verrastung manipulierbar ist.

**DEVICE FOR REMOVABLY ATTACHING A STRETCHER TO A
STRETCHER TROLLEY**

This invention relates to a device for removably attaching a stretcher to a stretcher trolley, comprising at least one but preferably two connecting elements arranged on the stretcher trolley and at least a corresponding number of locking elements arranged on the stretcher which are configured such that they correspond with the connecting elements on the stretcher trolley.

At the transport of stretchers in ambulance cars it is the usual practice that the stretchers are pushed into the ambulance car together with a stretcher trolley and that the stretcher trolley is locked in the ambulance car. As a rule, the stretcher is configured in such a manner that it is arranged in the stretcher trolley in a form-fit fashion. This configuration turned out to be advantageous to the effect that the stretcher can be quickly and easily lifted off the stretcher trolley at the site of use in order to serve for accommodating a patient to be rescued at an accident. After having the patient to be rescued bedded down on the stretcher, the stretcher is put onto the stretcher trolley which together with the stretcher is then pushed into the ambulance car, said trolley being transferred as a rule from an unfolded to a folded position and interlocked with the ambulance car or with locking devices provided in the ambulance car.

This prior art construction includes the drawback that the stretcher is merely placed onto the stretcher trolley. So if the ambulance car is involved in accident or even if bends of road are passed at a very high speed, there will be a considerable risk for the stretcher to come off the trolley, thereby seriously injuring passengers, i.e. the doctor on emergency call



and/or the rescue team. This danger particularly occurs when the ambulance car is involved in an accident.

It is therefore desirable to provide a device of the type concerned, by which the safety in an ambulance car is increased particularly in the case of accidents.

It is the object of the present invention to substantially overcome or at least ameliorate one or more of the disadvantages of the prior art.

Accordingly, the present invention provides a device for removably attaching a stretcher to a stretcher trolley, comprising at least one connecting element arranged on the stretcher trolley and a locking element corresponding to each connecting element arranged on the stretcher, wherein the locking elements, when pressed into the connecting elements, are detachably lockable into the connecting elements and wherein each connecting element is configured as a profile element which is substantially rectangular in cross-section having narrow faces arranged to extend substantially at right angles to a side which is provided with a slot having an open end for receiving the locking element.

In a preferred embodiment, it is possible to fix the patient fully and safely, particularly in connection with locking the stretcher trolley in the ambulance vehicle, so that any uncontrolled movement of the stretcher with the patient bedded down on it or of the stretcher alone is avoided particularly in the case where the ambulance car is involved in an accident. Due to the locking which is adapted to be manipulated, a preferred embodiment of the device can be operated in such a way that the good properties of a combined stretcher and stretcher trolley are maintained at the site of the accident, namely to the effect that the stretcher can be detached from the stretcher trolley very quickly.



In a preferred embodiment, said slot has at a closed end thereof a hook member which can be detachably connected to the locking element and which can be pivoted about an axis extending substantially parallel to the surface normal of the side interconnecting the narrow faces. Accordingly, this construction provides for the locking element to be inserted in a slot of the connecting element. On the end of the slot a hook member is provided which is operated by the locking element in such a manner that when the locking element strikes the hook member the latter will lock the locking element within the connecting element. The hook member of the connecting element can be disengaged by means of a simple Bowden control, so that upon operation of the Bowden control or a different disengaging device the locking element can be pulled out of the connecting element.

In a preferred embodiment, the slot is configured in such a manner that it widens towards its open end in a V-shape. This configuration has the advantage that the insertion of the locking element in the connecting element is made much easier and that the locking element is guided within said V-shaped widening slot to the correct position at the end of the slot.

In a preferred embodiment, the hook member is configured as a spring-loaded click adapted for pivoting about the axis and connected to a disengaging member. This configuration particularly serves to simplify the handling and the construction of the device. In this connection a further feature of the invention provides for the disengaging member to have a handle which protrudes towards the external side of the profile element. This handle can be operated either directly or via a power transmission element such as a Bowden control, rods or the like.

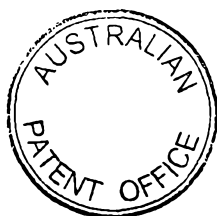

In a preferred embodiment, the disengaging member is movable in the transverse direction of the profile element, said disengaging member preferably being guided in a bore of the profile element.

5 In a preferred embodiment, between the disengaging member and the profile element a pre-stressed tension spring is arranged which attends to it that the disengaging member connected to the click automatically moves said click to a locking position. The click leaves said locking position only in that movement in which the locking element strikes an inclined surface of the click arranged towards the slot opening and in which the
10 click is, due to the inclination of this surface, urged out of the locking position. Immediately after the locking element has been fully moved past the inclined surface of the click, the tension spring will pull the click in its locking position, the force of the tension spring being transmitted to the disengaging member which is connected to the click in a form-fit fashion.

15 The locking elements are preferably fixed to a frame on the underside of the stretcher. It is further preferable that the locking elements each have a base body adapted to be fixed to the stretcher. The locking elements may also be adjustable relative to the base bodies.

20 In a preferred embodiment, the locking elements are comprised of a threaded rod portion and a plate which is preferably circular and which is fixed, if necessary under the interposition of a bar-shaped member, to the threaded rod or the threaded rod portion, the outer dimensions and particularly the diameter of the plate being larger than the diameter of the bar-shaped member and/or the threaded rod or threaded rod portion and the width of the slot in the region of the hook member.

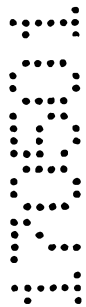
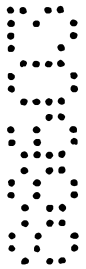

Preferably, the threaded rod or the threaded rod portion can be screwed into a threaded bore in the base body, so that the locking element is adjustable with regard to a precise position relative to the connecting element.

5 In a preferred embodiment, for a later mounting of the device to already existing stretchers it is advantageous for the base body to be comprised of two halves which can be connected and preferably screwed to each other, said halves encompassing a structural component of the stretcher.

10 In a preferred embodiment, it is advantageous to have two locking elements and two connecting elements respectively arranged diametrically opposite on the stretcher and the stretcher trolley, so that a connection between the stretcher and the stretcher trolley is obtained which lasts also in the case of accidents. The diagonal arrangement of the connecting and locking elements additionally offers the advantage that, if two locking
15 elements and two connecting elements are used, the connection between the stretcher and the stretcher trolley can be quickly established without requiring laborious joining work which would adversely affect rapid handling of this rescue device.

A preferred form of the present invention will now be described by way of example with reference to the accompanying drawings, wherein:

Figure 1 a lateral view of a stretcher;

20 Figure 2 a top view of the stretcher trolley;

Figure 3 a lateral view of a locking element with a connecting element;

Figure 4 the locking element according to Figure 3, in a lateral view;

Figure 5 the locking element according to Figure 4, in a plan view; and

Figure 6 a top view of the connecting element.



In Figure 1 a stretcher 1 is shown which is comprised of a frame 2 and of a patient support 3 which is arranged on the frame 2 and is adjustable in multiple positions. The frame 2 is formed by two mutually parallel tubular side members and two tubular cross member which interconnect said side members. On the side members there are arranged on the underside of the frame 2 U-shaped supporting brackets 4 with wheels 5 supported therein for rotation. In addition, the side members have on the ends thereof handles 6 which are guided to telescope within the tubular side members of the frame 2. Between two supporting brackets 4, which are arranged on a side member of the frame 2, two locking elements 7 are fixed to the fame 2 of the stretcher 1. These locking elements 7 will be further elucidated in the following.

5

10



Figure 2 shows a stretcher trolley 8 in a top view. The stretcher trolley 8 likewise consists of a frame 9 which includes two side members 10 and plural cross members 11 interconnecting said side members 10.

To the frame 9 a foldable chassis 12 known per se is fixed. This chassis 12 can be locked in an unfolded position. For the transport of the chassis 12 with the stretcher 1 arranged thereon in an ambulance car (not shown) the chassis 12 is pivotally moved from its unfolded to its folded position in which the chassis 12 substantially directly rests against the side members 10 or the cross members 11 of the frame 9 of the stretcher trolley 8. For disengaging the locking elements which hold the chassis in its unfolded position handles 13 are provided on both narrow faces of the stretcher trolley 8, which handles are connected to the locking elements of the chassis 12 through rods.

The stretcher trolley 8 includes between the side members 10 a base plate 14 which substantially extends over the whole length of the frame 9 of the stretcher trolley 8. The base plate 14 takes its support on the cross members 11 and is fixed thereto by means of screws or rivets.

Between the base plate 14 and a respective side member 10 two diametrically opposite plates 15 are arranged which are fixed to a side member 10 on one part and to the base plate 14 on the other part, by means of screws or rivets. Each plate 15 carries a connecting element 16 which is still further elucidated in the following and which is provided for the detachable connection to a locking element 7 of the stretcher 1, so that the stretcher 1 is connected to the stretcher trolley 8 in a form-fit fashion.



An embodiment of the connecting element 16 is shown in Figure 6. The connecting element 16 is comprised of a rectangular profile element 17 which includes two mutually parallel plates 18 and 19 arranged with a distance to each other and interconnected through narrow faces 20. The profile element 17 has in its plate 19 a slot 21 which is open on one side and which widens towards its open end in a V-shape.

This slot 21 serves for receiving the locking element 7 and includes in the region of its closed end a hook member 22 which is detachably connectable to the locking element 7, of which only a cylindrical portion 23 is shown in Figure 6. The hook member 22 is connected to a tongue 24 which can be pivoted about an axis 25 on the profile element 17. On the end of the tongue opposite the axis 25 said tongue 24 is fixed to a disengaging member 26 which is in the form of an L-shaped shaft which penetrates through one narrow side 20 of the profile element 17 and which has a handle 27 on its end protruding from the profile element 17.

By means of the handle 27 the disengaging member 26 is supported within the profile element 17 so as to be movable therein against the force of a spring 29 in the direction of arrow 28.

When the portion 23 of the locking element 7 is pushed into the slot 21 of the profile element, the locking element 7 will lock behind the hook member of the profile element 17. Now the locking element 7 cannot be disengaged any longer from the connecting element 16, unless the disengaging member 26 is actuated. Only the operation of the handle 27 and the movement of the hook member 22 connected thereto will disengage the locking element 7, i.e. the portion 23, so that the locking element 7 can be pulled out of the slot 21. The embodiment of the connecting element 16



shown in Figure 2 is different from the embodiment of the connecting element 16 shown in Figure 6 by that the disengaging member 26 is connected to a pull 31 through a rope or Bowden control 30. The pull 31 is arranged on one end of the frame 9 of the stretcher trolley 8.

Here it can be provided for the manipulation or control of both connecting elements 16 by means of a common pull 31, so that both connecting elements 16 can be disengaged at the same time. The locking element 7 shown in Figures 4 and 5, which can be fixed to the frame 2 of the stretcher 1, has a base body 32 which in this construction example consists of a profile piece 33 substantially having a U-shaped cross-section and provided with lateral flanges 34, each of the flanges having a bore 35 for receiving fixing bolts (not shown). The flanges 34 are arranged collinear on the free ends of the U-shaped profile piece 33. Between the flanges 34 a log-shaped element 36, which is substantially rectangular in cross-section and trapezoidal in the longitudinal section, is fixed to the base body 32. In this element 36, which consists of solid material, a threaded bore 37 is provided which extends at right angles to the longitudinal axis of the U-shaped profile piece 33. Into this threaded bore 37 a threaded rod portion 38 is screwed which coaxially verges into the portion 23, on the free end of which a screw head 39 with a slot 40 is provided. The diameter of the screw head 39 is larger than the diameter of the portion 23. Furthermore, the diameter of the screw head 39 is larger than the clear width of the slot 21 following the V-shaped widening of the free end of this slot 21.

It can be seen from the Figures 4 and 5 that a counter part 41 is screwed on the threaded rod portion 38. In this locking element 7 the threaded rod portion 38, the element 23 and the screw head 39 can be adjusted relative to the base body 32. In order to fix the threaded rod portion 38, the ele-



ment 23 and the screw head 39 after they have been adjusted relative to the element 36, the counter part 41 must be screwed up against the element 36. The adjustability of the portion 23 relative to the element 36 is shown in Figure 6 by way of the double arrow 42.



The claims defining the invention are as follows:

1. A device for removably attaching a stretcher to a stretcher trolley, comprising at least one connecting element arranged on the stretcher trolley and a locking element corresponding to each connecting element arranged on the stretcher, wherein the locking elements, when pressed into the connecting elements, are detachably lockable into the connecting elements and wherein each connecting element is configured as a profile element which is substantially rectangular in cross-section having narrow faces arranged to extend substantially at right angles to a side which is provided with a slot having an open end for receiving the locking element.

2. A device according to claim 1, wherein the slot has at a closed end thereof a hook member which is detachably connectable to the locking element and which is pivotable about an axis extending substantially parallel to the surface normal of said side interconnecting the narrow faces.

3. A device according to claim 2, wherein the slot is formed in such a manner as to widen towards its open end in a V-shape.

4. A device according to claim 2, wherein the hook member is configured as a spring-loaded click which can pivot about said axis and which is connected to a disengaging member.

5. A device according to claim 4, wherein the disengaging member includes a handle which protrudes towards the outside of the profile element.

6. A device according to claim 4 wherein the disengaging member is movable in the transversal direction of the profile element.

7. A device according to claim 6 wherein said disengaging member is guided within a bore of the profile element.

8. A device according to claim 4, wherein between the disengaging member and the profile element a pre-stressed tension spring is arranged.

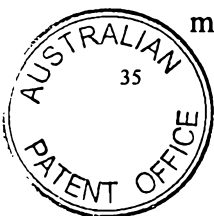

9. A device according to claim 1, wherein the locking elements are fixed to a frame on the underside of the stretcher.

5 10. A device according to claim 1, wherein the locking elements respectively have a base body which can be fixed to the stretcher.

11. A device according to claim 10, wherein the locking elements are adjustable relative to the base bodies.

10

12. A device according to any one of claims 1 to 11, wherein the locking elements are comprised of a threaded rod or a threaded rod portion and a plate which is fixed to the threaded rod or the threaded rod portion by a bar-shaped member, wherein the diameter of the plate is larger than the diameter of the bar shaped member and/or the threaded rod or threaded rod portion and the width of the slot in the region of the hook member.

15

13. A device according to claim 12, wherein said plate is circular.

20

14. A device according to claim 12 or 13, wherein the threaded rod or the threaded rod portion can be screwed into a threaded bore in the base body.

15. A device according to anyone of claims 12 to 14, wherein a counter part is screwed on the threaded rod or the threaded rod portion.

25

16. A device according to claim 11, wherein the base body consists of two halves which can be connected and, which encompass a structural component of the stretcher.

30

17. A device according to claim 16, wherein said two halves are screwed to each other.

18. A device according to any one of claims 1 to 17, wherein two locking elements and two connecting elements are respectively arranged diametrically opposite on the stretcher and the stretcher trolley.

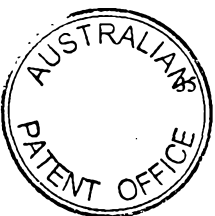
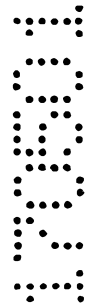
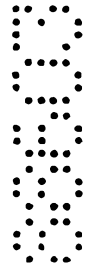

19. A device constructed arranged and adapted to operate substantially as hereinbefore described with reference to the accompanying drawings.

5

Dated 16 May, 2001
Ferno Washington, Inc.
Patent Attorneys for the Applicant/Nominated Person
SPRUSON & FERGUSON

5800

1000

