

No. 641,509.

Patented Jan. 16, 1900.

W. E. HASKELL.
VALVE.

(Application filed Aug. 19, 1899.)

(No Model.)

2 Sheets—Sheet 1.

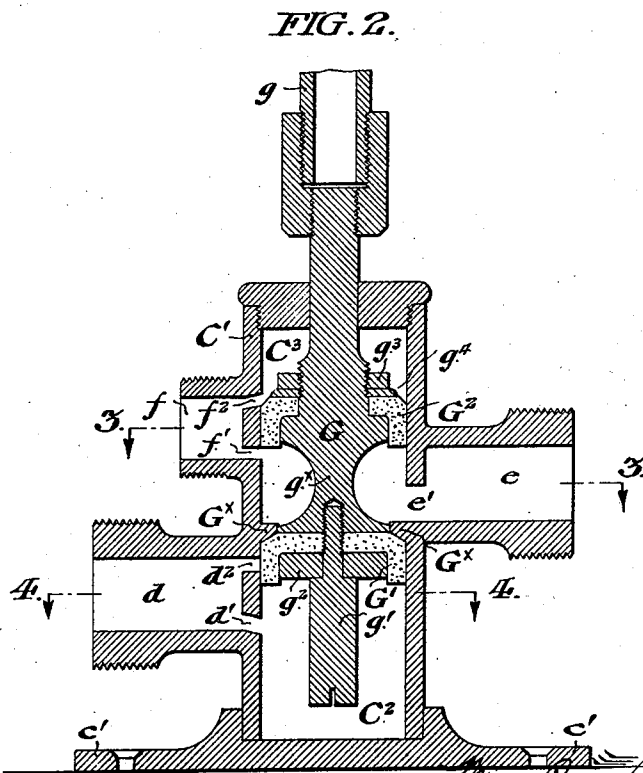
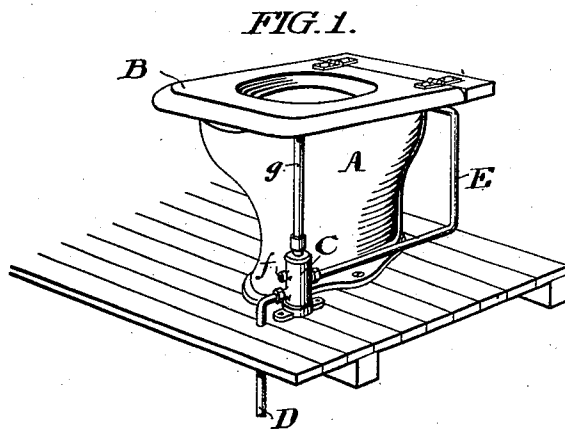

WITNESSES:

Arthur E. Paige
J. Norman Dixon

INVENTOR:

W. E. Haskell
by his attorney
W. C. Strawbridge

No. 641,509.

Patented Jan. 16, 1900.

W. E. HASKELL.
VALVE.

(Application filed Aug. 19, 1899.)

(No Model.)

2 Sheets—Sheet 2.

FIG. 4.

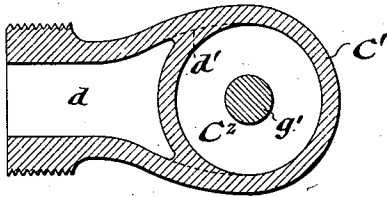

FIG. 3.

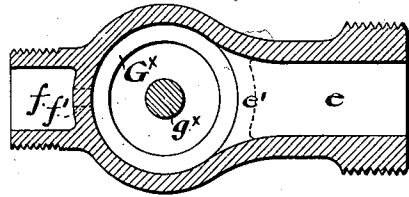
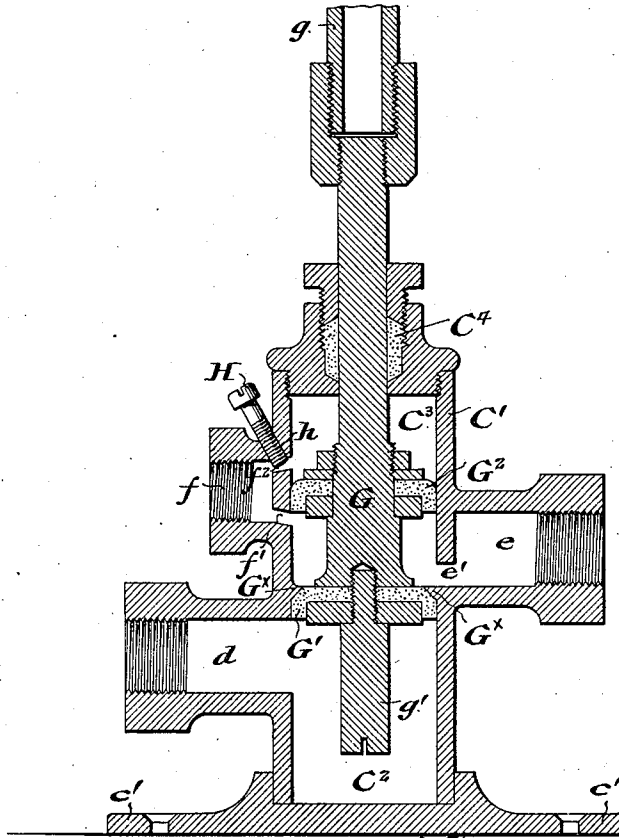

FIG. 5.



WITNESSES:
Arthur E. Paige
F. Norman Dixon

Wm. E. Haskell INVENTOR:
Levis attorney
Wm. C. Strawbridge

UNITED STATES PATENT OFFICE.

WILLIAM E. HASKELL, OF PHILADELPHIA, PENNSYLVANIA.

VALVE.

SPECIFICATION forming part of Letters Patent No. 641,509, dated January 16, 1900.

Application filed August 19, 1899. Serial No. 727,767. (No model.)

To all whom it may concern:

Be it known that I, WILLIAM E. HASKELL, of Philadelphia, in the State of Pennsylvania, have invented certain new and useful Improvements in Valves, whereof the following is a specification, reference being had to the accompanying drawings.

My invention relates to a valve adapted to automatically permit the flow of water to a water closet hopper during the use of the latter, and, in its preferred embodiment, my improved valve is arranged to be opened by depression of the seat connected with the closet hopper to be supplied with water, and closed by the water pressure, within the valve, upon release of said seat.

In the accompanying drawings, Fig. 1, is a perspective view of the hopper and seat, with a convenient embodiment of my invention applied thereto.

Fig. 2, is a vertical sectional view of the valve shown in Fig. 1.

Figs. 3, and 4, are plan sectional views of said valve taken respectively on the lines 3, 3, and 4, 4, of Fig. 2.

Fig. 5, is a vertical sectional view of a modified form of said valve.

In said figures, A, is the hopper, provided with the hinged seat B; and C, is the valve arranged to control the flow of water from the water service pipe D, through the delivery pipe E, to the hopper.

The outer casing C', of the valve C, has a foot flange c', for connection to its supporting structure, and is provided with an inlet d, for connection with the service pipe D, an outlet e, for connection with the delivery pipe E, and a waste outlet f, which may remain open as shown, or be connected to the drain or sewer, as desired.

Within the valve casing C', the plunger G, is mounted for vertical reciprocation and, the plunger stem g, is suitably extended to contact with the underside of the hinged seat B, and raise the latter as indicated in Fig. 1, when said plunger G, is in the position shown in Fig. 2. The plunger G, is provided with two heads G', G²; the head G', being arranged to control communication between the inlet d, and the outlet e, and the head G², being arranged to control the communication between

the supply outlet e, and the waste-outlet f, to drain the pipe E, etc., and thus obviate the danger of water freezing therein, when the closet is not in use.

The relation of the valve parts is such that when the plunger is in the position shown in Fig. 2, the head G', is raised to contact with the seat G^x, by the pressure of water beneath said head in the chamber C²; the latter being in communication with the pipe D, through the port d'; and, the head G², is raised to permit the free exit of water from the pipe E, around the reduced portion g^x, of the plunger G, through the port f'.

Said heads G', and G², are conveniently formed of cup leathers; the head G', being secured in position by means of the stud screw g', entered through the washer g², in threaded engagement with the plunger G. Said screw g', also serves as a stop to limit the downward movement of the plunger G, by contact with the bottom of the chamber C². The head G², is secured in proper relation with said plunger G, by means of the nut g³, and washer g⁴, the former being in threaded engagement with the stem of the plunger G.

The operation of my device is as follows:—The seat B, being depressed; the plunger G, is shifted downward until the stud screw g', contacts with the bottom of the chamber C². In said position of the parts the head G', being below the port d', leading from the inlet d, the water supplied by the pipe D, is permitted to pass to the outlet e, and is delivered through the pipe E, to the hopper A. In said position of the parts any waste of the water through the outlet f, is prevented by the head G², which closes the port f'.

It is to be noted that the valve may be maintained open only by downward pressure upon the plunger G, by means of the seat B, or otherwise, the water pressure in the chamber C², beneath the head G', being at all times sufficient to uplift said plunger G, and seat B, and thus close the valve when relieved from said abnormal downward pressure. When so released the valve closes without shock or jar upon the seat G^x, for the reason that communication between the inlet d, and outlet e, is shut off by the cylindrical portion of the head G', before the latter contacts with

said seat G^x ; and, simultaneously therewith the port f^1 , is opened to permit drainage of the pipe E, etc.

As a result of this arrangement, as will be seen, before the head G' reaches its seat, it passes upward through that portion of the casing between the upper edge of the inlet d and the seat, making, of course, tight contact with the wall of the casing.

The water in said space above the head G' cannot pass down at the side of said head, but must be elevated by said head against the pressure or weight of the water in the casing below the outlet f . The water above the head G' , therefore, acts as a cushion to prevent shock in the contact of the head G' with its seat, the cushioning action being supplemented by the cushioning action of the air in the upper end of the casing above the head G^2 , in the construction shown in Fig. 5.

In the form of my invention above described, the amount of time required to effect the automatic closure of the valve when released from the downward pressure of the seat is determined by the difference in pressure above and below the heads G' , and G^2 , of the plunger G , the rate of closing of this form of my valve, is therefore practically constant, and predetermined by the proportion of the parts, however, I find it advantageous to provide means to adjustably regulate the rate of closing of the valve, and I have therefore illustrated in Fig. 5, a convenient embodiment of my invention, wherein the port f^2 , leading from the chamber C^3 , which serves as a dash pot for the plunger head G^2 , is provided with means to vary its effective area, conveniently a set-screw H, which is in threaded engagement with the casing C' , at h , and serves to obstruct said port f^2 , more or less in accordance with its position in said casing.

In the construction shown in said Figure 5 the stem is illustrated as provided with a stuffing box C^4 of usual construction and arrangement.

As will be understood, referring still to Figure 5, the air contained in the chamber C^3 , being unable to escape through the opening in the upper end of the casing through which the plunger stem extends, and only able to escape by a slow rate through the opening or port f^2 , will act as a cushion to slightly retard the ascent of the plunger under the pressure of the water beneath the lower head.

The device H controls the size of the opening or port f^2 with the result that while the structure as a whole can be made of standard size, the apparatus may by said device be regulated according to the varying water pressure in the different localities in which it may be employed.

In the construction shown in Figure 5 any water which may by accident find access to the chamber C^3 will, of course, run out through the outlet f^2 .

In the construction shown in Figure 2 no stuffing box is applied to the stem of the plun-

ger and the opening or port f^2 is shown as of quite large diameter.

In this construction the air will escape quite freely through the large opening f^2 and may also escape through the unpacked opening in the upper end of the casing through which the plunger stem extends.

Water obtaining entrance by accident to the chamber C^3 in the construction shown in said Figure 2 will by reason of the large size of the opening or port f^2 and its location at the lower edge of said chamber escape through said opening f^2 and will, therefore, not rise through the opening in the upper end of the casing through which the valve stem extends.

It is to be understood that the device H shown in Figure 5 as controlling the opening or port f^2 may be applied as the requirements of the trade may demand to any of the ports or openings of the apparatus.

It is to be noted that in both forms of my invention herein set forth, no springs or similar devices are employed to effect the automatic closure of the valve, but said closure is effected solely by the water pressure beneath the plunger G , and that when said plunger is in its closed position, the accidental passage of the water through the valve is not only prevented by the lateral pressure of the head G' , within the casing C' , but said head is also directly in contact with the seat G^x , in said casing.

It is obvious that various modifications may be made without departing from the essential features of my invention, and I therefore do not desire to limit myself to the precise arrangement and proportion of the parts which I have illustrated.

I claim—

1. In a valve, in combination, a closed casing having a water supply inlet, a delivery outlet port above said supply inlet, and a waste outlet formed as two independent openings or ports above the delivery outlet port, an annular valve or plunger seat formed in said casing between the supply inlet and the delivery outlet port, and a plunger provided with two heads mounted in said casing, arrangement being such that when the plunger is at the upper limit of its stroke the upper head is between the two openings of the waste outlet port and the lower head is in the annular seat, and when at the lower limit of its stroke the upper head closes the lower opening of the waste outlet and the lower head is below the upper portion of the water supply inlet, substantially as set forth.

2. In a valve, in combination, a closed casing having a water supply inlet, a delivery outlet above said supply inlet, and a waste outlet formed as two independent openings or ports above the delivery outlet, an annular valve or plunger seat formed in said casing between the supply inlet and the delivery outlet, a plunger provided with two heads mounted in said casing, the arrangement being such that when the plunger is at the up-

per limit of its stroke the upper head is between the two openings of the waste outlet and the lower head is in the annular seat, and when at the lower limit of its stroke the upper head closes the lower opening of the waste outlet and the lower head is below the upper portion of the water supply inlet, a stem connected to said plunger and extending through the top of the casing, and a stud depending from the plunger and adapted, by contact with the floor of the casing to limit the descent of the plunger, substantially as set forth.

3. In a valve, in combination, a vertically disposed casing having a bore of circular section, and embodying a water supply inlet, a delivery outlet above said supply inlet, and a waste outlet formed as two independent openings or ports above the delivery outlet, an annular seat formed in said casing between the supply inlet and the delivery outlet, and a plunger, provided with two heads, mounted in said casing, the arrangement being such that when the plunger is at the upper limit of its stroke the upper head is between the two openings of the waste outlet and the lower head is in the annular seat, and when at the lower limit of its stroke the upper head closes the lower opening of the waste outlet and the lower head is below the upper portion of the water supply inlet, each head of the plunger being provided with a cup leather the depending flanges of which are in contact with the wall of the casing, substantially as set forth.

4. In a valve, in combination, a closed casing having a water supply inlet formed as two independent openings or ports, a delivery outlet port above said supply inlet, and a waste outlet formed as two independent openings or ports above the delivery outlet port, an annular valve or plunger seat formed in said casing between the supply inlet and the delivery outlet port, a plunger provided with two heads, mounted in said casing, the arrangement being such that when the plunger is at the upper limit of its stroke the upper head is between the two openings of the waste outlet and the lower head is in the annular seat, and when at the lower limit of its stroke the upper head closes the lower opening of the waste outlet and the lower head is between the two openings of the water supply inlet, substantially as set forth.

5. In a valve, in combination, a closed casing having a water supply inlet formed as two independent openings or ports, a delivery outlet port above said supply inlet, and a waste outlet formed as two independent openings or ports above the delivery outlet port, an annular valve or plunger seat formed in said casing between the supply inlet and the delivery outlet port, a plunger provided with two heads, mounted in said casing, and cup leathers mounted one on each head, each hav-

ing its depending flange in constant contact with the wall of the casing, the arrangement being such that when the plunger is at the upper limit of its stroke the upper head is between the two openings of the waste outlet and the lower head is in the annular seat, and when at the lower limit of its stroke the upper head closes the lower opening of the waste outlet and the lower head is between the two openings of the water supply inlet, substantially as set forth.

6. In a valve, in combination, a casing having a water supply inlet formed as two independent openings, a delivery outlet port above said supply inlet, and a waste outlet formed as two independent openings or ports above the delivery outlet port, an annular seat formed in said casing between the supply inlet and the delivery outlet port, a plunger provided with two heads, mounted in said casing, the arrangement being such that when the plunger is at the upper limit of its stroke the upper head is between the two openings of the waste outlet port and the lower head is in the annular seat, and when at the lower limit of its stroke the upper head closes the lower opening of the waste outlet and the lower head is below the upper portion of the water supply inlet, a stem connected to said plunger and extending through the top of the casing, and a stud depending from the plunger and adapted by contact with the floor of the casing to limit the descent of the plunger, substantially as set forth.

7. In a valve, in combination, a casing formed as a cylindrical structure having a water inlet formed as two independent ports or openings, a delivery outlet above said openings, and a waste outlet formed as two independent ports or openings above said delivery outlet the apertures of said inlet and outlets opening through the cylindrical inner face of the casing, which inner face is, except for the plunger seat, of uninterrupted cylindrical contour, an annular plunger seat formed on the inner face of said casing between the water supply inlet and the delivery outlet, a plunger mounted in said casing and having two heads united by a connecting portion of reduced diameter, each head of such diametric proportions as to snugly and closely fit the bore or cylindrical interior of the casing, and the lower head being adapted to the plunger seat referred to, substantially as set forth.

In testimony that I claim the foregoing as my invention I have hereunto signed my name this 12th day of August, A. D. 1899.

WILLIAM E. HASKELL.

In presence of—

EDWD. C. REGN,
E. L. FULLERTON.