

(No Model.)

E. BOCKMAN & J. E. HAGAN.
FENDER FOR TROLLEY OR OTHER CARS.

No. 524,883.

Patented Aug. 21, 1894.

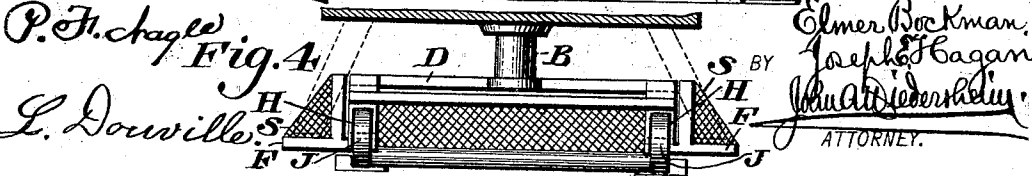
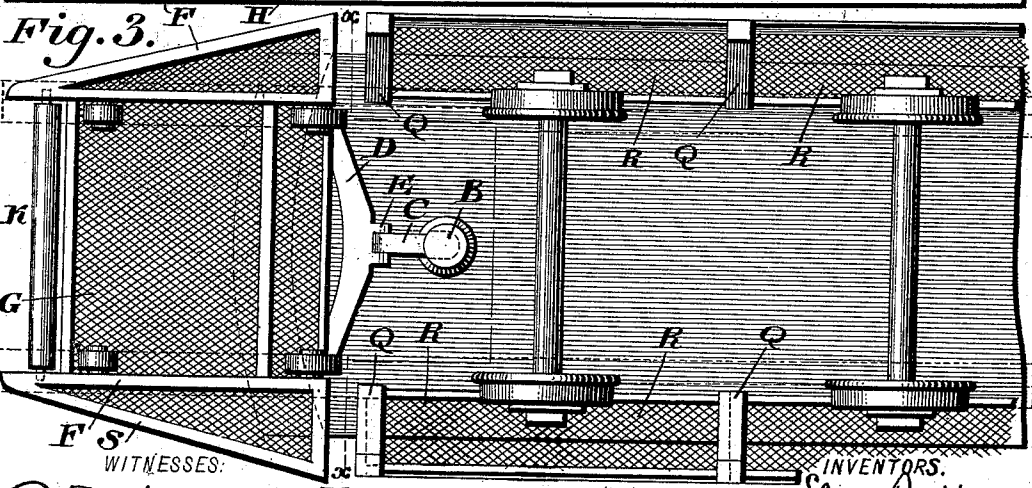
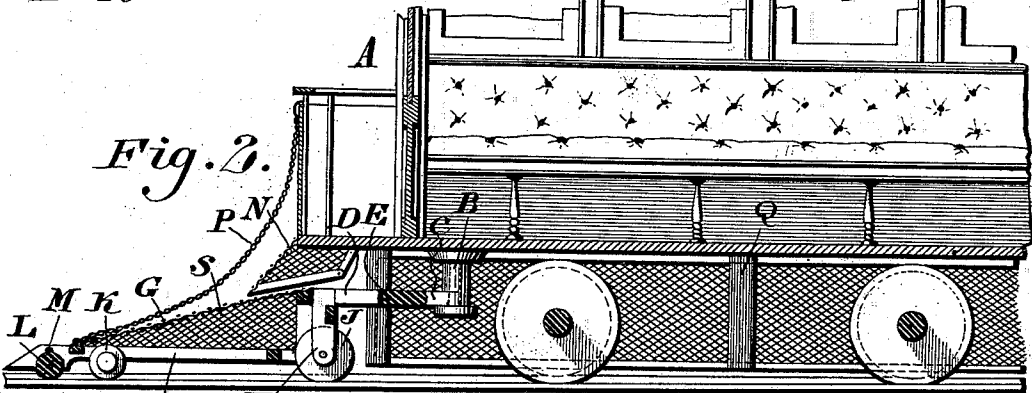
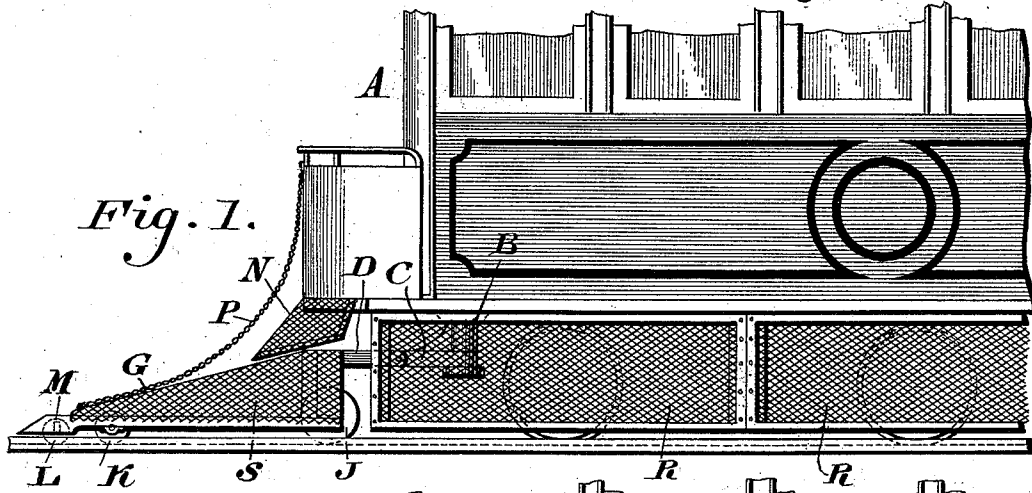

WITNESSES:

P. H. Chapple
L. Dowville

INVENTORS.
Elmer Bockman
Joseph E. Hagan
BY *Wm. A. Diederichsen*
ATTORNEY.

UNITED STATES PATENT OFFICE.

ELMER BOCKMAN AND JOSEPH E. HAGAN, OF PHILADELPHIA, PENNSYLVANIA.

FENDER FOR TROLLEY OR OTHER CARS.

SPECIFICATION forming part of Letters Patent No. 524,883, dated August 21, 1894.

Application filed February 21, 1894. Serial No. 500,964. (No model.)

To all whom it may concern:

Be it known that we, ELMER BOCKMAN and JOSEPH E. HAGAN, citizens of the United States, residing in the city and county of Philadelphia, State of Pennsylvania, have invented a new and useful Improvement in Fenders for Trolley or other Cars, which improvement is fully set forth in the following specification and accompanying drawings.

Our invention consists of a fender for a trolley or other car formed of parts as hereinafter described and claimed.

Figure 1 represents a side elevation of a fender embodying our invention. Fig. 2 represents a vertical section thereof. Fig. 3 represents a bottom plan view thereof. Fig. 4 represents a section on line *x, x*, Fig. 3.

Similar letters of reference indicate corresponding parts in the several figures.

Referring to the drawings: A designates a car of usual construction, on the lower side of whose floor is mounted the boss B, from which projects forwardly the arm C, with which is connected the cross bar D by means of the hinge or knuckle E, said cross bar being attached to or forming part of the frame F of the front fender G, said frame having also connected with it the hangers H, on which are mounted the rollers or wheels J. The side pieces of the frame are mounted on rollers or wheels K, and have on their forward ends the transversely-extending roller L, whose journals are mounted in slots M, in the side pieces of the frame, so that said roller may rise and fall, due to any inequalities in the road bed or track, it being noticed that the wheels J and K, and roller L, are adapted to run on the bed of the rails, so that the heads or flanges of said rails prevent lateral displacement of the fender.

Connected with the dasher or platform of the car is a guard N, whose frame is formed of parts pivoted or hinged together, as most plainly shown in Fig. 2, so that the front portion of said guard may rise and fall, or yield, and thus break the force of a blow that may be imparted to it by any person throw against the same, it being evident that said guard is designed to prevent a person from striking the dasher or platform of the car. It will also be

noticed that the bodies of the fender G and guard N are formed of net-work, whereby a soft or yielding surface is presented to a person that may be thrown thereupon.

It will be seen that the fender is permitted to vibrate in vertical and horizontal directions; owing to the hinge or knuckle E, and the boss B, so that it may adapt itself to the swaying motions of the car and of itself, and thus remain on the rails.

When the roller L is struck, it turns on its axis, and assists in directing a person struck, to the body of the fender, and serves in a measure to break the force of the blow.

A chain or cord P is attached to the frame of the fender G, in any suitable manner, in order to raise the same from the platform when so desired.

On the sides of the body of the car are hangers Q, to which are secured the side fenders R, which are flaring from below, or extend in oblique direction so as to throw-off a person who may be struck, on the side of the car.

The front fender has on the sides thereof the flaring fenders or guards S, whose tendency is to throw-off a person who may be struck by the sides of said fender G, and thus remove them from the wheels of the car.

The side fenders R and S are formed of frames, and bodies of net-work of soft or yielding material, the same possessing the advantages of the fenders G and M.

Having thus described our invention, what we claim as new, and desire to secure by Letters Patent, is—

1. The boss B adapted to depend from the floor of a car, an arm mounted on said boss, a cross bar connected by a hinge with said arm, a frame attached to said cross bar, hangers on said frame carrying wheels J, and a jointed guard secured to the car, and between it and the upper part of said frame, said parts being combined substantially as described.

2. A frame having a cross bar hinged to an arm pivotally mounted on a support, hangers on said frame with wheels on their lower ends, wheels on the sides of said frame, and a roller in front of the same, having a vertical play in its journal bearings, said parts being combined substantially as described.

3. A fender for a car provided with a roller in front thereof, the frame of the fender having slots therein for vertical play of the journals of the roller, substantially as described.

5 4. A frame having a cross bar hinged to a horizontal arm which is pivotally secured to a suitable support below the car, and a guard formed of a jointed frame covering the space

above and between said frame and car, said parts being combined substantially as described.

ELMER BOCKMAN.
JOSEPH E. HAGAN.

Witnesses:

JOHN A. WIEDERSHEIM,
A. P. JENNINGS.