



(51) International Patent Classification:

E04G 3/28 (2006.01) E04G 3/18 (2006.01)  
E04G 3/00 (2006.01)

(21) International Application Number:

PCT/US2020/044566

(22) International Filing Date:

31 July 2020 (31.07.2020)

(25) Filing Language:

English

(26) Publication Language:

English

(30) Priority Data:

62/882,384 02 August 2019 (02.08.2019) US

(71) Applicant: **SAFWAY SERVICES, LLC** [US/US];  
N19W24200 Riverwood Drive, Waukesha, Wisconsin  
53188 (US).

(72) Inventor: **GRUMBERG, Mathieu**; 47 Douglas Road,  
Delmar, New York 12054 (US).

(74) Agent: **GREBE, Laura J.**; HUSCH BLACKWELL LLP/  
Milwaukee, 555 East Wells Street, Suite 1900, Milwaukee,  
Wisconsin 53202 (US).

(81) Designated States (unless otherwise indicated, for every  
kind of national protection available): AE, AG, AL, AM,  
AO, AT, AU, AZ, BA, BB, BG, BH, BN, BR, BW, BY, BZ,  
CA, CH, CL, CN, CO, CR, CU, CZ, DE, DJ, DK, DM, DO,  
DZ, EC, EE, EG, ES, FI, GB, GD, GE, GH, GM, GT, HN,

HR, HU, ID, IL, IN, IR, IS, IT, JO, JP, KE, KG, KH, KN,  
KP, KR, KW, KZ, LA, LC, LK, LR, LS, LU, LY, MA, MD,  
ME, MG, MK, MN, MW, MX, MY, MZ, NA, NG, NI, NO,  
NZ, OM, PA, PE, PG, PH, PL, PT, QA, RO, RS, RU, RW,  
SA, SC, SD, SE, SG, SK, SL, ST, SV, SY, TH, TJ, TM, TN,  
TR, TT, TZ, UA, UG, US, UZ, VC, VN, WS, ZA, ZM, ZW.

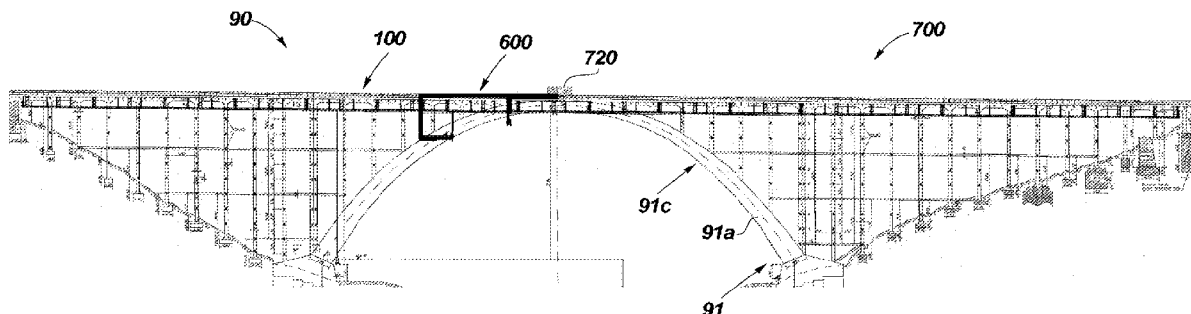
(84) Designated States (unless otherwise indicated, for every  
kind of regional protection available): ARIPO (BW, GH,  
GM, KE, LR, LS, MW, MZ, NA, RW, SD, SL, ST, SZ, TZ,  
UG, ZM, ZW), Eurasian (AM, AZ, BY, KG, KZ, RU, TJ,  
TM), European (AL, AT, BE, BG, CH, CY, CZ, DE, DK,  
EE, ES, FI, FR, GB, GR, HR, HU, IE, IS, IT, LT, LU, LV,  
MC, MK, MT, NL, NO, PL, PT, RO, RS, SE, SI, SK, SM,  
TR), OAPI (BF, BJ, CF, CG, CI, CM, GA, GN, GQ, GW,  
KM, ML, MR, NE, SN, TD, TG).

Published:

— with international search report (Art. 21(3))

(54) Title: MONORAIL SYSTEM AND RELATED SCAFFOLD STRUCTURES, SYSTEMS AND METHODS OF USE

FIG. 1A



(57) Abstract: A monorail assembly includes a first scaffold system comprising at least one framework member being an elongated structure having a bottom chord and a plurality of panel points along the bottom chord; at least one monorail beam; and at least one bracket structure configured to secure to the at least one framework member at or about at least two panel points and to the at least one monorail beam.



**MONORAIL SYSTEM AND RELATED SCAFFOLD STRUCTURES,  
SYSTEMS AND METHODS OF USE**

FIELD OF THE DISCLOSURE

5           This disclosure relates to access systems, and particularly to systems designed to access undersurfaces and side surfaces of large stationary structures. More particularly, this disclosure relates to a monorail system which is used in combination with a scaffold structure and from which a further scaffold structure may be suspended and moved, relative to a structure being accessed, vertically and parallel with the monorail track.

10

BACKGROUND OF THE INVENTION

          There are many instances in the building, repair and restoration industries where it is necessary to access side surfaces and undersurfaces of a structure being worked on and access to these surfaces from below (e.g., erecting standard scaffolding) is not practical or impossible. Some  
15       examples are bridges, and particularly arched bridges, for example, which span a gorge or river. It is oftentimes difficult to access the undersurfaces of these bridges because scaffolding cannot be built upward from the ground, and the presence of arches, which creates a surface of continually changing heights, makes access even more difficult. The same is true with certain side surfaces.

          Suspended scaffolding is known and may be used in certain instances to access such side  
20       surfaces and undersurfaces. Suspended scaffolding comes with its own difficulties. For example, it may not be practical or possible to suspend scaffolding in a location from which workers are able to access the necessary surface. The length of a surface may also be a limiting factor. If the structure being accessed spans a great length, the amount of suspended scaffolding may require multiple rounds of assembly/disassembly to complete the entire job. Further, and particularly with  
25       arched structures, the suspended scaffolding may need to have multiple levels resulting in further complexity and time in assembly/disassembly.

          Therefore, in view of the foregoing, it would be advantageous to provide a system or structure that addresses one or more of the above deficiencies or other problems.

30       SUMMARY

          In accordance with at least some embodiments of the present disclosure, provided herein is a monorail assembly.

          In accordance with at least some embodiments of the present disclosure, provided herein is a monorail system.

In accordance with at least some embodiments of the present disclosure, provided herein is a method of assessing a structure.

In an embodiment, the present disclosure provides a monorail assembly. In accordance with embodiments of the present disclosure, a monorail assembly comprises a first scaffold system comprising at least one framework member being an elongated structure having a bottom chord and a plurality of panel points along the bottom chord; at least one monorail beam; and at least one bracket structure configured to secure to the at least one framework member at or about at least two panel points and to the at least one monorail beam.

In an embodiment, the at least one monorail beam does not contact the at least one framework member when secured to the at least one bracket structure. In another embodiment, the monorail assembly further comprises at least one joist bracket which is connected to the at least one monorail beam and the at least one bracket structure. In still another embodiment, the monorail assembly further comprises at least one joist bracket and wherein the connection of the at least one monorail beam to the at least one framework member is accomplished by the connection of the at least one joist bracket and at least one bracket structure. In another embodiment, the monorail assembly further comprises at least one end stop secured to the at least one monorail beam.

In accordance with an embodiment, the monorail assembly further comprises at least two trolley structures slidingly secured to the first scaffold system and configured to secure a second scaffold system. In an embodiment, the at least two trolley structures are slidingly secured to the at least one elongated structure. In another embodiment, the first scaffold system comprises at least two framework members.

In an embodiment, the present disclosure provides a monorail system. IN accordance with embodiments of the present disclosure, a monorail system comprises a first scaffold system; a monorail assembly secured to the first scaffold system and comprising at least one monorail beam; and a second scaffold system suspended from the at least one monorail beam.

According to an embodiment, the second scaffold system moves both laterally along the at least one monorail beam and vertically with respect to the at least one monorail beam. In another embodiment, the first scaffold system is a suspended articulating scaffold system. In a further embodiment, the monorail assembly further comprises at least one bracket structure configured to secure to the first scaffold system. In yet another embodiment, the second scaffold system is a monorail car. In other embodiments, the second scaffold system is a suspension scaffold. In a further embodiment, the monorail assembly further includes at least two trolley structures slidingly secured to the first scaffold system.

## BRIEF DESCRIPTION OF THE FIGURES

FIG. 1A is a side schematic view of a scaffold system containing a plurality of monorail systems in accordance with embodiments of the present disclosure;

FIG. 1B is a detailed view of callout 1B of FIG. 1A;

5 FIG. 2 is a side view of a monorail assembly secured to the underside of a scaffold system, in accordance with embodiments of the present disclosure;

FIG. 3A is a top perspective view of a joist bracket for use with a monorail assembly, in accordance with embodiments of the present disclosure;

FIG. 3B is an exploded view of the joist bracket of FIG. 3A;

10 FIG. 3C is a side perspective view of the assembled joist bracket of FIG. 3B;

FIG. 4A is a side view of a monorail beam for use with a monorail assembly, in accordance with embodiments of the present disclosure;

FIG. 4B is an end view of the monorail beam of FIG. 4A;

15 FIG. 5A is a side perspective view of a monorail beam and two monorail joining bracket assemblies, in accordance with embodiments of the present disclosure;

FIG. 5B illustrates a portion of FIG. 5A in further detail;

FIGS. 5C and 5D are exploded views illustrating the assembly of a monorail joining bracket assembly on a monorail beam, in accordance with embodiments of the present disclosure;

20 FIG. 5E is an end perspective view illustrating the assembled monorail joining bracket assembly of FIGS. 5C and 5D;

FIG. 6A is a side perspective view of an end stop for a monorail assembly, in accordance with embodiments of the present disclosure;

FIG. 6B is an exploded view of the end stop of FIG. 6A;

FIG. 6C is an end perspective view of the assembled end stop of FIG. 6A;

25 FIG. 7A is a top perspective view of a portion of a scaffold system with a joist bracket assembled and shown prior to attachment of a monorail beam, in accordance with embodiments of the present disclosure;

FIG. 7B is a top view of the embodiment of FIG. 7A with the monorail beam being positioned, in accordance with embodiments of the present disclosure;

30 FIG. 7C is a detailed top perspective view of a portion of the embodiment shown in FIG. 7A with the monorail beam in position and showing the attachment of the monorail beam to the joist bracket, in accordance with embodiments of the present disclosure;

FIG. 7D is a side view of the embodiment shown in FIG. 7C with the monorail beam connected to the joist bracket, in accordance with embodiments of the present disclosure;

FIG. 7E is a top perspective view illustrating the attachment of an end stop, in accordance with embodiments of the present disclosure;

FIG. 7F is a top perspective view of the embodiment shown in FIG. 7E with the end stop fully assembled;

5 FIG. 8A is a side view showing a monorail assembly secured to a portion of a suspended scaffold system, in accordance with embodiments of the present disclosure;

FIG. 8B is a bottom perspective view of the embodiment shown in FIG. 33A;

FIG. 8C is a side perspective view of the embodiment shown in 33A;

10 FIG. 9 is top perspective view of an interconnection structure for use in a suspended scaffold system, in accordance with the present disclosure;

FIG. 10 is top view of the interconnection structure of FIG. 9, in accordance with the present disclosure;

FIG. 11 is a side elevation view of the interconnection structure of FIG. 9, in accordance with the present disclosure;

15 FIG. 12 is bottom view of the interconnection structure of FIG. 9, in accordance with the present disclosure;

FIG. 13 is a top perspective view of an interconnection between an interconnection structure and joist for use in a suspended scaffold system, in accordance with the present disclosure;

20 FIG. 14A is an exploded top perspective view of the interconnection of FIG. 13, in accordance with the present disclosure;

FIG. 14B is a top perspective view of the view in FIG. 14A, in accordance with the present disclosure;

25 FIG. 15 is a top perspective view of a single unit of a suspended scaffold system, in accordance with embodiments of the present disclosure;

FIG. 16A is a top perspective view of an interconnection between a joist and deck support for a suspended scaffold system, in accordance with embodiments of the present disclosure;

FIG. 16B is a exploded reverse top perspective view of the interconnection of FIG. 16A, in accordance with embodiments of the present disclosure;

30 FIG. 16C is a close-up top perspective view of the interconnection of FIG. 16B, in accordance with embodiments of the present disclosure;

FIG. 17 is a top perspective view of a single unit of a suspended scaffold system, in accordance with embodiments of the present disclosure;

FIG. 18 is a top perspective view of a second embodiment of a single unit of a suspended scaffold system, in accordance with embodiments of the present disclosure;

FIG. 19A is a top perspective view of a joist, interconnection structure, and portion of a deck retainer assembly for use in a suspended scaffold system, in accordance with embodiments  
5 of the present disclosure;

FIG. 19B is an exploded close-up perspective view of the joist, interconnection structure, and deck retainer assembly of FIG. 19A, in accordance with embodiments of the present disclosure;

FIG. 19C is an end sectional view of a joist and a portion of a deck retainer assembly such  
10 as shown in FIG. 19A, in accordance with embodiments of the present disclosure;

FIG. 20 is a top perspective view of an embodiment of a work platform of a suspended scaffold system, in accordance with embodiments of the present disclosure;

FIG. 21 is a bottom perspective view of the embodiment shown in FIG. 20, in accordance with embodiments of the present disclosure;

FIG. 22 is a top perspective view of a portion of the work platform shown in FIG. 20,  
15 having a single unit of the work platform for a suspended scaffold system shown prior to articulation, in accordance with embodiments of the present disclosure;

FIG. 23 is a top perspective view of the embodiment in FIG. 22 with the single unit undergoing articulation, in accordance with embodiments of the present disclosure;

FIG. 24 is a top perspective view of the embodiment in FIG. 23 with the single unit  
20 undergoing further articulation, in accordance with embodiments of the present disclosure;

FIG. 25 is a top perspective view of the embodiment in FIG. 24 with the single unit undergoing further articulation, in accordance with embodiments of the present disclosure;

FIG. 26 is a top perspective view of the embodiment in FIG. 22 with the single unit having  
25 completed articulation, in accordance with embodiments of the present disclosure;

FIG. 27A is a top perspective view of a joist and interconnection structure subassembly for use in a suspended scaffold system, in accordance with embodiments of the present disclosure;

FIG. 27B is a top perspective view of a second embodiment of a joist and interconnection structure subassembly for use in a suspended scaffold system, in accordance with embodiments of  
30 the present disclosure;

FIG. 27C is a top perspective view of a third embodiment of a joist and interconnection structure subassembly for use in a suspended scaffold system, in accordance with embodiments of the present disclosure;

FIG. 27D is a top perspective view of a fourth embodiment of a joist and interconnection structure subassembly for use in a suspended scaffold system, in accordance with embodiments of the present disclosure;

5 FIG. 28A is a top view of an embodiment of a suspended scaffold system, in accordance with embodiments of the present disclosure;

FIG. 28B is a top view of a second embodiment of a suspended scaffold system, in accordance with embodiments of the present disclosure;

FIG. 29 is a sectional elevation view of a suspended scaffold system suspended from a structure, in accordance with embodiments of the present disclosure;

10 FIG. 30A is a top perspective view of an interface between an interconnection structure and a suspension connector for use with a suspended scaffold system, in accordance with embodiments of the present disclosure;

FIG. 30B is a close-up of the interface shown in FIG. 30A, in accordance with embodiments of the present disclosure;

15 FIG. 31A is a sectional elevation view of an interconnection structure, suspension connector and a structure attachment device for use with a suspended scaffold system, in accordance with embodiments of the present disclosure;

20 FIG. 31B is a close-up sectional elevation view of the interconnection between the interconnection structure and suspension connector of FIG. 31A, in accordance with embodiments of the present disclosure;

FIG. 32A is a top, perspective view of an auxiliary suspender mounting bracket for use with a suspended scaffold system, in accordance with embodiments of the present disclosure;

FIG. 32B is a plan view of the auxiliary suspender mounting bracket of FIG. 32A;

25 FIG. 32C is a front elevation view of the auxiliary suspender mounting bracket of FIG. 32A;

FIG. 32D is a side elevation view of the auxiliary suspender mounting bracket of FIG. 32A;

FIG. 33 is an elevation sectional view showing suspension of a work platform for a suspended scaffold system from a structure via an auxiliary suspender mounting bracket, in accordance with embodiments of the present disclosure;

30 FIG. 34A is an elevation view of an embodiment of a suspended scaffold system employed in relation to an arched bridge, in accordance with embodiments of the present disclosure;

FIG. 34B is an elevation view of a second embodiment of a suspended scaffold system employed in relation to an arched bridge, in accordance with embodiments of the present disclosure;

FIG. 34C is an elevation view of a third embodiment of a suspended scaffold system employed in relation to a structure, in accordance with embodiments of the present disclosure;

FIG. 35 is a side perspective view of a second embodiment of a suspended scaffold system employed in relation to a structure, in accordance with embodiments of the present disclosure;

- 5        FIG. 36 is a detailed view of callout 7 of FIG. 1A;  
      FIG. 37 is a cross-sectional view taken from A-A of FIG. 1A;  
      FIG. 38 is a cross-sectional view taken from B-B of FIG. 1A;  
      FIG. 39 is a detailed view of callout 2 of FIG. 37;  
      FIG. 40 is a detailed view of callout 3 of FIG. 37;  
10       FIG. 41 is a detailed view of callout 4 of FIG. 37;  
      FIG. 42 is a detailed view of callout 5 of FIG. 37;  
      FIG. 43 is a detailed view of callout 6 of FIG. 38;  
      FIG. 44 is a detailed view of callout 1 of FIG. 1A;  
      FIG. 45 is a detailed view of callout 1 of FIG. 44; and  
15       FIG. 46 is a cross-sectional view taken from C-C of FIG. 44; and  
      FIG. 47 is a cross-sectional view taken from D-D of FIG. 1A.

Although certain preferred embodiments of the present disclosure will be shown and described in detail, it should be understood that various changes and modifications may be made without departing from the scope of the appended claims. The scope of the present disclosure will  
20 in no way be limited to the number of constituting components, the materials thereof, the shapes thereof, the relative arrangement thereof, etc., and are disclosed simply as an example of an embodiment. The features and advantages of the present disclosure are illustrated in detail in the accompanying drawings, wherein like reference numerals refer to like elements throughout the drawings.

25

## DETAILED DESCRIPTION

As a preface to the detailed description, it should be noted that, as used in this specification and the appended claims, the singular forms “a”, “an” and “the” include plural referents, unless the context clearly dictates otherwise.

30        Articulation, as used herein, is defined as the capability to swing, and/or rotate, about a pivot point or axis.

As used herein, the terms “single section,” “unit,” or “single unit,” when used in reference to a scaffold system, refer to a planar structure composed of at least three corners and the elongated members (e.g., joist, bars, framework, etc.) and other structures which support and define a

flooring area. The terms “section” and/or “unit” can be used interchangeably. Moreover, it will be appreciated that adjacent sections or units of a scaffold system may share one or more components, e.g., two adjacent sections of a scaffold system may have a common corner or share a framework member.

5           FIG. 1A is a side schematic view of a plurality, specifically three, monorail systems **700** employed with respect to a structure **90**. Specifically, shown in FIG. 1A is a scaffold system **100** containing a plurality of monorail assemblies **600** in accordance with embodiments of the present disclosure, and FIG. 1B is a detailed view of callout 1B of FIG. 1A. Shown in FIGS. 1A and 1B is structure **90**, which in the present embodiment is an arched bridge, but in further embodiments  
10           may be any structure to be accessed. Each arch **91** of the bridge includes 3 distinct surfaces – two side surfaces **91a**, **91b** (not shown) and a lower (under) surface **91c**. In order to access each of the three surfaces **91a**, **91b**, **91c**, the bridge **90** includes four monorail assemblies **600**, two on either side of the bridge **90**. Each of the monorail assemblies **600** is secured to the under portion of a scaffold system **100**, an exemplary embodiment of which is shown in FIG. 2.

15           The monorail assemblies **600** are used to suspend further scaffold systems **800**. In the exemplary embodiment shown in FIGS. 1A-1B, suspended from the monorail assemblies **600** is a total of three scaffold systems – one to access each of the three surfaces **91a**, **91b** and **91c**. To access the side surfaces **91a**, **91b**, a scaffold system is suspended from a single monorail assembly **600** on either side of the bridge **90**. That is, each of the scaffold systems used to access the side  
20           surfaces **91a**, **91b** is suspended from a single monorail assembly **600**. In contrast, the scaffold system used to access the underside surface **91c** is suspended from two monorail assemblies **600** such that the scaffold system spans the width of the underside surface **91c** and is supported on both ends.

          Together, each monorail assembly (or monorail assemblies) **600**, the scaffold system to  
25           which the monorail assembly (or assemblies) is (are) attached **100**, and the scaffold system suspended from the monorail assembly (or assemblies) form a monorail system **700**. Each monorail system **700** is operatively connected to a generator **720** to provide power to the monorail system **700**. The generators **720** provide power to accomplish movement of the scaffold system **700** both along the monorail assembly (or assemblies) and vertically.

30           The monorail assembly **600** will not be described in further detail with reference to FIGS. 2-7F.

### Monorail Assembly

          FIG. 2 illustrates a monorail assembly **600**. In the embodiment shown, the monorail assembly **600** is secured to under structures of a work platform system **100**. The monorail

assembly **600** includes joist brackets **605**, monorail beams **630**, monorail joining bracket assemblies **650** and end stops **680** (only one shown).

#### *Joist Bracket*

FIGS. 3A-3C illustrate a joist bracket **605** in further detail. Each joist bracket **605** has two  
5 bracket plates **606**. Each bracket plate **606** has a generally stepped configuration with a lower wall  
**607** generally perpendicular to a first midwall **608**, a second midwall **609** generally perpendicular  
to the first midwall **608**, and an upper wall **610** generally perpendicular to the second midwall **609**.  
In the embodiment shown, the transitions **611** between the respective walls **607**, **608**, **609**, **610** is  
rounded; however, in further embodiments, the transitions may be sharp or more gradual. The  
10 lower wall **607** and upper wall **610** each contain a plurality of openings **612**, **614**, respectively,  
therethrough, each of which is capable of receiving a bolt. As shown perhaps best in FIG. 3B,  
openings **614** are tunneled openings, that is, the openings have a flange around them on one side.  
The plates **606** each include a further plurality of openings **613**, each opening of which extends  
through at least a portion of the upper wall **610** and first and second midwalls **608**, **609**. In the  
15 embodiment shown, each of the openings **613** of the further plurality of openings is squared.

Referring to FIG. 3B, specifically, when securing a joist bracket **605** to a scaffold frame  
member **30** of scaffold system **100**, two bracket plates **606** are used. The bracket plates **606** are  
positioned on either side of the frame member and secured together using a plurality of bolts **615**  
and nuts **616**.

20 In the embodiment shown, the scaffold frame member **30** has a structure similar to a truss  
having an upper chord **32** and a lower chord **33**, with a number of diagonal support members **38**.  
The point at which two diagonal support members **38** meet along a chord **32**, **33** is a panel point  
**710**. The joist bracket **605** is specifically designed to have a length which spans across at least  
two panel points **710**, with each panel point **710** contained between the plates **606** being aligned  
25 with an opening **613**. The upper walls **610** of the respective bracket plates **606** sandwich the  
diagonal support members **38**, but do not press against or exert a force on the diagonal support  
members **38**. The flanges of the tunneled openings **614** prevent the bracket plates **606** from  
tightening against the diagonal support members **38**. Rather, the second midwall **609** sits on and  
is supported by the lower chord **33**.

30 It will be appreciated that the exact dimensions and appearance of the bracket plates **606**  
and the joist bracket **605** overall may vary depending on the scaffold system with which the joist  
bracket **605** will be used. Specifically, the existence of panel points, distance between panel points,  
and shape of chords may all influence the specific design of the joist bracket **605**.

#### *Monorail Beam*

FIGS. 4A and 4B illustrate an exemplary monorail beam **630**. A monorail beam **630** is an I-beam having a central member **631** with flanges **632** projecting from length of the central member **631** in a generally perpendicular direction relative to the central member **631**. The ends of the monorail beam **630** include a series of openings **635** which are used to secure various additional components of the monorail assembly **600** as described in further detail below.

#### *Joining Bracket Assembly*

To join monorail beams **630**, a joining bracket assembly **650** is used. FIGS. 5A-5E illustrate an exemplary joining bracket assembly **650** used in the present disclosure. In short, a joining bracket assembly **650** engages at least two of the openings **635** on one end of a first monorail beam **630** and at least two openings **635** on a second adjacent monorail beam **630**. The joining bracket assembly **650** also secure a monorail beam **630** to the joist brackets **605**.

In the embodiment shown in FIGS. 5A-5E, each joining bracket assembly **650** includes a side plate **651**, a spacer plate **657** and a safety plate clamp **658**. As shown in FIG. 5C, the side plate **651** as two portions – a first portion **652** which contacts the under surface of one of the flanges **632** of the monorail beam **630** and a second portion **653** which contacts the central member **631** of the monorail beam **630**. The second portion **653** includes a first plurality of openings (not shown) and a second plurality of openings **642**. When the side plate **651** is properly aligned with a monorail beam **630**, the openings of the first plurality of openings are align with so as to be coaxial with at least two opening **635** of the monorail beam **630**. Bolts **661**, secured in place with nuts **661a** pass through the coaxial openings to hold the side plate **651** to the monorail beam **630**. As will be shown with respect to FIG. 7D, openings of the second plurality of openings **642** align with additional openings **635** on the monorail beam **630** and receive pins to further secure monorail beams **630** to one another.

When properly in position, the first portion **652** is against the under surface of one of the flanges **632** of the monorail beam **630** with spacer **654** flush against the flange **632** of the monorail beam **630**. It will be appreciate that spacer **655** will be likewise flush against the flange of a second adjacent monorail beam when the monorail beam **630** is connected to an adjacent monorail beam. A third spacer **656** is provided as a separate component on the side of the monorail beam **630** opposite the first portion **652**. Each of the spacers **654**, **655**, **656** includes at least one opening **660**, **667** and **668**, respectively, therethrough which is configured to receive a bolt **670**.

As shown perhaps best in FIG. 5E, the spacers **654**, **655**, **656** extend the width of the first portion **652** and raise the height of the first portion **652**. The spacer plate **657** and safety plate clamp **658** then clamp around the upper flanges **632** of the monorail beam **630** to lock the joining bracket assembly **650** in position on the monorail beam **630**. The spacer plate **657** is a generally

planar, rectangular structure having an opening **663** through the ends which, when positioned with respect to a first portion **651**, are coaxial with the at least one opening **660** and **668** of the spacer **654** and spacer **656**, respectively.

The safety plate clamp **658** is likewise a generally planar, rectangular structure having an opening **665** through the ends and a flange extension **672**. When positioned with respect to a first portion **651**, the openings **665** are coaxial with the respective openings **663** and at least one opening **660** of the spacer plate **657**, spacer **654** and spacer **656**, respectively. Bolts **670** extend through the respective coaxial openings **667**, **663** and **660** and are secured with a nut **662** to complete the joining bracket assembly **650**.

It will be appreciated that the structure of the joining bracket assembly **650** creates a space between the top of the flanges **652** and the flange extension **672** of the safety plate clamp **658**. As shown perhaps most clearly in FIG. 7C, the space receives the lower wall **607** of the joist bracket **605**. When a joining bracket assembly **650** is positioned with respect to a joist bracket **605**, one of the openings **612** of the lower wall **607** will be coaxial with the at least one opening **667** of spacer **655**. A bolt secured through openings **612** and **667** secures the monorail beam **630** to the joist bracket **605** and therefore the scaffold system **100**.

#### *End Stop*

FIGS. 6A-6C illustrate an end stop **680**. End stop **680** has a structure very similar to the joining bracket assembly **650** and indeed reuses a number of components. In the exemplary embodiment shown, the end stop **680** includes a side plate **681**, a spacer plate **687** and a safety plate clamp **688** having structures substantially the same as side plate **651**, a spacer plate **657** and a safety plate clamp **658**. The difference is that the joining bracket assembly **650** is secured to a portion of a monorail beam **630** while the end stop **680** itself includes a stop portion **690** which is essentially a portion of monorail beam **630'** having a terminal plate **691** to stop further travel of a structure along the monorail beam **630'**.

FIGS. 7A-7F illustrate assembly steps for an exemplary monorail assembly **600**. As shown in FIGS. 7A and 7B, a scaffold system **100** is in position with joist brackets **605a**, **605b** positioned opposite one another on opposing framework pieces. A monorail beam **630** is being lowered into position, such as by a crane. Turning now to FIG. 7C, once the monorail beam **630** is in position, with the lower wall **607** between the flange extension **672** and the flanges **632** of the monorail beam, bolts **670** secure the monorail beam **630** to the joist bracket **605** and therefore scaffold frame member **30**. The monorail beam **630** is connected in the same manner to both joist brackets **605a** and **605b**.

As shown in FIG. 7D, two adjacent monorail beams **630** are in position relative to one another and secured using bolts **661** and pins **741** are inserted through the second plurality of openings **642** of the second portion **653** to further secure adjacent monorail beams **630** to one another.

5 As shown in FIGS. 7E and 7F, once the final monorail beam **630** is in position, an end stop **680** is secured to the end of the final monorail beam **630** using the same method to secure adjacent monorail beams **630** to one another.

#### Scaffold System/Monorail Assembly

10 FIGS. 8A-8C show the connection between a scaffold system **100** and monorail assembly **600** in further detail. The joist brackets **605** are shown secured to scaffold frame members **30** spanning two panel points **710** each. The second midwalls **609** of the plates **606** rests on the lower chord **33** of the scaffold frame members **30**. The individual monorail beams **630** are connected to one another using joining bracket assembly **650**.

15 From FIGS. 8A-8C, it will be appreciated that adjacent monorail beams **630** are secured to one another by two joining bracket assembly **650** arranged as mirror images of one another. That is, for a given monorail beam joint, a first joining bracket assembly **650** is positioned with respect to the monorail beams **630** with its side plate **651** against a first side of the central member **631**. A second joining bracket assembly **650** is positioned with respect to the monorail beams **630** with its side plate **651** against the other side of the central member **631**. As a result, the side plates **651**  
20 share a common set of bolts **661** and pins **741**.

#### Exemplary Scaffold Systems

##### *Suspended Articulating Scaffold System*

In the embodiments shown herein, the monorail assembly **600** is shown secured to an exemplary scaffold system which includes scaffold frame members **30** which have upper and lower  
25 chords **32**, **33**. FIGS. 9-34C further describe an exemplary scaffold system which includes such scaffold frame members which is a suspended, articulating scaffold system. However, in further embodiments, it will be appreciated that the monorail assembly **600** may be secured to any style scaffold system, more preferably any style suspended scaffold system.

##### *Interconnection Structure*

30 FIG. 9 illustrates an interconnection structure **10** for a suspended, articulating scaffold system. The interconnection structure **10** is configured so that, when attached to a scaffold frame member **30** (see FIG. 13), allows for articulation of both the interconnection structure **10** and the scaffold frame member **30**. An interconnection structure is any structure which connects one or

more joist or other elongated structural member, such as a node, hinge, pivot, post, column, center, shaft, spindle, or the like.

The interconnection structure 10 includes a top element 11 and a bottom element 12 spaced at distal ends of a middle section 15. The top element 11 and bottom element 12 may be substantially planar in configuration, as well as, being parallel to each other. The top element 11 and bottom element 12, in the embodiment shown, are octagonal in plan. In other embodiments, the top element 11 and bottom element 12 can have other shapes, such as square, polygonal, circular, etc.

The middle section 15 may be a cylindrical section wherein a longitudinal axis of the middle section 15 is normal to the planes of the top element 11 and bottom element 12. In the embodiment shown, the middle section 15 is a right circular cylinder. However, in alternative embodiments, the middle section 15 can have different shape, such as any prism having a polygonal face. In FIG. 9, a lower portion of the middle section 15 is removed for clarity purposes to show that the middle section 15 is hollow.

There are a plurality of openings 13, 14, extending through both the top element 11 and bottom element 12, respectively. The plurality of openings 13 (e.g., 13A, 13B, 13C, 13D, 13E, 13F, 13G, 13H) are interspersed on the top element 11 so as to offer various locations for connecting to one, or more, scaffold frame members 30 (see e.g., FIG. 13). The plurality of openings 14 (e.g., 14A, 14B, 14C, 14D, 14E, 14F, 14G, 14H) are similarly spaced on the bottom element 12 so that respective openings (e.g., 13A and 14A) are coaxial.

At the center of the top element 11 is a center opening 16. In an embodiment, the center opening 16 receives a suspension connector 80 (see e.g., FIGS. 29-33). In other embodiments, the center opening 16 receives a vertical support member 75 (see e.g., FIG. 29). The center opening 16 may be generally cruciform in configuration due to its center opening area 19 with four slots 17 (e.g., 17A, 17B, 17C, 17D) extending therefrom. Transverse to each of the four slots 17A, 17B, 17C, 17D, and interconnected thereto, are a series of cross slots 18A, 18B, 18C, 18D, whose utility will be apparent as discussed below. For added strength a second reinforcing plate 20 is added to the underside of the top element 11 wherein openings on the reinforcing plate 20 correspond to the center opening 16 configuration and all the ancillary openings thereto (17, 18, 19). A handle 22 is optionally added to the side of the middle section 15.

FIGS. 10, 11, and 12 show the top, side, and bottom view of the same embodiment of the interconnection structure 10 depicted in FIG. 2. FIG. 5 shows *inter alia* a bottom opening 23 on the bottom element 12. In an embodiment, the bottom opening 23 receives a vertical support member (see e.g., FIG. 29). The bottom face of the reinforcing plate 20 can be seen within the

bottom opening 23. Attached to the reinforcing plate 20 and the interior face of the middle section 15 are a plurality of gussets 25 that provide added support to the interconnection structure 10.

### *Scaffold Frame Member*

FIG. 13 depicts a top perspective view of the interconnection between a single interconnection structure 10 and a single scaffold frame member 30, while FIGS. 14A and 14B shows an exploded close-up view, and a regular perspective close-up view, respectively, of a typical connection detail between the interconnection structure 10 and scaffold frame member 30. When used in a suspended, articulating scaffold system, a scaffold frame member 30 is referred to as a joist 30.

The joist 30 includes an upper element 32 and a bottom element 33. Interspersed between elements 32, 33 are a plurality of diagonal support members 38. Each element 32, 33 is made of two L-shaped pieces of angle iron 39A, 39B. Elements 32, 33 typically may be identical in construction, with the exception being upper element 32 includes connector holes 54A, 54B at its midspan (See e.g., Figs. 16A, 16B). The joist 30 includes a first end 31A and a second end 31B. At either end 31A, 31B of both the upper element 32 and bottom element 33 extends an upper connecting flange 35 and a lower connecting flange 36. Through both upper and lower connection flanges 35, 36 are connecting holes 37. Thus, there are four upper connecting flanges 35A, 35B, 35C, 35D; four lower connecting flanges 36A, 36B, 36C, 36D. Thus, at a first end 31A, extending from the upper element 32, is an upper connection flange 35A and lower connection flange 36A, with a connecting hole 37A therethrough. Similarly, at the second end 31B of the upper element 32, extends an upper connection flange 35B and lower connection flange 36B, with a connecting hole 37B therethrough. Continuing, at the first end 31A of the lower element 33 extends an upper connection flange 35D and lower connection flange 36D. Through these connection flanges 35D, 36D are a connecting hole 37D. At the second end 31B of the joist 30 extending from the lower element 33 is an upper connection flange 35C and lower connection flange 36C with a connecting hole 37C therethrough.

Interior to each of the connector holes 37A, 37B, 37C, 37D are additional locking holes 360A, 360B, 360C, 360D also located on the connection flanges 35A, 35B, 35C, 35D.

As Figs. 14A and 14B depict in further clarity, a pin 40 may be placed through the connecting holes 37 any two corresponding top and bottom openings 13, 14 of the interconnection structure 10. In this manner, the joist 30 can be connected in a virtually limitless number of ways, and angles, to the interconnection structure 10. For example, a pin 40 may be placed in through an upper connection flange 35A; through an opening 13A; through a lower connection flange 36A (all of the first end 31A of the upper element 32); through an upper connection flange 35D; through

an opening 14A; and, then through the lower connection flange 36D. In this scenario, the pin 40 further threads through connecting holes 37A and 37D. The pin 40 includes two roll pins 42 at its upper end. The lower of the two roll pins 42 acts as a stop, thereby preventing the pin 40 from slipping all the way through the joist 30 and interconnection structure 10. The upper roll pin 42 acts as a finger hold to allow easy purchase and removal of the pin 40 from the joist 30 and interconnection structure 10.

The design of these various parts is such that free rotation of both the joist 30 and interconnection structure 10 is allowed, even while the joist 30 and interconnection structure 10 are connected together. Rotational arrow  $R_1$  show the rotation of the joist 30, while rotational arrow  $R_2$  shows the rotation of the interconnection structure 10. These rotational capabilities of the joist 30 and interconnection structure 10 provide, in part, the articulating capability of the present invention.

While free rotation of a joist 30 and interconnection structure 10 is allowed, such free rotation is restricted when a section or unit of a modular space frame support system is assembled and ready for use. In an embodiment, free rotation is restricted by at least one of: i) an additional (second) pin that is to be located proximate a perimeter of the at least one interconnection structure; and ii) at least a portion of a work platform when the platform is positioned with respect to the interconnection structures and joists in an extended position.

In the particular embodiment shown, a second optional locking pin 40B may be added through the locking holes 360A, 360C, 360C, 360D at the end of joist 30 in order to lock the joist 30 to prevent articulation, if so desired. The locking pin 40B abuts a groove 24 on the interconnection structure 10. The grooves are situated on both the top element 11 and bottom element 12. Similarly, the locking pin 40B can include additional two roll pins 42 as does the pin 40.

It should be apparent to one skilled in the art that, while the joist 30 depicted in the figures is made of particular shaped elements, there are other embodiments that provide the aspects of the present invention. A joist is any elongate structural member adapted for bearing or supporting a load, such as a bar joist, truss, shaped-steel (i.e., I-beam, C-beam, etc.), or the like. For example, the joist 30 in the figures may commonly be called a bar joist, or open-web beam or joist. The joist 30 could also be made of shaped steel (e.g., wide flange elements, narrow flange members, etc.), or other suitable shapes and materials.

The assembly of interconnection structures 10 and joists 30 to form a section or unit 115 of a modular space frame support system 100 is discussed in further detail below.

FIG. 15 depicts a single section or unit 115 of a modular space frame support system 100 made using interconnection structures 10 and joists 30. Note that four interconnection structures 10A, 10B, 10C, 10D are interconnected with four joists 30A, 30B, 30C, 30D. FIG. 15 shows the single frame unit 115 that is square in plan. It should be apparent to one skilled in the art, that other shapes and configurations can be made. By varying the lengths of joists 30, for example, other shapes can be made. For example, a frame unit 115 that is rectangular can be constructed. Also, by attaching joists 30 to various openings 13, 14 of the interconnection structure 10, various angles at which the joists 30 interconnect with the interconnection structure 10 can be achieved. For example, a frame unit 115 that is triangular in plan (not shown) may be constructed. Thus, by changing joist 30 lengths (See e.g., Figs. 27A-27D) and/or changing the angle(s) at which the joists 30 extend from the interconnection structure 10, virtually any shape and size frame unit 115, and resulting modular space frame support system 100 and work platform systems 200 may be constructed. Further, different shape, size, and configuration of frame sections or units 115 can be joined and abutted with each other, so that the modular space frame support system design, and work platform system design, is virtually completely customizable. This adaptability of the modular space frame support system 100 provides a convenient way to gain access to virtually any shape work area required in construction.

Figs. 16A, 16B, and 16C depict various views, and close-up views of the interconnection between a middle support deck joist 52 and the joist 30. The middle support deck joist 52 provides added support to support platforms 50 (see e.g., FIG. 17) and may span between two joists 30. At either end of the middle support deck joist 52 is a pin 53 which communicates with a corresponding hole 54 on the upper portion of the joist 30. For example, FIG. 16B depicts an exploded view of the interconnection, wherein pin 53 will go in hole 54A. In this manner, movement (both lateral and axial) of the middle support deck joist 52 is minimized.

FIG. 17 shows the embodiment of single frame section or unit 115 from FIG. 15 wherein a platform 50A has been placed on the single frame unit 115 thus transforming the single frame unit 115 into a single unit of a work platform system 200. The platform 50A rests, in this embodiment, on the middle support deck joist 52A and on the joists 30A, 30B, 30D. The edges of the platform 50A may rest on the top of the middle support deck joist 52 and the angle iron 39A, 39B on the top of the applicable joists 30A, 30B, 30D. The configuration of the top of the middle support deck joist 52 and the angle iron 39A, 39B is such that vertical and horizontal movement of the platform 50A is avoided. The work platform 50 typically is sized to be a 4" x 8' piece of material. The work platform 50A may include a wood panel 51A, for example. Suitable work platform 50 may be made from metal (e.g., steel, aluminum, etc.), wood, plastic, composite, or other suitable

materials. Similarly, the work platform 50 may be made of items that are solid, corrugated, grated, smooth, or other suitable configurations. For example, the work platform 50 may be wood sheeting, plywood, roof decking material, metal on a frame, grating, steel sheeting, and the like. Thus, after placing a first work platform 50A on the unit 115 of the modular space frame support system 100, an installer may continue in this manner and place additional multiple work platforms 50A, 50B, such as shown in FIG. 18, so that an entire upper frame 110 and/or lower frame 120 is covered with wood platforms 51A, 51B so that a complete work platform system 200 is created.

FIGS. 19A, 19B, and 19C show various close-up views of an additional, optional feature that can be used with a modular space frame support system 100 to form a work platform system 200. A deck retainer plate 60 may be placed over the spacing between the multiple work platforms 50. The deck retainer plate 60 may include a plurality of holes 62 so that a plurality of deck retainer bolts 61 may adhere the deck retainer plate 60 to the joist 30. The deck retainer plate 60 is one way in which to secure work platforms 50 to the modular space frame support system 100.

As FIGS. 20 and 21 depict, there is virtually no limit as to the size and shape of the modular space frame support system 100 and work platform system 200 that can be made in accordance with the present disclosure. FIGS. 20 and 21 show top and bottom perspective views, respectively, of one large rectangular embodiment of a single level of modular space frame support system 100 with work platforms 50 in place to make a work platform system 200.

As stated above, one deficiency of numerous existing work platforms are their inability to be installed *in situ* and also their inability to be relocated, extended, or removed, while a portion of the work platform is already installed in place. The present disclosure overcomes this deficiency. That is, the modular space frame support system and resulting work platform system allows for a worker, or workers, to add on additional sections of a modular space frame support system 100 (and, ultimately, work platform system 200) while this worker(s) is physically on an existing installed portion or unit of a modular space frame support system and/or work platform system. That is the worker(s) can extend, relocate, or remove a portion of a work platform system 200 and/or modular space frame support system 100 with only the need of hand tools. No mechanical tools, hoists, cranes, or other equipment is required to add to, subtract from, or relocate the modular space frame support system 100. This advantage, thus, offers savings in labor, time, and equipment.

For as FIGS. 22 through 26 depict the gradual articulation of just one section or unit of a single section or unit 115 of a modular space frame support system 100, when made using interconnection structures 10 and joists 30, into place. This can be readily accomplished by one, or two, workers by simply placing sequentially an additional joist 30D off of an existing

interconnection structure 10A. Then a “new” interconnection structure 10D is connected to the first joist 30D. A second additional joist 30E is connected to the interconnection structure 30D. Further, another interconnection structure 10E and joist 30F are connected so that the final joist 30F is connected back to an existing interconnection structure 10B. In this manner, a worker(s) can install a new section or unit of a modular space frame support system (e.g., made up of “new” interconnection structures 10D, 10E and “new” joists 30D, 30E, 30F) off of an existing section of a modular space frame support system (e.g., made up of *inter alia* hubs 10Q, 10B, 10C and joists 30A, 30B). The worker(s) can install new, or relocate, sections or units of the modular space frame support system 100 while the worker remains on existing sections of work platform 50. That is, additional lift equipment, machinery is not required to install, relocate, or remove the additional units or sections of a modular space frame support system when made using interconnection structures 10 and joists 30.

Further, the installing worker(s) need not extend beyond the existing installed frame unit 115 or, they need only extend barely beyond the installed frame unit 115. For example, as shown in FIG. 22, the installer(s) can be on the existing work platforms 50A, 50B, 50C, 50D when relocating, or installing, the next section(s) of the modular space frame support system 100.

As Figs. 23 through 25 clearly show via the motion arrows “M”, that by a combination of rotation of the new joists 30D, 30E, 30F and new interconnection structures 10D, 10E, that the new section or unit 115 of the modular space frame support system 100 is able to move and rotate into its final requisite location. That is, units of the modular space frame support system 100 articulate into place. Further, the articulation can be initiated and stopped (and even reversed) by an installer(s) while the installer(s) remains on the pre-existing frame units and/or work platform systems. Although not shown, additional supplemental devices to aid in the articulation (e.g., motors, hand tools, mechanical tools, hydraulics, etc.) can be used.

FIG. 26 shows a new section or units 115 of a modular space frame support system 100 articulated into place, prior to the installation of support platform(s) 50 and any other pieces, as discussed herein. The removal of a portion of the modular space frame support system 100 can essentially be done by reversing the aforementioned steps.

While the individual sections or units 115 of the modular space frame support system 100 (and, ultimately, work platform support system 200) described with reference to FIGS. 15-26 are square, that is, each individual section or unit 115 is made of four interconnection structures 10 and four joists 30, as mentioned above, in some embodiments the individual units 115 of the modular space frame support system 100 may take different geometries and shapes. For example, FIGS. 27A, 27B, 27C, and 27D show various embodiments of a joist 30 and interconnection

structure 10 configuration. For example, FIG. 27D shows a “standard” length joist 30A (e.g., 8 foot nominal length) with two interconnection structures 10A, 10B. This “standard” length joist 30A could be termed a “6/6 unit”. FIG. 27C shows two joists 30A, 30B of equal length connected to interconnection structures 10A, 10B, 10C. The joists 30A, 30B in FIG. 27C, being  
5 half the length, each of the length of the joist 30A in FIG. 20D, may be termed a “3/6 unit” in that they are half the length of the aforementioned “6/6 unit”. Similarly, two unequal length joists 30A, 30B are depicted in FIG. 27B, and can be termed a “2/6 unit” and a “4/6 unit”, respectively. This is because the “2/6 unit” is approximately one third the length of a “standard” “6/6 unit” joist as shown in FIG. 27D, as is the “4/6 unit” is approximately two thirds the length of the “6/6 unit”.  
10 The same system is shown in FIG. 27A, wherein the first joist 30A is termed a “1/6 unit” and the second joist 30B is termed a “5/6 unit”. As stated above, by using different lengths of joist 30, and by extending joists 30 from interconnection structures 10 at different angles, one can obtain a nearly infinite variety of configurations and footprints of the modular space frame support system 100 and resulting work platform system 200. This variety, for example, allows the installer to set  
15 up the modular space frame support system 100 and work platform system 200 around various obstacles (e.g., columns, piers, abutments, etc.) and structures. The variety allows the installer to create numerous shapes to the work platform system beyond just a rectangle.

With reference to the teachings herein, including at least Figures 14A, 17 and 22-26, it is apparent that at least one of the joists is to be connected with at least one of the interconnection  
20 structures using a pin to provide free rotation of the at least one joist with respect to the at least one interconnection structure about the pin. Moreover, it is apparent that the free rotation is restricted by at least one of: i) an additional pin that is to be located proximate a perimeter of the at least one interconnection structure; and ii) at least a portion of a work platform when the platform is positioned with respect to the interconnection structures and the joists in the final  
25 position.

FIGS. 28A and 28B depict the plan view of just two embodiments of the invention. In these figures it can be seen that the work platform support system 100 is capable of various horizontal alignments. For example, FIG. 28A shows 8 foot length joists 30 interconnected with a plurality of hubs 10. Due to spacing between the pin 40 and hub 10, some flexibility is provided in  
30 the system 100 so that the system 100 can be curved, or “racked”, in the horizontal direction. This can help allow the system 100 to be installed around structures. FIG. 28B depicts a system 100 that is angled. For example, the joists 30C connected to hub 10C, can be shorter than joists 30B connected to hub 10B. Joists 30B, in turn, are shorter than joists 30A, which are connected to hub 10A. In this fashion, by using joists 30A, 30B, 30C of different length and/or altering the angle

at which a joist 30 is connected to a hub 10, systems 100 that are angled, as in FIG. 28B can be configured. Similarly, this allows the system 100 to be installed, for example, around various impediments, structures, and the like.

FIG. 29 shows an elevation sectional view of one embodiment wherein a support system 100 and work platform system 120 are attached, via a suspension connector 80, to a structure 90. The structure 90 in this embodiment is a bridge 90. On the underside of the bridge 90 are a plurality of beams 92. A series of suspension connectors 80, in this embodiment high strength chains, are attached to several of the beams 92 via structure attachment device 82, in this embodiment standard beam clamps. At the perimeter of the work platform system 120 are a plurality of railing standards 85, thereby creating a railing system around the work platform system 120. The plurality of chains 80 are attached to various hubs 10 in the support system 100 thereby providing structural connection to the bridge 90. In this manner, a work platform system 120 and support system 100 can be fully suspended from a suitable structure 90. Note that each hub 10 does not necessarily require a suspension connector 80 to be connected to the structure 90. For example, there is no suspension connector 80 connecting hub 10X to beam 92X. This may be because hub 10A does not line up underneath beam 92X, or other suitable suspension point, and thus, using a chain 80 in that location is either not possible, or not desirable.

The suspension connector 80 may be any suitable support mechanism that can support both the work platform system 120, and all its ancillary dead loads, plus any intended live load that is placed upon the work platform system 120. In fact, the work platform system 120 may support its own weight plus at least four times the intended live load that is to be placed on the work platform system 120. Similarly, the suspension connector 80 is also suitable to support its own weight plus at least four times the intended live load placed on it. The suspension connector 80 may be a high-strength chain, cable, or the like. For example, one suitable suspension connector 80 is  $\frac{3}{8}$ " grade 100, heat-treated alloy chain.

The suspension connector 80 is attached to a beam clamp 82 which is further attached to a plurality of elements 92 on the underside of a structure 90. The structure 90 may be a bridge, viaduct, ceiling structure of a building, or the like. Similarly, the elements 92 which the suspension connector 80 are attached to may be beams, joists, or any other suitable structural element of the structure 90. Instead of beam clamps 82, other suitable structure attachment devices 82 may be used.

FIGS. 30A, 30B, 31A, 31B all depict various views of the interconnection between the suspension connector 80 (e.g., chain, cable, etc.) and the hub 10. In the embodiment shown, a

free end of the chain 80 (i.e., end distal to structure 90) is placed through the center opening area 19 of the top element 11 of the hub 10. The chain 80 is then slid over and in to one of the four slots 17 (e.g., 17A). Once the chain 80 is placed within slot 17A, a chain retainer pin 200 is placed in the adjacent transverse slot 18A so that the chain 80 is kept retained in the distal end of slot 17A. The chain 80 and slot 17A are sized and configured so that upon proper placement of the keeper pin 200 within the transverse slot 18A, the chain 80 is effectively locked to the hub 10 and is unable to slip, vertically or horizontally, from its position in 17A. This locking system effectively fixes the hub 10 to the chain 80. As an added safety check, a zip tie 201 may be placed between a hole 202 in the chain retainer pin 200 and an adjacent link in the chain 80. This further provides a visual aid to the installer to ensure that the chain retainer pin 200 has been installed.

An alternative device for connecting a suspension connector 80 to the work platform support system 100 is an auxiliary suspender mounting bracket 300. The auxiliary mounting bracket 300 is typically used when a particular hub 10 cannot be accessed for connection with a suspension connector 80. As the various FIGS. 32A, 32B, 32C, and 32D depict, one embodiment of the auxiliary suspender mounting bracket 300 includes two opposing and parallel flanges 303. Spanning the flanges 303 is an interconnecting tube 304 and a base plate 302. Through the base plate 302 are a plurality of mounting holes 305. The auxiliary suspender mounting bracket 300 can be used in lieu of, or in addition to, the hub 10 for a suspension point. The bracket 300 allows a suspension connector 80 to be connected to the system 100 at locations other than a hub 10.

For example, FIG. 33 depicts a scenario that may typically be encountered when installing a work platform system 120. Note that FIG. 33 is not drawn to scale. One or more obstructions 95A may be located on the underside of the structure 90, or between the structure 90 and the work platform system 120. These obstruction(s) 95A may be man-made, or natural. For example, the obstructions 95A may be concrete beams, box-beams, inadequately sized framework, ductwork, lighting, finished surfaces, and the like. The obstructions 95A are such that a particular hub 10B is not practical, or possible, as a connecting point for the system 120 to a suspension connector 80. In this case, one or more auxiliary suspender mounting brackets 300 may be attached to a joist 30. High strength bolts (not shown) may be passed through the mounting holes 305 and then through holes on an upper element 32 and connected to bolts below the upper element 32. (See for similar connection detail the connection of plate 60 in FIG. 19B). The suspension connector 80 (e.g., chain) may be connected, via a beam clamp 82, to a beam 92 that is on the underside of the structure 90.

As shown in FIG. 33, obstruction 95B is directly vertically over hub 10B, thereby rendering hub 10B inadequate for a suspension point. Thus, a bracket 300 can be attached to a joist 30 adjacent to hub 10B, thereby allowing a suspension connector 80 to get proper attachment to a nearby beam 92. The angle,  $\Phi$ , between the suspension connector 80 and vertical, denoted by  $V$ , allows for the suspension connector 80 to be either non-vertical, or slightly off of vertical.

FIGS. 34A, 34B, and 34C show elevation views of various embodiments wherein the vertical flexibility of the present invention is apparent. For example, FIG. 34A shows a portion of a work platform system 120 suspended from the non-flat underside of a structure 90 (e.g., arched bridge). The suspension connector 80 and other connection details are not shown for ease of illustration. There is flexibility, due to the design, in the interconnections between hub 10 and joist 30. This flexibility allows for some bendability in the vertical direction (See e.g., FIG. 34A). This allows the system 120, for example, to parallel, or “mirror”, the underside of a curved, arched bridge.

Alternatively, should the curvature of the supporting structure 90 be even greater, a configuration such as shown in FIG. 34B can be installed. That is multiple portions of the system 120 are not co-planar, but rather stepped, or tiered. If required, various suspension connectors 80 may be installed of such length so that multiple hubs 10A, 10B may be installed to the same suspension connector 80. As discussed above, the suspension connector 80 may be connected to a slot 17 of the upper hub 10A, then passed through the bottom opening 23 of the upper hub 10A and then connected also to a slot 17 of the lower hub 10B (See e.g., FIGS. 30A, 30B).

As FIG. 34C shows another configuration of the present invention is the capability to install the system 120 in a multi-level configuration. For example, where work perhaps needs to be done on a vertical structure 99 (e.g., bridge pier), at least two systems 120A, 120B may be installed. Similar to the connection scenario used in FIG. 34B (above), suspension connector 80 can, again, be of suitable length so as to pass from hubs 10A on the upper system 120 on to, and also connect up to, the hubs 10B on the lower system 120. In this manner, multiple levels of system 120 may be installed in a vertical orientation.

### *Suspension Scaffold*

In the embodiments shown herein, a further scaffold system 800 is shown in use as a monorail car which is moveably attached to the monorail assemblies 600, and the further scaffold system is a suspension scaffold system. FIG. 35 illustrates an exemplary suspension scaffold system. It will be appreciated, however, that in further embodiments, the monorail car 800 may be

made of any form of scaffolding system, and preferably any form of suspended scaffold system, including a suspended articulating scaffold system as described above. Further, a “further scaffold system,” “second scaffold system,” and “monorail car” may be used interchangeably herein.

In the embodiment shown in FIG. 35, the suspension scaffold system **800** has a platform **810** formed from a frame **815** which supports flooring **820**. A series of braced railing members at least partially surround the platform.

#### Additional Components

The scaffold systems **100, 800** used in combination with monorail assemblies of the present disclosure may include further additional components.

For example, in some embodiments, railings, toe boards, tarps, sheets, gates, ladders, doors/doorways, wheels, bumpers, and other accessories may be used in combination with any scaffold system disclosed herein.

#### Monorail System

Referring again to FIGS. 1A and 1B, as well as FIGS. 36-46, shown are multiple embodiments of monorail systems **700**. Each monorail system **700** includes a first scaffold system **100**, a monorail assembly **600** connected to the first scaffold system **100**, and a monorail car **800** made of a second scaffold system. Specifically, in the embodiment shown in FIGS. 1A, 1B and 36-46 there are three monorail systems **700**. A first monorail system **700a** includes a single monorail assembly **600a** connected to the scaffold system **100a** with a single monorail car **800a** positioned on the outside of the structure **90**. A second monorail system **700b** is located on the opposite side of the structure **90** and includes a single monorail assembly **600b** connected to the scaffold system **100b** with a single monorail car **800b** positioned outside the structure **90**. A third monorail system **700c** includes two monorail assemblies **600c, 600d** connected to scaffold system **100a** and **100b**, respectively, with a single monorail car **800c** extending under the structure **90** with a first end of the monorail car **800c** operatively coupled with the first monorail assembly **600c** and a second end of the monorail car **800c** operatively coupled with the second monorail assembly **600d**.

Generators **720** located on the structure **90** or otherwise apart from the monorail systems **700** provide power to the monorail cars **800** to effectuate their movement both along the respective monorail(s) and vertically.

The monorail systems **700a, 700b, 700c** will now be explained in further detail.

FIG. 36 is a detailed view of callout 7 of FIG. 1A and again shows the connection of monorail beams **630** to each other and to a scaffold system **100**.

FIG. 37 is a cross-sectional view taken from A-A of FIG. 1A and illustrates the third monorail system **700c**. In the embodiment shown, two scaffold systems **100a**, **100b** are provided. Each scaffold system **100a**, **100b** is shown as a suspended articulating scaffold system as described above and made of a plurality of interconnection structures **10** and joists **30**. The scaffold systems **100a**, **100b** are connected to the structure both from above so as to be suspended from the structure **90** and at the side closest to the structure **90**.

FIG. 39 is a detailed view of callout 2 of FIG. 37 and shows the connection of the scaffold system **100** to the structure **90** above. Specifically, a concrete anchor **830**, such as a threaded rod, is inserted into the underside of the structure **90**. A rotating suspension point, such as that described in co-pending application [to be filed in before filing] receives the chain **835** which connects to the interconnection structure **10** or other portion of the scaffold system **100**, as described in detail above with respect to FIGS. 29-32D. FIG. 40 is a detailed view of callout 3 of FIG. 37 and illustrates such an exemplary connection.

FIGS. 41 and 42 illustrate exemplary connections between the scaffold systems **100a**, **100b** to the side of the structure **90**. As shown in FIG. 41, depending on the direction of anticipated wind forces, if any, an adjustable tube **872** having a foot **873** at its end may be used to push against the structure **90** and prevent movement of the scaffold system **100** towards the structure **90**. The adjustable tube **872** is secured to an interconnection structure **10** of the scaffold system **100**. As shown in FIG. 42, to prevent movement of the scaffold system **100** away from the structure **90**, a chain **876** may be connected to the interconnection structure **10** and wrapped around a portion of the structure **90** such as a column or post.

The monorail car **800** spans the width of the underside of the structure **90** to permit access to the undersurface **91c**. In the embodiment shown, the monorail car **800** is made of suspension scaffolding as described above. At either end of the monorail car **800** is a hoist motor **801** to effectuate movement of the monorail car **800** in a vertical direction, that is, up and down in relation to the structure.

FIG. 46 is a cross-sectional view taken from C-C of FIG. 44 and illustrates the mechanisms which permit movement of the monorail car **800c** both along the monorail beams **630** and vertically in further detail.

The structures and devices used to move scaffolding along a rail, and power and control that movement, are known in the art. Generally, such a structure and/or device includes a plurality of wheels which engage the lower flanges **632** of the monorail beam **630**. The movement of the structures and/or devices along that monorail beam **630** is control and actuated using power from the one or more generators **720**. In particular, as shown in FIGS. 44-45, two trolley structures **727**,

728 are provided on each monorail assembly. One of the trolley structures 728 is passive and just facilitates travel along the monorail beam 630. The other of the trolley structures 727 is active, that is, has power and is connected to controls, to facilitate movement of the monorail car 800c along the monorail beams 630.

5 It will be appreciated that, in permitting both vertical movement and movement along the monorail beams, workers on the monorail car 800 are able to access substantially the entire undersurface 91c of the structure 90.

FIG. 38 is a cross-sectional view taken from B-B of FIG. 1A and illustrates the first and second monorail systems 700a, 700b. The first and second monorail system 700a, 700b also  
10 utilize the two scaffold systems 100a, 100b. As opposed to the embodiments shown in FIG. 37, the embodiments shown in FIG. 38 illustrate an additional means of providing stability of the scaffold systems 100a, 100b relative to the structure 90. The callouts shown in FIGS. 41 and 42 illustrated additional means of securing the scaffold system 100 to the structure 90 in view of lateral forces. FIG. 43 is a detailed view of callout 6 of FIG. 38 and illustrates a stabilizing means  
15 in view of vertical forces, e.g., updraft. As shown in FIG. 43, a third scaffold system (such as a standard scaffold system) is erected on the scaffold system 100 and extends between the scaffold system 100 and the bottom of the structure 90 to prevent upward movement of the scaffold system 100.

Each monorail system 700a, 700b includes a monorail car 800a, 800b. While the  
20 embodiment shown in FIG. 37 includes a single monorail car 800c connected to two monorail assemblies, the monorail cars 800a, 800b shown in FIG. 38 are each connected to just a single monorail assembly at two points. Like monorail car 800c, the monorail cars 800a, 800b are made of suspension scaffolding as described above. At either end of the monorail cars 800a, 800b is a hoist motor 801 to effectuate movement of the respective monorail car 800a, 800b in a vertical  
25 direction, that is, up and down in relation to the structure.

FIGS. 44 and 45 illustrate an exemplary monorail car such as 800a, 800b. With reference to FIGS. 44 and 45, the description will make reference to monorail car 800a for simplicity, with the understanding the same description will apply to monorail car 800b.

The structures and devices used to move scaffolding along a rail, and power and control  
30 that movement, are known in the art. Generally, such a structure and/or device includes a plurality of wheels which engage the lower flanges 632 of the monorail beam 630. The movement of the structures and/or devices along that monorail beam 630 is control and actuated using power from the one or more generators 720. In particular, as shown in FIGS. 44-45, two trolley structures 727, 728 are provided. One of the trolley structures 728 is passive and just facilitates travel along the

monorail beam **630**. The other of the trolley structures **727** is active, that is, has power and is connected to controls, to facilitate movement of the monorail car **800a** along the monorail beams **630**.

5 It will be appreciated that, in permitting both vertical movement and movement along the monorail beams, workers on the monorail cars **800a**, **800b** are able to access substantially the entirety of the side surfaces **91a**, **91b** of the structure **90**.

FIG. 47 is a cross-sectional view taken from D-D of FIG. 1A and illustrates an exemplary cable configuration to get power from the generator(s) to the hoist motors and power trolleys.

#### Method of Accessing a Surface

10 When accessing a surface using a monorail system as described herein, it is possible to access surfaces previously inaccessible (or not easily accessible) and do so without assembling numerous levels and lengths of scaffolding.

Generally, a first scaffold system is assembled and suspended from the structure to be accessed. A monorail assembly is attached to the first scaffold system as needed to permit access  
15 to the structure. A monorail car is then built of a second scaffold system and suspended from the monorail assembly using at least one powered trolley to permit lateral movement of the monorail car parallel with the monorail beams. The monorail car also includes at least one hoist which permits vertical movement of the monorail car.

In an embodiment, the first scaffold system is a suspended articulating scaffold system.  
20 When using a suspended articulating scaffold system as disclosed herein, it is possible to assemble the first scaffold system in the air off of an existing structure, such as detailed with reference to FIGS. 22-26. The first scaffold system is also secured and suspended from the structure as described with further reference to FIGS. 29-33 and 39-42.

Once the first scaffold system is assembled and secured, the monorail assembly or  
25 assemblies are attached to the first scaffold system. First, the location of the monorail beams must be determined in order to position the joist brackets in the appropriate locations. The joist brackets are then secured to the first scaffold system, and specifically, in embodiments in which the first scaffold system is a suspended articulating scaffold system, to the joists of the first scaffold system, as described with reference to FIGS. 3A-3C. Monorail beams (which are fitted with joining  
30 bracket assembly s) are secured to each other and the first scaffold system using the joining bracket assembly s and joist brackets, as described with reference to FIGS. 5A-5E and 7A-7F. An end stop is put on both terminal ends of the monorail assembly in accordance with the description provided with respect to FIGS. 6A-7F.

A monorail car is assembled using a second scaffold system, such as, for example, a suspension scaffold as described herein. The monorail car is suspended from the monorail beam using at least one power trolley, and preferably at least one power trolley and one passive trolley.

5 In some embodiments, such as shown with reference to FIG. 37, it may be desirable to use two monorail assemblies with a single monorail car. In that case, two first scaffold systems are assembled at a distance away from one another with a plurality of scaffold frame members, or joists, in each system being parallel to one another. If scaffold frame members, or joists, in one of the first scaffold systems are not parallel with scaffold frame members, or joists, in the other of the first scaffold system, it will be difficult, if not impossible, to create two parallel monorail  
10 assemblies.

A monorail car is assembled as described above, and secured to both first scaffold systems using at least one power trolley and at least one passive trolley with each first scaffold system.

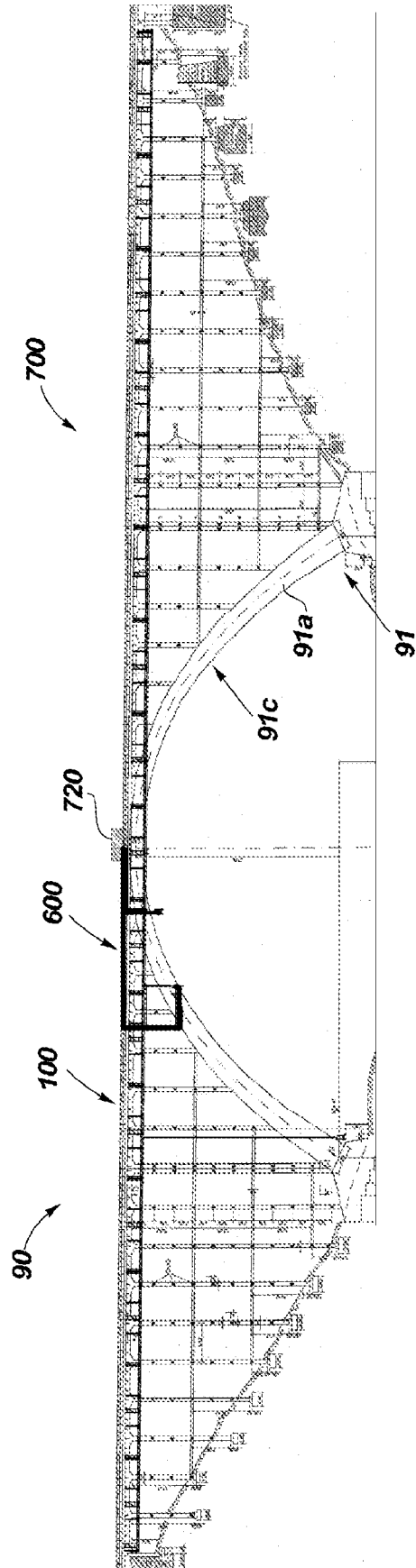
Thus, it is specifically intended that the present disclosure not be limited to the embodiments and illustrations contained herein, but include modified forms of those embodiments including  
15 portions of the embodiments and combinations of elements of different embodiments as come within the scope of the following claims.

## CLAIMS:

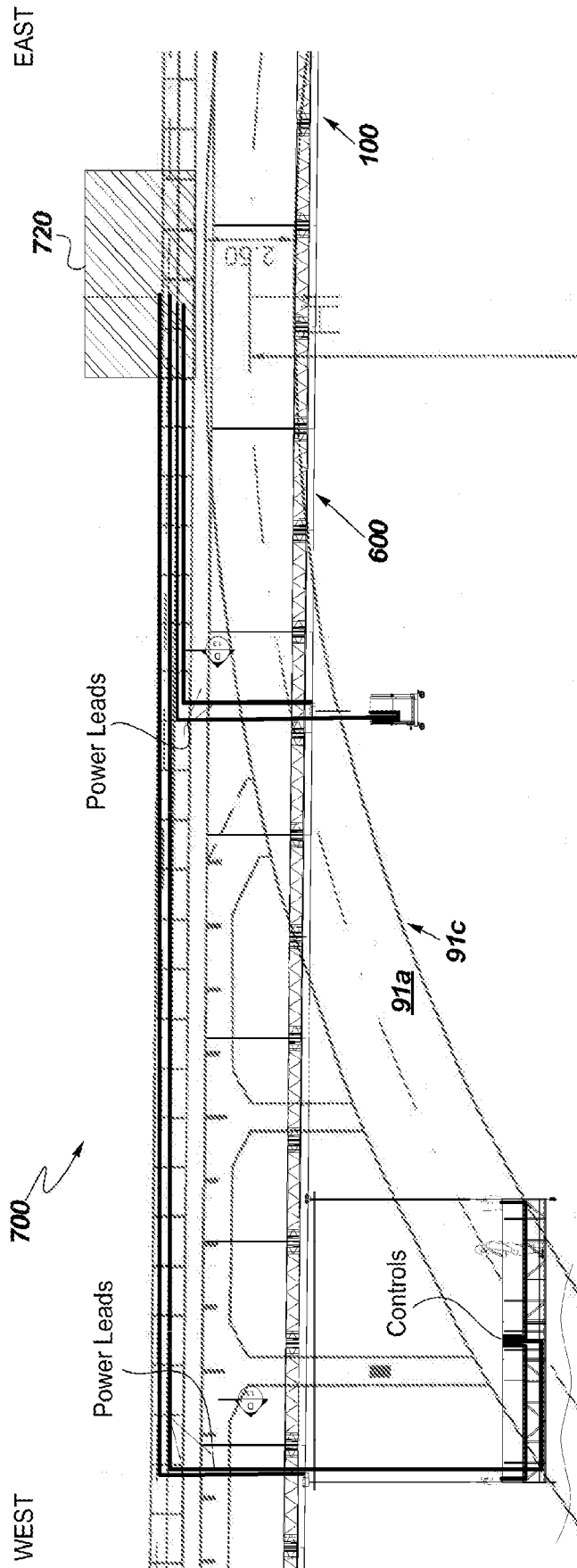
1. A monorail assembly comprising:
  - a first scaffold system comprising at least one framework member being an elongated structure having a bottom chord and a plurality of panel points along the bottom chord;
  - 5 at least one monorail beam; and
  - at least one bracket structure configured to secure to the at least one framework member at or about at least two panel points and to the at least one monorail beam.
  
2. The monorail assembly of claim 1, wherein the at least one monorail beam does not contact  
10 the at least one framework member when secured to the at least one bracket structure.
  
3. The monorail assembly of any of claims 1-2, further comprising at least one joist bracket which is connected to the at least one monorail beam and the at least one bracket structure.
  
- 15 4. The monorail assembly of claim 2, further comprising at least one joist bracket and wherein the connection of the at least one monorail beam to the at least one framework member is accomplished by the connection of the at least one joist bracket and at least one bracket structure.
  
5. The monorail assembly of any of claims 1-4, further comprising at least one end stop  
20 secured to the at least one monorail beam.
  
6. The monorail assembly of any of claims 1-5, further comprising at least two trolley structures slidingly secured to the first scaffold system and configured to secure a second scaffold system.  
25
  
7. The monorail assembly of any of claims 1-6, wherein the at least two trolley structures are slidingly secured to the at least one elongated structure.
  
8. The monorail assembly of any of claims 1-6, wherein the first scaffold system comprises  
30 at least two framework members.

9. A monorail system comprising:  
a first scaffold system;  
a monorail assembly secured to the first scaffold system and comprising at least one monorail beam; and
- 5 a second scaffold system suspended from the at least one monorail beam.
10. The monorail system of claim 9, wherein the second scaffold system moves both laterally along the at least one monorail beam and vertically with respect to the at least one monorail beam.
- 10 11. The monorail system of any of claims 9-10, wherein the first scaffold system is a suspended articulating scaffold system.
12. The monorail system of any of claims 9-11, wherein the monorail assembly further comprises at least one bracket structure configured to secure to the first scaffold system.
- 15 13. The monorail system of any of claims 9-12, wherein the second scaffold system is a monorail car.
14. The monorail system of any of claims 9-12, wherein the second scaffold system is a
- 20 suspension scaffold.
15. The monorail system of any of claims 9-14, further comprising at least two trolley structures slidingly secured to the first scaffold system.

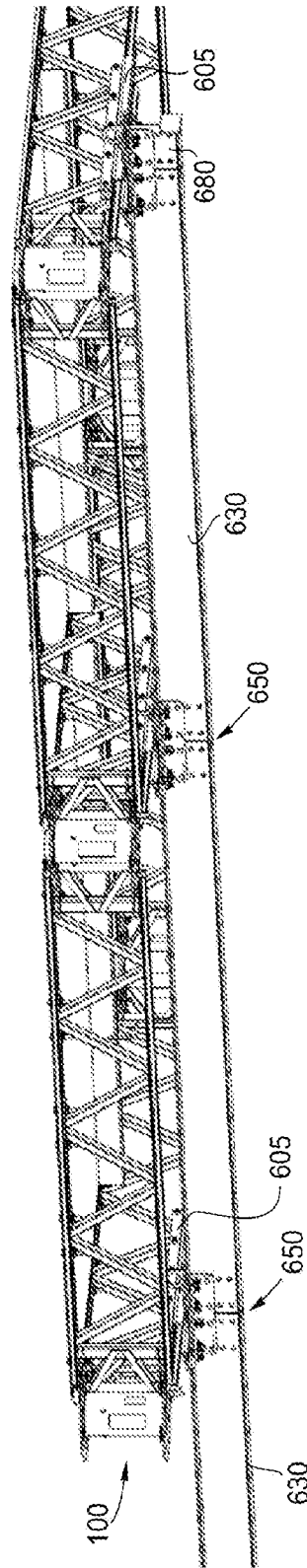
**FIG. 1A**

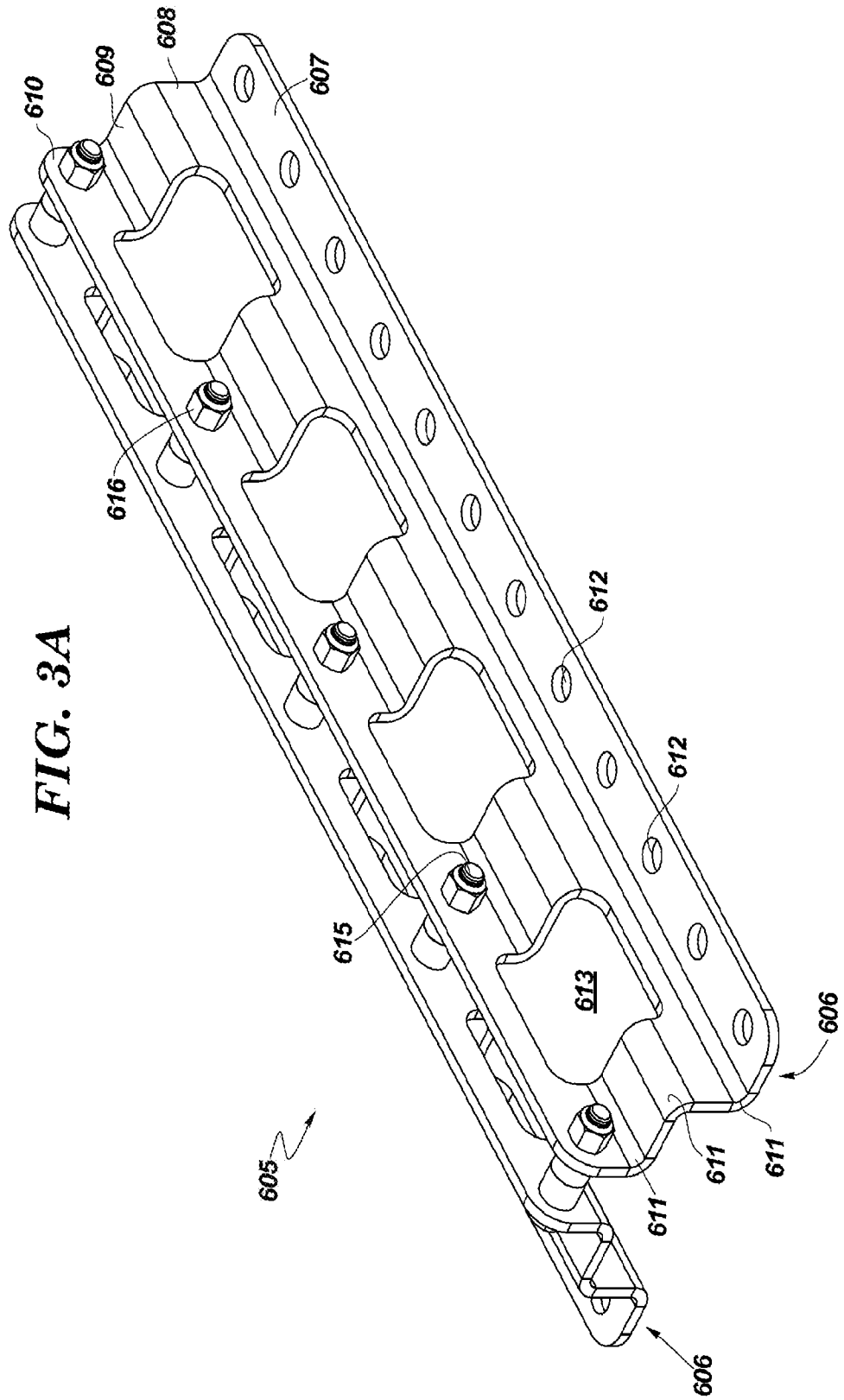


**FIG. 1B**



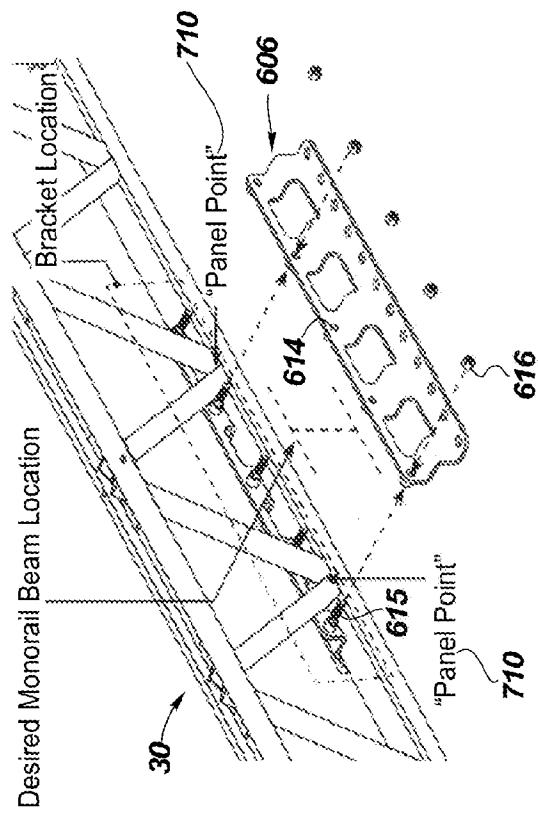
**FIG. 2**



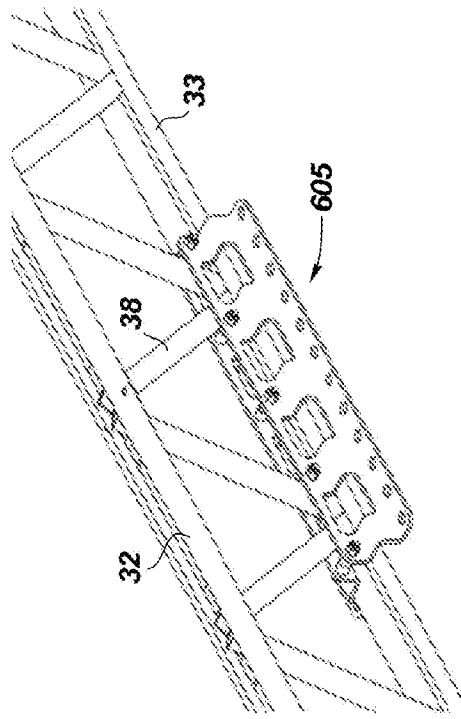


**FIG. 3A**

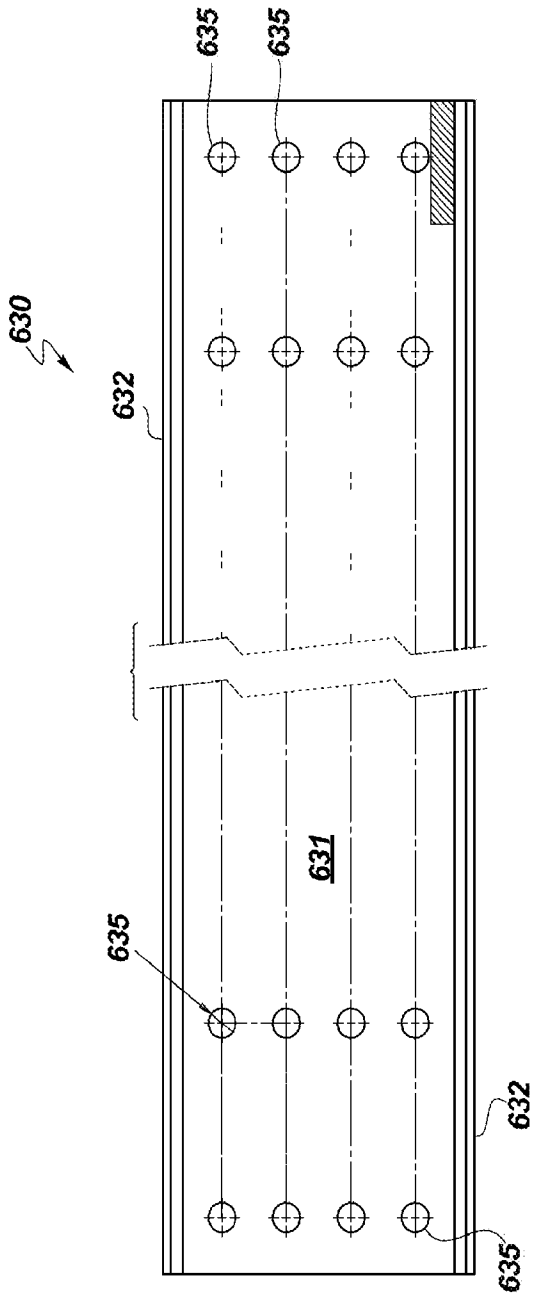
**FIG. 3B**



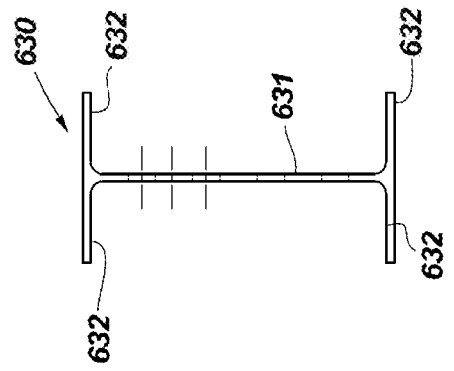
**FIG. 3C**

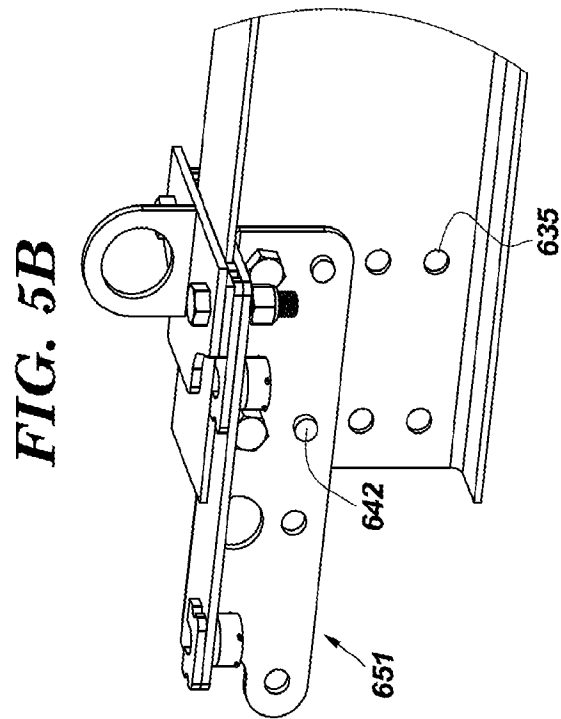
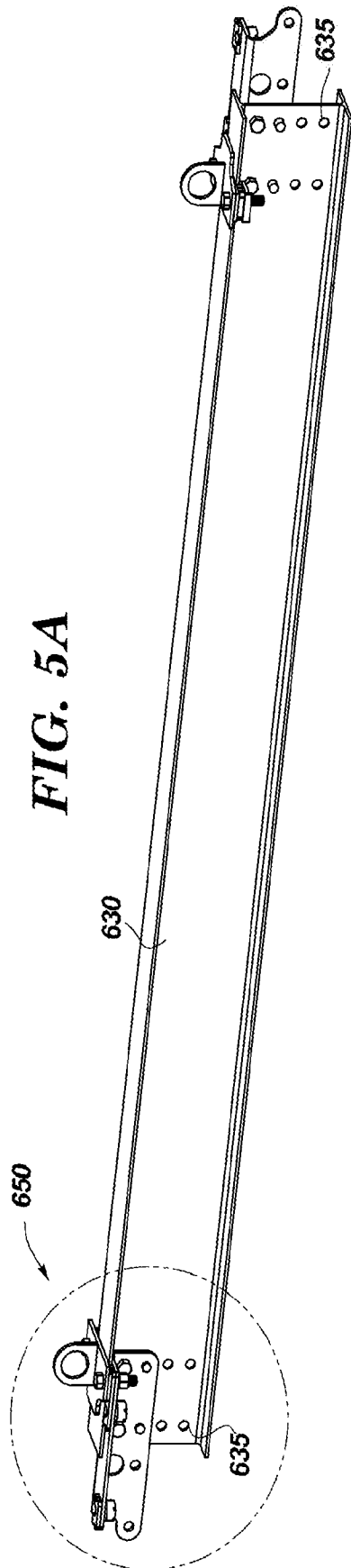


**FIG. 4A**

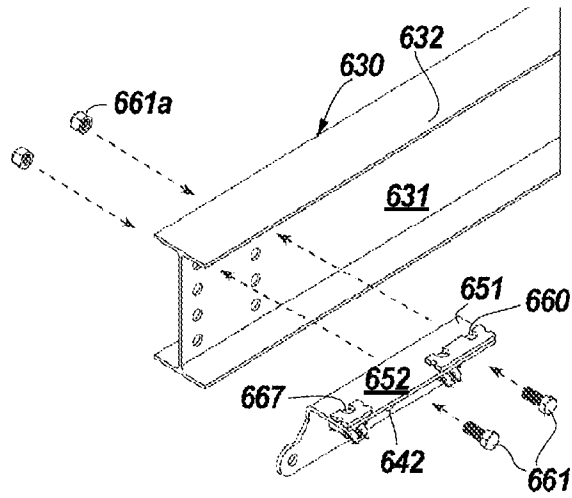


**FIG. 4B**

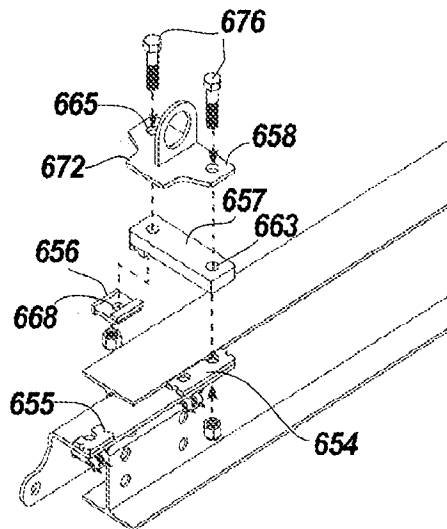




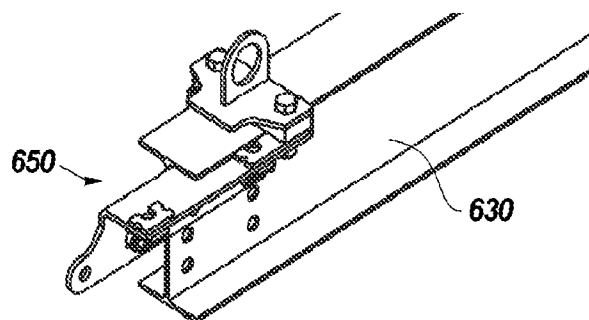
**FIG. 5C**



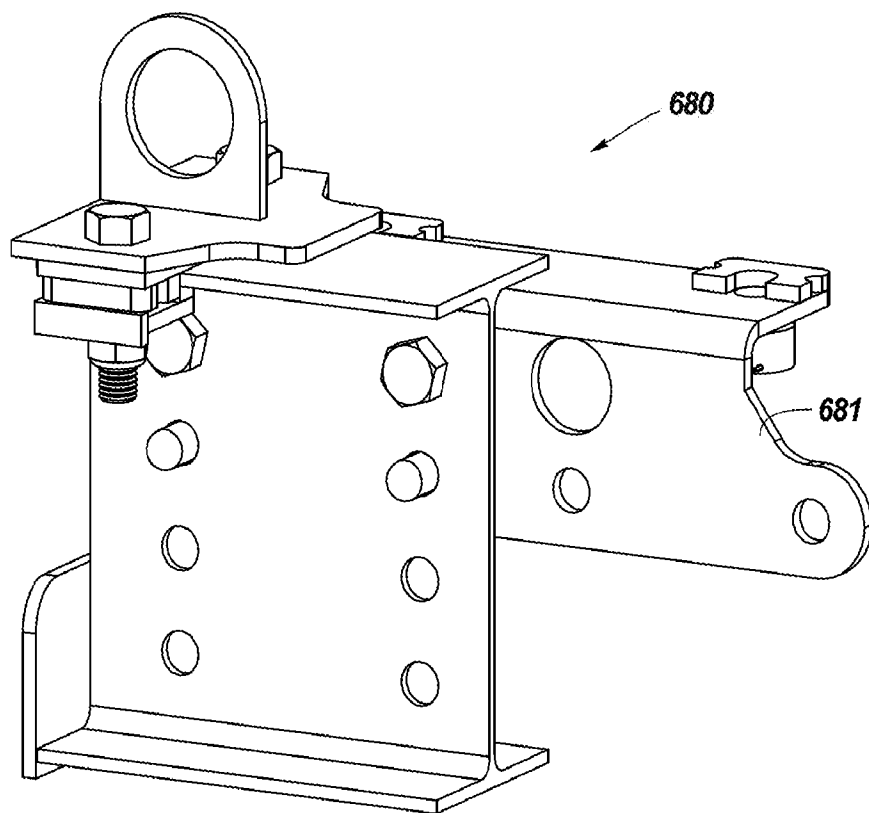
**FIG. 5D**



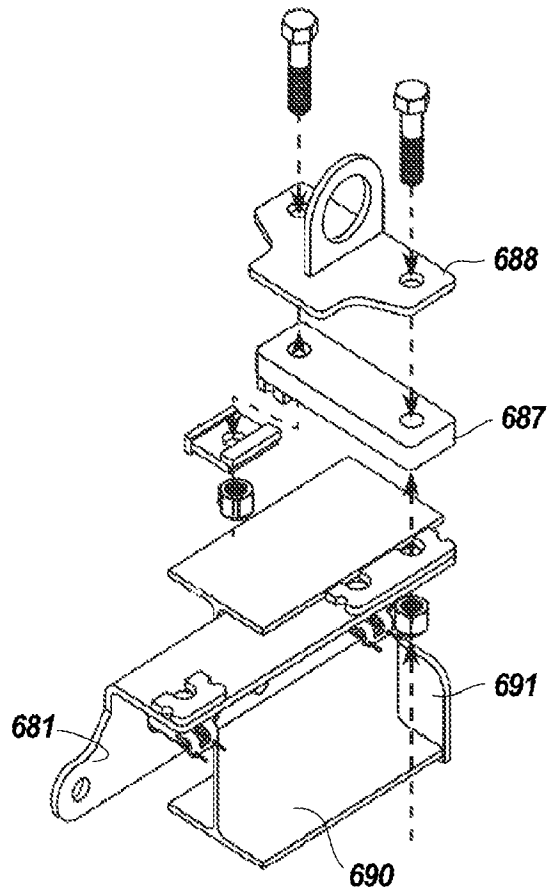
**FIG. 5E**



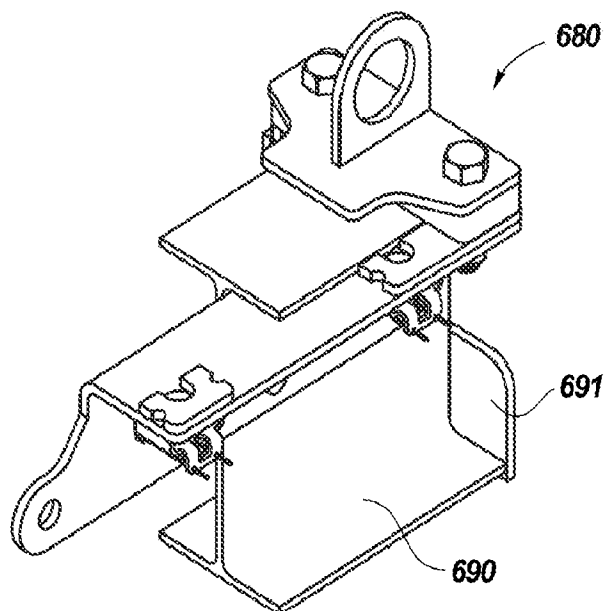
**FIG. 6A**



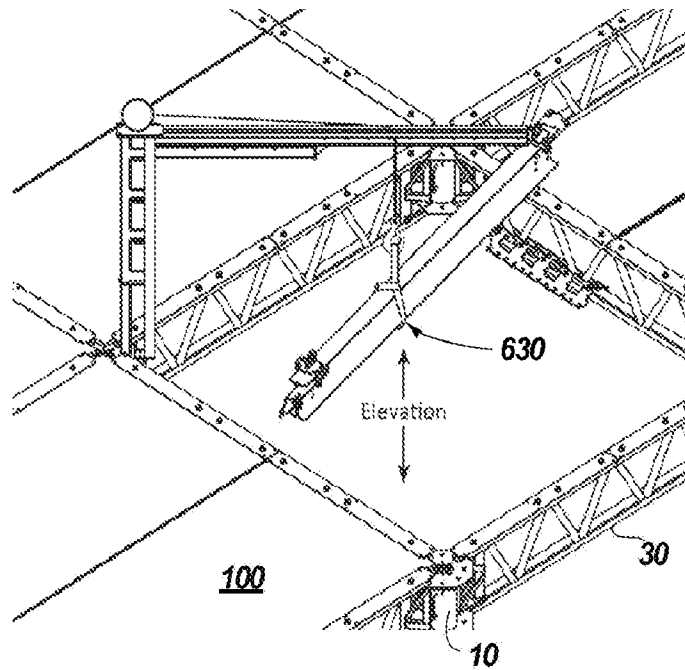
**FIG. 6B**



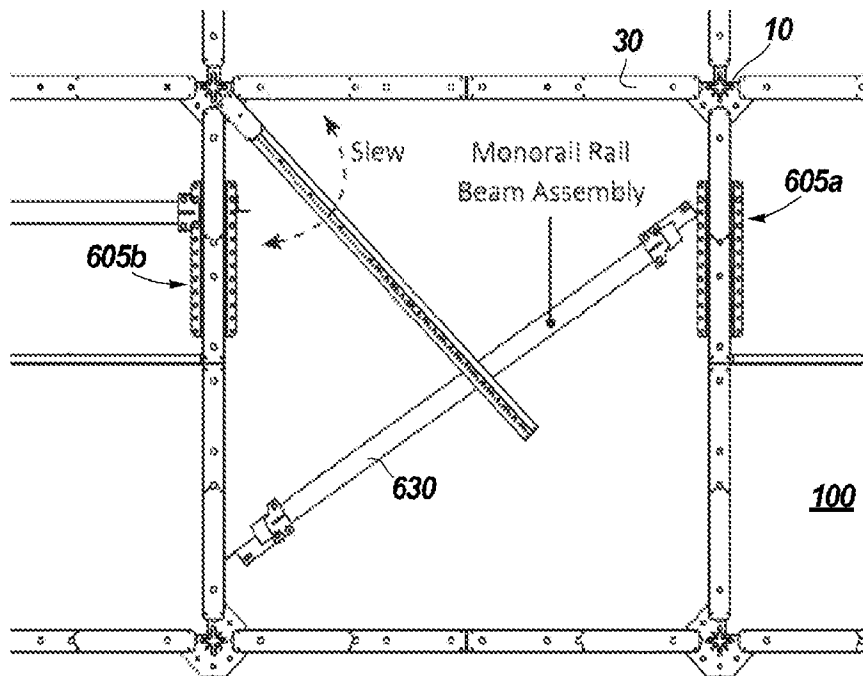
**FIG. 6C**



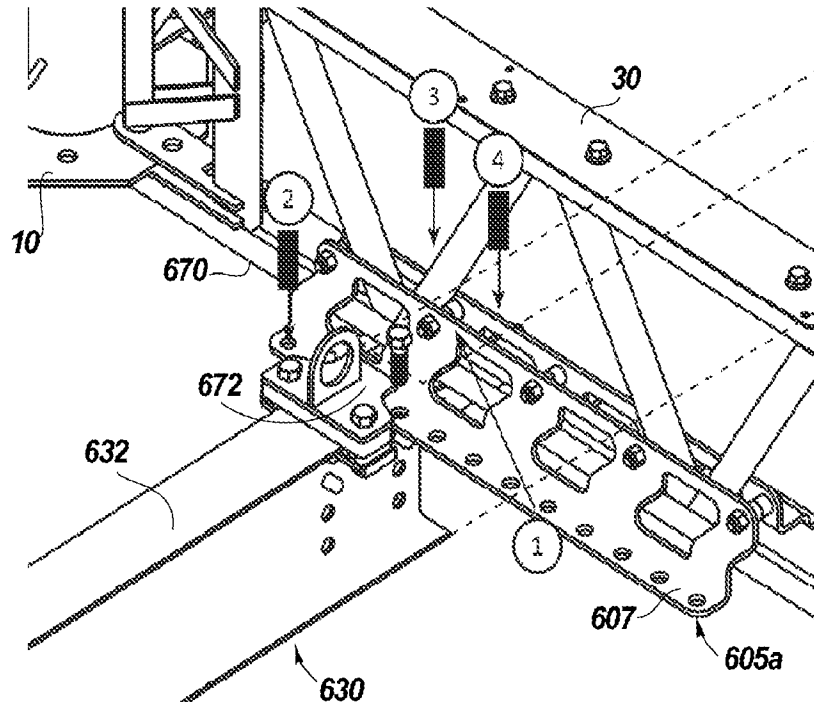
**FIG. 7A**



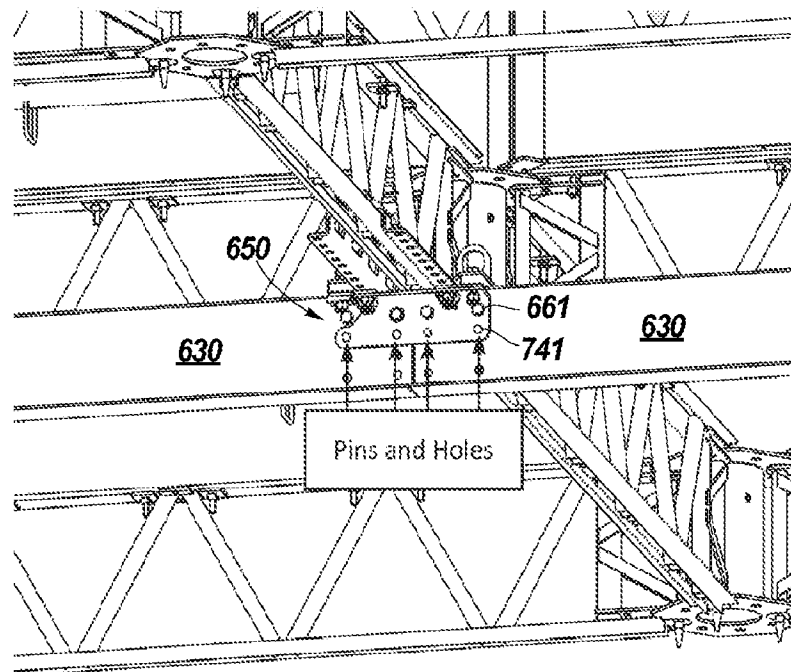
**FIG. 7B**



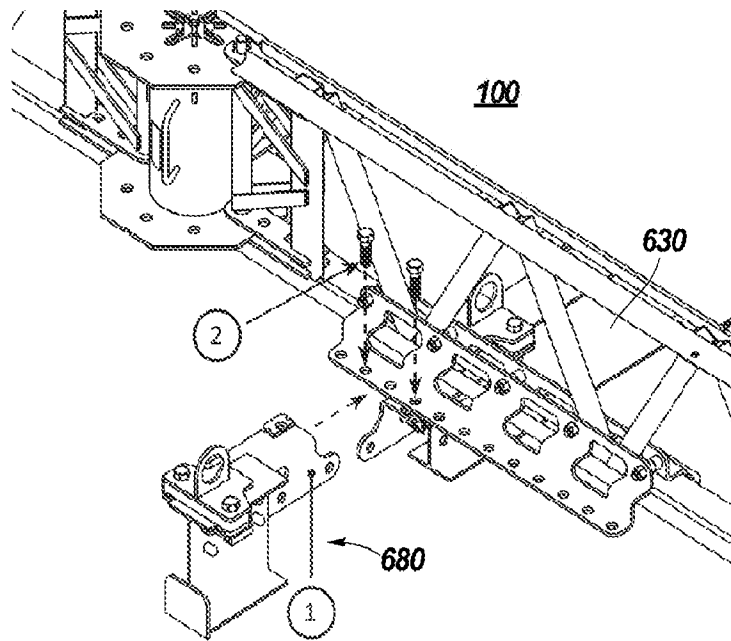
**FIG. 7C**



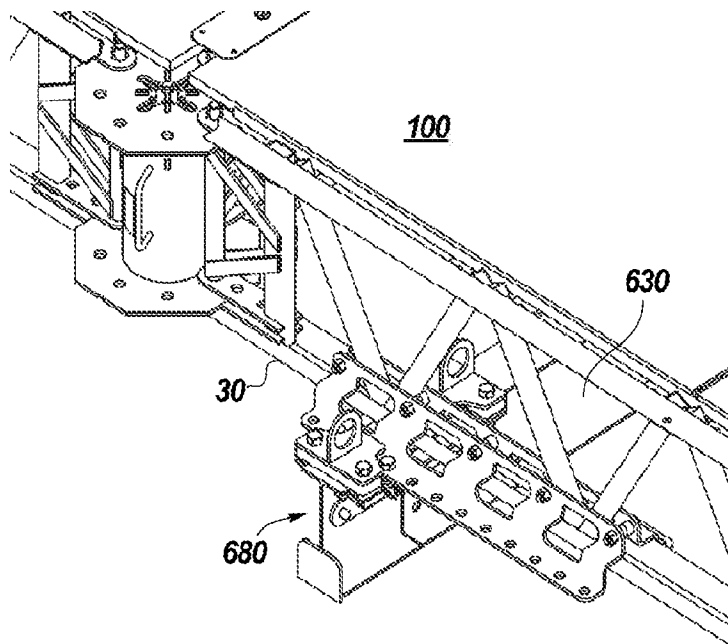
**FIG. 7D**

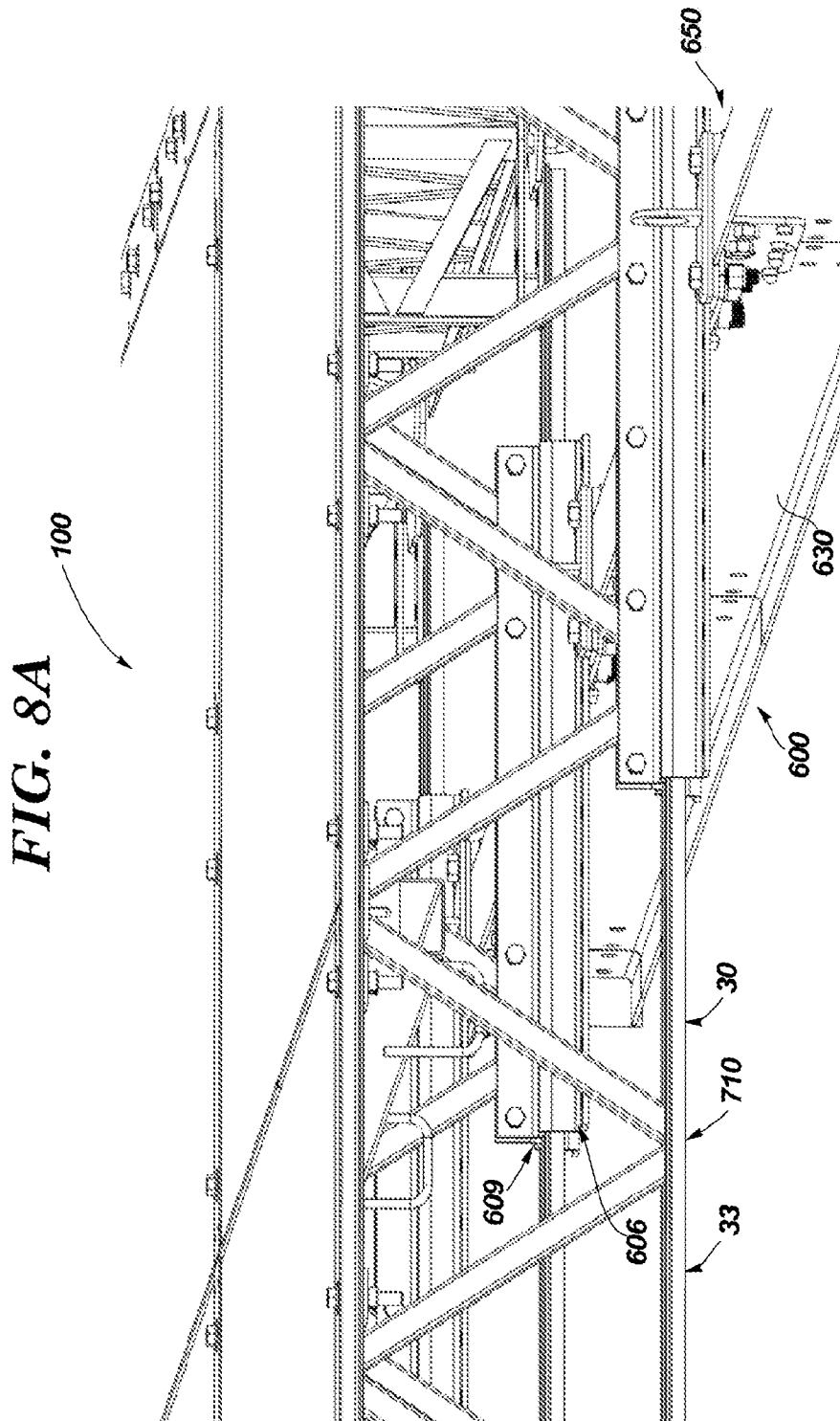


**FIG. 7E**

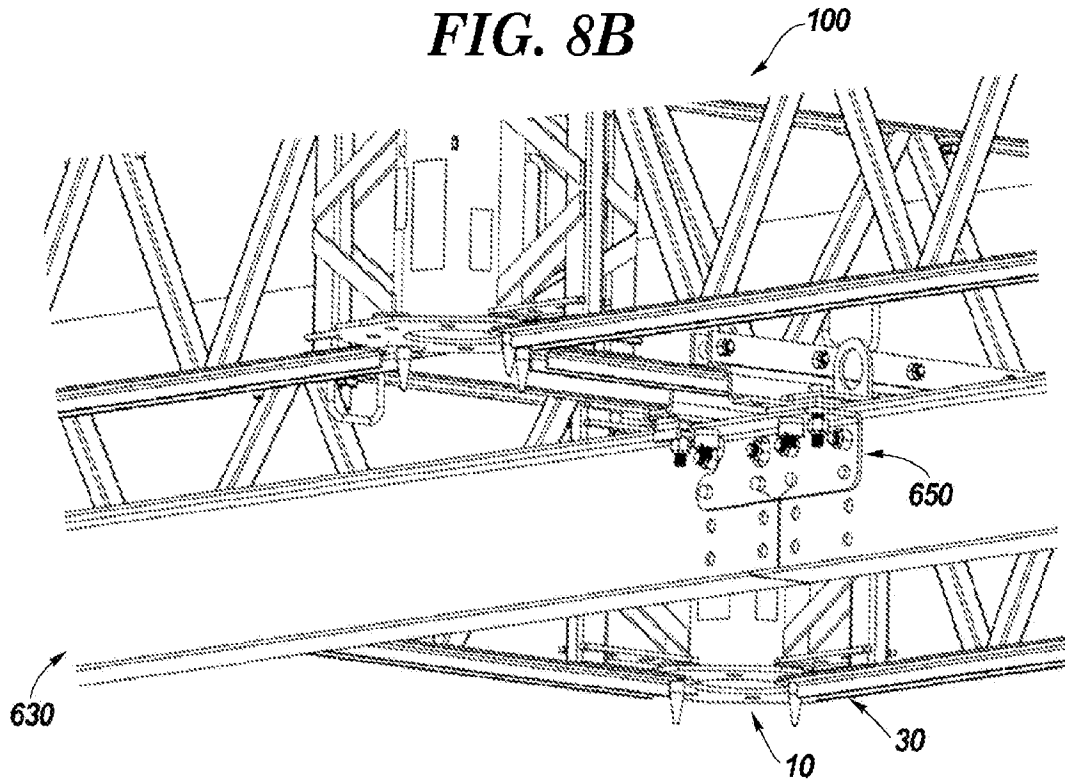


**FIG. 7F**





**FIG. 8B**



**FIG. 8C**

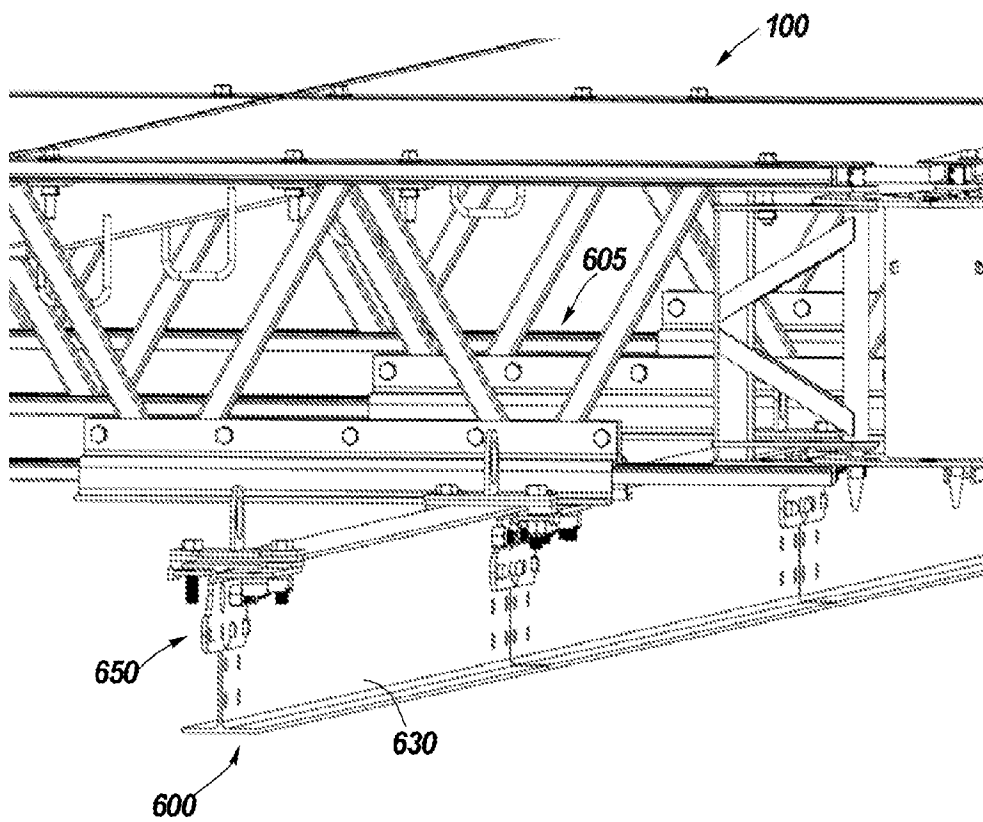
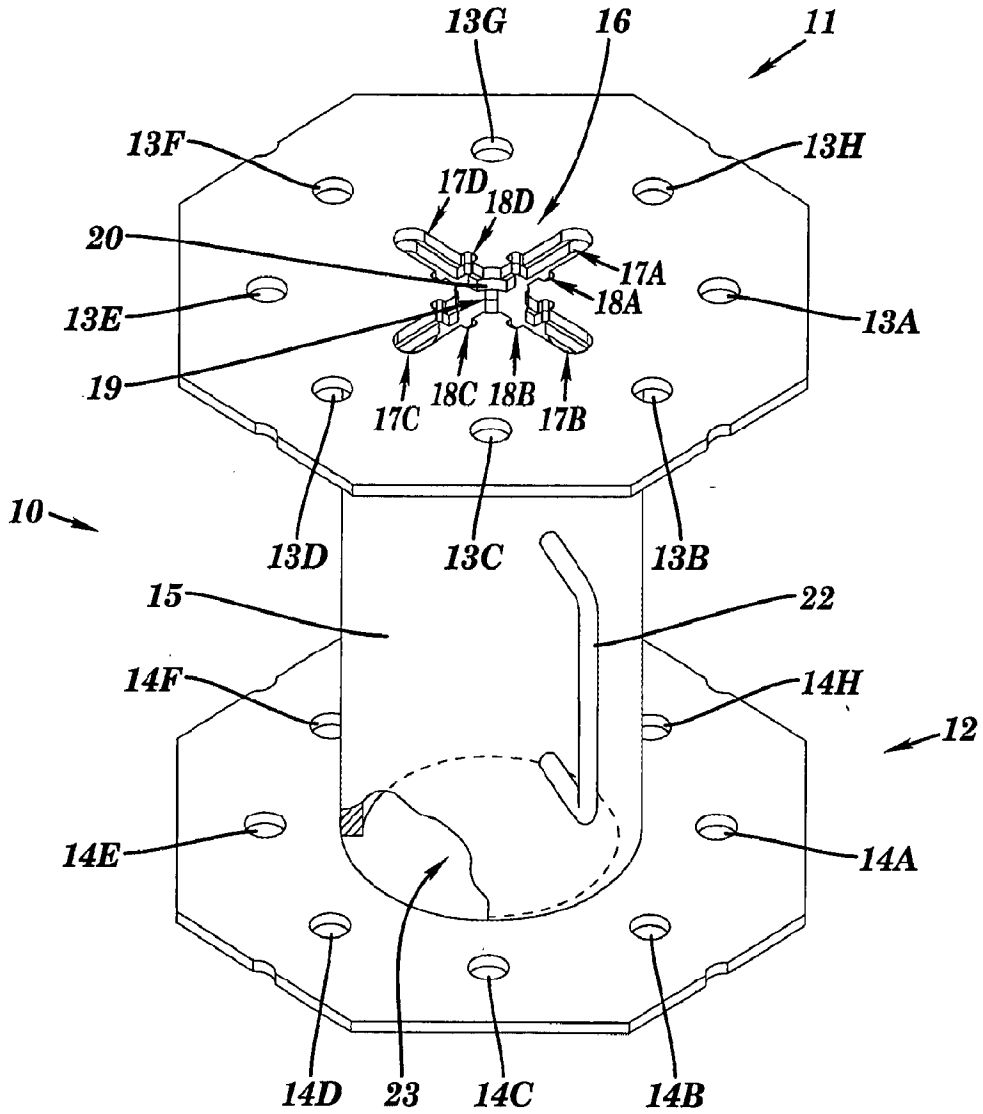
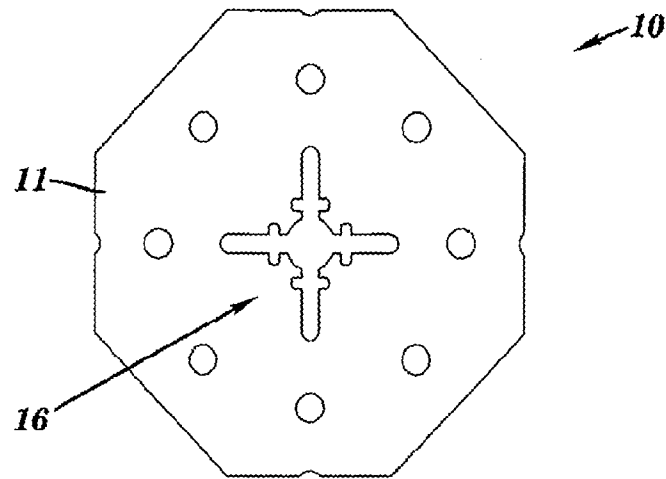


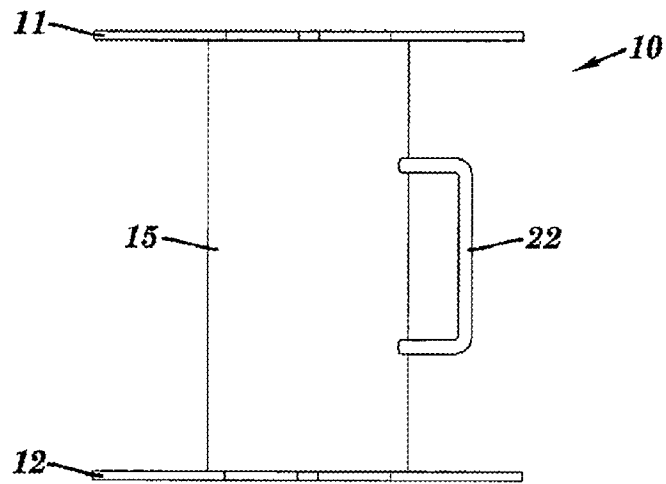
FIG. 9



**FIG. 10**



**FIG. 11**



**FIG. 12**

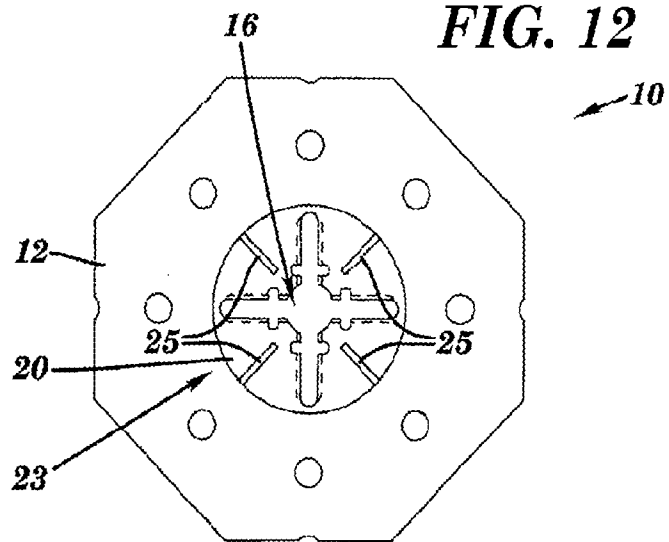




FIG. 14A

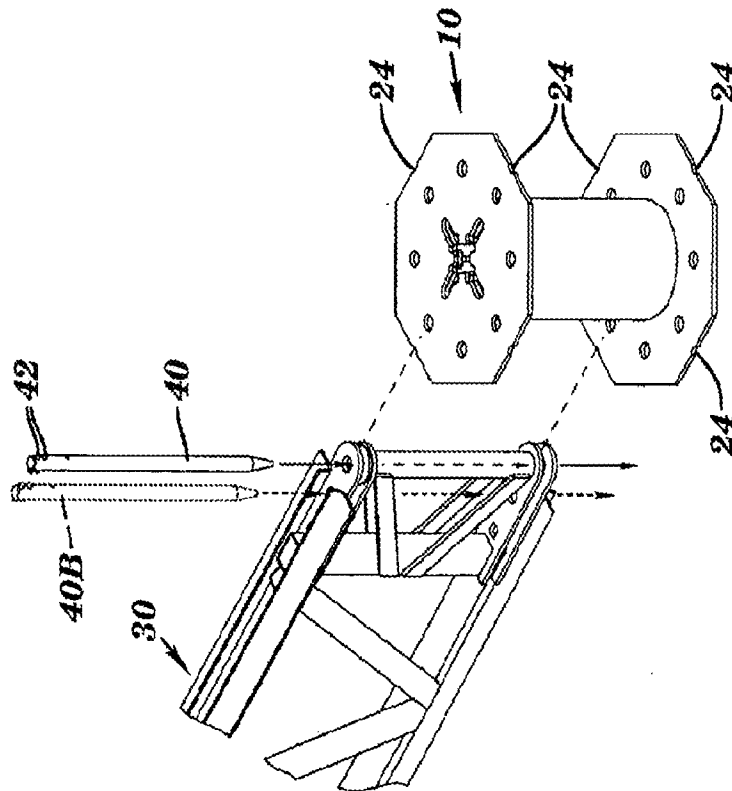
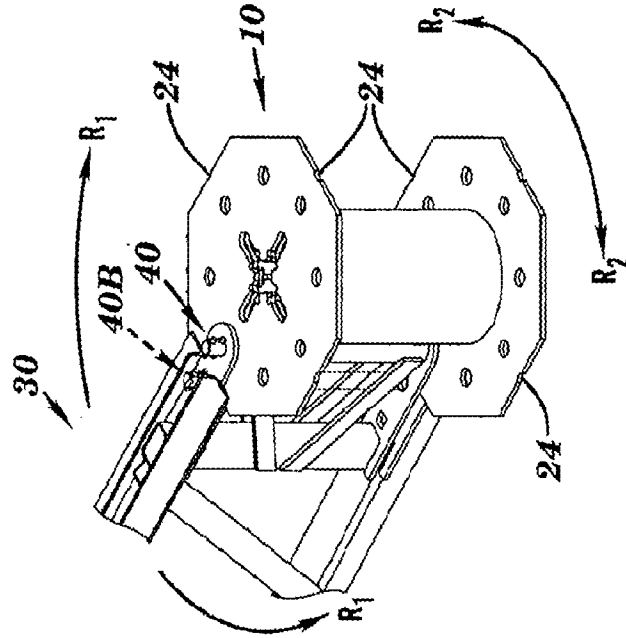
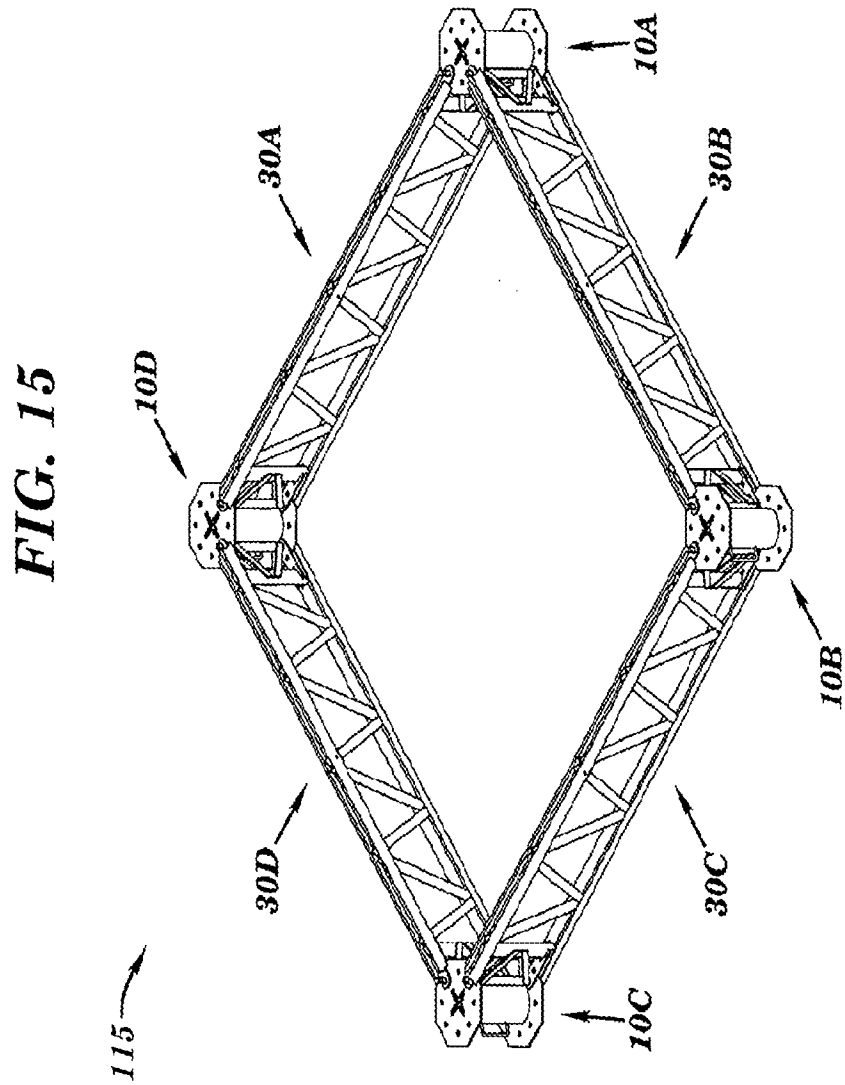
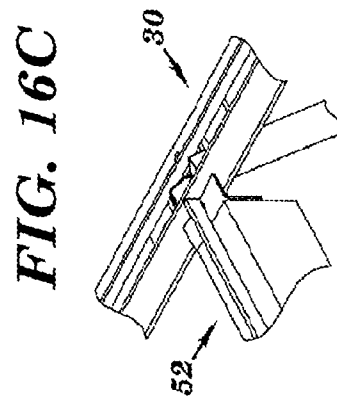
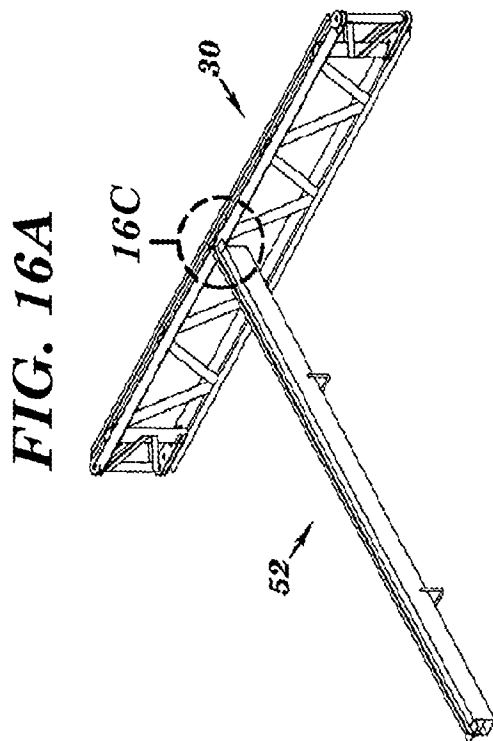
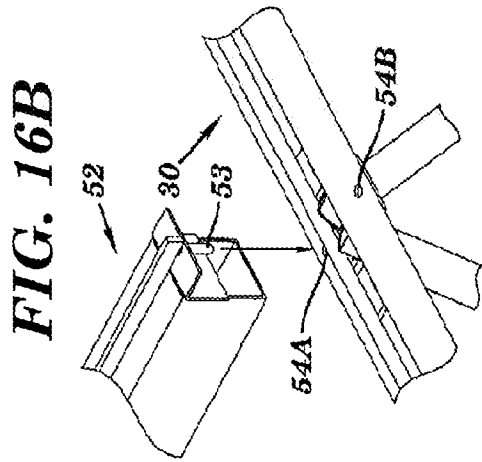
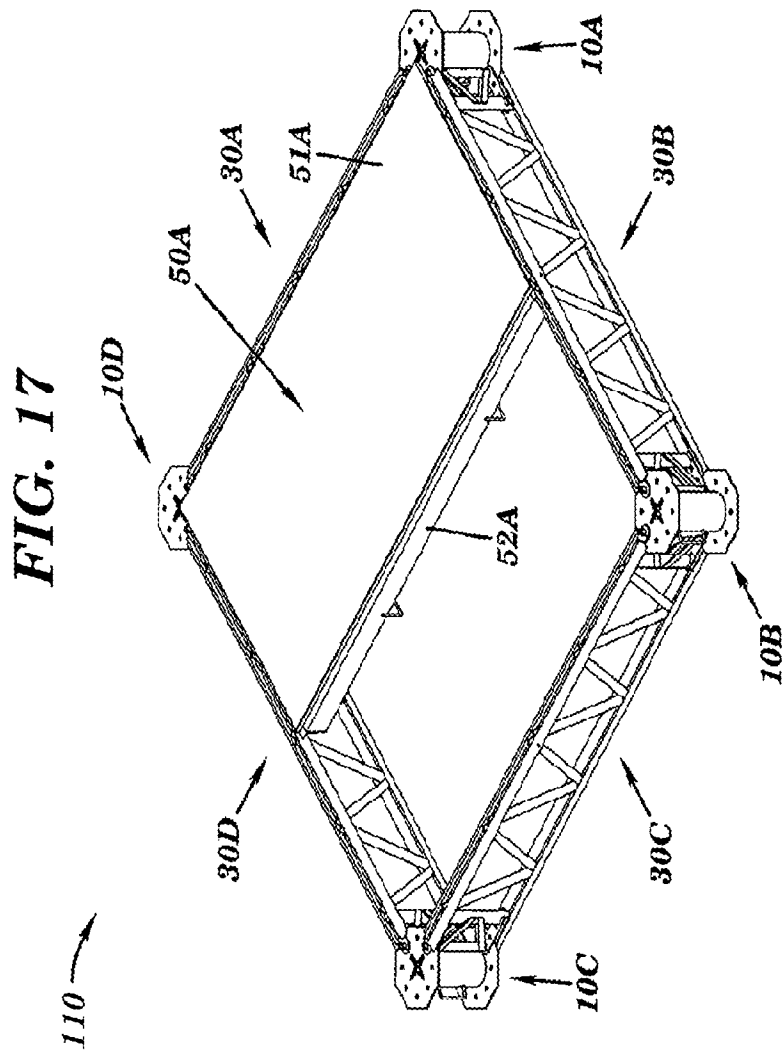


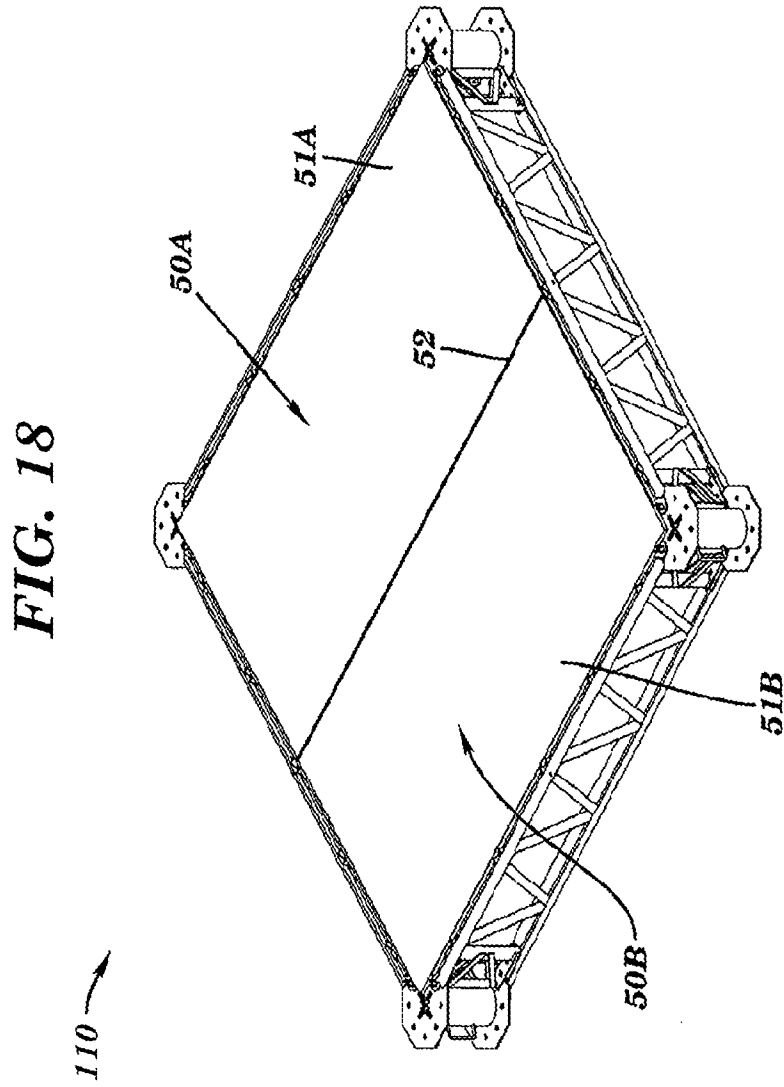
FIG. 14B



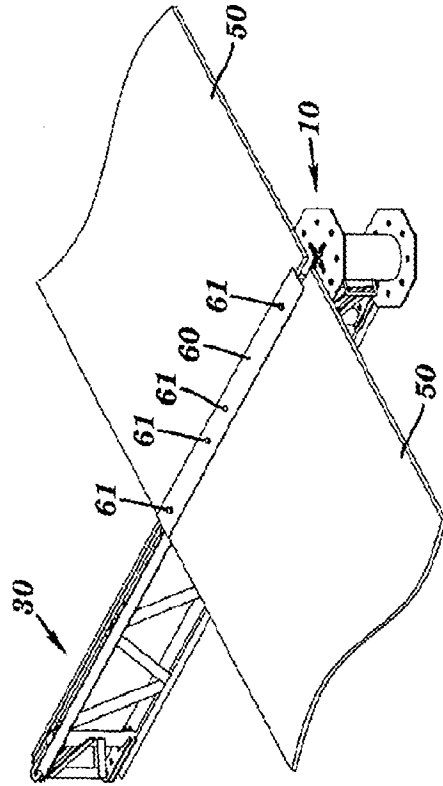




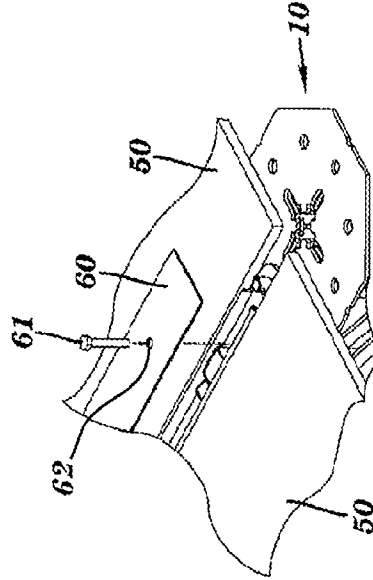




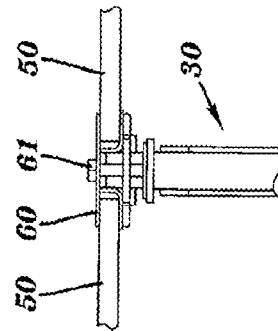
**FIG. 19A**



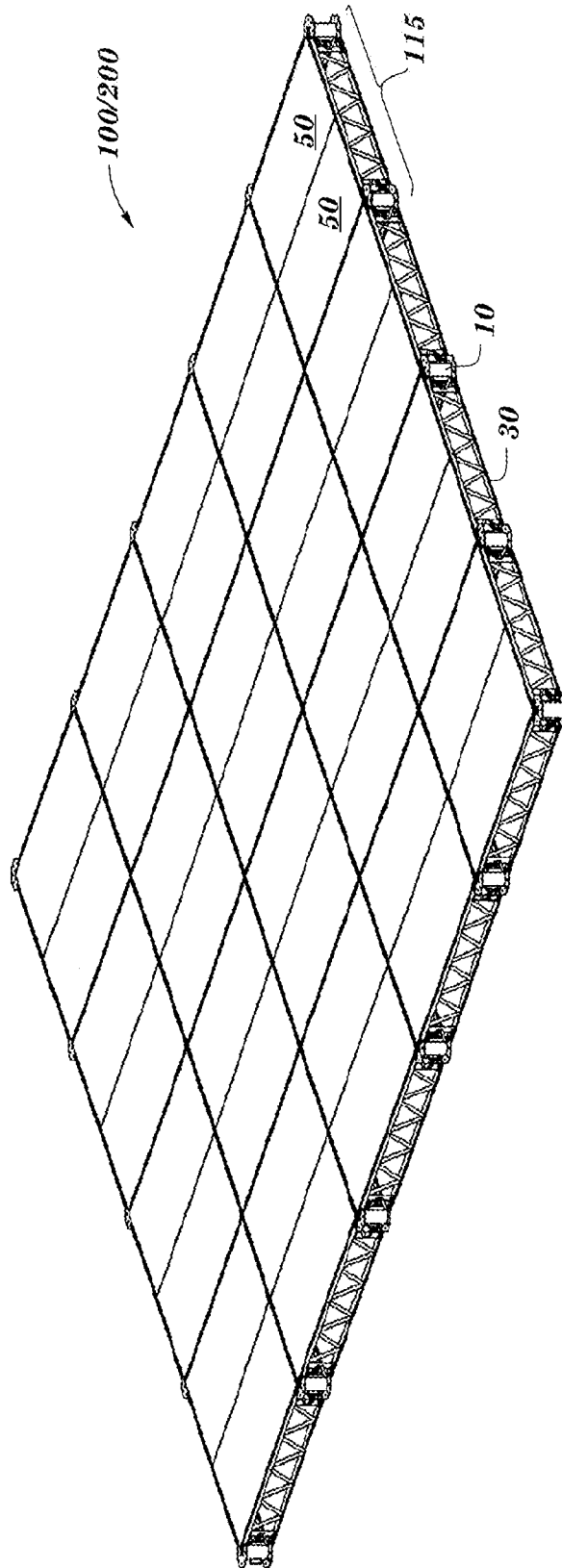
**FIG. 19B**



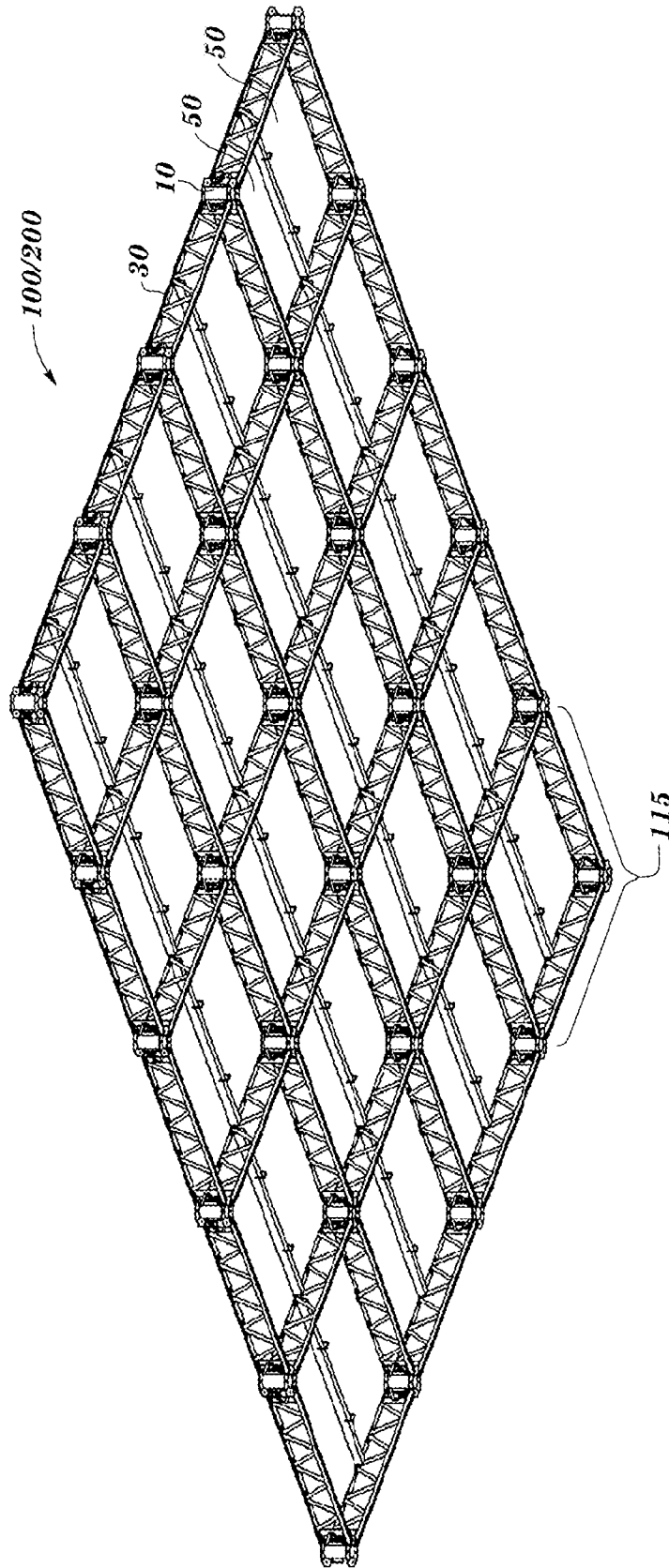
**FIG. 19C**



**FIG. 20**



**FIG. 21**



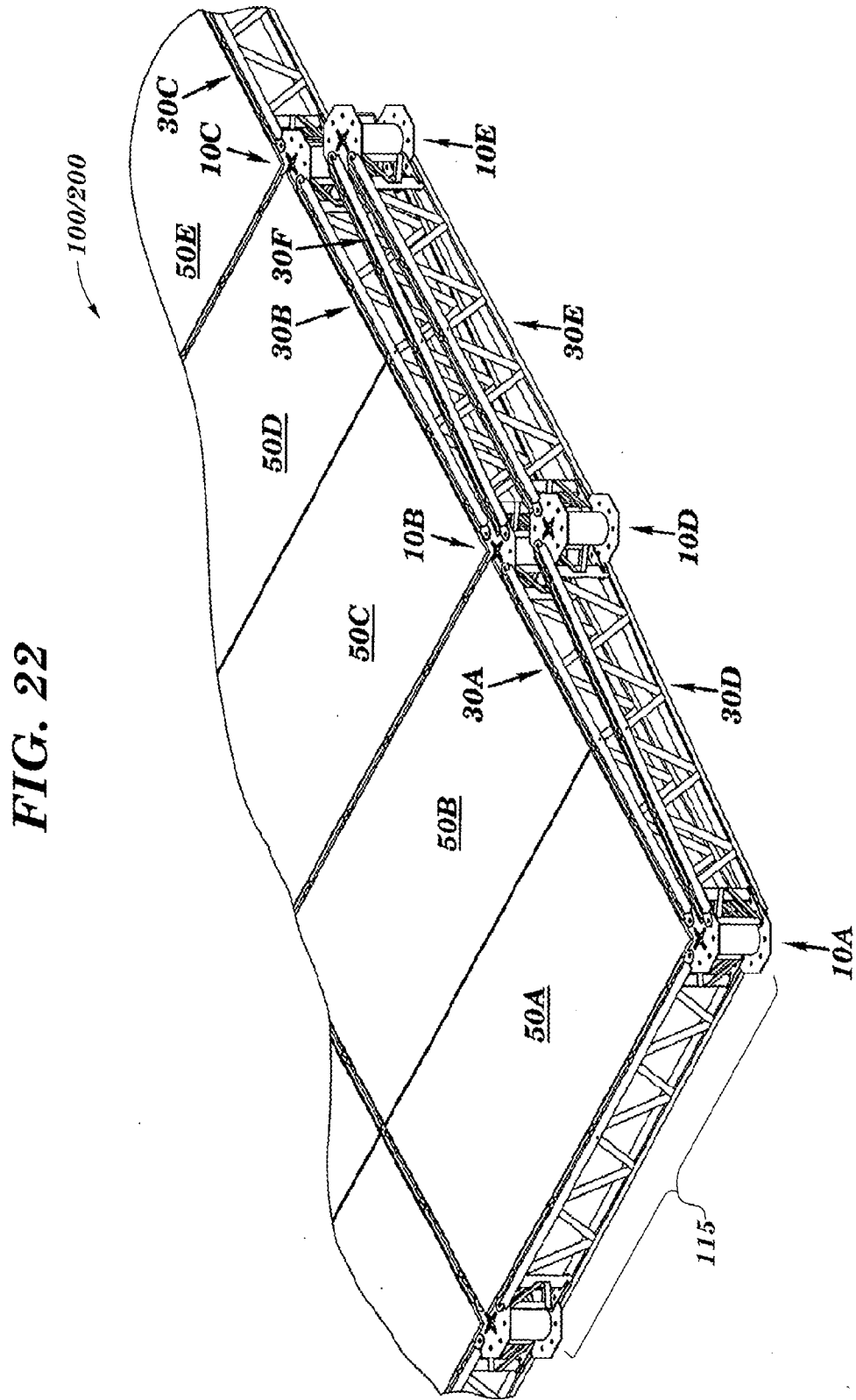


FIG. 22

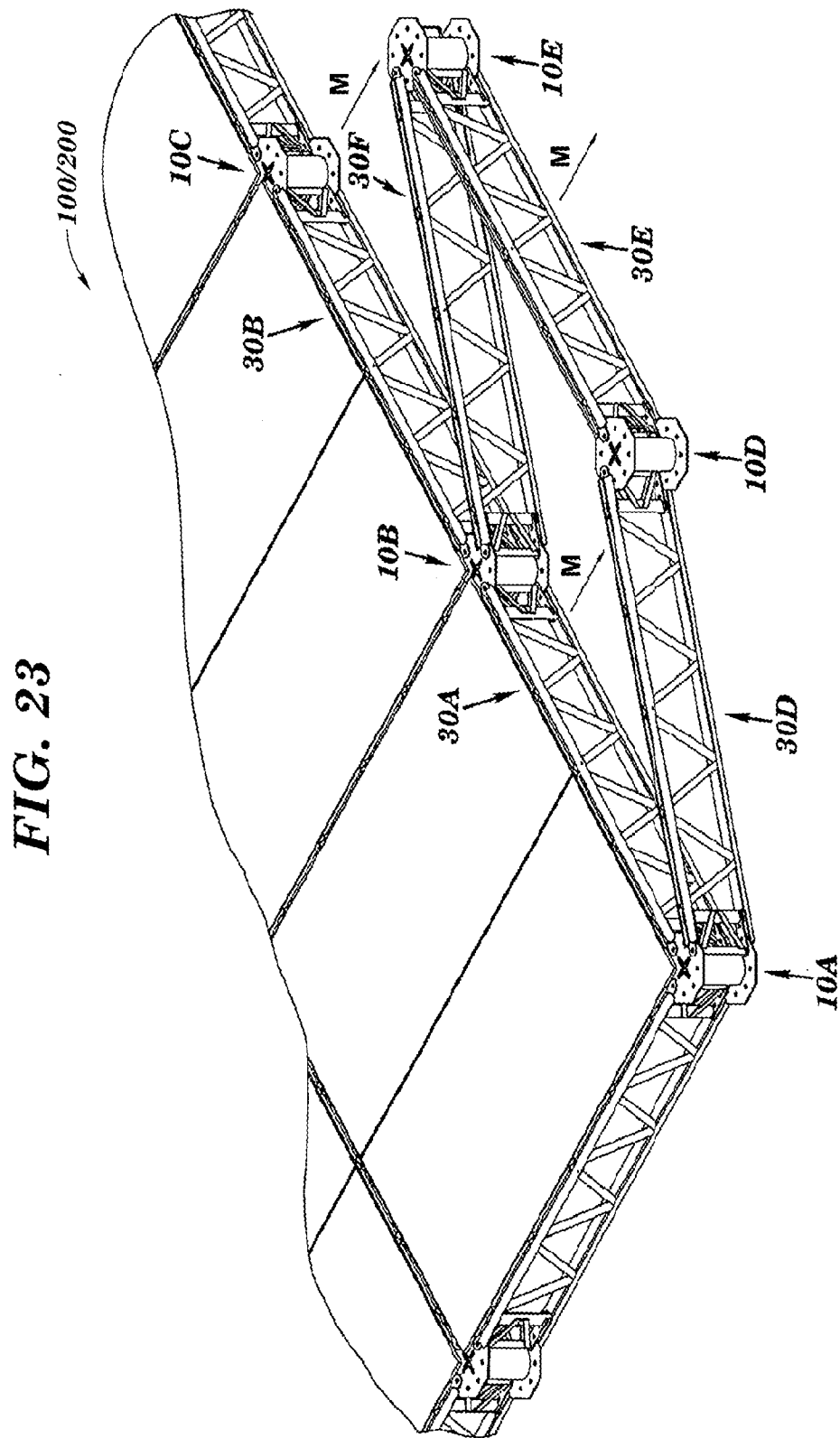


FIG. 23

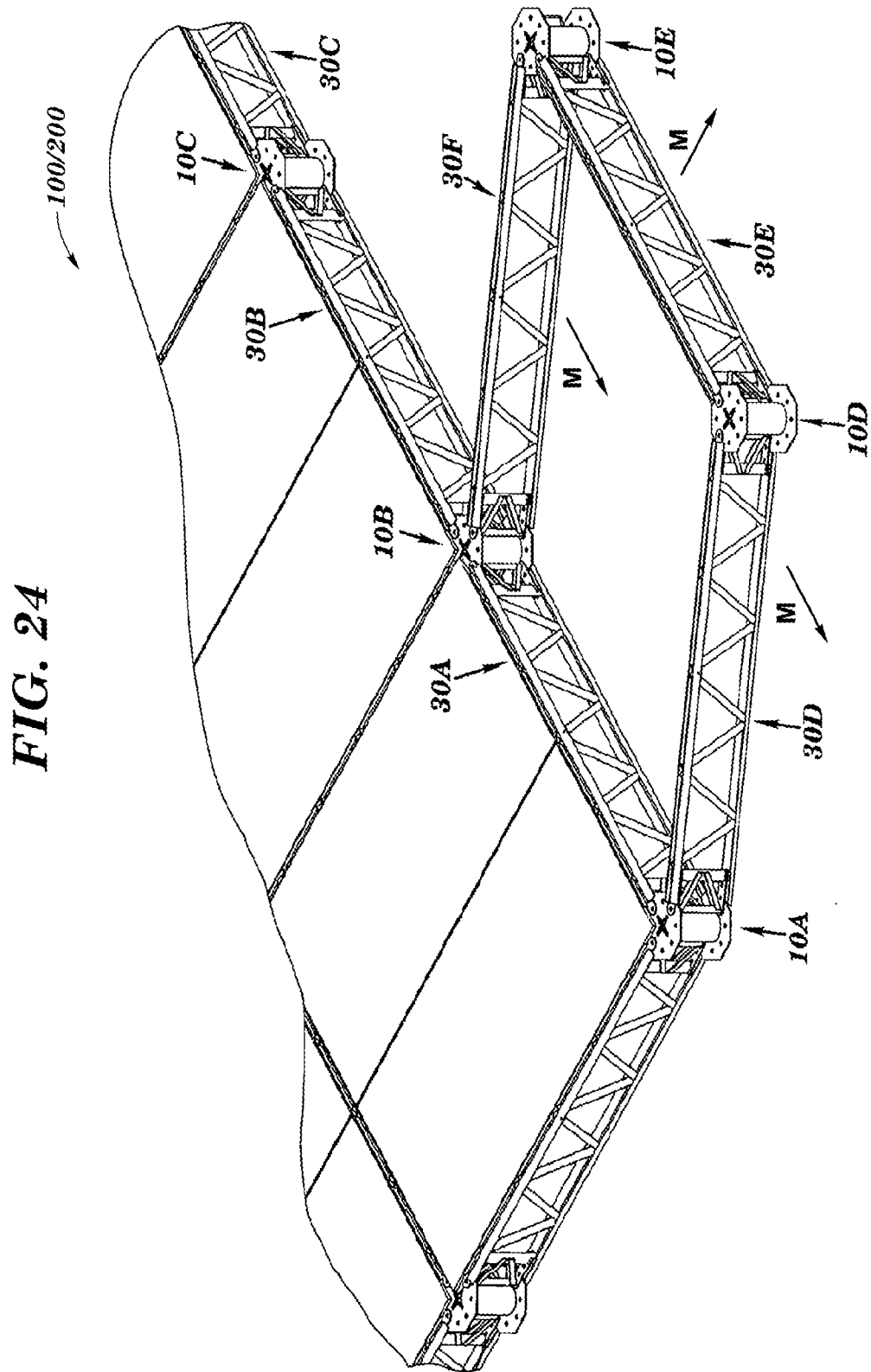
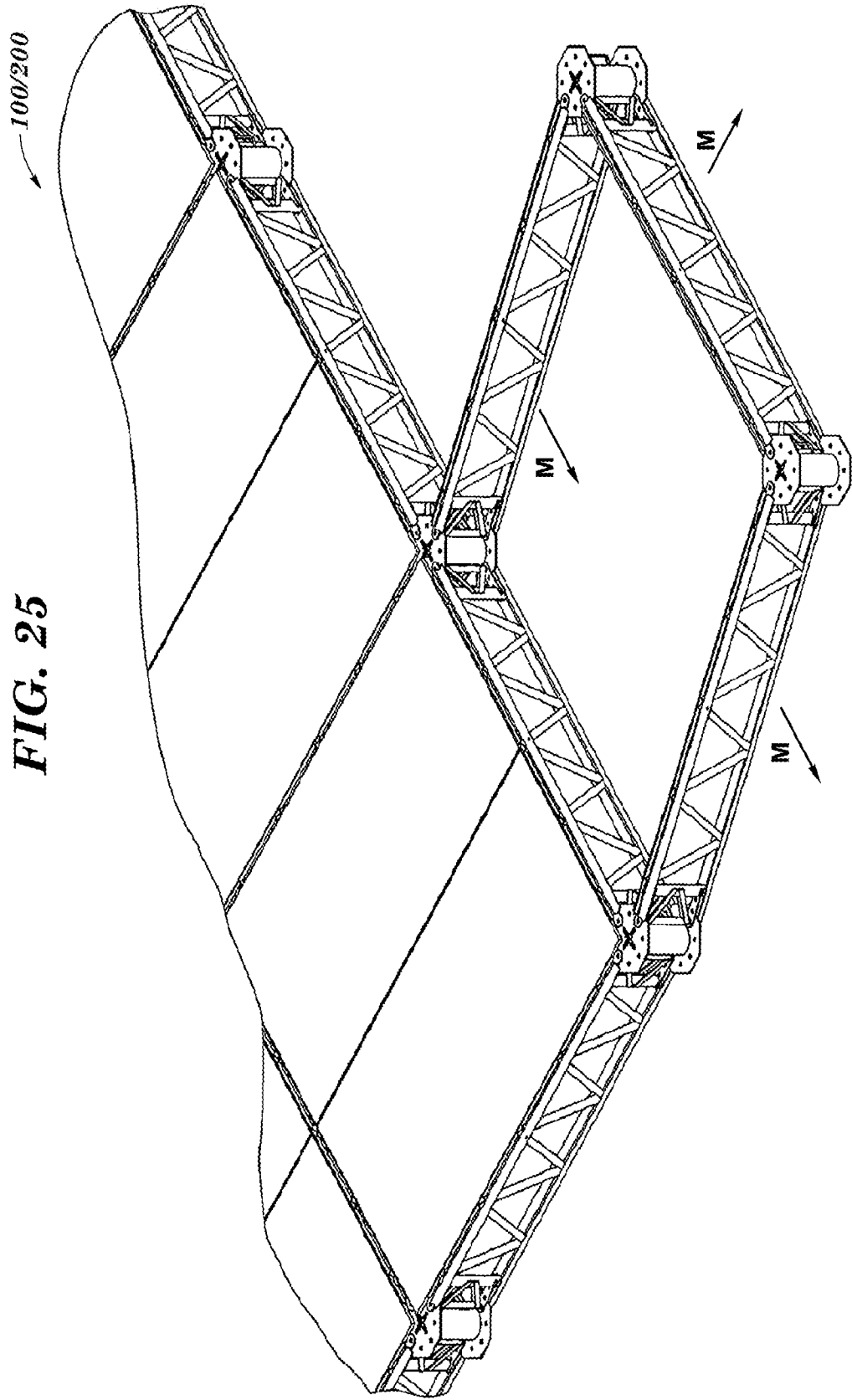
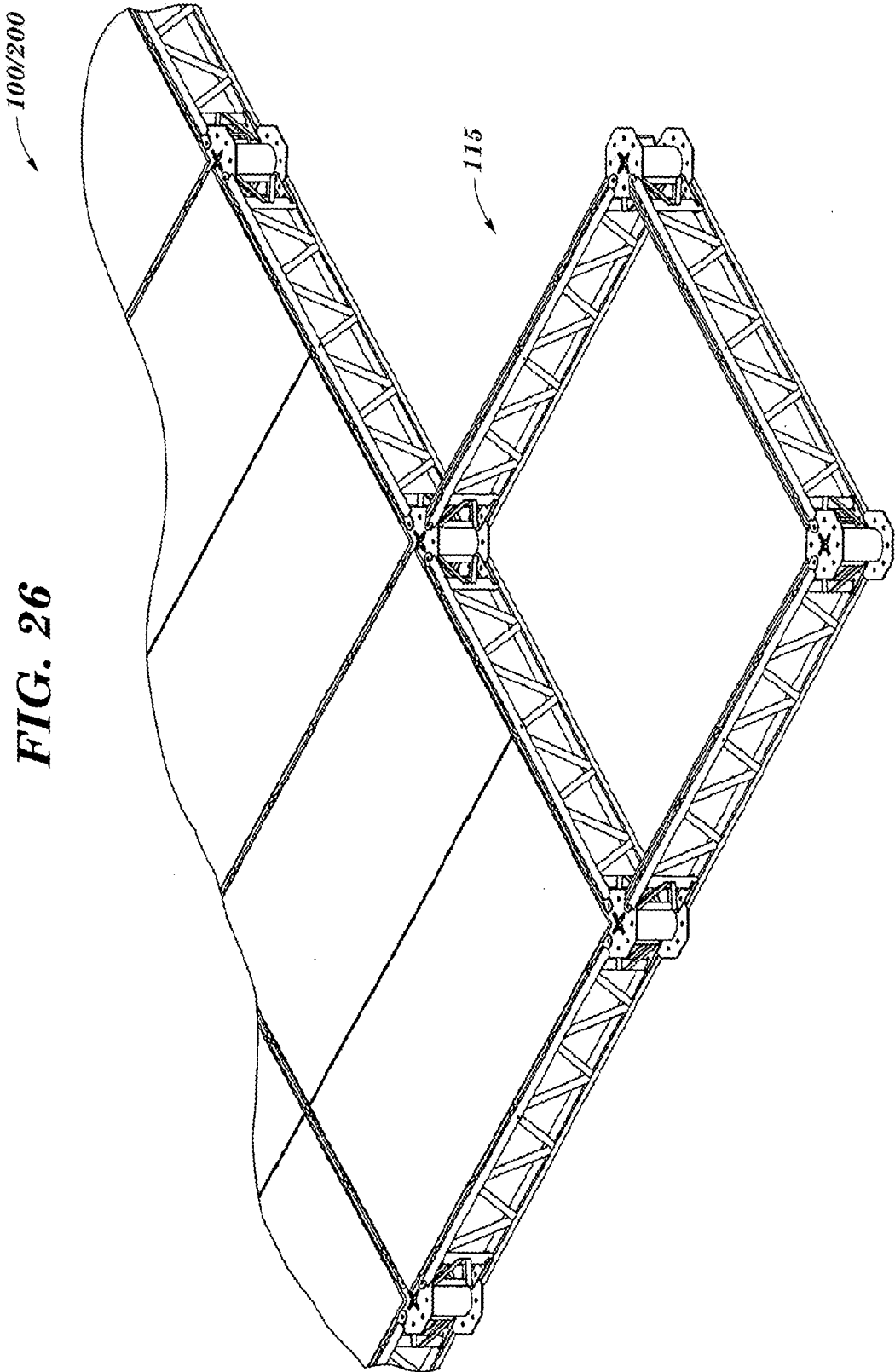


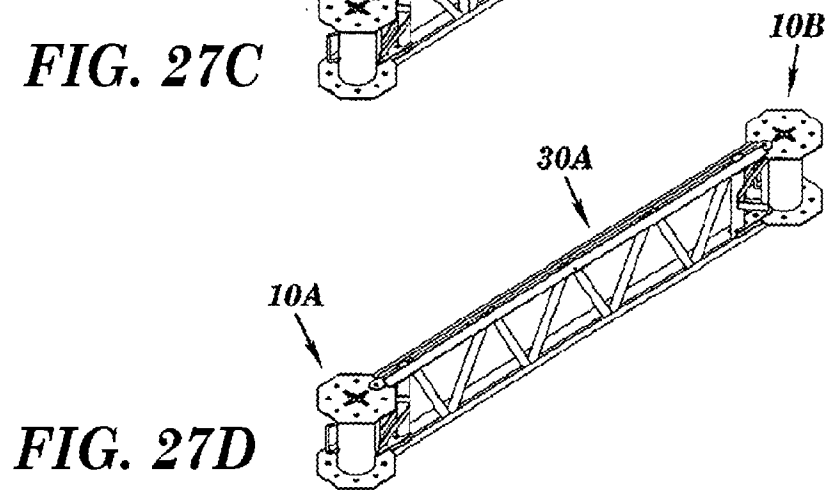
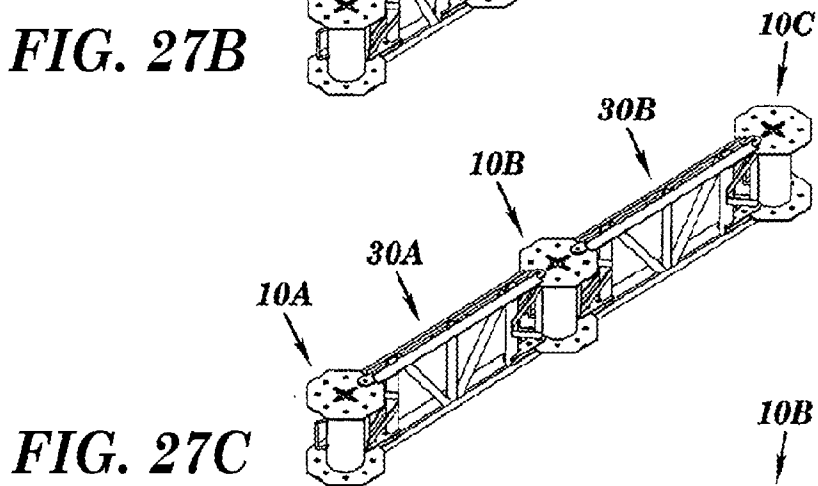
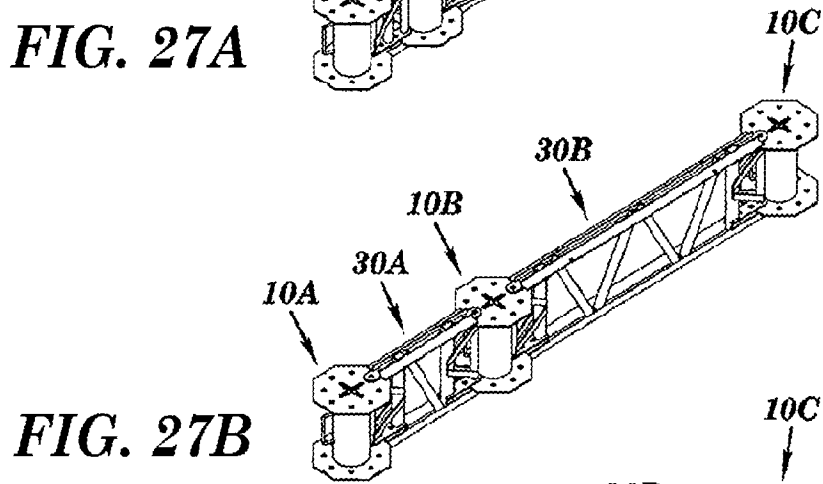
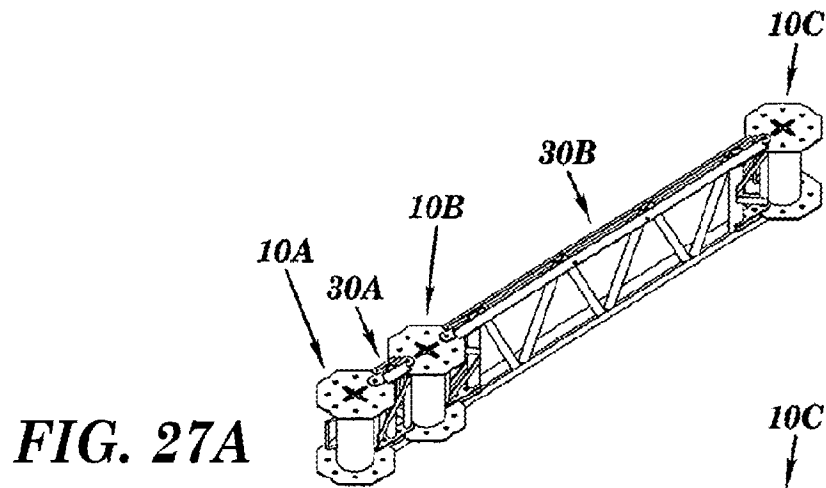
FIG. 24



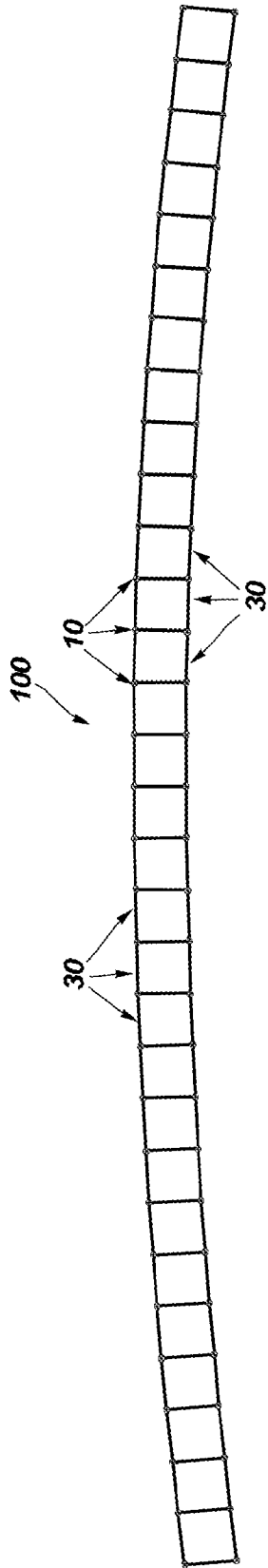
**FIG. 25**



**FIG. 26**



**FIG. 28A**



**FIG. 28B**

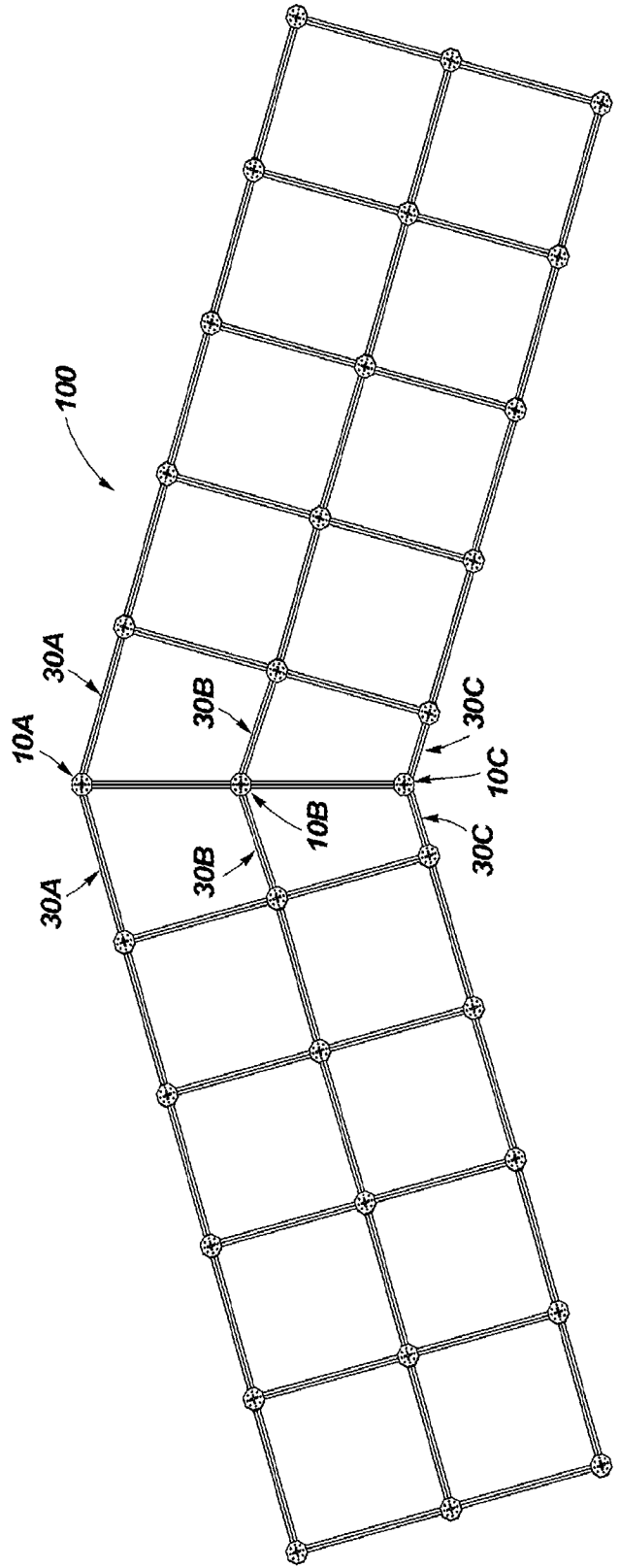
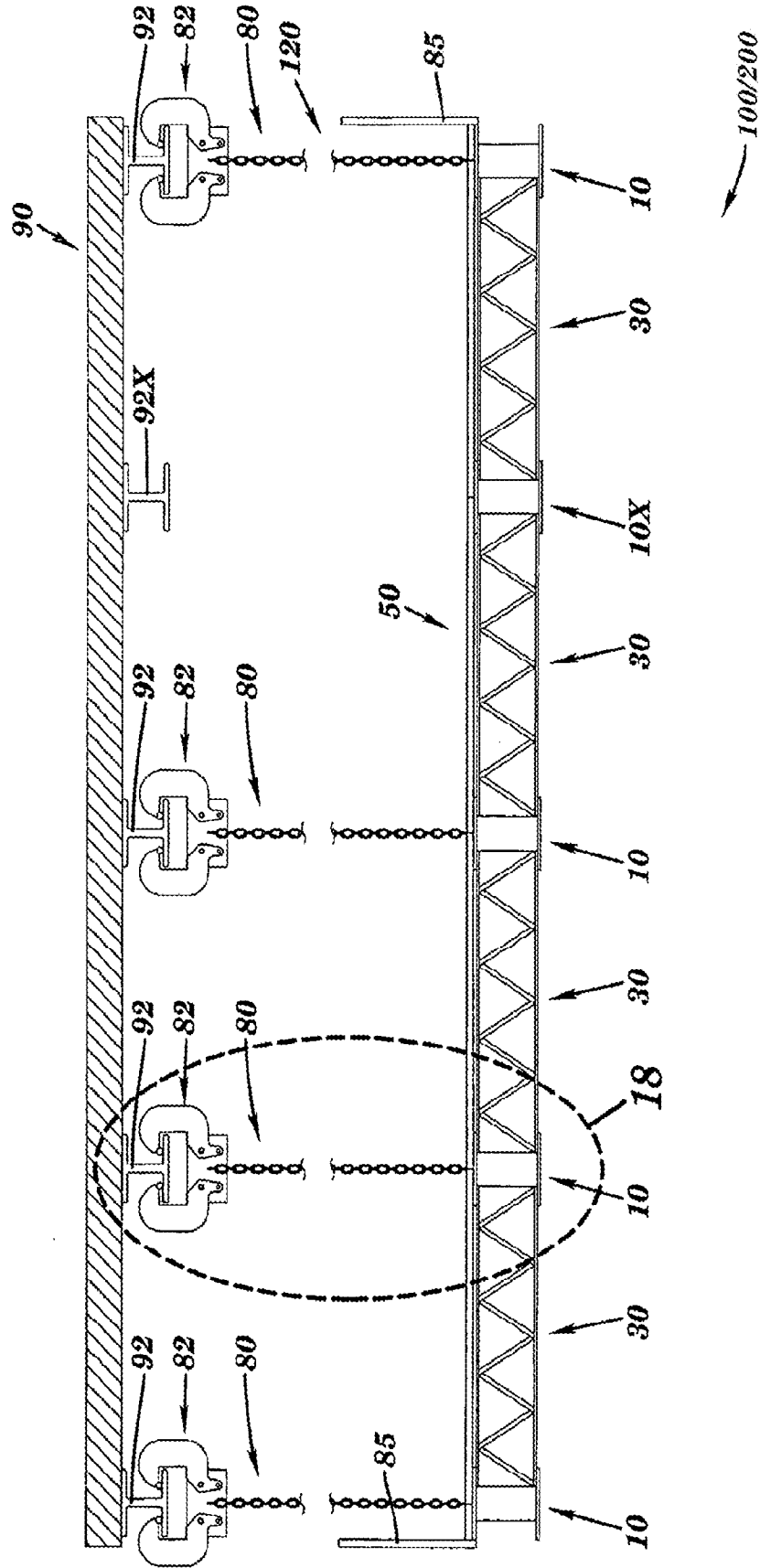
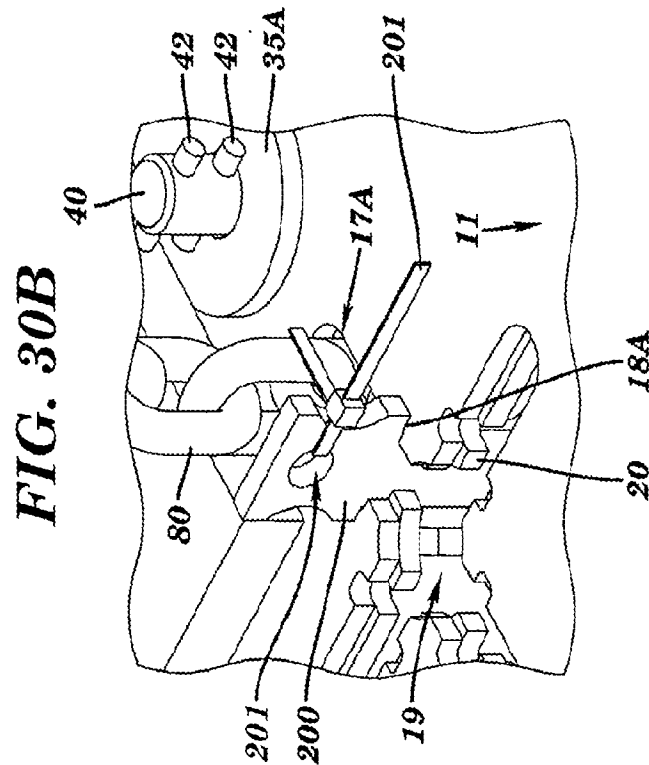
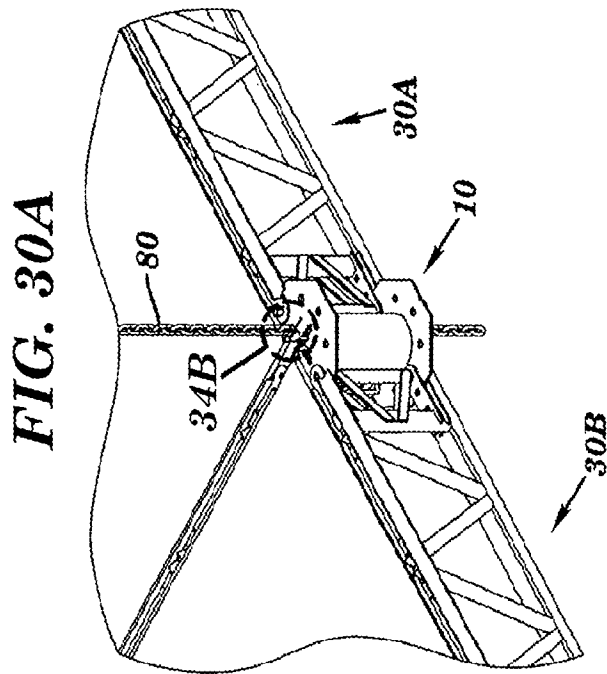


FIG. 29





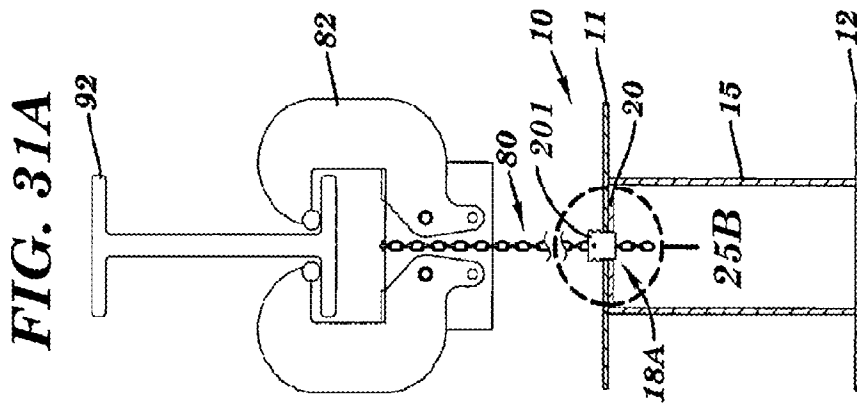
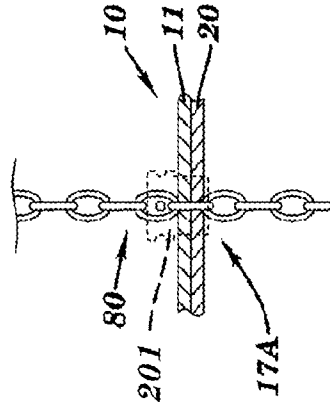
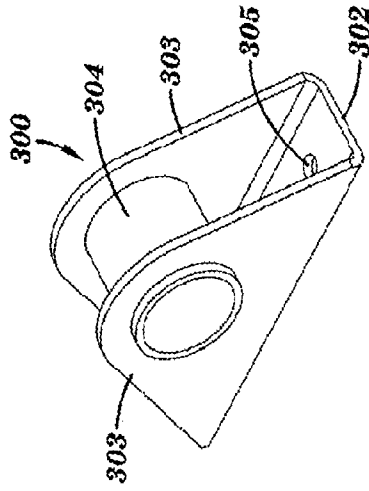


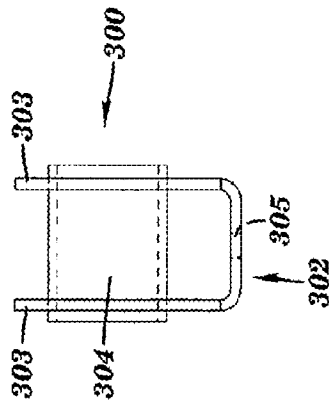
FIG. 31B



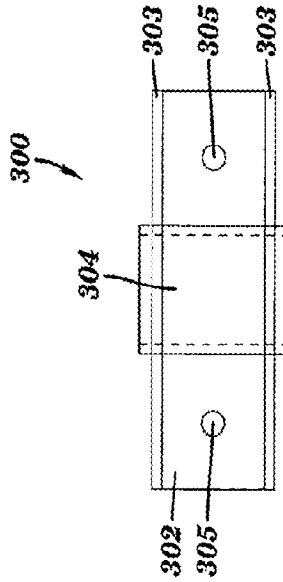
**FIG. 32A**



**FIG. 32C**



**FIG. 32B**



**FIG. 32D**

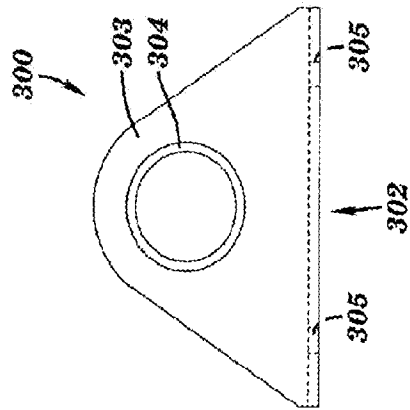
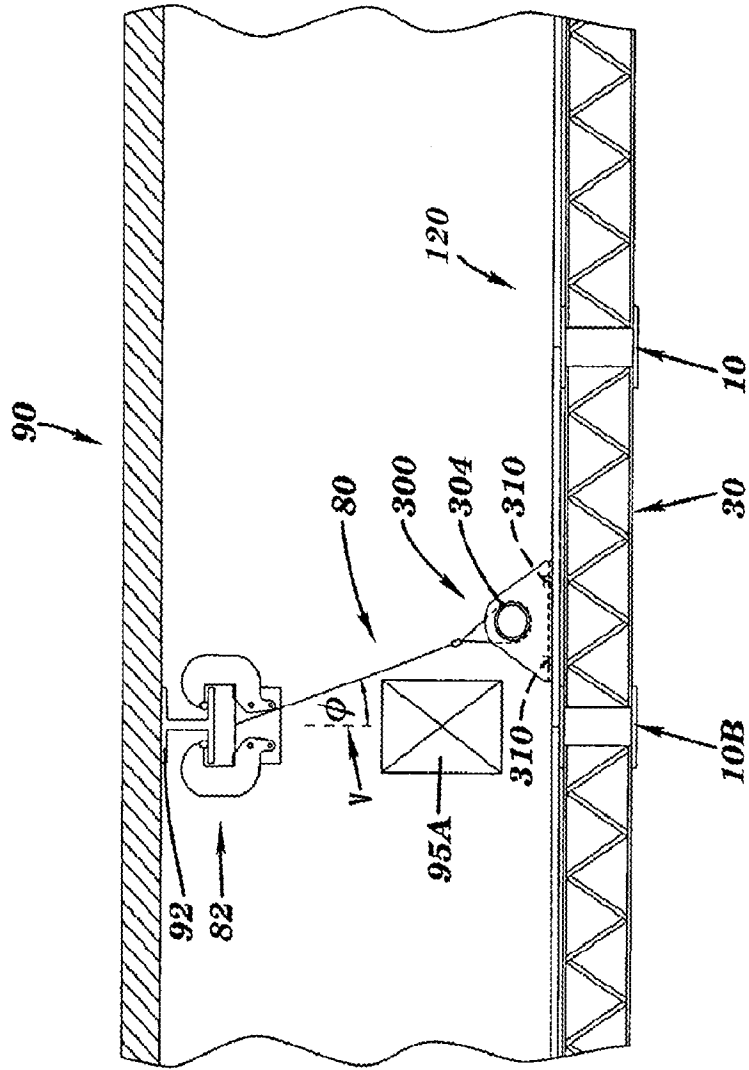


FIG. 33



**FIG. 34A**

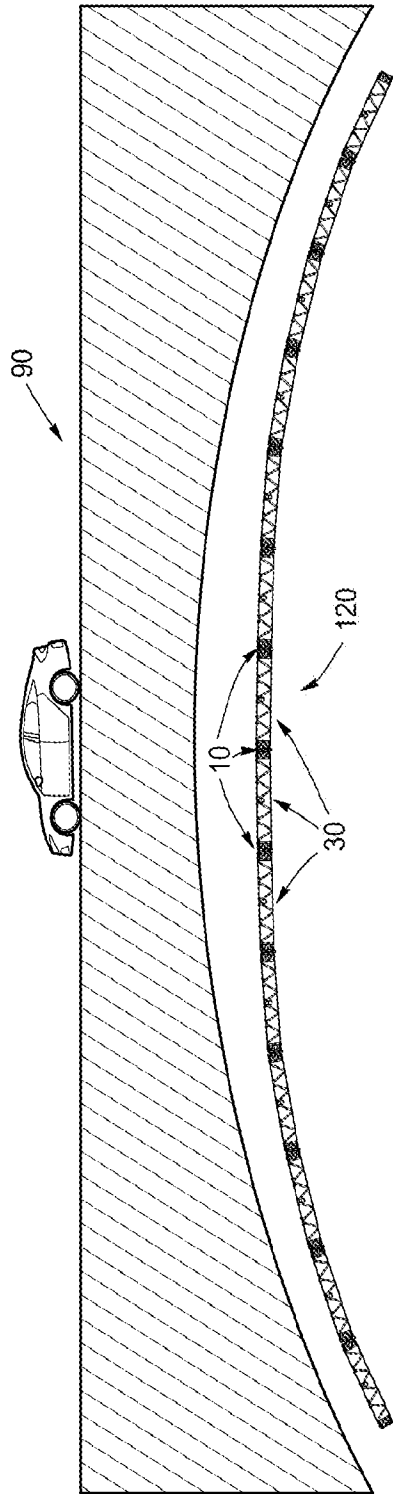


FIG. 34B

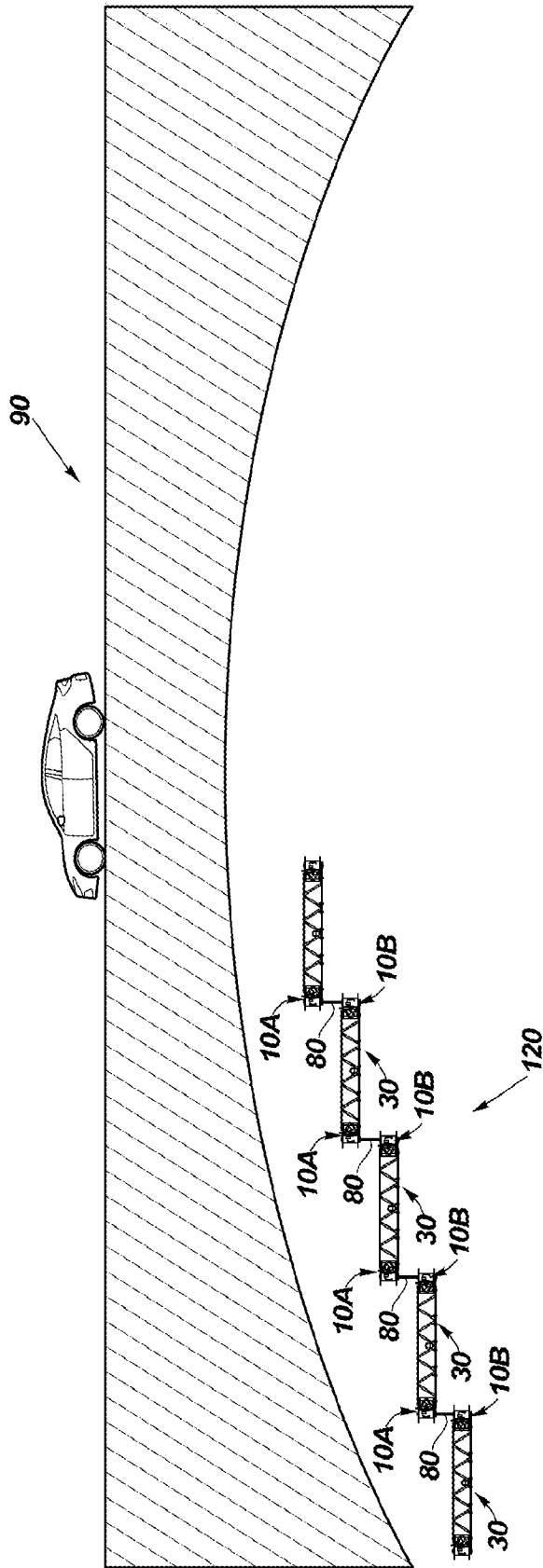
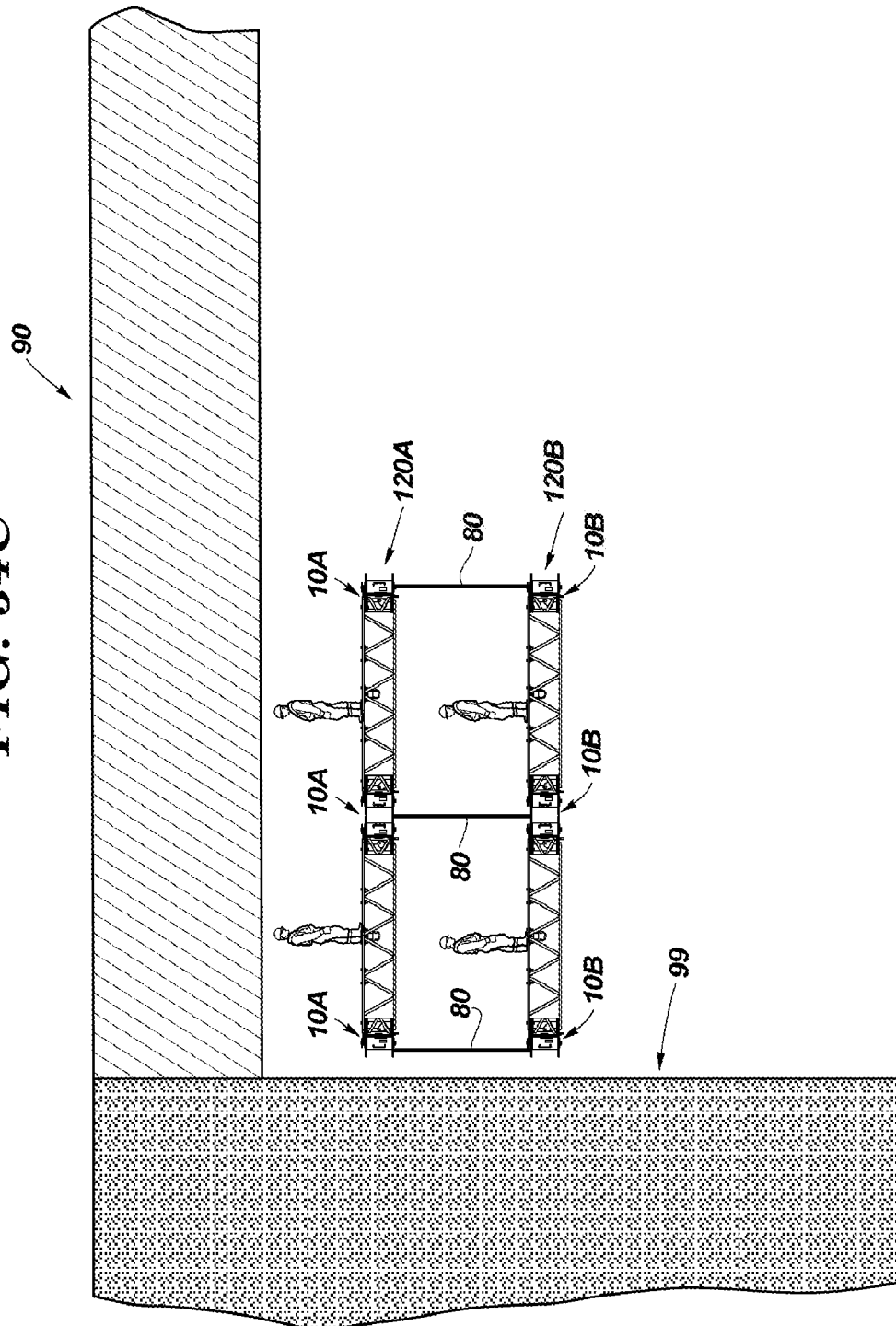
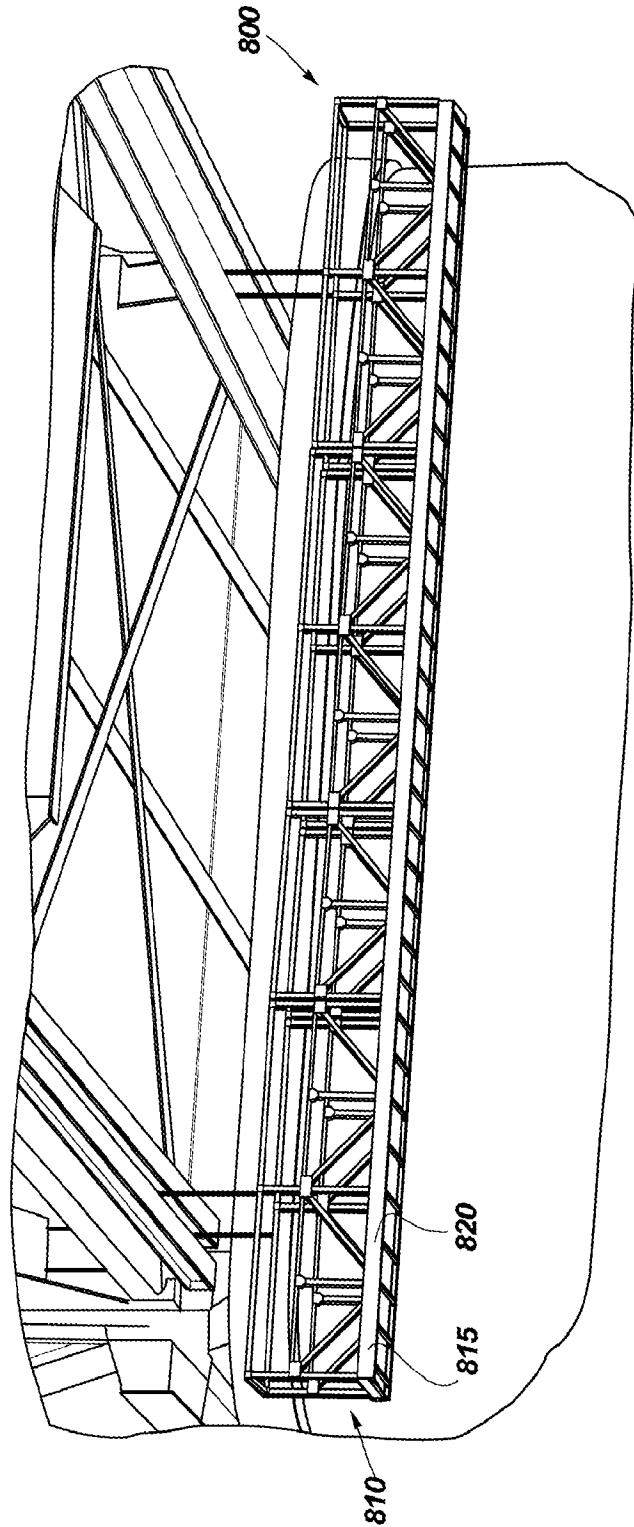


FIG. 34C



**FIG. 35**



**FIG. 36**

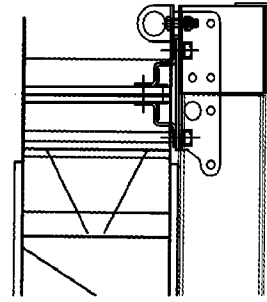


FIG. 37

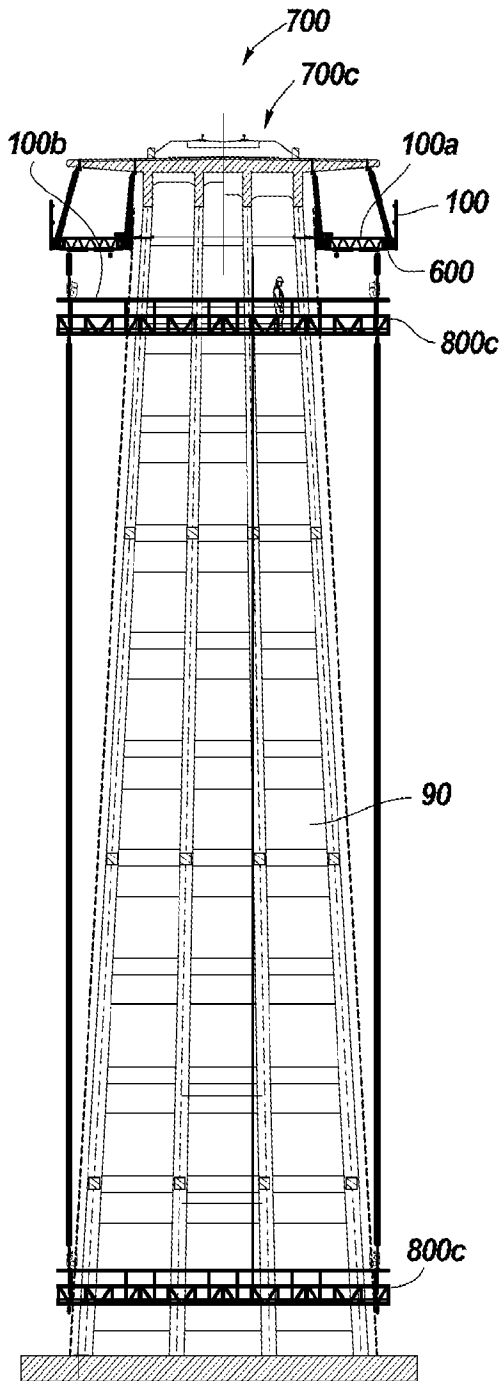
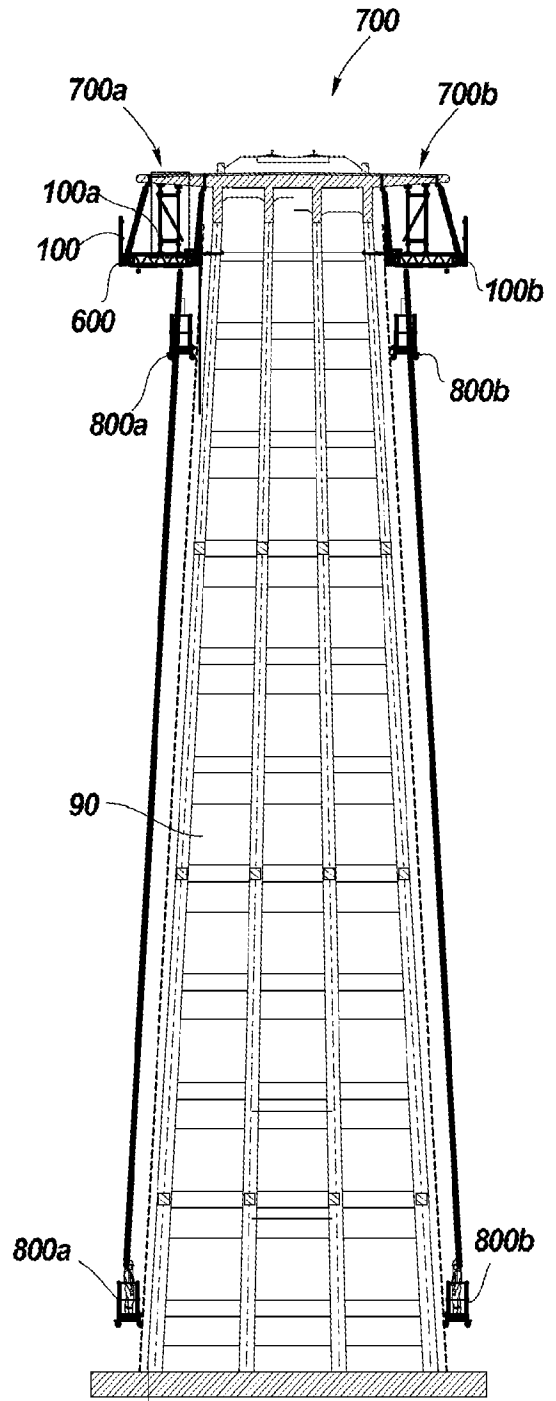
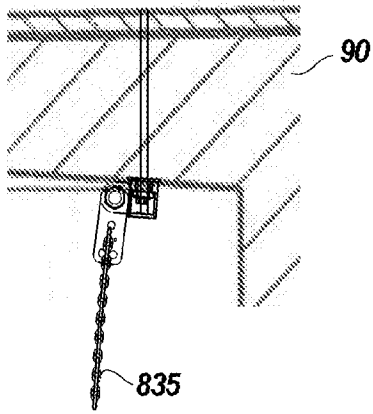


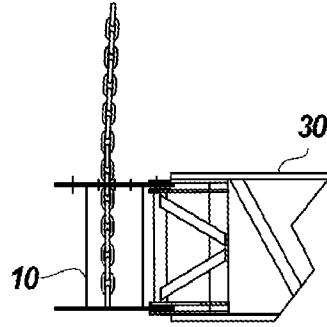
FIG. 38



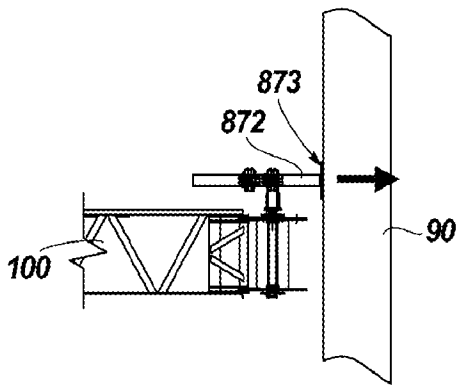
**FIG. 39**



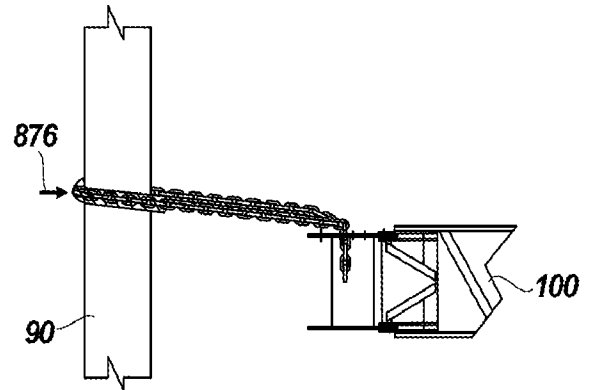
**FIG. 40**



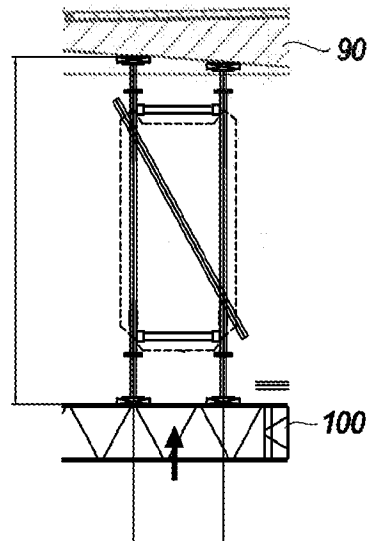
**FIG. 41**

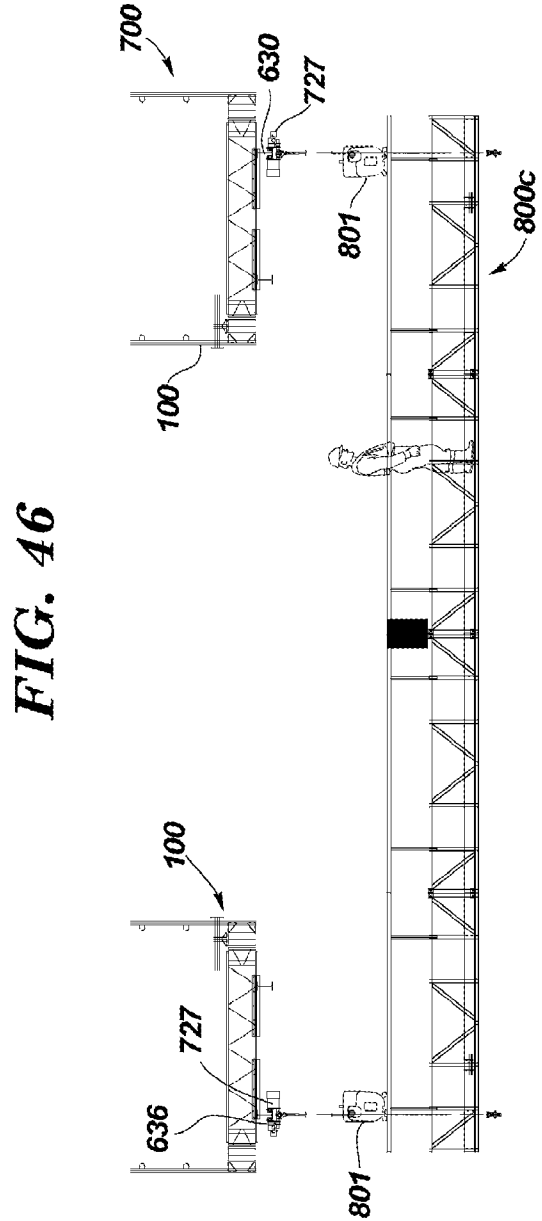
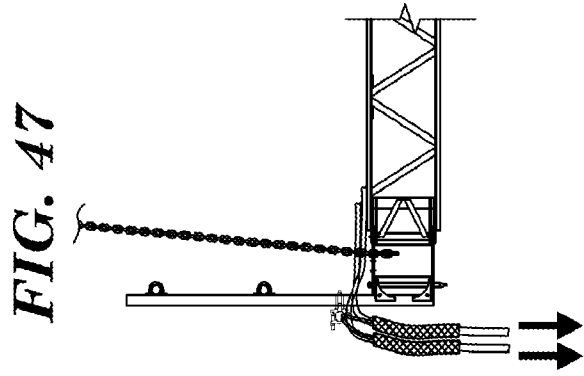
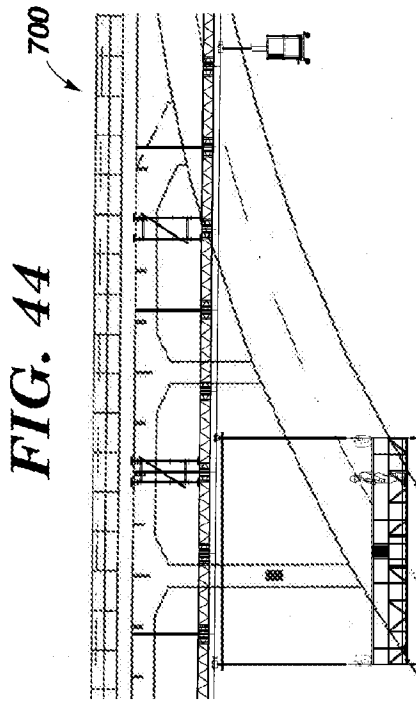
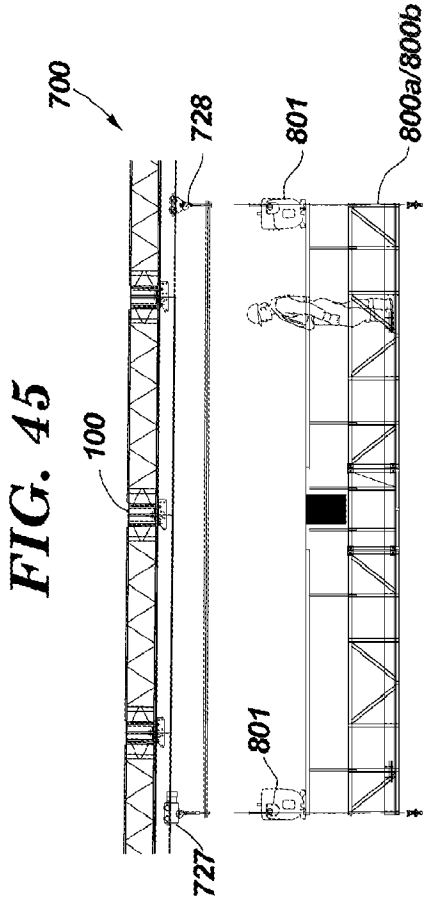


**FIG. 42**



**FIG. 43**





INTERNATIONAL SEARCH REPORT

International application No.

PCT/US2020/044566

A. CLASSIFICATION OF SUBJECT MATTER  
 IPC(8) - E04G 3/28; E04G 3/00; E04G 3/18 (2020.01)  
 CPC - E04G 3/28; E04G 3/00; E04G 3/18 (2020.08)

According to International Patent Classification (IPC) or to both national classification and IPC

B. FIELDS SEARCHED

Minimum documentation searched (classification system followed by classification symbols)  
 see Search History document

Documentation searched other than minimum documentation to the extent that such documents are included in the fields searched  
 see Search History document

Electronic data base consulted during the international search (name of data base and, where practicable, search terms used)  
 see Search History document

C. DOCUMENTS CONSIDERED TO BE RELEVANT

Category*	Citation of document, with indication, where appropriate, of the relevant passages	Relevant to claim No.
X	US 3,016,105 A (HOUSE) 09 January 1962 (09.01.1962) entire document	1-4
X	US 1,127,445 A (JOHNSTON) 09 February 1915 (09.02.1915) entire document	9-11
A	US 2015/0041252 A1 (SAFWAY SERVICES, LLC) 12 February 2015 (12.02.2015) entire document	1-4, 9-11
A	US 2006/0086568 A1 (VAILLANCOURT) 27 April 2006 (27.04.2006) entire document	1-4, 9-11

Further documents are listed in the continuation of Box C.  See patent family annex.

\* Special categories of cited documents:  
 "A" document defining the general state of the art which is not considered to be of particular relevance  
 "D" document cited by the applicant in the international application  
 "E" earlier application or patent but published on or after the international filing date  
 "L" document which may throw doubts on priority claim(s) or which is cited to establish the publication date of another citation or other special reason (as specified)  
 "O" document referring to an oral disclosure, use, exhibition or other means  
 "P" document published prior to the international filing date but later than the priority date claimed  
 "T" later document published after the international filing date or priority date and not in conflict with the application but cited to understand the principle or theory underlying the invention  
 "X" document of particular relevance; the claimed invention cannot be considered novel or cannot be considered to involve an inventive step when the document is taken alone  
 "Y" document of particular relevance; the claimed invention cannot be considered to involve an inventive step when the document is combined with one or more other such documents, such combination being obvious to a person skilled in the art  
 "&" document member of the same patent family

Date of the actual completion of the international search  
 25 September 2020

Date of mailing of the international search report  
**15 OCT 2020**

Name and mailing address of the ISA/US  
 Mail Stop PCT, Attn: ISA/US, Commissioner for Patents  
 P.O. Box 1450, Alexandria, VA 22313-1450  
 Facsimile No. 571-273-8300

Authorized officer  
 Blaine R. Copenheaver  
 Telephone No. PCT Helpdesk: 571-272-4300

INTERNATIONAL SEARCH REPORT

International application No.  
PCT/US2020/044566

**Box No. II Observations where certain claims were found unsearchable (Continuation of item 2 of first sheet)**

This international search report has not been established in respect of certain claims under Article 17(2)(a) for the following reasons:

1.  Claims Nos.:  
because they relate to subject matter not required to be searched by this Authority, namely:
  
2.  Claims Nos.:  
because they relate to parts of the international application that do not comply with the prescribed requirements to such an extent that no meaningful international search can be carried out, specifically:
  
3.  Claims Nos.: 5-8, 12-15  
because they are dependent claims and are not drafted in accordance with the second and third sentences of Rule 6.4(a).

**Box No. III Observations where unity of invention is lacking (Continuation of item 3 of first sheet)**

This International Searching Authority found multiple inventions in this international application, as follows:

1.  As all required additional search fees were timely paid by the applicant, this international search report covers all searchable claims.
2.  As all searchable claims could be searched without effort justifying additional fees, this Authority did not invite payment of additional fees.
3.  As only some of the required additional search fees were timely paid by the applicant, this international search report covers only those claims for which fees were paid, specifically claims Nos.:
  
4.  No required additional search fees were timely paid by the applicant. Consequently, this international search report is restricted to the invention first mentioned in the claims; it is covered by claims Nos.:

**Remark on Protest**

- The additional search fees were accompanied by the applicant's protest and, where applicable, the payment of a protest fee.
- The additional search fees were accompanied by the applicant's protest but the applicable protest fee was not paid within the time limit specified in the invitation.
- No protest accompanied the payment of additional search fees.