

(19) World Intellectual Property Organization
International Bureau



(43) International Publication Date
27 February 2003 (27.02.2003)

PCT

(10) International Publication Number
WO 03/016554 A1

- (51) International Patent Classification⁷: **C12Q 1/00**
- (21) International Application Number: PCT/GB02/03818
- (22) International Filing Date: 16 August 2002 (16.08.2002)
- (25) Filing Language: English
- (26) Publication Language: English
- (30) Priority Data:
0120062.5 17 August 2001 (17.08.2001) GB
60/335,185 15 November 2001 (15.11.2001) US
- (71) Applicant (for all designated States except US): **OSME-TECH PLC** [GB/GB]; Electra House, Electra Way, Crewe, Cheshire CW1 1WZ (GB).
- (72) Inventors; and
- (75) Inventors/Applicants (for US only): **TRAVERS, Paul, James** [GB/GB]; 111 Longford Road, Chorlton, Manchester, Lancashire M21 9WW (GB). **CHAUDRY, Amjad, Nissar** [GB/GB]; Flat 2, 24 Stockton Road, Chorlton, Manchester, Lancashire M21 9ED (GB). **TUMMON, Andrew, John** [GB/GB]; 20 Beech Street, Middlewich, Cheshire CW10 9BT (GB). **HENERY, Martin, James** [GB/GB]; Holly Trees, 18 The Circuit, Alderley Edge, Cheshire SK9 7LT (GB).
- (74) Agents: **COLLINGWOOD, Anthony, Robert** et al.; Mc-Neight & Lawrence, Regent House, Heaton Lane, Stockport, Cheshire SK4 1BS (GB).
- (81) Designated States (national): AE, AG, AL, AM, AT, AU, AZ, BA, BB, BG, BR, BY, BZ, CA, CH, CN, CO, CR, CU, CZ, DE, DK, DM, DZ, EC, EE, ES, FI, GB, GD, GE, GH, GM, HR, HU, ID, IL, IN, IS, JP, KE, KG, KP, KR, KZ, LC, LK, LR, LS, LT, LU, LV, MA, MD, MG, MK, MN, MW, MX, MZ, NO, NZ, OM, PH, PL, PT, RO, RU, SD, SE, SG, SI, SK, SL, TJ, TM, TN, TR, TT, TZ, UA, UG, US, UZ, VC, VN, YU, ZA, ZM, ZW.
- (84) Designated States (regional): ARIPO patent (GH, GM, KE, LS, MW, MZ, SD, SL, SZ, TZ, UG, ZM, ZW), Eurasian patent (AM, AZ, BY, KG, KZ, MD, RU, TJ, TM), European patent (AT, BE, BG, CH, CY, CZ, DE, DK, EE, ES, FI, FR, GB, GR, IE, IT, LU, MC, NL, PT, SE, SK, TR), OAPI patent (BF, BJ, CF, CG, CI, CM, GA, GN, GQ, GW, ML, MR, NE, SN, TD, TG).

Published:

— with international search report

For two-letter codes and other abbreviations, refer to the "Guidance Notes on Codes and Abbreviations" appearing at the beginning of each regular issue of the PCT Gazette.



WO 03/016554 A1

(54) Title: DETECTION OF BACTERIAL VAGINOSIS

(57) Abstract: There is disclosed a method for detecting the presence of bacterial vaginosis in a female subject comprising the steps of: obtaining a sample from the vaginal region of the subject; detecting acetic acid present in the sample; and correlating the presence of detected acetic acid with the presence of bacterial vaginosis.

DETECTION OF BACTERIAL VAGINOSIS

This invention relates to the detection of bacterial vaginosis using a gas detector.

Bacterial vaginosis (BV) is a well known, but not well understood or well defined, condition which exhibits uncertain symptoms. Numerous reports cite as much as 50% of the affected population being asymptomatic. The remaining 50% of the population either go undetected or present during routine examination for an associated or uncorrelated problem.

Originally thought to be a benign infection recent studies have linked the problem to increased risk of intra-amniotic infection, choroamnionitis, post-caesarean and post-partum endometritis, adverse pregnancy outcome, pre-term labour and birth, premature rupture of membranes at term and post-hysterectomy cuff cellulitis.

BV is commonly thought to arise as a result of fluctuation of the normal vaginal flora. In some cases the flora can fluctuate naturally over the menstrual cycle with no adverse effects. It is thought that one of the primary controlling mechanisms controlling BV causative bacteria is the presence of adequate colonies of *Lactobacillus* sp. that produce hydrogen peroxide. The most common organisms associated with BV are: *Gardnerella vaginalis*, *Bacteroides (Prevotella) spp.*, *Mobiluncus spp.* and *Mycoplasma hominis*. However, the presence or absence of these flora is not reliably diagnostic.

Treatment after a correct diagnosis is usually quite effective and usually comprises of treatment with oral doses of metronidazole. Topical treatments with metronidazole or clindamycin are also common. However, in Doctors' surgeries it is not

- 2 -

uncommon for general practitioners (GPs) to wrongly diagnose vaginal infections, e.g., some cases of Candida are diagnosed as BV and vice versa. A distinction between a yeast and bacterial infection is important, as non-specific antibiotics can cause more problems for the sufferer. For symptomatic patients, BV has an incidence of 40% compared with Candida and Trichomonas. A swift, preferably in-situ, diagnosis would enable immediate correct therapy (usually comprising antibiotics in the case of BV) to be administered. In GPs' surgeries, a means of differentiating a bacterial infection from a yeast infection would enable the correct type of treatment to be prescribed.

In fact, the consequences of BV are wide and varied and are not completely understood. This is perhaps unsurprising given the difficulties in getting reliable BV data for a population. The primary challenge facing any prospective diagnostic technique (or aid to diagnosis) is finding a unique indicator against which BV may be detected. Currently the Amsel test is the benchmark for determining the problem. The criteria for the test rely on at least three out of four conditions being met. These are;

- pH of vaginal fluid > 4.5
- Typical thin, homogenous vaginal discharge
- Release of strong fishy smell on adding alkali (10% KOH) to a sample of vaginal fluid (whiff test),
- Clue cells present on microscopic examination of a wet mount of vaginal fluid.

It should be noted that the presence of trimethylamine (TMA) in some BV samples is undisputed, and TMA is often cited as being the volatile associated with the unpleasant fishy odour referred to above.

Individually none of these tests are diagnostic. pH variation of the vaginal fluid is nearly always present in BV positive patients but it is a non-specific test and the

- 3 -

variation is equally likely to be caused by another infection or problem. Additionally, contamination of the sample by cervical mucus (typical pH 7) can lead to false diagnoses in some cases. pH variation also occurs as part of the natural menstrual cycle. Ethnic background is also a factor affecting vaginal pH and this has been postulated as a reason for the relatively higher number of black American women who present with the disease. According to Hay, pH is highly sensitive (97%) but very non-specific giving false positives in 47% of cases. Conversely, discharge is very accurately recognised by clinicians giving false positives at 3% but only has a specificity of 67%. Following this, the “whiff” test also gives low false positives (1%) but is non-specific (43%). Finally clue cells are typically found in 81% of positive BV cases whilst 6% of non-BV cases have positive clue cell tests. Other trials report variation on these figures but all concur with the non-specificity and reliability of any one individual test.

It is known from the applicant's International Application No. WO 95/33848 that microorganisms can be detected using arrays of gas sensors to detect characteristic gases or vapours produced by the microorganisms. An example of such an array is an array of semiconducting organic polymer gas sensors. The applicant's International Applications Nos. WO 98/29563 and WO 98/39470 describe further aspects and refinements to the technique, and related developments. In general, the approach with arrays of gas sensors is to utilise a large number (twenty, thirty or more) of different gas sensors which possesses different but overlapping sensitivities towards different gaseous species (so-called “electronic noses”). Gases are recognised from the characteristic “fingerprint” or pattern of response across the array. However, detection can be difficult in a complex system having mixed populations of microflora and microfaunae and/or systems in which many volatile species are present.

Of the particular relevance to the present application are International Application number WO 94/04916 and Chandiok et al (S. Chandiok, BA Crawley, BA Oppenheim, PR Chadwick, S Higgins, and K C Persaud, Journal of Clinical Pathology,

- 4 -

50 (1997) 790). Both documents describe attempts to detect BV using arrays of semiconducting organic polymers, and in both cases it is believed that the gaseous species detected were ammonia and/or TMA. In fact, WO 94/04916 specifically describes a process rather similar to the whiff test discussed above, in which KOH is added to a sample, thereby releasing volatile alkaline species into the gas phase. It should be noted, when considering the present invention as described below, that the sensors used in the investigation of Chandio et al are not sensitive to fatty acids such as acetic acid.

The present invention overcomes the above-mentioned problems and difficulties, and provides a quick, reliable and practical screening technique for the detection of bacterial vaginosis. The technique is easily automated and may be performed by unskilled operatives with a minimum of technical back-up.

For the avoidance of doubt, the terms "gas" and "gases" are understood to embrace all species present in the gas phase, including volatile species emanating from liquids and sublimed species emanating from solids.

According to a first aspect of the invention there is provided a method for detecting the presence of bacterial vaginosis in a female subject comprising the steps of:

obtaining a sample from the vaginal region of the subject;

detecting acetic acid present in the sample; and

correlating the presence of the detected acetic acid with the presence of bacterial vaginosis.

- 5 -

Surprisingly, acetic acid has been found to be a “marker” species indicative of BV, and has enabled the provision of a detection technique having the aforesaid advantages.

In a preferred embodiment, acetic acid present as a gas in a headspace associated with the sample is detected using a detector which is sensitive to the presence of acetic acid.

The sample may be a swab sample, and a high vaginal swab sample may be obtained. A high vaginal swab is a swab taken from the Posterior Fornix, any of the three vaulted spaces at the top of the vagina, or from around the cervix of the uterus. Thus, the sample can be “indirect”, in the sense that the sample comprises an object which is physically removed from the vaginal region of the subject to a sampling portion of the detector. Alternatively, it may be possible to sample gases directly from the vaginal region of the subject using the detector: this alternative is also within the scope of the invention.

Ammonia and, optionally, amine species (such as TMA) present in the sample may be detected, and the presence of acetic acid, ammonia and, optionally, amine species may be correlated with the presence of bacterial vaginosis. Preferably, ammonia and, optionally, amine species present as gas in the headspace associated with the sample are detected by the detector.

The detector may comprise semiconducting organic polymer.

The detector may comprise an array of gas sensors. An array, in the context of the present invention, is two or more gas sensors. In contrast to conventional electronic noses, it has been found that arrays having only a small number of physically different gas sensors can be used advantageously. For example, an array may comprise

five or fewer sensor types which are sensitive to acetic acid, and five or fewer sensor types which are sensitive to ammonia (and/or amines). As few as four different sensor types have been found to be sufficient. It may be possible to use a single acetic acid sensitive gas sensor in place of an array.

The array may comprise gas sensors having semiconducting organic polymer as a gas sensitive layer.

The detector may comprise at least one conductimetric gas sensor having a gas sensitive layer onto which gases absorb and desorb, and in which analytes are detected by:

exposing the gas sensor to the headspace, thereby allowing the adsorption of analytes present in the headspace onto the gas sensitive layer; and

making conductimetric measurements of the sensor during a desorption phase in which there is net desorption of analyte from the gas sensitive layer. This approach has been found to be extremely advantageous in terms of improving sensitivity and reproducibility. The principal reason for this is that the effect of water vapour appears to be substantially eliminated in the desorption phase. This is a considerable advantage, and significantly enhances the detection of fatty acids, ammonia and amines. However, it will be appreciated that this approach is not limited to the detection of these species, and nor is it limited to the method of the present invention. Rather, the approach of making conductimetric measurements in the desorption phase can be employed as a general technique for detecting analytes using conductimetric gas sensors which have a gas sensitive layer. Typically, a pulse of gas from the headspace is flowed over the sensor, and the desorption phase commences once this pulse of gas has finished flowing over the sensor. The technique of making conductimetric measurements in the

- 7 -

desorption phase works best when analytes of interest have significantly longer desorption times than water.

The conductimetric gas sensor or sensors may comprise semiconducting organic polymer.

This method may further comprise the steps of:

performing a data reduction of one or more measurements of one or more calibration samples to provide reference scores and reference loadings; and

performing data reduction of the output of the detector using the reference loadings.

In a preferred embodiment the data reduction comprises a principal components analysis (PCA). Other forms of data reduction, such as Sammon mapping, may be feasible.

This approach permits very convenient and quick assessment of whether a sample is infected on the basis of simple assessment criteria. Furthermore, it is possible to calibrate the system and to perform self-test protocols using this approach.

The reference scores and reference loadings may relate to a co-ordinate system having an axis which is correlated to the presence of acetic acid. The reference scores and reference loadings may relate to a co-ordinate system having one axis which is correlated to the presence of acetic acid and another axis which is correlated to the presence of ammonia and, optionally, amine species.

The method may be one in which:

the reference scores and reference loadings relate to a co-ordinate system having a species characteristic axis which is correlated to the presence of a species; and

data reduction of intensity data from the detector is performed using the reference loadings so that position along the species characteristic axis is related to the concentration in the headspace of the species which is correlated to the species characteristic axis. In this way the intensity data can be related to the concentration of marker species which in turn can be related to the number of infecting organisms. In particular, it is possible to observe if a threshold concentration has been crossed, allowing the correlation of detector output with the presence of infection to be made. It should be noted that in the prior art, intensity data from electronic noses comprising arrays of gas sensors are usually removed by normalisation before analysis such as PCA, so that concentration independent "fingerprints" can be obtained.

According to a second aspect of the invention there is provided a gas sensing system adapted to detect the presence of bacterial vaginosis in a female subject by the method of the first aspect of the invention comprising:

a detector which is sensitive to the presence of gaseous acetic acid and adapted to sample a headspace associated with the sample; and

analysis means for analysing the output of the detector and correlating the presence of detected acetic acid with the presence of bacterial vaginosis.

The analysis means may correlate the presence of acetic acid, ammonia and, optionally, amine species with the presence of bacterial vaginosis.

Methods and apparatus in accordance with the invention will now be described with reference to the accompanying drawings, in which:

- 9 -

- Figure 1 shows (a) a schematic diagram of apparatus suitable for identifying the presence of BV and (b) Sampling of a headspace:
- Figure 2 shows typical sensor responses a) to acetic acid of one polymer type and b) to ammonia of another polymer type as a function of time;
- Figure 3 shows a PCA transformation;
- Figure 4 shows a PCA calibration map;
- Figure 5 shows the calculation of projected PCA scores;
- Figure 6 is a graphical representation of ellipses projected onto the PCA calibration map; and
- Figure 7 is a graphical representation of the resolution of sample standard deviation along the PC1 - PC2 axes.

Figure 1(a) schematically depicts apparatus shown generally at 10, for use with the method of the present invention. The apparatus comprises a sample carousel 12 in which a number of sample vials can be mounted and maintained at a constant temperature, for example 40°C. For simplicity, a single sample vial 14 is shown in Figure 1(a). The vial 14 contains a sample 16 such as a swab taken from the vagina of a subject. Above the sample 16 is a gaseous headspace 18 which contains *inter alia* volatile species emanating from the sample 16.

The vial 14 has a septum 14a thereon which is pierced by a needle 20, the insertion of needle 20 into the vial 14 being performed automatically by the apparatus 10. The needle 20 is shown in more detail in Figure 1(b). The needle 20 is of co-axial design, which permits a carrier gas (such as air, nitrogen or a noble gas) to be introduced to vial 14 via the inner lumen 20a of the needle 20. Gases in the headspace 18 are entrained in the flow of carrier gas, which exits the vial 14 via the outer lumen 20b of the needle 20, and thereafter is flowed across a gas sensor array 22. In this way, the

- 10 -

headspace 18 is sampled by a gas detector 22, which in this embodiment is a gas sensor array. It will be appreciated by the skilled reader that there are many other ways in which the headspace might be coupled to a gas detector. It may be possible to directly sample gases from the vaginal region of a subject using a suitable arrangement, such as a sampling probe coupled to the gas detector. Additionally, the use of devices such as filters and preconcentrators is feasible.

The gas sensor array 22 is selected so that it can detect acetic acid. This species can be found to constitute a "marker" species which can be indicative of BV infection. Other species can be detected in order to augment the identification. Ammonia and amine species such as TMA can be detected for this purpose. It is possible that further "marker" species might be detected in addition to acetic acid.

The output of the gas sensor array 22 is monitored and analysed by control means 24 which comprise computer means or other microprocessor-based analysis means. The control means 24 can also control the operation of the carousel 12, the flow of carrier gas, washing and calibration procedures, and the manner in which the gas sensor array 22 is operated or interrogated. However, it is quite possible to transfer data from the control means 24 to, for example, a remote computer for analysis. In any event, some form of analysis means is provided which is adapted to correlate the presence of the detected acetic acid with the presence of the infection. In this way, the sample 14 is screened for BV infection.

The method of the present invention has been used to screen samples for BV infection. The human vagina is a host to many species of microorganisms, and the headspace associated with a vaginal sample is itself complex. It is known from WO 95/33848 that microorganisms can produce volatile species which are characteristic of the microorganisms. What is not known from WO 95/33848 is how, with a highly complex headspace associated with a vaginal sample, one can identify the presence of

BV infection from gases emanating from the sample. Furthermore, WO 94/04916 and Chandiok et al. are concerned with the detection of alkaline species such as ammonia and amines. The present invention overturns this conventional wisdom.

The pH of the sample can be lowered, by the addition of an acid in order to release acetic acid into the gaseous phase. However, it has been found that typically quite large concentrations of acetic acid are associated with positive BV samples (often at concentrations of 500 ppm or greater) and therefore acidification is not an essential element of the invention.

Optionally, a salt such as Na_2SO_4 can be added in order to displace less soluble volatiles, in particular organic species, from solution and into the gaseous phase. Backwashing between samples is advisable to prevent cross-contamination.

In a preferred embodiment, the gas detector is an array of gas sensors, and in a particularly preferred embodiment the gas sensors comprise semiconducting organic polymer gas sensors. However, in principle, other forms of gas detector might be employed, provided that they are sensitive to the marker species described above. Gas detection techniques which are candidates for use in the present invention include gas chromatography, mass spectrometry and spectroscopic techniques such as IR spectroscopy. Other forms of gas sensor array might be contemplated, such as arrays of metal oxide sensors, SAW sensors, quartz resonators, "composite" sensors of the type described generally in US 5571401, and arrays comprising mixtures thereof.

Embodiments of a preferred - but non-limiting-kind of gas detector will now be described, namely arrays of semiconducting organic polymer gas sensors. As discussed above, the traditional approach with such arrays is to employ a large number (typically twenty or more) of different sensors having different polymers and/or different dopant counterions, thus producing an array in which the individual gas sensors exhibit

- 12 -

broad and overlapping sensitivities towards a range of different gases. The same principle applies to other arrays of gas sensors, such as metal oxide sensors. Devices of this type are commonly referred to as “electronic noses”.

In direct contrast, it has been found that screening for infection according to the present invention can be advantageously performed using an array which comprises a limited number of sensor types, ie. sensors with physically different polymer/counterion combinations. In one example, four types of selective conducting polymer sensors have been developed and incorporated into a device. Two of these are acid sensitive, one sensitive to ammonia, and the other sensitive to ammonia and trimethyl amine. These four sensor types are incorporated into a 48 sensor array, comprising 12 sets of replicate sensors. The provision of 12 replicates of each sensor type permits signal averaging over a large number of sensors. Additionally, sets of replicate sensors allows the array to function in the event that one or even more than one sensor in any given replicate set malfunctions. Fewer sensors still might be utilised, particularly if acetic acid alone is detected as a “marker”.

The changes in resistance of each sensor type in response to a volatile sample are recorded with time, and are averaged for each sensor type over the array. It has been observed that it is possible to eliminate the effect of water vapour on the response of the sensors by choosing a portion of the trace corresponding to the desorption phase of the experiment. With acetic acid as the analyte, it has been observed that there is undershoot in the signal below the previous baseline (see Figure 2a). This effect is reproducible, is a function of concentration of acetic acid, and is a parameter due to the type of materials incorporated into the sensor. The time course is primarily dependent on the sensor kinetics, but carrier flow and header geometry will also have an effect.

Figure 2a shows a number of response profiles to acetic acid for a semiconducting organic polymer sensor against time. The baseline response is indicated

at "A". During the period of time indicated as "B", the sensors are exposed to a pulse of gas comprising acetic acid entrained in a carrier gas. This can be regarded as an "adsorption phase" during which there is net adsorption of acetic acid - and water - onto the sensors. After the gas pulse has finished, there is a desorption phase, or recovery phase, which is indicated as "C", during which there is a net desorption of analyte from the sensors. It can be seen that the response becomes negative with respect to the baseline during the recovery phase. With fatty acid analytes, signal averaged over the period C is a function of the concentration of acid present in the headspace. The responses shown at "D" and "E" relate to (standard) wash and reference cycles, respectively.

It should be noted that generally similar responses are obtained when the sensors are exposed to ammonia (Figure 2b), ie. there are distinct baseline, adsorption and recovery phases. However, the response in the recovery phase in this instance remains positive with respect to the baseline. Measurements made during the recovery phase are also substantially free from interferences from moisture.

Interference from moisture is a major limitation for a number of gas sensing technologies which interrogate a gas sensitive layer of some kind upon which analytes - and water vapour - can reversibly adsorb. Semiconducting organic polymers are an example of such a gas sensitive layer. The above described technique for rejecting interfering signals due to moisture is of broad significance - not only is the technique applicable in the context of screening for BV infection, it can be utilised more widely in the detection of analytes *per se*.

It is believed that the displacement of the sensor response from the baseline during the recovery phase is a result of the analyte still being bound at the polymer surface. As a result of interactions between the bound analyte and the electronic structure of the polymer, the polymer can be more doped (producing a negative response)

or less doped (producing a positive response) than when the baseline measurements were made. It is believed that water desorbs from the polymer surface very rapidly during the recovery phase, and so most of the recovery phase is substantially moisture free. However, these mechanisms are speculative in nature, and should not be regarded as a limiting one.

It should be noted that analysis of the sensor response is not restricted to the recovery phase. In an alternative configuration the resistances recorded when the sensors are exposed to the headspace from the sample (ie, the sample phase) could be compared to the resistances recorded for an equivalent exposure to a threshold standard. By determining whether the sample resistance lies above or below the resistance values for the threshold standard the BV diagnosis can be made. In this configuration the calibration requirements for the system may be greatly reduced.

It should be noted that, whilst prior art semiconducting organic polymer gas sensors generally show good sensitivity towards ammonia, it has not previously been possible to detect fatty acids such as acetic acid at low concentrations using such gas sensors. The present invention provides new gas sensors which employ new semiconducting organic polymers. With these polymers, high sensitivity towards fatty acids (such as acetic acid) and ammonia can be achieved.

The new materials have a bilayer structure with a baselayer of polypyrrole deposited chemically using ferric chloride as an oxidant. Different sensor types are manufactured by electrochemically depositing different top layer polymers onto this baselayer. The four types of sensors incorporated into the device described above use the following monomer/electrolyte combinations for the electrochemical deposition stage:

1. 3-Hexanoylpyrrole/tetraethylammonium *p*-toluenesulphonate

2. 1-Octylpyrrole/tetrabutylammonium triflate
3. 3-Dodecylpyrrole/Tetraethylammonium tetrafluoroborate
4. 1-Dodecylpyrrole/Tetraethylammonium tetrafluoroborate

The 3-substituted monomers can be synthesised following the method of Ruhe et al (Makromol, Chem., Rapid Commun. 10 (1989) 103). The 1-substituted monomers can be synthesised following the method of Santaniello et al (Synthesis, 1979, 617).

Further details of the polymerisation conditions and of the preparation of polymer bilayers having a baselayer of polypyrrole can be found in the Applicant's earlier International Publication WO 96/00383.

In a typical procedure, the sample is equilibrated at 40°C for ca. 3 minutes prior to sampling to allow a consistent generation of the sample headspace. Nitrogen gas is humidified to 50% relative humidity and introduced into the sample vial directly above the surface of the swab. The sample headspace is delivered to the sensor array for 3 minutes at a flow rate of ca. 60mlmin⁻¹. The sensor array is allowed to recover for a few minutes before a "wash" gas, preferably a high concentration acetic acid wash, is passed over the sensor typically for 1 to 4 minutes.

Data Processing

An object of the invention is to produce a rapid screening system for BV. The embodiment described below utilises the acetic acid, ammonia and TMA sensitive sensor array described above and is capable of making a decision based on the relative intensities of acetic acid and/or ammonia and TMA present in the headspace. Analysis of the sensor array has been greatly facilitated by a novel data processing technique which is discussed below and which is based on principal components analysis (PCA -

see, for example, J E Jackson, J Qual. Tech., 13(1) (1981)). It has been established that if a principal components analysis of the intensity data from the highly orthogonal sensors is carried out, the distribution of points projected on a first principal components axis PC 1 is correlated to acetic acid, and that the points projected on a second principal components axis PC 2 are correlated to ammonia. The distribution along either coordinate axis is also a function of the concentration of the analyte in the headspace, and hence of the concentration of marker chemicals produced by the microorganisms present in the sample. Thus it is possible to utilise a thresholding technique for deciding whether or not a sample is positive or negative, based on user-defined clinical criteria. In broad terms, the data processing comprises using calibration samples to establish a PCA “calibration map”, and then projecting data obtained from enclosed samples onto this PCA calibration map in order to establish if these data are indicative of infection.

Data processing is described in more detail below, with reference to various calibration and measurement process which are performed.

1. Calibration

Calibration involves running calibration standards to generate a reference map, verifying results and storing PCA loadings information.

In one example the array is calibrated using defined standards consisting of a “blank” sample, two acetic acid standards of different concentrations, and ammonium hydroxide. Typically, the calibration process is accompanied by repeatability checks on the standards in order to verify that there is sufficient discrimination between standards and that repeatability is within acceptable bounds. 1ml sample volumes are used as above. As part of each experimental run, subsets of standards are run, each sample cycle lasting 20 minutes. In preferred, but non-limiting, embodiments, the blank is water, one acetic acid standard comprises 900ppm acetic acid in 0.01M HCl, the other acetic acid

standard is 5000ppm acetic acid in 0.01MHCl, and the ammonium hydroxide standard is 10ppm in 0.01 M NaOH. The subset of standards can be used to confirm that the performance of the system is still the same as during its calibration and hence that the samples can be processed.

1.a. Calibration Map

The calibration data is transformed using Principal Component Analysis (PCA) to characterise the instrument sensor responses for the calibrants run, thus defining a two-dimensional mapping space on to which all subsequent samples analysed can be projected. PCA decomposes the original calibrant data matrix into a set of scores and loading vectors, in which scores contain information of how samples relate to one another whilst the loadings show how variables relate to one another. This process is depicted in Figure 3, and can be written as:

$$X = t \times p^T$$

where t denotes the scores, which are vectors of linear combinations of sensor variables that describe the major trends in the original data matrix X . The loadings, which are represented by p , are a set of orthonormal eigenvectors representing a new set of axes onto which the scores information is projected. In Figure 3 T denotes the transpose of a matrix. The result is a “calibration map” which is shown in Figure 4.

Projected scores (PC1 and PC2) can be calculated by multiplying the analysis results with the reference loadings calculated in the calibration step. This process is depicted in Figure 5.

1.b. Setting Thresholds

In the following discussion, Blk is the water standard referred to above, Std1 is the lower concentration acetic acid standard, Std2 is the higher concentration

acetic acid standard referred to above, and Std3 is the ammonium hydroxide standard referred to above. Std1 and Std3 correspond to the threshold concentrations of acetic acid and ammonium, respectively, above which infection is considered to be present.

It is possible to set threshold levels which, if exceeded, are taken to be indicative of infection. A relatively straightforward way of doing this is to define a threshold PC1 value and a threshold PC2 value. However, the present invention provides an improved thresholding technique which generates an ellipse, and utilises the boundaries of the generated ellipse as a threshold. An advantage with the use of an ellipse for this purpose is that the effects of sensor drift, which inevitably occurs over a period of time, can be taken into account.

An ellipse is defined by the five parameters, r , s' , c , d , θ_r , where:

r is the radius of the major axis

s' is the radius of the minor axis

c and d relate to the coordinates of the centre of the ellipse

and

θ_r is the angle of rotation between the positive x axis, and the axis radii established by Std1.

More specifically, an ellipse can be expressed algebraically in the form:

$$Ax^2 + By^2 + Cx + Dy + Exy + F = 0$$

- 19 -

Where A,B,C,D,E and F are constant terms the values of which are determined by the parameters ($r, s', c, d, M(\theta_r), N(\theta_r)$) such that:

$$A = s'^2 M^2 + r^2 N^2$$

$$B = s'^2 N^2 + r^2 M^2$$

$$C = -2(s'^2 M c + r^2 N d)$$

$$D = 2(s'^2 N c - r^2 M d)$$

$$E = -2(s'^2 M N - r^2 M N)$$

$$F = s'^2 c^2 + r^2 d^2 - r^2 s'^2$$

The parameters $M(\theta_r)$ and $N(\theta_r)$ are defined below and are dependent on θ_r .

The five parameters r, s', c, d, θ_r can be determined from the set of calibration data. Figure 6 shows the two dimensional PCA reference map with the Blk 60, Std1 62, Std2 64 and Std3 66 calibration data projected thereon. Figure 6 also depicts the parameters r, s and θ_r and the resultant ellipse 68.

Each calibration sample is defined by a score (t_1, t_2) value along each principal component axes PC1 and PC2, while (\bar{t}_1, \bar{t}_2) denotes the mean score for a set of n -repeats of a chemical standard X. The length s' is the resolved distance (between the mean scores for *Std3* and the mean scores for *Blk*) orthogonal to vector \vec{r} determined by vector \vec{s} which is at an angle ϕ to vector \vec{r} .

The five parameters r, s', c, d, θ_r are calculated as follows:

Angle of Rotation θ

From Figure 6 the angle θ is defined as;

$$\theta_r = \left| \tan^{-1} \left(\frac{\overline{t2}_{Std1} - \overline{t2}_{Blk}}{\overline{t1}_{Std1} - \overline{t1}_{Blk}} \right) \right| \quad (1)$$

which is calculated in radians.

Parameters *c* and *d* (a function of the Blk Centre)

The mean score of the *Blk* ($\overline{t1}_{blk}, \overline{t2}_{blk}$) standards defines the centre of the ellipse. The parameters *c* and *d* which are functions of both $\overline{t1}_{blk}$ and $\overline{t2}_{blk}$ are calculated as follows:

$$\begin{bmatrix} c \\ d \end{bmatrix} = \begin{bmatrix} \cos(-\theta_r) & -\sin(-\theta_r) \\ \sin(-\theta_r) & \cos(-\theta_r) \end{bmatrix} \times \begin{bmatrix} \overline{t1}_{blk} \\ \overline{t2}_{blk} \end{bmatrix} \quad (2)$$

Axis radii (*r*)

The length *r* is calculated as follows:

$$r = \sqrt{(\overline{t1}_{Std1} - \overline{t1}_{blk})^2 + (\overline{t2}_{Std1} - \overline{t2}_{blk})^2} \quad (3)$$

where *r* is the Euclidean distance separation between the mean scores for *Std1* ($\overline{t1}_{Std1}, \overline{t2}_{Std1}$) and mean scores *Blk* ($\overline{t1}_{blk}, \overline{t2}_{blk}$).

Axis radii (*s'*)

The general equation of an ellipse centred at ($\overline{t1}_{blk}, \overline{t2}_{blk}$) with axis radii (*r,s'*) rotated at an angle θ_r from the positive x-axis can be written as follows:

$$\frac{(X - Y - c)^2}{r^2} + \frac{(X + Y - d)^2}{(s')^2} = 1 \quad (4)$$

Where:

$$M = \cos(-\theta_r)$$

$$N = \sin(-\theta_r)$$

x = x-coordinate lying on the ellipse

y = y-coordinate lying on the ellipse

By re-arranging equation (4) the length of s' can be determined for known values of c , d , r , θ_r and a point lying on the boundary of the ellipse. The (x,y) coordinates in equation (4) are defined by the mean score of \mathcal{SB} ($\bar{t1}_{sd_1}$, $\bar{t2}_{sd_2}$) such that:

$$s' = \sqrt{\frac{r^2 (N\bar{t1}_{sd_1} + M\bar{t2}_{sd_2} - d)^2}{r^2 - (M\bar{t1}_{sd_1} - N\bar{t2}_{sd_2} - c)^2}} \quad (5)$$

In general, a number of calibration measurements are made, and some variation in the recorded responses is observed. This data scatter is depicted in Figure 6. It is possible to account for this variation in the recorded responses for the calibration standards by calculating a confidence band around the ellipse. To achieve this the variability sd_r and sd_s along the response vectors \vec{r} and \vec{s} for the axis radii parameters are calculated.

Calculation of sd_r and sd_s along \vec{r} and \vec{s} for the axis radii parameters.

- 22 -

A standard deviation value can be calculated for each standard $Std1$, $Std3$ along each component axis. This can be resolved as shown in Figure 7 below to provide an estimate for the standard deviation (sd) along the vector component \bar{r} and \bar{s} .

The resultant sd (κ_r) along $\bar{r}(Std1)$ is:

$$\kappa_r = \sqrt{sd_{11}^2 + sd_{12}^2} \quad (6a)$$

and the resultant sd (κ_s) along $\bar{s}(Std3)$ is:

$$\kappa_s = \sqrt{sd_{31}^2 + sd_{32}^2} \quad (6b)$$

Where sd_{11} is SD along PC1 and sd_{12} is SD along PC2.

The standard deviation along vector \bar{r} (or \bar{s}) is given by:

$$sd_r = \kappa_r \times \cos(|\theta_r - \psi_r|) \quad (7a)$$

$$sd_s = \kappa_s \times \cos(|\theta_s - \psi_s|) \quad (7b)$$

where:

$$\theta_r = \left| \tan^{-1} \left(\frac{\bar{t2}_{Std1} - \bar{t2}_{Blk}}{\bar{t1}_{Std1} - \bar{t1}_{Blk}} \right) \right|$$

$$\psi_r = \tan^{-1} \left(\frac{sd2_{Std1}}{sd1_{Std1}} \right)$$

- 23 -

$$\theta_s = \left| \tan^{-1} \left(\frac{\bar{t}2_{Std3} - \bar{t}2_{Blk}}{\bar{t}1_{Std3} - \bar{t}1_{Blk}} \right) \right|$$

$$\psi_s = \tan^{-1} \left(\frac{sd2_{Std3}}{sd1_{Std3}} \right)$$

Having established sd_r and sd_s along the response vectors \vec{r} and \vec{s} , the upper and lower lengths for \vec{r} and \vec{s} can be calculated at the desired confidence level such that:

$$(U_r, L_r) = r \pm t_{\alpha/2, \nu} (sd_r / \sqrt{n_r}) \quad (8)$$

$$(U_s, L_s) = s \pm t_{\alpha/2, \nu} (sd_s / \sqrt{n_s}) \quad (9)$$

The confidence level (α) is calculated for two-tailed t-statistic for ν degrees of freedom, where $\nu = n-1$ for n -repeats of each standard calibrant.

Before the equations for the upper and lower confidence bands can be established the coordinates for the lengths U_s and L_s are determined.

Calculating the PC scores for a point lying along the vector \vec{s} whose length is U_s and L_s from the ellipse centre.

Vector \vec{s} can be written as:

$$\vec{s} = a\vec{i} + b\vec{j} \quad (10)$$

Where

- 24 -

$$a = \overline{t1_{SA}} - \overline{t1_{BA}}$$

$$b = \overline{t2_{SA}} - \overline{t2_{BA}}$$

The length of \vec{s} is given below:

$$|\vec{s}| = \sqrt{a^2 + b^2}$$

The PC scores for a length P along \vec{s} can be calculated as follows:

$$\begin{aligned} tl_p &= F\bar{a} + \overline{t1_{BA}} \\ \ell_p &= F\bar{b} + \overline{t2_{BA}} \end{aligned} \quad (11)$$

Where F is a multiplication factor and is defined as:

$$F = \frac{P}{|\vec{s}|}$$

Note that for P we can substitute the lengths U_s and L_s in order to determine the corresponding co-ordinates for U_s' and L_s' , respectively, from equation (11). U_s' and L_s' are calculated as follows:

$$L_s' = \sqrt{\frac{(Lr)^2 (Nt1_{L_s} + Mt2_{L_s} - d)^2}{(Lr)^2 - (Mt1_{L_s} - Nt2_{L_s} - c)^2}}$$

$$U_s' = \sqrt{\frac{(Ur)^2 (Nt1_{U_s} + Mt2_{U_s} - d)^2}{(Ur)^2 - (Mt1_{U_s} - Nt2_{U_s} - c)^2}}$$

2. Classification

Once the parameters $(U_r, c, d, \theta_r, U_s'(\alpha))$ and $(L_r, c, d, \theta_r, L_s'(\alpha))$ have been determined, the equations representing the upper and lower confidence intervals for the ellipse can be defined. Real data are projected onto the PCA calibration map and compared to the ellipse generated from the calibration data.

The present inventors prefer to utilise the boundary of the ellipse itself as the threshold for classifying a sample as being positive. In other words, if a sample produces a PCA result which lies within the ellipse, it is classified as negative, whereas if a sample produces a PCA result which lies outside the ellipse, it is classified as positive for BV. However, the skilled reader will appreciate that there are sundry variations in the way in which the threshold might be set. For example, the lower confidence intervals of the ellipse might be used as the threshold.

3. System Verification

Calibration standards are run on the system at regular intervals. This process is known as a system verification process. Sensor responses can vary over a period of time, and this response variation is often manifest as a rotation of Std1, Std2, and Std3 responses about the origin of the PCA calibration map. An advantage with the use of an ellipse to define threshold values (as opposed to, for example, a linear threshold on either PC axis) is that such rotation can be accommodated. However, it is possible that sensor drift (or other factors) may cause so large a shift in sensor response that the Std1 and Std3 responses are unacceptably far removed from the ellipse when these responses are transferred onto the PCA calibration map. In this instance, the entire process can be repeated, and a new PCA calibration map generated. A system verification process is now described.

A lower limit ellipse classification boundary (LECB) and an upper limit ellipse classification boundary (UECB) are useful parameters in conducting system verification checks. The algebraic expression describing the LECB and UECB can be determined by the following sets of parameters, such that:

$$\text{LECB}[L_r(\text{NS}_r), L_s'(\text{NS}_s), c, d, \theta_r]$$

$$\text{UECB}[U_r(\text{NS}_r), U_s'(\text{NS}_s), c, d, \theta_r]$$

Note that the parameters c, d , and θ_r are already calculated.

Calculating L_r and U_r

L_r and U_r are functions of the NS_r parameter which is expressed in standard deviation units from the mean of the Std1 standard along vector \vec{r} .

$$L_r = r - \text{NS}_r \times \text{sd}_r \quad (12)$$

$$U_r = r + \text{NS}_r \times \text{sd}_r \quad (13)$$

Calculating the PC coordinates for lengths L_s and U_s along \vec{s} .

L_s and U_s are both functions of the NS_s parameter which is expressed in standard deviation units from the mean of the Std3 standard along vector \vec{s} .

$$L_s = s - \text{NS}_s \times \text{sd}_s \quad (14)$$

$$U_s = s + \text{NS}_s \times \text{sd}_s \quad (15)$$

\vec{s} can be written in vector notation as:

$$\vec{s} = a_i + b_j$$

- 27 -

where $a = \bar{t1}_{Std3} - \bar{t1}_{Blk}$ and $b = \bar{t2}_{Std3} - \bar{t2}_{Blk}$ (See equation 10)

The PC1 and PC2 coordinates for the length L_s and U_s along vector \vec{s} is calculated as follows:

$$t1_{L_s} = \left(\frac{L_s}{s} \right) a + \bar{t1}_{Blk} \quad (16)$$

$$t2_{L_s} = \left(\frac{L_s}{s} \right) b + \bar{t2}_{Blk} \quad (17)$$

$$t1_{U_s} = \left(\frac{U_s}{s} \right) a + \bar{t1}_{Blk} \quad (18)$$

$$t2_{U_s} = \left(\frac{U_s}{s} \right) b + \bar{t2}_{Blk} \quad (19)$$

Calculating L_s' and U_s'

$$L_s' = \sqrt{\frac{(Lr)^2 (Nt1_{L_s} + Mt2_{L_s} - d)^2}{(Lr)^2 - (Mt1_{L_s} - Nt2_{L_s} - c)^2}} \quad (20)$$

$$U_s' = \sqrt{\frac{(Ur)^2 (Nt1_{U_s} + Mt2_{U_s} - d)^2}{(Ur)^2 - (Mt1_{U_s} - Nt2_{us} - c)^2}} \quad (21)$$

where values for M and N are as calculated earlier.

The LECB and UECB is used during system verification. In one embodiment, a number of Std1, Std3 and Blk standards are run. Std1 and Std3 standards should produce PCA results which lie within the interval defined by the LECB and UECB, ie, outside the LECB but inside the UECB. The Blk standards should produce PCA results which lie within the LECB. An acceptable protocol is to run three Std1, three Std3 and three Blk, and to require that all of the Blk standards, at least two of the Std1 and at least two of the Std3 standards satisfy these criteria. If this is not the case, then the system should be recalibrated. The system verification can be performed at any suitable juncture, such as before a batch of samples is analysed or perhaps on a daily basis.

Variants to the scheme described above would suggest themselves to the skilled reader. For example, samples may be separated and classified using Mahalanobis distance measure. Other forms of data reduction than Principle Components Analysis might be used, such as Sammon Mapping. In principle, more than two principal components might be used to construct the calibration map. Such an approach may not be of great advantage in the context of the technique for detecting BV discussed above. However, the data processing principles discussed above may be applicable to the analysis of gas sensors in other application areas and the approach may even be applicable beyond the field of gas sensors, perhaps to the analysis of data from combinations of other kinds of sensor, or to multivariate data analysis *per se*. In the instance where acetic acid alone is being detected as a “marker” for BV, it may be appropriate to utilise a single PCA axis, i.e., to consider a single principal component. Other forms of data analysis, such as neural networks or chemometric techniques, might be used. It will be appreciated by the skilled reader that, although the calibration map is a useful device for visually displaying the results of calibration and subsequent real data, for the purposes of calculating whether a sample is positive or negative it is not essential to display such a map. Rather, the method of performing data reduction to provide calibration loadings which are used to transform the output of the detector so that

an assessment of whether BV is present can be performed entirely in software, without actually constructing a map *per se*.

Instead of detecting gaseous and volatile species in the gas phase, it may be possible to perform measurements in the liquid phase. Spectroscopic techniques such as infra-red spectroscopic might be used. Alternatively, continuous flow methods, electrochemical techniques, or analysis by measurement of electrical impedance, such as described in International Publication No. WO 98/96985, might be contemplated.

CLAIMS

1. A method for detecting the presence of bacterial vaginosis in a female subject comprising the steps of:

obtaining a sample from the vaginal region of the subject;

detecting acetic acid present in the sample; and

correlating the presence of detected acetic acid with the presence of bacterial vaginosis.

2. A method according to claim 1 in which acetic acid present as a gas in a headspace associated with the sample is detected using a detector which is sensitive to the presence of acetic acid.

3. A method according to claim 1 or claim 2 in which the sample is a swab sample.

4. A method according to claim 3 in which a high vaginal swab sample is obtained.

5. A method according to any previous claim in which ammonia and, optionally, amine species present in the sample are detected, and the presence of detected acetic acid, ammonia and, optionally, amine species is correlated with the presence of bacterial vaginosis.

6. A method according to claim 5 when dependent on claim 2 in which ammonia and, optionally, amine species present as gas in the headspace associated with the sample are detected by the detector.
7. A method according to any of claim's 2 to 6 in which the detector comprises an array of gas sensors.
8. A method according to claim 7 in which the array comprises gas sensors having semiconducting organic polymer as a gas sensitive layer.
9. A method according to any of claim's 2 to 8 in which the detector comprises semiconducting organic polymer.
10. A method according to any of claim's 2 to 9 in which the detector comprises at least one conductimetric gas sensor having a gas sensitive layer onto which gases adsorb and desorb, and in which analytes are detected by:
 - exposing the gas sensor to the headspace, thereby allowing the adsorption of analytes present in the headspace onto the gas sensitive layer; and
 - making conductimetric measurements of the sensor during a desorption phase in which there is net desorption of analyte from the gas sensitive layer.
11. A method according to claim 10 in which the conductimetric gas sensor or sensors comprise semiconducting organic polymer.
12. A method according to any of claim's 2 to 11 in which:
 - data reduction of one or more measurements of one or more calibration samples is performed to provide reference scores and reference loadings; and
 - data reduction of the output of the detector performed using the reference loadings.

13. A method according to claim 12 in which the data reduction comprises a principal components analysis.
14. A method according to claim 12 or claim 13 in which the reference scores and reference loadings relate to a co-ordinate system having an axis which is correlated to the presence of acetic acid.
15. A method according to claim 14 in which the reference scores and reference loadings relate to a co-ordinate system having one axis which is correlated to the presence of acetic acid and another axis which is correlated to the presence of ammonia and, optionally, amine species.
16. A method according to any of claims 12 to 15 in which:
the reference scores and reference loadings relate to a co-ordinate system having a species characteristic axis which is correlated to the presence of a species; and
data reduction of intensity data from the detector is performed using the reference loadings so that position along the species characteristic axis is related to the concentration in the headspace of the species which is correlated to the species characteristic axis.
17. A gas sensing system adapted to detect the presence of bacterial vaginosis in a female subject by a method according to any of claims 1 to 16 comprising:
a detector which is sensitive to the presence of gaseous acetic acid and adapted to sample a headspace associated with the sample; and
analysis means for analysing the output of the detector and correlating the presence of detected acetic acid with the present of bacterial vaginosis.

- 33 -

18. A gas sensing system according claim 17 in which the analysis means correlates the presence of acetic acid, ammonia and, optionally, amine species with the presence of bacterial vaginosis.

1/4

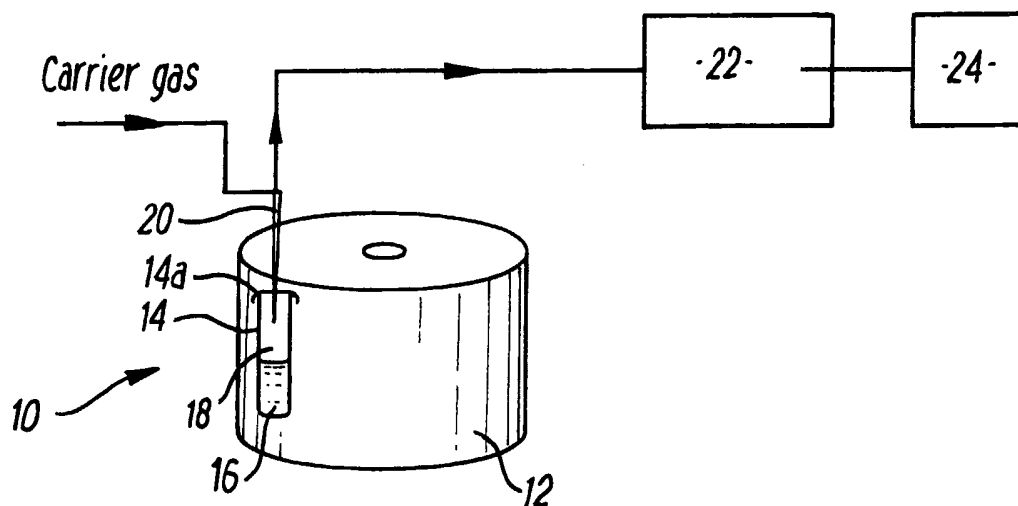

FIG. 1(a)

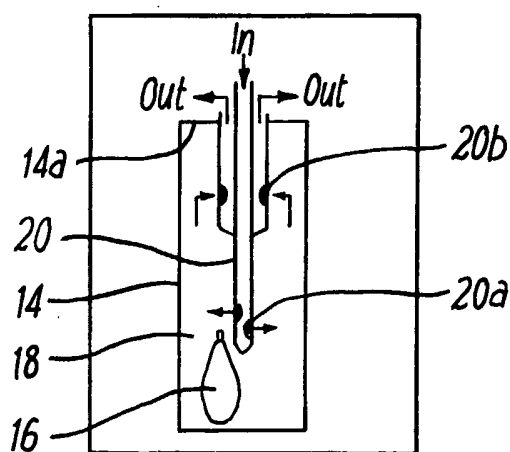

FIG. 1(b)

2/4

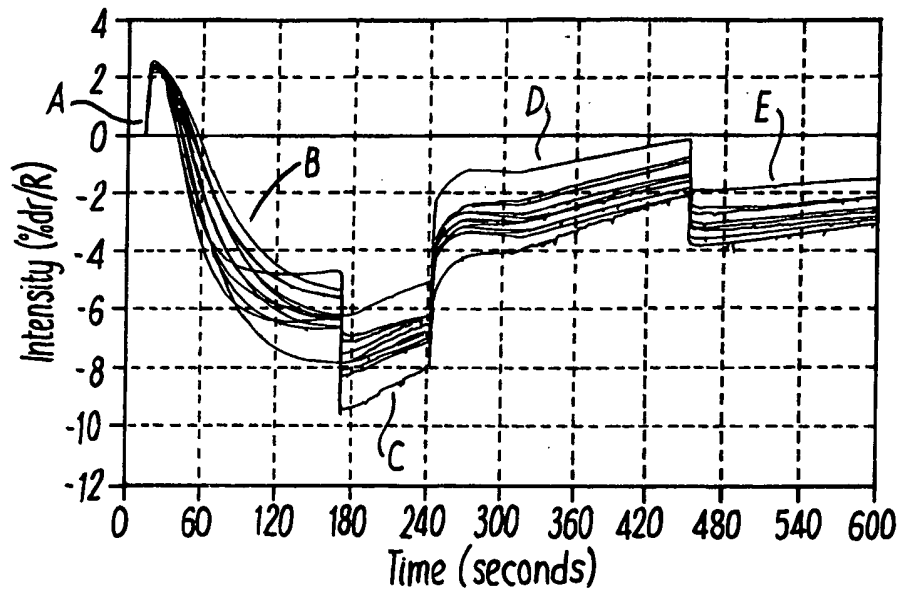

FIG. 2(a)

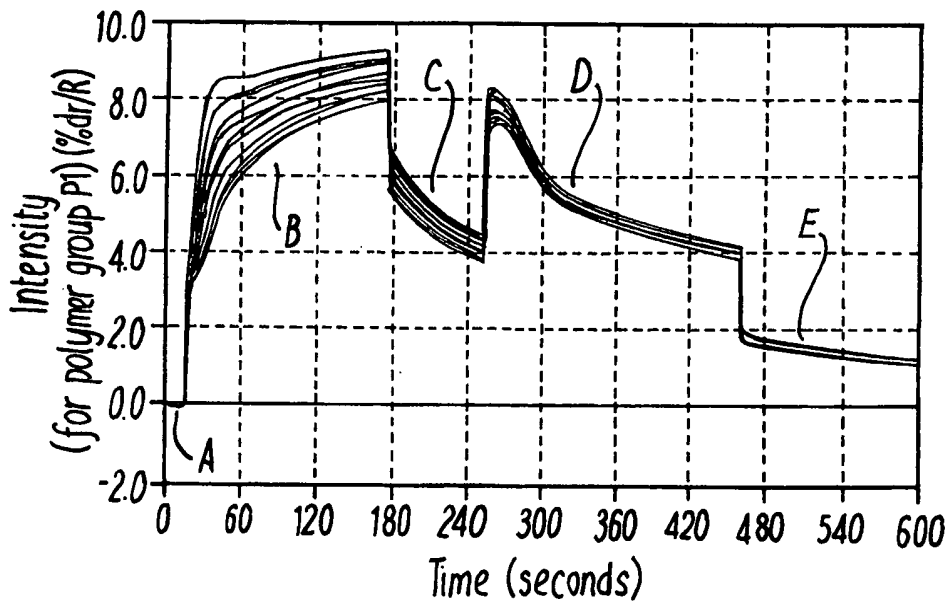

FIG. 2(b)

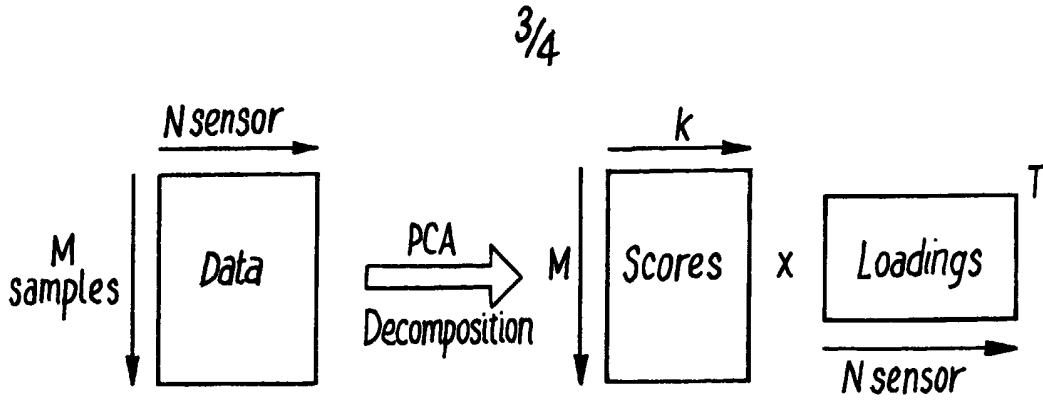

FIG. 3

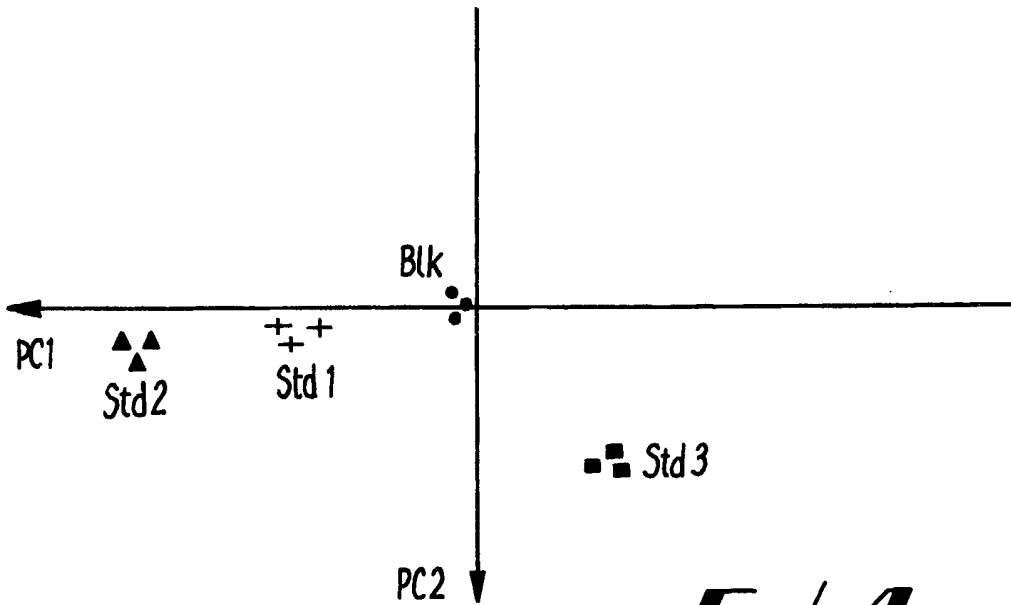

FIG. 4

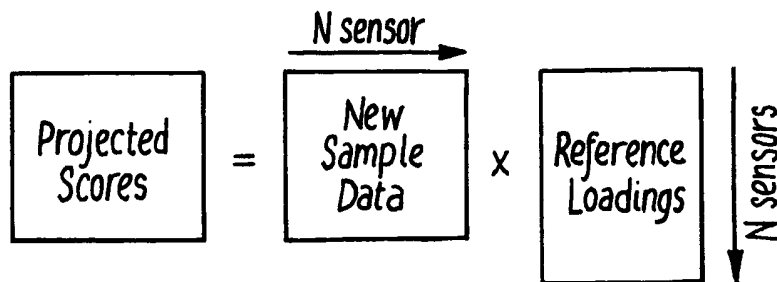

FIG. 5

INTERNATIONAL SEARCH REPORT

International Application No
PCT/GB 02/03818

A. CLASSIFICATION OF SUBJECT MATTER
IPC 7 C12Q1/00

According to International Patent Classification (IPC) or to both national classification and IPC

B. FIELDS SEARCHED

Minimum documentation searched (classification system followed by classification symbols)
IPC 7 C12Q

Documentation searched other than minimum documentation to the extent that such documents are included in the fields searched

Electronic data base consulted during the international search (name of data base and, where practical, search terms used)

EPO-Internal, PAJ, BIOSIS, WPI Data, EMBASE, MEDLINE

C. DOCUMENTS CONSIDERED TO BE RELEVANT

Category *	Citation of document, with indication, where appropriate, of the relevant passages	Relevant to claim No.
X	WO 01 13087 A (CALIFORNIA INST OF TECHN) 22 February 2001 (2001-02-22)	17, 18
Y	page 9, line 17 -page 12, line 25; claims 25-30; table 3	1-16
X	US 5 425 869 A (NODING STEPHEN A ET AL) 20 June 1995 (1995-06-20) column 9, line 48-65; figures 1,5-7	17, 18

Further documents are listed in the continuation of box C.

Patent family members are listed in annex.

* Special categories of cited documents :

- *A* document defining the general state of the art which is not considered to be of particular relevance
- *E* earlier document but published on or after the international filing date
- *L* document which may throw doubts on priority claim(s) or which is cited to establish the publication date of another citation or other special reason (as specified)
- *O* document referring to an oral disclosure, use, exhibition or other means
- *P* document published prior to the international filing date but later than the priority date claimed

- *T* later document published after the international filing date or priority date and not in conflict with the application but cited to understand the principle or theory underlying the invention
- *X* document of particular relevance; the claimed invention cannot be considered novel or cannot be considered to involve an inventive step when the document is taken alone
- *Y* document of particular relevance; the claimed invention cannot be considered to involve an inventive step when the document is combined with one or more other such documents, such combination being obvious to a person skilled in the art.
- *&* document member of the same patent family

Date of the actual completion of the international search

25 November 2002

Date of mailing of the international search report

03/12/2002

Name and mailing address of the ISA
European Patent Office, P.B. 5818 Patentlaan 2
NL - 2280 HV Rijswijk
Tel. (+31-70) 340-2040, Tx. 31 651 epo nl,
Fax: (+31-70) 340-3016

Authorized officer

Stachowiak, O

INTERNATIONAL SEARCH REPORT

International Application No

PCT/GB 02/03818

C.(Continuation) DOCUMENTS CONSIDERED TO BE RELEVANT		
Category *	Citation of document, with indication, where appropriate, of the relevant passages	Relevant to claim No.
Y	<p>STANEK RONALD ET AL: "High performance ion exclusion chromatographic characterization of the vaginal organic acids in women with bacterial vaginosis." BIOMEDICAL CHROMATOGRAPHY, vol. 6, no. 5, 1992, pages 231-235, XP001120274 ISSN: 0269-3879 page 234, right-hand column, paragraph 2 abstract; table 2</p>	1-16
A	<p>SPiegel C A ET AL: "MOBILUNCUS NEW-GENUS MOBILUNCUS-CURTISII-SSP-CURTISII NEW-SUBSPECIES MOBILUNCUS-CURTISII-SSP-HOLMESII NEW-SUBSPECIES AND MOBILUNCUS-MULIERIS NEW-SPECIES CURVED RODS FROM THE HUMAN VAGINA" INTERNATIONAL JOURNAL OF SYSTEMATIC BACTERIOLOGY, vol. 34, no. 2, 1984, pages 177-184, XP001120273 ISSN: 0020-7713 abstract</p>	1-18
A	<p>CHANDIOK S ET AL: "SCREENING FOR BACTERIAL VAGINOSIS: A NOVEL APPLICATION OF ARTIFICIAL NOSE TECHNOLOGY" JOURNAL OF CLINICAL PATHOLOGY, LONDON, GB, vol. 50, 1997, pages 790-791, XP002939203 ISSN: 0021-9746 cited in the application page 790, column 1-2; figure 1</p>	1-18
A	<p>CRAWLEY B A ET AL: "Microbial growth, antibiotic sensitivity patterns and the electronic nose." ABSTRACTS OF THE GENERAL MEETING OF THE AMERICAN SOCIETY FOR, vol. 99, 1999, page 121 XP001120271 99th General Meeting of the American Society for Microbiology; Chicago, Illinois, USA; May 30-June 3, 1999, 1999 ISSN: 1060-2011 abstract</p>	1-18
A	<p>XU CLARKE X ET AL: "Development of a diamine biosensor." TALANTA, vol. 44, no. 9, 1997, pages 1625-1632, XP001120249 ISSN: 0039-9140 abstract; figures 1,2</p>	1-18
	-/--	

INTERNATIONAL SEARCH REPORT

International Application No

PCT/GB 02/03818

C.(Continuation) DOCUMENTS CONSIDERED TO BE RELEVANT		
Category *	Citation of document, with indication, where appropriate, of the relevant passages	Relevant to claim No.
A	<p>WO 94 04916 A (BOLBOT JOHN ANTHONY; COSTA ERIC JOSEPH D (GB); STEWART DUNCAN (GB)) 3 March 1994 (1994-03-03) cited in the application the whole document</p> <p style="text-align: center;">---</p>	1-18
A	<p>PATENT ABSTRACTS OF JAPAN vol. 013, no. 294 (P-894), 7 July 1989 (1989-07-07) & JP 01 074442 A (FUJITSU LTD), 20 March 1989 (1989-03-20) abstract</p> <p style="text-align: center;">---</p>	10-18
A	<p>PATENT ABSTRACTS OF JAPAN vol. 013, no. 070 (P-829), 17 February 1989 (1989-02-17) & JP 63 255653 A (TOSHIBA CORP; OTHERS: 02), 21 October 1988 (1988-10-21) abstract</p> <p style="text-align: center;">-----</p>	10-18

INTERNATIONAL SEARCH REPORT

Information on patent family members

International Application No

PCT/GB 02/03818

Patent document cited in search report		Publication date	Patent family member(s)	Publication date
WO 0113087	A	22-02-2001	WO 0113087 A2	22-02-2001
US 5425869	A	20-06-1995	AU 4049393 A	18-11-1993
			CA 2118521 A1	28-10-1993
			EP 0637382 A1	08-02-1995
			JP 7505952 T	29-06-1995
			WO 9321522 A1	28-10-1993
WO 9404916	A	03-03-1994	AU 4723193 A	15-03-1994
			EP 0655133 A1	31-05-1995
			WO 9404916 A1	03-03-1994
JP 01074442	A	20-03-1989	NONE	
JP 63255653	A	21-10-1988	NONE	