



US 20080061984A1

(19) **United States**

(12) **Patent Application Publication**  
**Breed et al.**

(10) **Pub. No.: US 2008/0061984 A1**

(43) **Pub. Date: Mar. 13, 2008**

(54) **METHOD AND SYSTEM FOR OBTAINING INFORMATION ABOUT RFID-EQUIPPED OBJECTS**

(75) Inventors: **David S. Breed**, Miami Beach, FL (US); **Wendell C. Johnson**, Kaneohe, HI (US); **Wilbur E. DuVall**, Reeds Spring, MO (US)

Correspondence Address:

**BRIAN ROFFE, ESQ**  
**11 SUNRISE PLAZA, SUITE 303**  
**VALLEY STREAM, NY 11580-6111 (US)**

(73) Assignee: **AUTOMOTIVE TECHNOLOGIES INTERNATIONAL, INC.**, DENVILLE, NJ (US)

(21) Appl. No.: **11/926,302**

(22) Filed: **Oct. 29, 2007**

Said application No. 11/755,199 is a continuation-in-part of application No. 11/379,078, filed on Apr. 18, 2006, now abandoned, which is a continuation-in-part of application No. 11/220,139, filed on Sep. 6, 2005, now Pat. No. 7,103,460.

Said application No. 11/755,199 is a continuation-in-part of application No. 11/381,609, filed on May 4, 2006, which is a continuation-in-part of application No. 11/220,139, filed on Sep. 6, 2005, now Pat. No. 7,103,460.

Said application No. 11/755,199 is a continuation-in-part of application No. 11/382,091, filed on May 8, 2006, which is a continuation-in-part of application No. 11/220,139, filed on Sep. 6, 2005, now Pat. No. 7,103,460.

Said application No. 11/755,199 is a continuation-in-part of application No. 11/422,240, filed on Jun. 5, 2006, which is a continuation-in-part of application No. 11/220,139, filed on Sep. 6, 2005, now Pat. No. 7,103,460.

(Continued)

**Related U.S. Application Data**

(63) Continuation of application No. 11/755,199, filed on May 30, 2007, which is a continuation-in-part of application No. 10/940,881, filed on Sep. 13, 2004, which is a continuation-in-part of application No. 10/457,238, filed on Jun. 9, 2003, now Pat. No. 6,919,803.

Said application No. 11/755,199 is a continuation-in-part of application No. 11/082,739, filed on Mar. 17, 2005, which is a continuation-in-part of application No. 10/701,361, filed on Nov. 4, 2003, now Pat. No. 6,988,026, and which is a continuation-in-part of application No. 10/079,065, filed on Feb. 19, 2002, now Pat. No. 6,662,642.

Said application No. 11/755,199 is a continuation-in-part of application No. 11/278,188, filed on Mar. 31, 2006, now Pat. No. 7,313,467, which is a continuation of application No. 11/220,139, filed on Sep. 6, 2005, now Pat. No. 7,103,460, which is a continuation-in-part of application No. 11/120,065, filed on May 2, 2005, now abandoned.

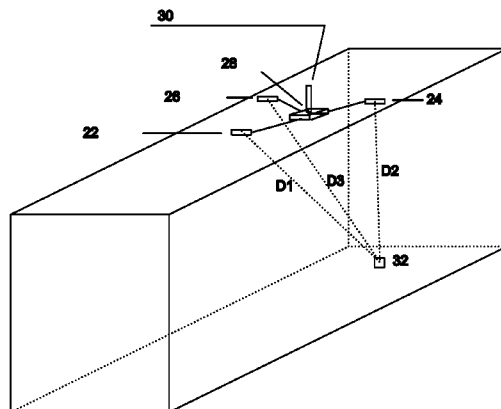
**Publication Classification**

(51) **Int. Cl.**  
**G08B 13/14** (2006.01)

(52) **U.S. Cl.** ..... **340/572.7**

(57) **ABSTRACT**

Method and arrangement for obtaining information about a radio-frequency identification (RFID) device or an object on which the RFID device is mounted when the RFID device is in a space defined by a frame includes arranging a plurality of antennas on the frame to enable transmission of signals into the space and reception of signals from the space, controlling transmission of signals by the antennas by means of an interrogator, and directing radio frequency signals from at least one of the antennas into the space to cause a RFID device in the space to return a signal if it receives any signal from any of the antennas. The return signals from the RFID device are received, e.g., by the interrogator or an associated receiver, and information about the RFID device or object to which the RFID device is attached is derived based on the return signals.



**Related U.S. Application Data**

Said application No. 11/755,199 is a continuation-in-part of application No. 11/428,498, filed on Jul. 3, 2006, which is a continuation-in-part of application No. 11/220,139, filed on Sep. 6, 2005, now Pat. No. 7,103,460.

Said application No. 11/755,199 is a continuation-in-part of application No. 11/457,231, filed on Jul. 13, 2006, which is a continuation-in-part of application No. 11/220,139, filed on Sep. 6, 2005, now Pat. No. 7,103,460.

Said application No. 11/755,199 is a continuation-in-part of application No. 11/461,473, filed on Aug. 1, 2006, which is a continuation-in-part of application No. 11/220,139, filed on Sep. 6, 2005, now Pat. No. 7,103,460.

Said application No. 11/755,199 is a continuation-in-part of application No. 11/470,061, filed on Sep. 5, 2006, which is a continuation-in-part of application No. 11/220,139, filed on Sep. 6, 2005, now Pat. No. 7,103,460.

Said application No. 10/940,881 is a continuation-in-part of application No. 10/931,288, filed on Aug. 31, 2004, now Pat. No. 7,164,117.

Said application No. 11/755,199 is a continuation-in-part of application No. 11/554,342, filed on Oct. 30, 2006, and which is a continuation-in-part of application No. 11/565,020, filed on Nov. 30, 2006, which is a continuation-in-part of application No. 10/931,288, filed on Aug. 31, 2004, now Pat. No. 7,164,117.

Said application No. 11/755,199 is a continuation-in-part of application No. 11/620,800, filed on Jan. 8, 2007, and which is a continuation-in-part of application No. 11/278,979, filed on Apr. 7, 2006, and which is a continuation-in-part of application No. 11/380,574, filed on Apr. 27, 2006, and which is a continuation-in-part of application No. 11/420,497, filed on May 26, 2006, and which is a continuation-in-part of application No. 11/421,500, filed on Jun. 1, 2006, which is a continuation-in-part of application No. 11/220,139, filed on Sep. 6, 2005, now Pat. No. 7,103,460.

Said application No. 11/428,498 is a continuation-in-part of application No. 10/931,288, filed on Aug. 31, 2004, now Pat. No. 7,164,117.

Said application No. 11/457,231 is a continuation-in-part of application No. 10/931,288, filed on Aug. 31, 2004, now Pat. No. 7,164,117.

Said application No. 11/755,199 is a continuation-in-part of application No. 11/459,700, filed on Jul. 25, 2006, which is a continuation-in-part of application No. 11/220,139, filed on Sep. 6, 2005, now Pat. No. 7,103,460.

Said application No. 11/461,473 is a continuation-in-part of application No. 10/931,288, filed on Aug. 31, 2004, now Pat. No. 7,164,117.

Said application No. 11/755,199 is a continuation-in-part of application No. 11/464,288, filed on Aug. 14, 2006, which is a continuation-in-part of application No. 10/931,288, filed on Aug. 31, 2004, now Pat. No. 7,164,117.

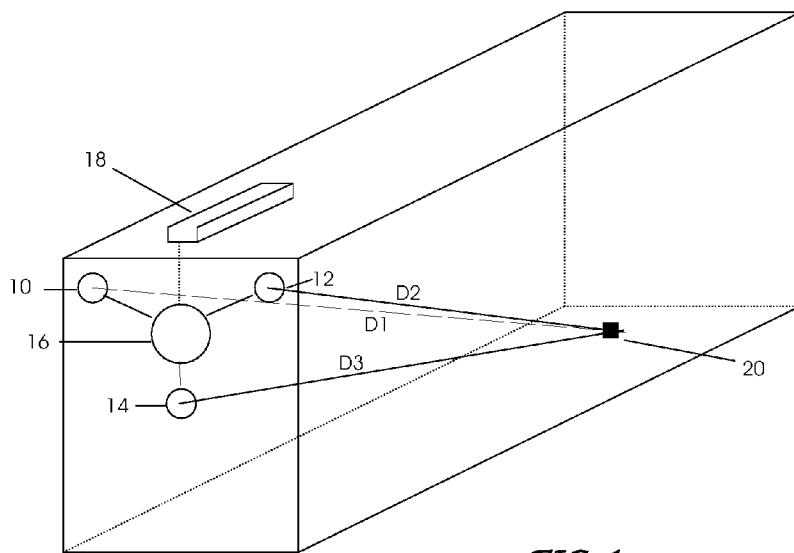
Said application No. 11/755,199 is a continuation-in-part of application No. 11/558,314, filed on Nov. 9, 2006, which is a continuation-in-part of application No. 10/931,288, filed on Aug. 31, 2004, now Pat. No. 7,164,117.

Said application No. 11/755,199 is a continuation-in-part of application No. 11/619,838, filed on Jan. 4, 2007, which is a continuation-in-part of application No. 10/931,288, filed on Aug. 31, 2004, now Pat. No. 7,164,117.

Said application No. 11/755,199 is a continuation-in-part of application No. 11/677,858, filed on Feb. 22, 2007, and which is a continuation-in-part of application No. 11/681,834, filed on Mar. 5, 2007.

Continuation of application No. 11/755,199, filed on May 30, 2007.

- (60) Provisional application No. 60/387,792, filed on Jun. 11, 2002. Provisional application No. 60/423,613, filed on Nov. 4, 2002. Provisional application No. 60/461,648, filed on Apr. 8, 2003. Provisional application No. 60/592,838, filed on Jul. 30, 2004. Provisional application No. 60/304,013, filed on Jul. 9, 2001. Provisional application No. 60/269,415, filed on Feb. 16, 2001. Provisional application No. 60/291,511, filed on May 16, 2001.



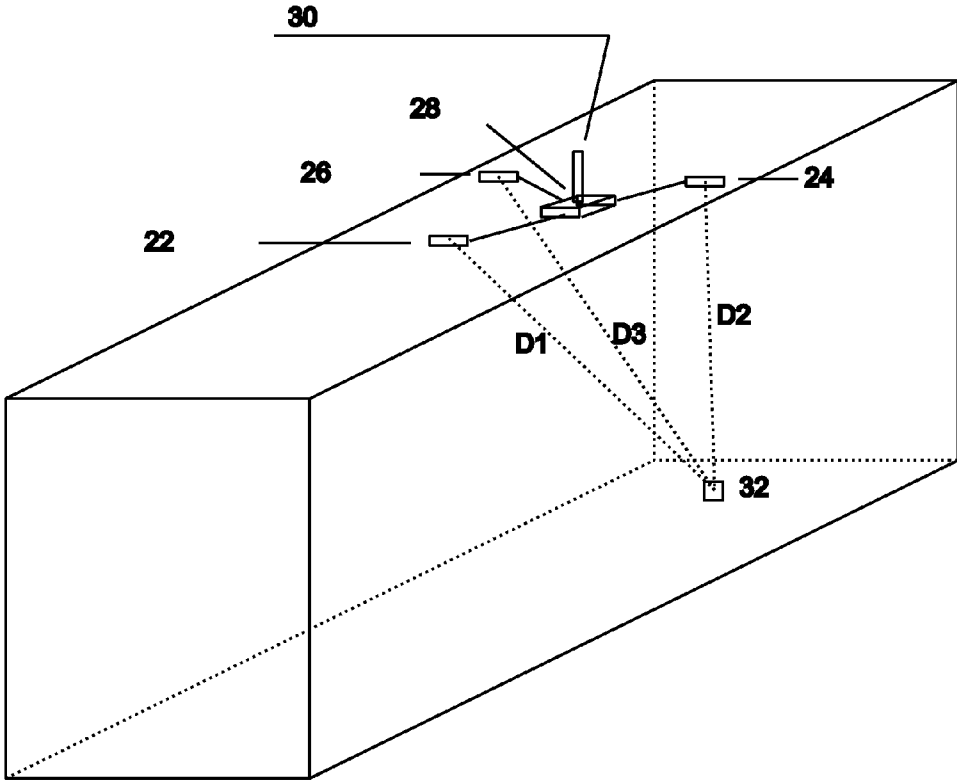


FIG. 2

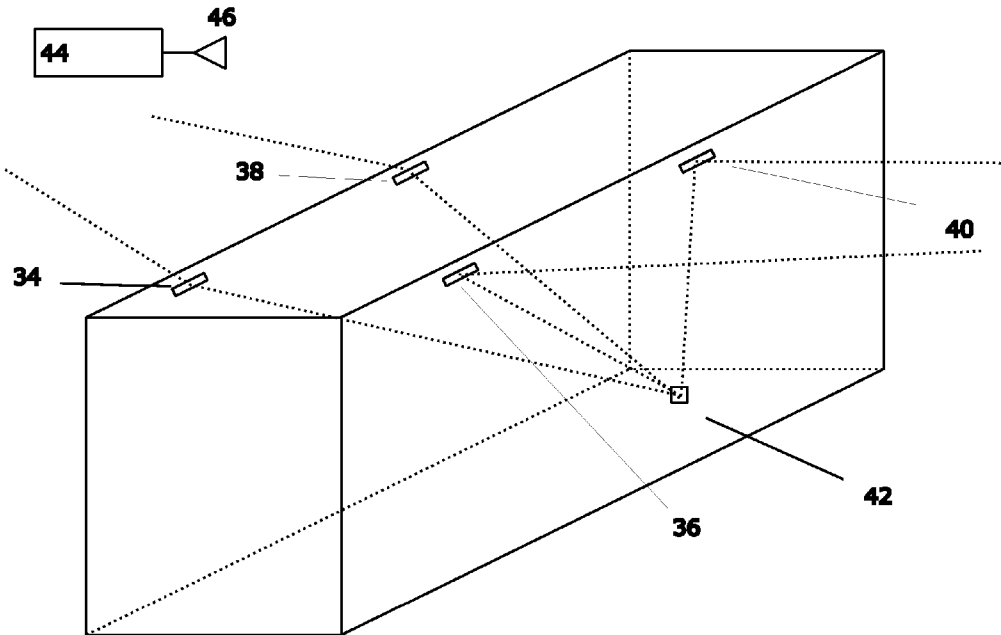


FIG. 3

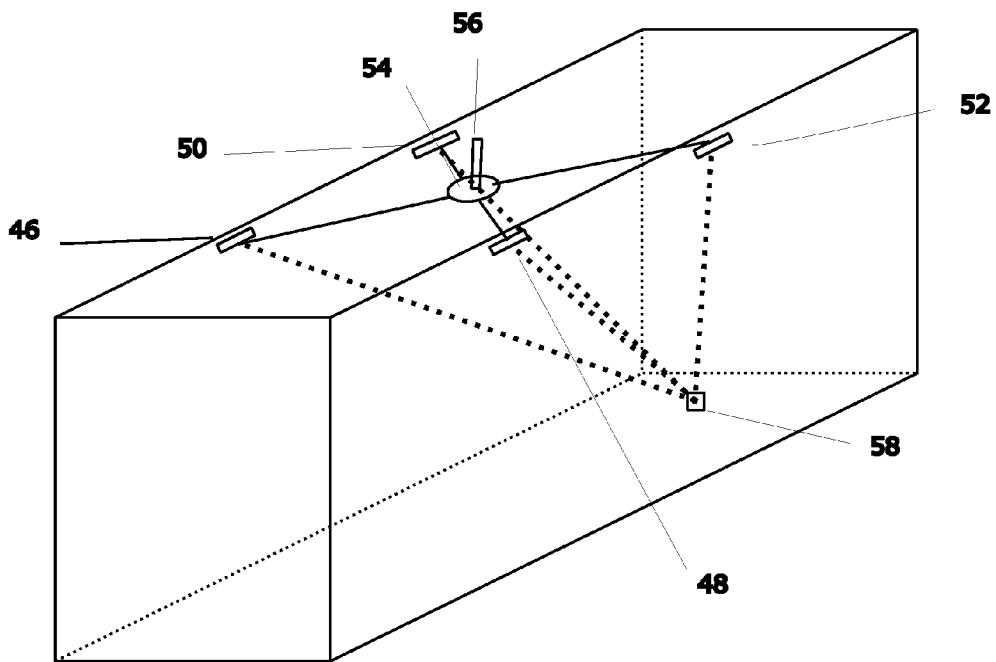
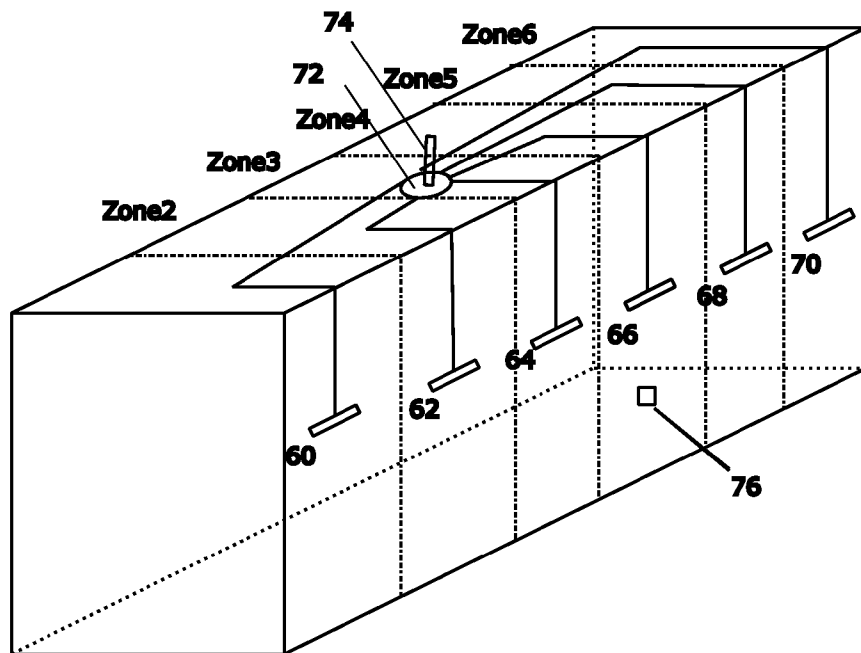


FIG. 4



*FIG. 5*

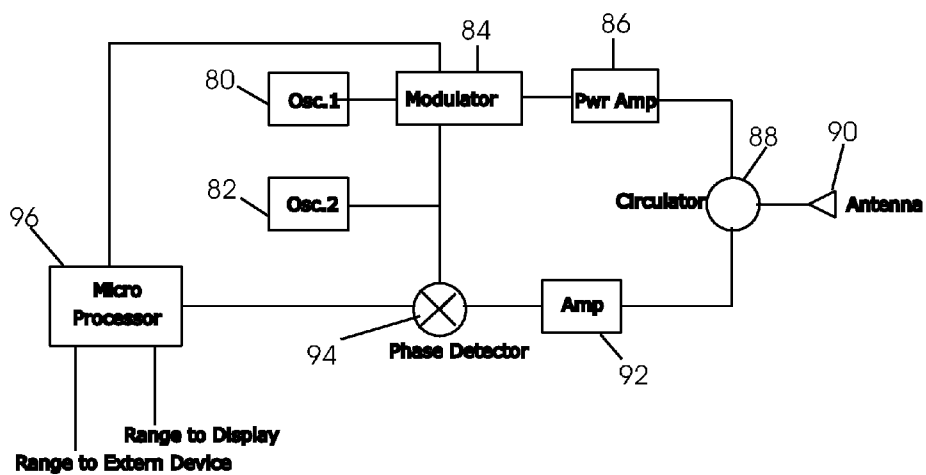


FIG. 6

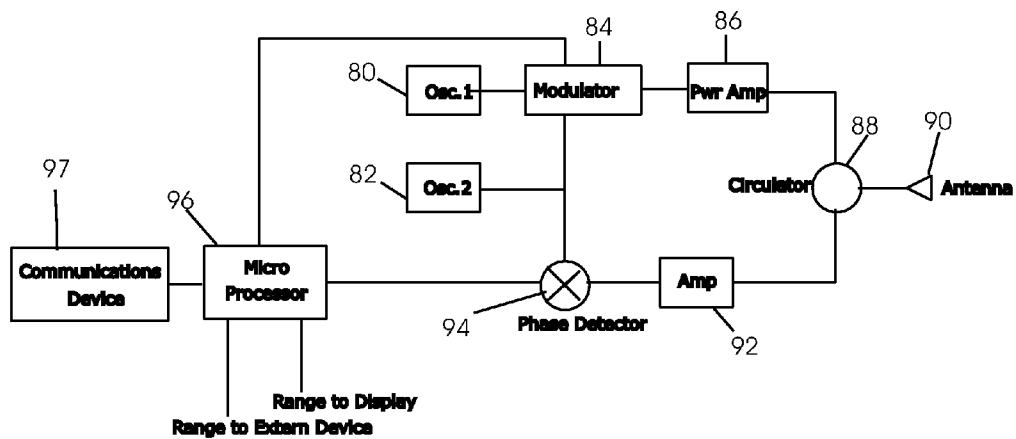


FIG. 7



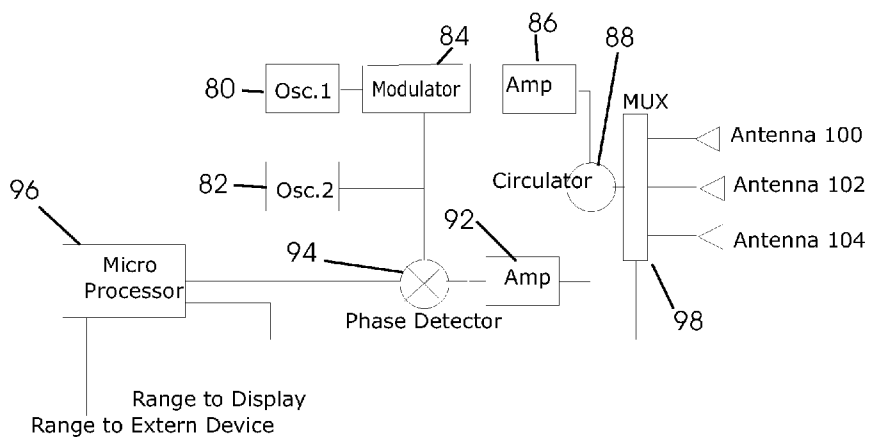


FIG. 8

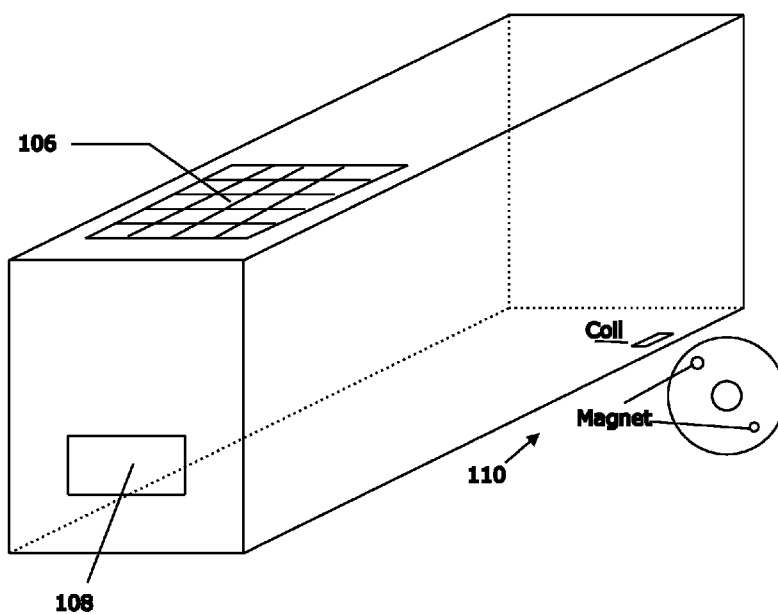
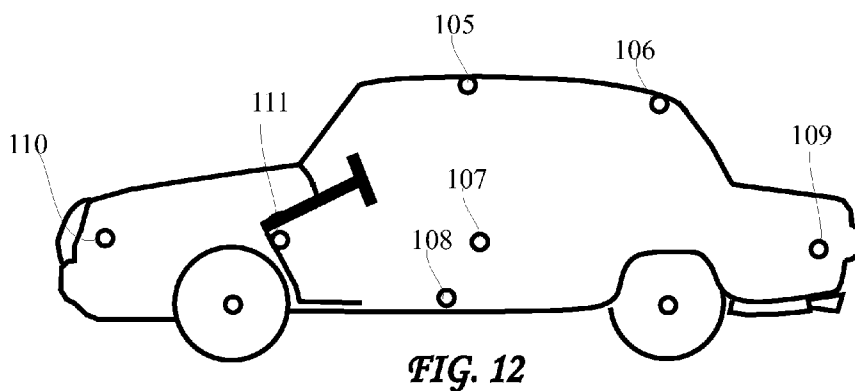
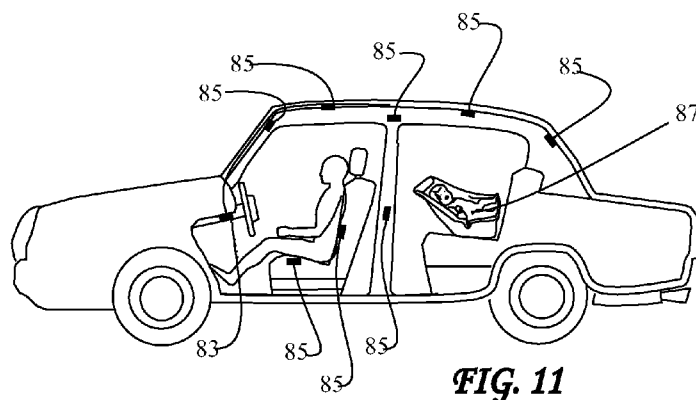
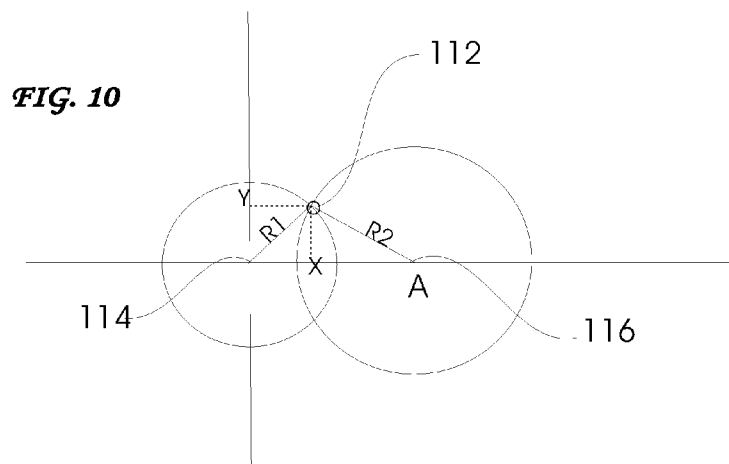
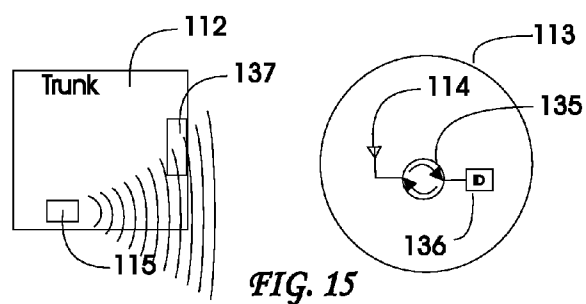
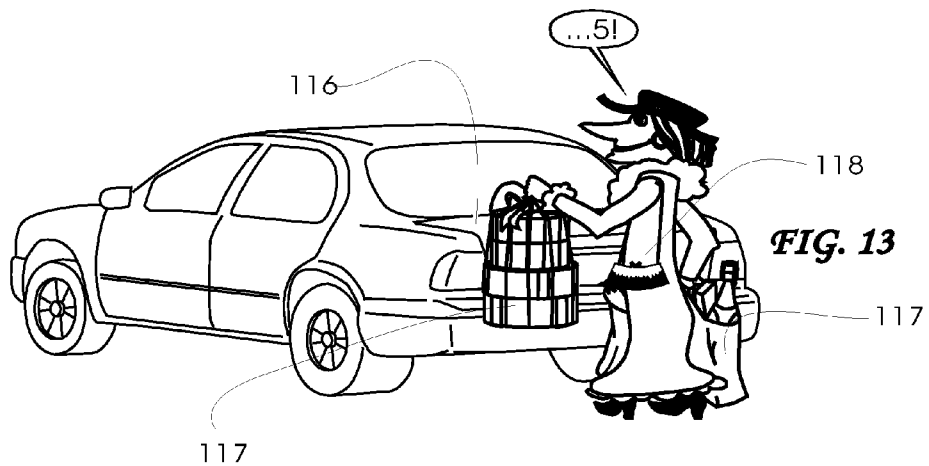
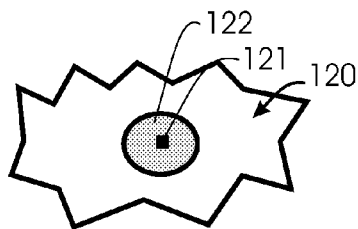


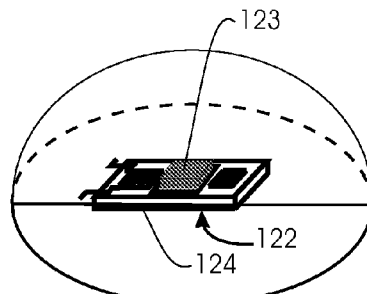
FIG. 9



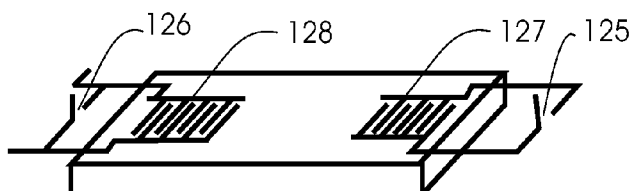




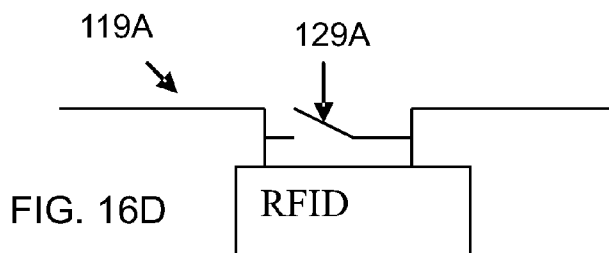
**FIG. 16A**



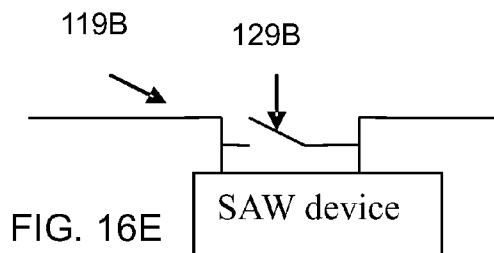
**FIG. 16B**



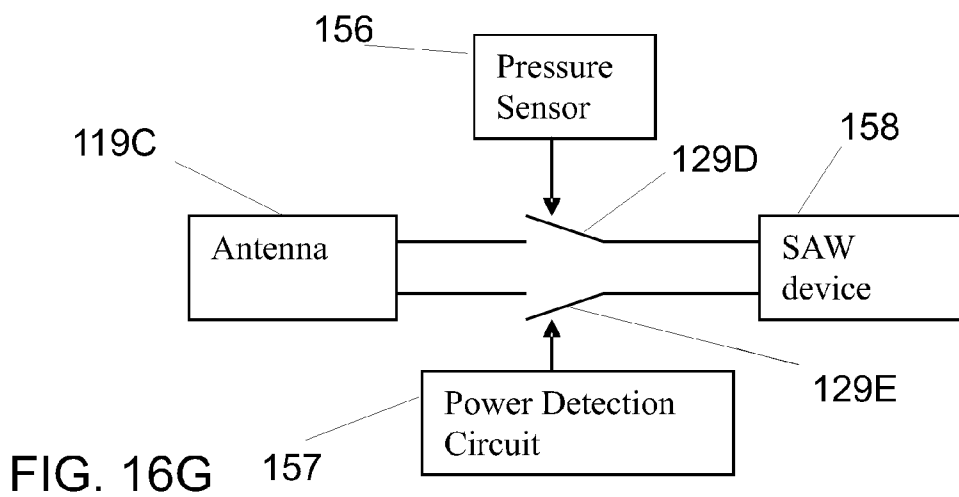
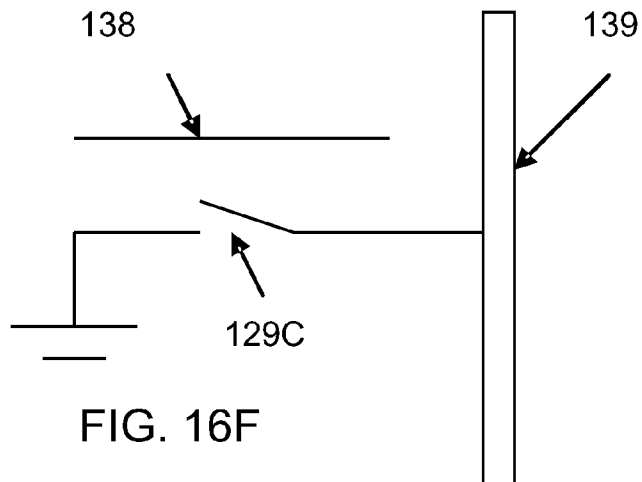
**FIG. 16C**



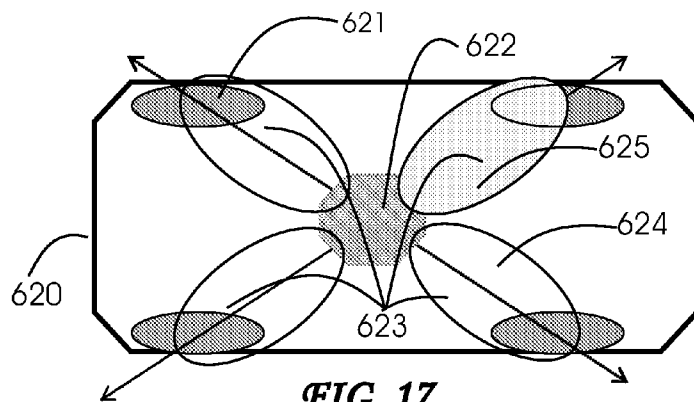
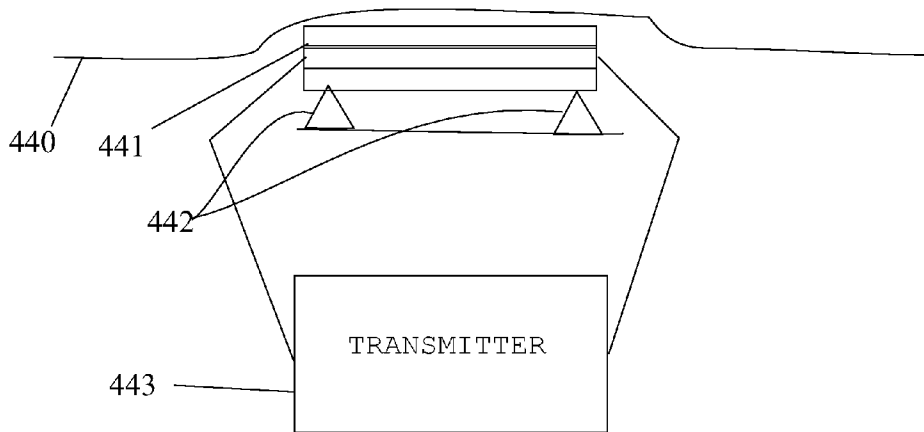
**FIG. 16D**



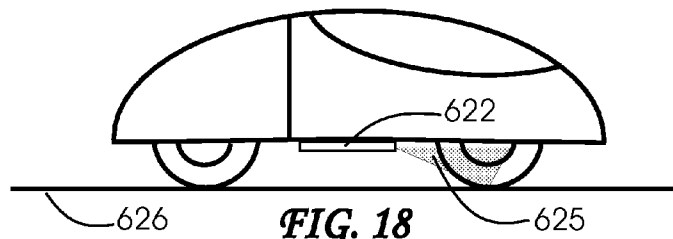
**FIG. 16E**



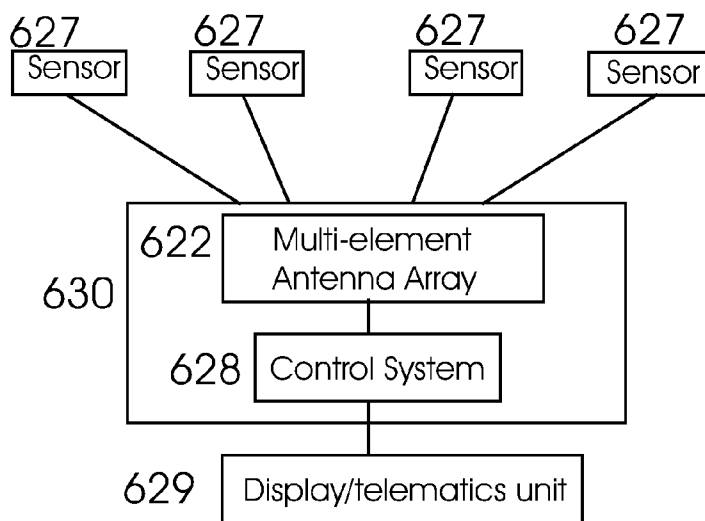
**FIG. 16H**



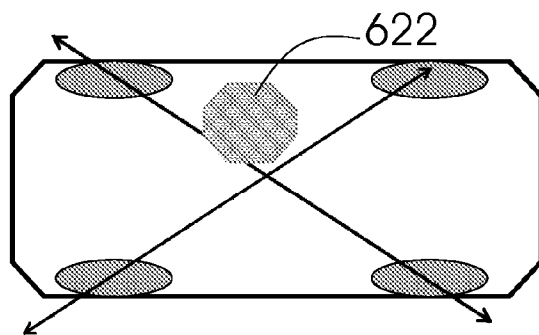
**FIG. 17**



**FIG. 18**



**FIG. 19**



**FIG. 20**

**METHOD AND SYSTEM FOR OBTAINING INFORMATION ABOUT RFID-EQUIPPED OBJECTS**

**CROSS REFERENCE TO RELATED APPLICATIONS**

[0001] This application is a continuation of U.S. patent application Ser. No. 11/755,199 filed May 30, 2007, which is:

[0002] 1. a continuation-in-part (CIP) of U.S. patent application Ser. No. 10/940,881 filed Sep. 13, 2004 which is:

[0003] A. a CIP of U.S. patent application Ser. No. 10/457,238 filed Jun. 9, 2003, now U.S. Pat. No. 6,919,803 which claims priority under 35 U.S.C. §119(e) of U.S. provisional patent application Ser. No. 60/387,792 filed Jun. 11, 2002, now expired;

[0004] B. a CIP of U.S. patent application Ser. No. 10/931,288 filed Aug. 31, 2004, now U.S. Pat. No. 7,164,117;

[0005] 2. a CIP of U.S. patent application Ser. No. 11/082,739 filed Mar. 17, 2005, which is a continuation of U.S. patent application Ser. No. 10/701,361 filed Nov. 4, 2003, now U.S. Pat. No. 6,988,026, which claims priority under 35 U.S.C. §119(e) of U.S. provisional patent application Ser. No. 60/423,613 filed Nov. 4, 2002, now expired, and U.S. provisional patent application Ser. No. 60/461,648 filed Apr. 8, 2003, now expired, and is a CIP of U.S. patent application Ser. No. 10/079,065 filed Feb. 19, 2002, now U.S. Pat. No. 6,662,642, which claims priority under 35 U.S.C. § 119(e) of U.S. provisional patent application Ser. No. 60/269,415 filed Feb. 16, 2001, now expired, U.S. provisional patent application Ser. No. 60/291,511 filed May 16, 2001, now expired, and U.S. provisional patent application Ser. No. 60/304,013 filed Jul. 9, 2001, now expired;

[0006] 3. a CIP of U.S. patent application Ser. No. 11/278,188 filed Mar. 31, 2006 which is a continuation of U.S. patent application Ser. No. 11/220,139 filed Sep. 6, 2005, now U.S. Pat. No. 7,103,460, which is a CIP of U.S. patent application Ser. No. 11/120,065 filed May 2, 2005, now abandoned, which claims priority under 35 U.S.C. § 119(e) of U.S. provisional patent application Ser. No. 60/592,838 filed Jul. 30, 2004, now expired;

[0007] 4. a CIP of U.S. patent application Ser. No. 11/278,979 filed Apr. 7, 2006;

[0008] 5. a CIP of U.S. patent application Ser. No. 11/379,078 filed Apr. 18, 2006 which is a CIP of U.S. patent application Ser. No. 11/220,139 filed Sep. 6, 2005, the history of which is set forth above;

[0009] 6. a CIP of U.S. patent application Ser. No. 11/380,574 filed Apr. 27, 2006;

[0010] 7. a CIP of U.S. patent application Ser. No. 11/381,609 filed May 4, 2006 which is a CIP of U.S. patent application Ser. No. 11/220,139 filed Sep. 6, 2005, the history of which is set forth above;

[0011] 8. a CIP of U.S. patent application Ser. No. 11/382,091 filed May 8, 2006 which is a CIP of U.S. patent application Ser. No. 11/220,139 filed Sep. 6, 2005, U.S. Pat. No. 7,103,460, the history of which is set forth above;

[0012] 9. a CIP of U.S. patent application Ser. No. 11/420,497 filed May 25, 2006;

[0013] 10. a CIP of U.S. patent application Ser. No. 11/421,500 filed Jun. 1, 2006 which is a CIP of U.S. patent application Ser. No. 11/220,139 filed Sep. 6, 2005, the history of which is set forth above;

[0014] 11. a CIP of U.S. patent application Ser. No. 11/422,240 filed Jun. 5, 2006 which is a CIP of U.S. patent application Ser. No. 11/220,139 filed Sep. 6, 2005, the history of which is set forth above;

[0015] 12. a CIP of U.S. patent application Ser. No. 11/428,498 filed Jul. 3, 2006 which is:

[0016] A. a CIP of U.S. patent application Ser. No. 10/931,288 filed Aug. 31, 2004, now U.S. Pat. No. 7,164,117, and

[0017] B. a CIP of U.S. patent application Ser. No. 11/220,139 filed Sep. 6, 2005, the history of which is set forth above;

[0018] 13. a CIP of U.S. patent application Ser. No. 11/457,231 filed Jul. 13, 2006 which is:

[0019] A. a CIP of U.S. patent application Ser. No. 10/931,288 filed Aug. 31, 2004, now U.S. Pat. No. 7,164,117, and

[0020] B. a CIP of U.S. patent application Ser. No. 11/220,139 filed Sep. 6, 2005, the history of which is set forth above;

[0021] 14. a CIP of U.S. patent application Ser. No. 11/459,700 filed Jul. 25, 2006 which is a CIP of U.S. patent application Ser. No. 11/220,139 filed Sep. 6, 2005, the history of which is set forth above;

[0022] 15. a CIP of U.S. patent application Ser. No. 11/461,473 filed Aug. 1, 2006 which is:

[0023] A. a CIP of U.S. patent application Ser. No. 10/931,288 filed Aug. 31, 2004, now U.S. Pat. No. 7,164,117, and

[0024] B. a CIP of U.S. patent application Ser. No. 11/220,139 filed Sep. 6, 2005, the history of which is set forth above;

[0025] 16. a CIP of U.S. patent application Ser. No. 11/464,288 filed Aug. 14, 2006 which is a CIP of U.S. patent application Ser. No. 10/931,288 filed Aug. 31, 2004, now U.S. Pat. No. 7,164,117;

[0026] 17. a CIP of U.S. patent application Ser. No. 11/470,061 filed Sep. 5, 2006 which is a CIP of U.S. patent application Ser. No. 11/220,139 filed Sep. 6, 2005, the history of which is set forth above;

[0027] 18. a CIP of U.S. patent application Ser. No. 11/554,342 filed Oct. 30, 2006;

[0028] 19. a CIP of U.S. patent application Ser. No. 11/558,314 filed Nov. 9, 2006 which is a CIP of U.S. patent application Ser. No. 10/931,288 filed Aug. 31, 2004, now U.S. Pat. No. 7,164,117;

[0029] 20. a CIP of U.S. patent application Ser. No. 11/565,020 filed Nov. 30, 2006 which is a CIP of U.S. patent application Ser. No. 10/931,288 filed Aug. 31, 2004, now U.S. Pat. No. 7,164,117;



[0030] 21. a CIP of U.S. patent application Ser. No. 11/619,838 filed Jan. 4, 2007 which is a CIP of U.S. patent application Ser. No. 10/931,288 filed Aug. 31, 2004, now U.S. Pat. No. 7,164,117;

[0031] 22. a CIP of U.S. patent application Ser. No. 11/620,800 filed Jan. 8, 2007;

[0032] 23. a CIP of U.S. patent application Ser. No. 11/677,858 filed Feb. 22, 2007; and

[0033] 24. a CIP of U.S. patent application Ser. No. 11/681,834 filed Jan. 8, 2007.

[0034] All of the foregoing patent application and all references, patents and patent applications that are referred to below are incorporated by reference in their entirety as if they had each been set forth herein in full.

#### FIELD OF THE INVENTION

[0035] The present invention relates generally to methods and systems for obtaining information about tagged objects, and more particularly to methods and systems for obtaining the location of, determining motion of and identifying objects within an asset using tags.

#### BACKGROUND OF THE INVENTION

[0036] Background of the invention is found in U.S. Pat. Nos. 6,820,897 and 6,919,803, and U.S. patent application Ser. No. 11/025,501, and additional information about the invention and its applicability, usage, fabrication, installation, synergy with other inventions and as well as U.S. patent application Ser. Nos. 11/502,039, 11/455,497, 10/940,881, 10/931,288, 10/895,121, 10/805,903, 10/733,957, 10/413,426, 10/365,129, 10/356,202, 10/227,780, 10/174,709, 10/151,615, 10/114,533, 10/058,706, 09/891,432, 09/838,920, 09/737,138, 09/563,556, 09/543,678, 09/437,535, 09/084,641, 09/047,704, 09/047,703, 08/640,068, 08/239, all of which are incorporated by reference herein.

[0037] Definitions in the Background of the Invention section of the '501 application are also generally, but not restrictively, applicable herein.

#### OBJECTS AND SUMMARY OF THE INVENTION

[0038] It is an object of the present invention to provide new and improved methods and systems for obtaining information about RFID devices and RFID-equipped objects in order to monitor such objects.

[0039] It is also an object of the present invention to provide assets equipped with a monitoring system for monitoring RFID-equipped objects.

[0040] In order to achieve one or both of these objects and possibly others, one embodiment of a method for obtaining information about an RFID device or an object on which the RFID device is mounted when the RFID device is in a space defined by a frame (of an asset) in accordance with the invention includes arranging a plurality of antennas on the frame to enable transmission of signals into the space and reception of signals from the space, controlling transmission of signals by the antennas by means of an interrogator, and directing radio frequency signals from at least one of the antennas into the space to cause a RFID device in the space

to return a signal if it receives any signal from any of the antennas. The return signals from the RFID device are received, e.g., by the interrogator or an associated receiver, and information about the RFID device or object to which the RFID device is attached is derived based on the return signals. This information may be position information, motion information, identification information, any other information than can be conveyed using RFID technology and combinations thereof.

[0041] In one embodiment, three antennas are provided on a common side of the space. For example, if the frame is a cargo container having a pair of opposed side walls, a pair of opposed front and rear walls, a roof and a floor, the antennas may be arranged on the roof or one of the walls of the frame, such as the front wall which is opposite the rear wall which is pivoted to open the container. The antennas may be arranged in a geometric configuration, such as a triangular configuration when three antennas are provided with the interrogator being arranged within the triangle defined by the antennas. Also, when three antennas are used, information about the RFID device or object to which the RFID device is attached may be location information which is obtained based on measurements of a distance between each of the antennas and the device, i.e., using triangulation.

[0042] In one embodiment, a communications device is also arranged on the frame and coupled to the interrogator. The information about the device can thus be transmitted to one or more remote sites using the communications device, these remote sites being those interested in the information about the objects in the frame of the asset being monitored.

[0043] In one embodiment, the frame is interposed between the interrogator and the space being monitored, and one or more RF windows are arranged on the frame to enable passage of signals between the interrogator and the space. The RF windows may be strategically placed relative to the antennas to optimize the passage of the signals therethrough.

[0044] The interrogator may be attached to the frame or separate and apart therefrom. In the latter case, the antennas may be coupled to an antenna multiplexer which in turn is coupled to an external antenna extending outside of the frame and which communicates with the interrogator. Transmission and reception of signals by the antennas is controlled via the multiplexer. Optionally, each antenna may be associated with a defined portion of the space, so that the location of the RFID device can be determined by analyzing strength of return signals to all of the antennas to determine which antenna provides the largest return signal. The RFID device is considered to be located in that portion of the space associated with the antenna which provides the largest return signal. For example, the space may be partitioned into a plurality of discrete longitudinal portions (extending from the front to the rear of the interior space defined by the frame), each antenna being associated with only a single one of the portions.

[0045] To provide power to the interrogator and antennas, an electricity-generating system may be arranged on the frame and coupled to the interrogator and antennas to provide electricity for operation thereof. Various electricity-generating systems are envisioned.

[0046] In one embodiment, the interrogator and the RFID device are provided with a clock, the RFID device is

arranged to synchronize its clock upon reception of any signal from any of the antennas relative to the interrogator's clock and the RFID device is also arranged to return the signal if it receives any signal from any of the antennas only after synchronization of its clock to the interrogator's clock. The interrogator can thus predict a transmit time at which the RFID device will return a signal after reception of a signal from one of the antennas whose transmission is controlled by the interrogator. In this manner, it is possible to derive information about the RFID device or the object to which the RFID device by analyzing an arrival time of the return signal from the RFID device and the predicted transmit time which will provide, for example, a measurement of a distance between the RFID device and the antenna to be determined. The RFID device may be arranged to return the signal at a specific time relative to the reception of the signal from the antenna, at a specific time relative to a time when the signal from the antenna was sent or at a predesignated time.

[0047] In one embodiment, radio frequency signals are directed from a plurality of antennas into the space, and the RFID device is arranged to provide information in the return signal indicative of a phase or relative time of reception of signals from multiple antennas.

[0048] An asset with an integral system for obtaining information about an RFID device or an object on which the RFID device is mounted when the RFID device or object is in or in connection with the asset in accordance with the invention includes a frame defining an interior space of the asset, a plurality of antennas, such as three, arranged on the frame and enabling transmission of radio frequency signals into the space and reception of signals from the space, and an interrogator coupled to the antennas and arranged to control transmission of signals by the antennas. When a RFID device in the space receives a transmitted signal, it generates a return signal, the antennas being arranged to receive the return signals generated by any RFID devices in the space. A processor is coupled to the antennas and the interrogator and receives and analyzes the return signals received by the antennas to derive information about the RFID device or object on which the RFID device is mounted based on the return signals. This information may be position information, motion information, identification information, any other information than can be conveyed using RFID technology and combinations thereof.

[0049] The features and variations of the method described above can be applied to the asset in accordance with the invention as well. The frame of the asset may be a frame of a truck, a frame of truck trailer, a frame of a shipping container, a frame of a boat, a frame of an airplane or a frame of another vehicle.

[0050] One embodiment of a monitoring system for monitoring objects in an asset in accordance with the invention includes a frame defining an interior space of the asset, a plurality of antennas arranged on the frame and enabling transmission of radio frequency signals into the space and reception of signals from the space, an RFID device arranged in connection with each object to be monitored, and an interrogator coupled to the antennas and arranged to control transmission of signals by the antennas. When one of the RFID devices present in the space receives a transmitted signal, it generates a return signal, the antennas being arranged to receive the return signals generated by any of the

RFID devices in the space. A processor is coupled to the antennas and the interrogator and receives and analyzes the return signals received by the antennas to derive information about the RFID device or object on which the RFID device is mounted based on the return signals. The features and variations of the method and asset described above can be applied to the monitoring system in accordance with the invention as well.

#### BRIEF DESCRIPTION OF THE DRAWINGS

[0051] The following drawings are illustrative of embodiments of the system developed or adapted using the teachings of at least one of the inventions disclosed herein and are not meant to limit the scope of the invention as encompassed by the claims.

[0052] FIG. 1 illustrates a first embodiment of a cargo space equipped with a system in accordance with the invention for obtaining information from a tagged object in the cargo space.

[0053] FIG. 2 illustrates a second embodiment of a cargo space equipped with a system in accordance with the invention for obtaining information from a tagged object in the cargo space.

[0054] FIG. 3 illustrates an embodiment of a cargo space with RF windows.

[0055] FIG. 4 illustrates an embodiment of a cargo space with an antenna multiplexer arrangement.

[0056] FIG. 5 illustrates an embodiment of a cargo space with multiple antennas which enable the position of a tag to be determined based on reception of signals by the antennas.

[0057] FIGS. 6 and 7 are block diagrams of an interrogator with a single antenna which may be used in the invention.

[0058] FIG. 8 is a block diagram of an interrogator with multiple antennas which may be used in the invention.

[0059] FIG. 9 illustrates systems for deriving or harvesting electrical power for use in the invention.

[0060] FIG. 10 illustrates a method of using triangulation to determine the location of a tag within a cargo space in accordance with the invention.

[0061] FIG. 11 is a cutaway view of a vehicle showing possible mounting locations for vehicle interior temperature, humidity, carbon dioxide, carbon monoxide, alcohol or other chemical or physical property measuring sensors.

[0062] FIG. 12 is a schematic of a vehicle with several accelerometers and/or gyroscopes at preferred locations in the vehicle.

[0063] FIG. 13 illustrates a driver with a timed RFID standing with groceries by a closed trunk.

[0064] FIG. 14 illustrates the driver with the timed RFID 5 seconds after the trunk has been opened.

[0065] FIG. 15 illustrates a trunk opening arrangement for a vehicle in accordance with the invention.

[0066] FIG. 16A is a view of a SAW switch sensor for mounting on or within a surface such as a vehicle armrest.

[0067] FIG. 16B is a perspective view of the device of FIG. 16A with the force-transmitting member rendered transparent.

[0068] FIG. 16C is a perspective view of an alternate SAW device for use in FIGS. 16A and 16B showing the use of one of two possible switches, one that activates the SAW and the other that suppresses the SAW.

[0069] FIG. 16D is a schematic of a RFID controlled by a switch.

[0070] FIG. 16E is a schematic of a SAW device controlled by a switch.

[0071] FIG. 16F is a schematic of a backscatter antenna which is controlled by a switch.

[0072] FIG. 16G is a schematic of circuit for a monitoring system in accordance with the invention which has two switches.

[0073] FIG. 16H illustrates one embodiment of a switch whereby activation of the switch provides the energy necessary to power an RFID.

[0074] FIG. 17 is a top view of a system for obtaining information about a vehicle or a component therein, specifically information about the tires, such as pressure and/or temperature thereof.

[0075] FIG. 18 is a side view of the vehicle shown in FIG. 17.

[0076] FIG. 19 is a schematic of the system shown in FIGS. 17 and 18.

[0077] FIG. 20 is a top view of an alternate system for obtaining information about the tires of a vehicle.

#### DETAILED DESCRIPTION OF THE INVENTION

[0078] Although many of the examples below relate to a cargo space in an asset, the invention is not limited to any particular space in any particular asset and is thus applicable to all types of assets including vehicles, shipping containers and truck trailers and to all spaces or compartments of a vehicle including, for example, the passenger compartment and the trunk of an automobile or truck.

[0079] Referring to the accompanying drawings, FIGS. 1-10 illustrate a method and system for identifying and locating an RFID-tagged article inside a cargo space defined by a frame. The RFID tags can be active, passive or a combination of both, or MIR transmitters, or devices providing backscatter. The system can employ multiple antennas inside a cargo space, truck trailer or other vehicle cargo space as illustrated in FIGS. 1-6. The system is preferably designed for a low power battery operation when the cargo space is not tethered to a power source. Some energy harvesting methods for powering the system are shown in FIG. 9. The system requires little power and has a low duty cycle when not connected to a power source thus the system will provide RFID tag identification for many years with internal battery power.

[0080] A passive RFID tag can operate at about 915 MHz (ISM band) complying with FCC rule 15, for example, or

other rules that may apply either in the US or other countries. The frequency can be any frequency permitted under these rules.

[0081] FIG. 1 illustrates an embodiment of a cargo space with three antennas 10, 12, 14 spaced in a triangular fashion and connected to an interrogator 16 internal to the cargo space with the antennas 10, 12, 14 shown in one possible configuration arranged on a common wall of the cargo space. The internal arrangement of the interrogator 16 to the cargo space means that the interrogator is arranged on one or more of the walls defining the cargo space, inside or within one or more of the walls defined the cargo space and/or within the space defined by the walls of the cargo space. Specifically, for the shipping container shown in FIG. 1 having a pair of opposed side walls, a pair of opposed front and rear walls, a roof and a floor, the antennas 10, 12, 14 are arranged in the front wall. This wall may be the fixed wall opposite the door of the shipping container. In other embodiments, the antennas 10, 12, 14 are arranged in the other walls of the container.

[0082] The interrogator 16 may be arranged within the triangle defined by the antennas 10, 12, 14, for example, at or about the approximate center of the triangle. In other embodiments with multiple antennas, the interrogator may be situated to be equidistant from all of them. Nevertheless, the location of the interrogator relative to the antennas is not critical to the practice of the invention and the interrogator may be placed anywhere on the asset defining the cargo space, or even separate and apart from the asset, as described below. The interrogator 16 may be connected to the antennas 10, 12, 14 using wires or wirelessly.

[0083] The interrogator 16 can be connected to a satellite or other communication unit 18 from the interior of the cargo space using a wire or wirelessly using an antenna. As shown, communication unit 18 is arranged on a roof of the asset. The satellite or other communication unit 18 can have an external antenna and can be used to send tag information to a remote site. The distances from each antenna 10, 12, 14 to an RFID device or tag 20 are shown as D1, D2 and D3. These distances can be measured by an interrogator 16 shown schematically in FIG. 8, or by a processor associated with or resident within the interrogator 16 or separate therefrom. The processor could also process the distances to derive other information about the RFID device 20 or an object in connection with which the RFID device 20 is mounted. For example, such a processor can also derive additional or alternative information about the RFID device 20, such as motion thereof or its identification if it is designed to generate a return signal with identification data.

[0084] There are known arrangements of or programming for interrogator 16, or the processor associated therewith, to measure or otherwise determine distances D1, D2 and D3 based on the return signals. However, in one particular embodiment, RFID devices 20 are used which have the capability of returning a signal at a precise time with this knowledge being used to determine the distance between the RFID device or object in connection therewith and the antennas 10, 12, 14. To achieve this, the interrogator 16 and RFID device 20 are each provided with a clock, and the RFID device 20 synchronizes its clock upon reception of any signal from any of the antennas 10, 12, 14 relative to the interrogator's clock returns a signal, if it receives any signal

from any of the antennas **10, 12, 14**, only after synchronization of its clock to the interrogator's clock. The interrogator **16**, or processor associated therewith, is arranged or programmed to predict a transmit time at which the RFID device **20** will return a signal after reception of a signal whose transmission is controlled by the interrogator **16**. The actual arrival time of the return signal from the RFID device **20** is analyzed relative to the predicted transmit time (the time the return signal was transmitted by the RFID device **20**), e.g., compared thereto, to enable a measurement of a distance between the RFID device **20** and the antennas **10, 12, 14** to be determined. Thus, in this embodiment, the RFID device **20** returns a signal at a specific time after receipt of an interrogation signal or pulse from one or more of the antennas **10, 12, 14**, at a specific time after the signal or pulse was sent by one or more of the antennas **10, 12, 14** or at an appointed or predesignated time. In the latter case, predesignation of times might entail creating a specific formula for determining the predesignated times.

[0085] In one embodiment when the interrogator **16** causes transmission of signals from multiple antennas **10, 12, 14**, the RFID **20** when receiving signals from one or more of these antennas **10, 12, 14** may be arranged or programmed to provide information in the return signal indicative of a phase or relative time of reception of signals from the multiple antennas. The processor associated with the interrogator **16** would analyze the return signals and, from the phase or time reception information, derive information about the RFID device **20** or object to which it is mounted, such as distance information or motion information.

[0086] FIG. 2 illustrates an embodiment of a cargo space with three antennas **22, 24, 26** spaced in a triangular fashion located on the roof, ceiling or top of the shipping container defining the cargo space and connected to an interrogator **28** internal to the cargo space. The interrogator **28** is connected to an external antenna **30** and can also be connected to a satellite or other communication unit as in FIG. 1. The distances from each antenna **22, 24, 26** to the RFID device or tag **32** are shown as D1, D2 and D3. The interrogator **28** may be arranged within the triangle defined by the antennas **22, 24, 26** or elsewhere. The variations described for the embodiment shown in FIG. 1 are equally applicable to this embodiment.

[0087] Mounting of the antennas **22, 24, 26**, or possibly any other type of electromagnetic energy transmitter, on the roof of the shipping container is advantageous in that it is very unlikely to interfere with the maximum use of the cargo space provided by the shipping container.

[0088] FIG. 3 illustrates an embodiment of a shipping container defining a cargo space with multiple RF windows **34, 36, 38, 40** in the frame of the container. The windows **34, 36, 38, 40** allow for the signal to and from one or more RFID devices or tags **42** in the cargo space to transmit and receive signals from an interrogator **44** such as shown schematically in FIG. 6 which can be located outside of the cargo space. This embodiment therefore enables an interrogator **44** to obtain signals via antenna **46** from an RFID device or tag **42** within a cargo space while the interrogator **44** is separate and apart from the cargo space. Such RF windows would be needed anytime the frame is interposed between the interrogator and its antenna, and the space defined by the frame.

It is thus conceivable that the interrogator and its antenna may even be arranged on the frame yet require one or more RF windows to enable signals from the antenna to pass into the space and return signals from any RFID devices in the space to pass out of the space to be received by the antenna.

[0089] The size, location and number of RF windows in an asset, such as the shipping container defining the cargo space shown in FIG. 3, can vary depending on, for example, the expected and possible locations of RFID devices or tags in the cargo space or other space defined by the asset, the dimensions of the cargo space or other space defined by the asset, and the expected relative position between the antenna of the interrogator and the RFID devices. It is possible that one or more RF windows be situated at the same location on a particular type of shipping container and that a scanning system being provided for use with such shipping containers which is designed to accept one or more shipping containers in a position in which the RF windows are automatically properly aligned with an antenna of an interrogator of the scanning system. This will simplify the scanning of the shipping containers.

[0090] FIG. 4 illustrates an embodiment of a cargo space with a multiple of internal antennas **46, 48, 50, 52** connected to an antenna multiplexer **54** (such as a PE4261 SP4T RF UltraCMOSTM Flip Chip Switch manufactured by Peregrine Semiconductor). As shown, antennas **46, 48, 50, 52** are all arranged at the top of the shipping container defining the cargo space.

[0091] The multiplexer **54** may be connected to an antenna **56** outside of the cargo space (an external antenna, yet one which is still mounted on or attached to the frame defining the cargo space) for communications with an external interrogator such as illustrated in FIG. 6. A transceiver may be connected between the multiplexer **54** and the external antenna **56** in order to increase the signal strength of the signals from the RFID device **58** which is internal to the shipping container defining the cargo space. The external antenna **56** is used to communicate with an interrogator and its antenna which is used to control the transmissions of signals by the antennas **46, 48, 50, 52** and process signals received by the antennas into information about the RFID device **58** or an object on or to which the RFID device is mounted to attached. A processor may be used for this purpose and may either be part of the interrogator or separate therefrom.

[0092] The RFID device location in the cargo space may be determined by measuring the distances from the RFID device **58** to each of the internal antennas **46, 48, 50, 52** by triangulation as illustrated in FIG. 10 and described below. Triangulation may be used in the same manner whenever there are at least three antennas which receive signals generated by the presence of an RFID device in a monitored cargo space.

[0093] FIG. 5 illustrates an embodiment of a cargo space with multiple internal antennas **60, 62, 64, 66, 68, 70** connected to an antenna multiplexer **72** (such as the PE4261). The multiplexer **72** may be connected to an external antenna **74** outside of the cargo space for communications with an external interrogator such as illustrated in FIG. 6. As in the embodiment of FIG. 4, a transceiver may be connected between the multiplexer **72** and the outside antenna **74** for increasing the signal strength of the signals

from the RFID device 76 or RFID devices which are within the cargo space. The RFID device location in the cargo space may be determined by measuring the signal strengths from the internal antennas 60, 62, 64, 66, 68, 70, whereby the antenna closest to the RFID device 76 will have the largest or strongest signal therefore the zone where the RFID device 76 is located in the cargo space may be determined.

[0094] When using multiple antennas on an asset and deriving the general location of area of the RFID device or RFID-device equipped object based on the signal strength, the antennas can be distributed or spaced apart along any single dimension of the asset, e.g., longitudinally for the shipping container as shown in FIG. 5. In this manner, the approximate longitudinal location of the RFID device or object equipped therewith could be determined. Of course, when two antennas provide signals having equal strength, it could be derived that the RFID device is situated exactly between the antenna locations.

[0095] In one embodiment, the antennas are arranged along a longitudinal center line of the cargo space, e.g., down the center of a shipping trailer or container.

[0096] FIG. 6 illustrates a block diagram of an interrogator with a single antenna which may be used in the embodiments herein. Information from this interrogator may be displayed locally or sent over a communications link, such as a satellite, cell phone, internet or equivalent link, to a remote location for processing, logging, re-transmission or for any other purpose.

[0097] The interrogator 78 includes a pair of oscillators 80, 82, a modulator 84 processing the output from oscillators 80, 82 and providing output to a power amplifier 86, a circulator 88 connected to the power amplifier 86 and providing a signal for transmission by the antenna 90 with a signal being received by antenna 90 being directed through the circulator 88 to an amplifier 92, and a phase detector 94 connected to the oscillator 82, modulator 84 and amplifier 92 and performing a phase comparison between the signals transmitted and received via antenna 90. A microprocessor 96 is coupled to the modulator 84 and phase detector 94 and analyzes the phase comparison to determine information about a RFID device which returns a signal to the antenna 90. This information may be distance or range information, which may be provided to an external device or a display. Additionally or alternatively, it may be identification information or motion information.

[0098] The information may be derived using the known speed of the waves and the time for travel of the waves, since the distance between the antenna and the RFID-device is equal to one-half the speed multiplied by the total travel time. The frequency can be calculated from the determined time and the range of the phase detector is radians.

[0099] FIG. 7 illustrates a block diagram of an interrogator with a single antenna similar to that shown in FIG. 6. Information from this interrogator may be displayed locally or sent over a communications link via a communications device 97 to a remote location as above. This embodiment of an interrogator shows a method for measuring the distance from the interrogator antenna to the antenna of an RFID device. The modulation used may be either amplitude or frequency; the phase detector may be of the phase/frequency type. An exemplifying calculations for amplitude

modulation would involve determining the time for travel of the waves, which is equal to twice the distance between the antenna and the RFID-device (having a set maximum of 5 meters) divided by the speed of light. The frequency can be calculated from the determined time and the range of the phase detector is radians.

[0100] FIG. 8 illustrates a block diagram of an interrogator with multiple antennas which may be used in embodiments herein. The block diagram is similar to that shown in FIG. 6 and the same reference numerals designate the same elements. However, in this embodiment, individual antennas are selected by a MUX 98 (which may be one designated in the field as a PE4261). The MUX 98 controls the transmission and reception of signals via antennas 100, 102, 104. Any number of antennas may be provided, and using the PE4261, up to six antennas may be used. Control of the MUX 98 may be achieved using the microprocessor 96 which is coupled thereto.

[0101] Information from this interrogator may be displayed locally or sent over a communications link to a remote location as described above. This embodiment of an interrogator shows a method for measuring the distance from the selected interrogator antenna to a tag antenna. The modulation may be either amplitude or frequency; the phase detector may be of the phase/frequency type. Example calculations are shown for amplitude modulation. By using the distances from the antennas 100, 102, 104 to a tag, the location of the tag can be calculated by triangulation as shown in FIG. 10 and described below.

[0102] FIG. 9 illustrates three exemplary methods for deriving or harvesting electrical power for the operation of interrogators, multiplexers and/or transceivers/transmitters, as well as any other electricity consuming devices on the cargo container needed for the operation or purpose of gathering information about a tagged object in the cargo space, whether situated within or in the cargo space or within, in or on the structure defining the cargo space. These include solar panels 106 (shown in the top of the cargo container), a vibration to voltage generator 108 (shown on a side of the container) and a magnetic field variation device 110 which generates electrical power based on variations in a magnetic field caused by movement of the container.

[0103] FIG. 10 illustrates a method of using triangulation to determine the location of a typical tag 112 within a cargo space, which may be used in embodiments described herein. The exemplary tag location determination by triangulation is shown for two dimensions in the x, y plane but may be readily extended to a three-dimensional x, y, z space.

[0104] Let:

[0105] R1=The measured range from Antenna 114 to the tag 112.

[0106] R2=The measured range from Antenna 116(a,0) to the tag 112.

[0107] a=known distance between antennas

$$R1^2 = x^2 + y^2$$
$$y^2 = R1^2 - x^2$$
Eq(1)

$$R2^2 = (x+a)^2 + y^2$$
Eq(2)

substituting:

$$R2^2 := (x+a)^2 + R1^2 - x^2$$

$$R2^2 - R1^2 := x^2 + 2ax + a^2 - x^2$$

$$2ax := R2^2 - R1^2 - a^2$$

R1 and R2 are measured values and a is known by the distance between the antennas **114**, **116** therefore; x can be computed. Once x is computed y can be found by substituting x into equation 1.

$$x := \frac{(R2^2 - R1^2 - a^2)}{2 \cdot a}$$

[**0108**] The location of the tag **112** in three dimensions can now be easily found by those skilled in the art.

[**0109**] The above analysis has been based on the time of arrival of a signal from a tag at the various antennas. Other methods based on the angle of arrival can permit vectors to be drawn that pass through the tag location and then based on the calculation of the intersection of these vectors, the location of the tag can be found. Information about this technique is disclosed, for example, in Z. Wen, L. Li, and P. Wei "Fast Direction Using Modified Pseudocovariance Matrix", IEEE Transactions on Antennas and Propagation, Vol 54, No. 12, December 2006, and articles referenced therein.

[**0110**] An alternate approach would be for the antennas to send short pulses which all of the tags would hear and record the times of arrival. This recording would then be sent back to the interrogator from which the interrogator circuitry could determine the location of a tag based on the pattern of signals that the tag heard. Each antenna could append an ID so that the tag could record the tag signal correspondence. These techniques can be based on relative times or on absolute time. The latter could be determined by a variety of methods including syncing the clock on each tag with the interrogator clock.

[**0111**] Another method of determining the location of a tag is to enable the tag to either receive or transmit ultrasound. In the latter case, the tag would emit an ultrasonic pulse when it receives an RF pulse and listeners distributed around the cargo space would receive each ultrasonic pulse at a different time and thereby know, or enable a determination of, the distance to the tag. If there are three listeners, then the tag location is known based on the known location of the listeners.

[**0112**] The methods and systems described above for interacting with RFID devices or tags are equally applicable for other types of tags or responsive devices including but not limited to various SAW devices, resonators and reflectors (e.g., dihedral reflectors), such as disclosed in the applications listed above. The information obtained by the methods and system in accordance with the invention which interact with these devices may be identification information and/or positional information. In the latter case, when tags are installed onto fixed components of assets, such as a seat or door in a vehicle, their presence, positions and/or orientations can be determined and used to control other systems, such as vehicular systems having output which varying as a function of the presence, position and/or orientation of the

components (which may correlate to the presence, position and/or orientation of human occupants of the vehicles).

[**0113**] The methods and system in accordance with the invention can be used to interrogate multiple RFID devices or similar tags. In this case, the identification, location and/or motion of multiple RFID devices or objects associated therewith can be determined.

[**0114**] In a preferred embodiment, the asset is a vehicle and one or more components are equipped with RFID devices. The interrogator controls transmission of RF signals from the antennas to cause these RFID devices to generate return signals. Analysis of these return signals by a processor associated with the interrogator can be used to derive information about the components. In this regard, reference is made to the disclosure of U.S. Pat. No. 6,820,897 which is directed to, among other things, use of resonators arranged on vehicular components.

[**0115**] Additional variations of any of the embodiments of the method and system described above include the ability of the interrogator or antenna multiplexer to transmit signals from the RFID devices or information derived from the RFID devices to one or more locations or sites remote from the asset containing the RFID device. This allows remote monitoring of assets.

[**0116**] The presence of an interrogator on the same frame or structure which defines a space into which RFID devices or objects equipped with RFID devices greatly simplifies the ability to scan spaces of these frames or structures. The objects equipped with the RFID devices may be sensors. In addition, such sensors may be arranged to be independently interrogated by the interrogator which would thus interrogate the RFID devices and the sensors. These sensors may be temperature, optical, flow, humidity, chemical, biochemical, current, voltage, magnetic field, electric field, force, acceleration, velocity, displacement, a position, vibration, acoustic, radiation, charge, viscosity, density, electrical resistance, electrical impedance, electrical capacitance, electrical inductance and pressure sensors.

[**0117**] The presence and identification of people can be derived using RFID devices, via analysis of information from RFID devices mounted to the vehicle's structure such as seats, and then transmitted off of the vehicle. This concept is disclosed in U.S. Pat. No. 5,829,782, along with the presence of tags and tag monitors inside a vehicle.

[**0118**] The methods and systems described above could also be used to determine the location of RFID devices exterior of a cargo space, yet still within proximity to, on or in a vehicle containing the interrogator.

[**0119**] The power generated by the antennas may be higher in view of the direction of the radio frequency signals into a closed cargo space. In this regard, transmission rules by the FCC may not apply within an enclosed volume with regard to frequencies or power.

[**0120**] The invention is also applicable to the placement of RFID device on luggage or baggage which is placed on airplanes. In this case, a passenger and others can always locate their baggage, provided they have an interrogator or an interrogator is used to determine the location of each passenger's luggage. The system can thus detect and locate

luggage and baggage, or other objects, after it is in a vehicle equipped with an interrogator.

[0121] Another feature of the invention is the use of smart antennas and a single interrogator or reader for use in determining the location of an RFID device or object equipped therewith. Ideally, the method and system would use minimal energy to achieve this location-determination.

[0122] The RFID devices in any of the embodiments herein may utilize an RFID switch, or other techniques, to limit transmissions. MIR may be used to interrogate the RFID devices.

[0123] In one embodiment, transmission via the antennas is based on the location of the antennas. Thus, the interrogator can control the antennas to transmit as a function of the location which is known to the interrogator, or the processor which controls the interrogator.

[0124] For an RFID device or other device which can transmit or generate a return signal at two or more frequencies, it is conceivable that the distance to the RFID device from the antenna can be determined applying a known phase relationship. With multiple antennas, the ability of an RFID device to transmit at two or more frequencies can be used to remove integer ambiguity and thereby get a more accurate distance measurement.

[0125] Since the best position to place antennas on a shipping container or frame of another asset including an interior, object-receiving space, is not always known in advance, a process can be implemented to find the best location for the antennas. This process may entail arranging a large number of antennas on the asset and conducting tests to determine the position of RFID devices in the space. Antennas are removed in stages and more tests conducted until the optimum number and position of antennas for the space which provides an acceptable accuracy is determined.

[0126] RFID devices can be used in combination with SAW devices and other wireless sensors. Many sensors are now in vehicles and many more will be installed in vehicles. The following disclosure is primarily concerned with wireless sensors which can be based on MEMS, SAW and/or RFID technologies. Vehicle sensors include tire pressure, temperature and acceleration monitoring sensors; weight or load measuring sensors; switches; vehicle temperature, acceleration, angular position, angular rate, angular acceleration sensors; proximity; rollover; occupant presence; humidity; presence of fluids or gases; strain; road condition and friction, chemical sensors and other similar sensors providing information to a vehicle system, vehicle operator or external site. The sensors can provide information about the vehicle and/or its interior or exterior environment, about individual components, systems, vehicle occupants, subsystems, and/or about the roadway, ambient atmosphere, travel conditions and external objects.

[0127] For wireless sensors, one or more interrogators can be used each having one or more antennas that transmit energy at radio frequency, or other electromagnetic frequencies, to the sensors and receive modulated frequency signals from the sensors containing sensor and/or identification information. One interrogator can be used for sensing multiple switches or other devices. For example, an interrogator may transmit a chirp form of energy at 905 MHz to 925 MHz to a variety of sensors located within and/or in the vicinity

of the vehicle. These sensors may be of the RFID electronic type and/or of the surface acoustic wave (SAW) type or a combination thereof. In the electronic type, information can be returned immediately to the interrogator in the form of a modulated backscatter RF signal. In the case of SAW devices, the information can be returned after a delay. RFID tags may also exhibit a delay due to the charging of the energy storage device. One sensor can respond in both the electronic (either RFID or backscatter) and SAW-delayed modes.

[0128] When multiple sensors are interrogated using the same technology, the returned signals from the various sensors can be time, code, space or frequency multiplexed. For example, for the case of the SAW technology, each sensor can be provided with a different delay or a different code. Alternately, each sensor can be designed to respond only to a single frequency or several frequencies. The radio frequency can be amplitude, code or frequency modulated. Space multiplexing can be achieved through the use of two or more antennas and correlating the received signals to isolate signals based on direction.

[0129] In many cases, the sensors will respond with an identification signal followed by or preceded by information relating to the sensed value, state and/or property. In the case of a SAW-based or RFID-based switch, for example, the returned signal may indicate that the switch is either on or off or, in some cases, an intermediate state can be provided signifying that a light should be dimmed, rather than on or off, for example. Alternately or additionally, an RFID based switch can be associated with a sensor and turned on or off based on an identification code or a frequency sent from the interrogator permitting a particular sensor or class of sensors to be selected.

[0130] SAW devices have been used for sensing many parameters including devices for chemical and biological sensing and materials characterization in both the gas and liquid phase. They also are used for measuring pressure, strain, temperature, acceleration, angular rate and other physical states of the environment.

[0131] Economies are achieved by using a single interrogator or even a small number of interrogators to interrogate many types of devices. For example, a single interrogator may monitor tire pressure and temperature, the weight of an occupying item of the seat, the position of the seat and seatback, as well as a variety of switches controlling windows, door locks, seat position, etc. in a vehicle. Such an interrogator may use one or multiple antennas and when multiple antennas are used, may switch between the antennas depending on what is being monitored.

[0132] Similarly, the same or a different interrogator can be used to monitor various components of the vehicle's safety system including occupant position sensors, vehicle acceleration sensors, vehicle angular position, velocity and acceleration sensors, related to both frontal, side or rear impacts as well as rollover conditions. The interrogator could also be used in conjunction with other detection devices such as weight sensors, temperature sensors, accelerometers which are associated with various systems in the vehicle to enable such systems to be controlled or affected based on the measured state.

[0133] Some specific examples of the use of interrogators and responsive devices will now be described.

[0134] The antennas used for interrogating the vehicle tire pressure transducers can be located outside of the vehicle passenger compartment. For many other transducers to be sensed the antennas can be located at various positions within passenger compartment. At least one invention herein contemplates, therefore, a series of different antenna systems, which can be electronically switched by the interrogator circuitry. Alternately, in some cases, all of the antennas can be left connected and total transmitted power increased.

[0135] There are several applications for weight or load measuring devices in a vehicle including the vehicle suspension system and seat weight sensors for use with automobile safety systems. As described in U.S. Pat. Nos. 4,096,740, 4,623,813, 5,585,571, 5,663,531, 5,821,425 and 5,910,647 and International Publication No. WO 00/65320(A1), SAW devices are appropriate candidates for such weight measurement systems, although in some cases RFID systems can also be used with an associated sensor such as a strain gage. In this case, the surface acoustic wave on the lithium niobate, or other piezoelectric material, is modified in delay time, resonant frequency, amplitude and/or phase based on strain of the member upon which the SAW device is mounted. For example, the conventional bolt that is typically used to connect the passenger seat to the seat adjustment slide mechanism can be replaced with a stud which is threaded on both ends. A SAW or other strain device can be mounted to the center unthreaded section of the stud and the stud can be attached to both the seat and the slide mechanism using appropriate threaded nuts. Based on the particular geometry of the SAW device used, the stud can result in as little as a 3 mm upward displacement of the seat compared to a normal bolt mounting system. No wires are required to attach the SAW device to the stud other than for an antenna.

[0136] In use, the interrogator transmits a radio frequency pulse at, for example, 925 MHz that excites antenna on the SAW strain measuring system. After a delay caused by the time required for the wave to travel the length of the SAW device, a modified wave is re-transmitted to the interrogator providing an indication of the strain of the stud with the weight of an object occupying the seat corresponding to the strain. For a seat that is normally bolted to the slide mechanism with four bolts, at least four SAW strain sensors could be used. Since the individual SAW devices are very small, multiple devices can be placed on a stud to provide multiple redundant measurements, or permit bending and twisting strains to be determined, and/or to permit the stud to be arbitrarily located with at least one SAW device always within direct view of the interrogator antenna. In some cases, the bolt or stud will be made on non-conductive material to limit the blockage of the RF signal. In other cases, it will be insulated from the slide (mechanism) and used as an antenna.

[0137] If two longitudinally spaced apart antennas are used to receive the SAW or RFID transmissions from the seat weight sensors, one antenna in front of the seat and the other behind the seat, then the position of the seat can be determined eliminating the need for current seat position sensors. A similar system can be used for other seat and seatback position measurements.

[0138] For strain gage weight sensing, the frequency of interrogation can be considerably higher than that of the tire

monitor, for example. However, if the seat is unoccupied, then the frequency of interrogation can be substantially reduced. For an occupied seat, information as to the identity and/or category and position of an occupying item of the seat can be obtained through the multiple weight sensors described. For this reason, and due to the fact that during the pre-crash event, the position of an occupying item of the seat may be changing rapidly, interrogations as frequently as once every 10 milliseconds or faster can be desirable. This would also enable a distribution of the weight being applied to the seat to be obtained which provides an estimation of the center of pressure and thus the position of the object occupying the seat. Using pattern recognition technology, e.g., a trained neural network, sensor fusion, fuzzy logic, etc., an identification of the object can be ascertained based on the determined weight and/or determined weight distribution.

[0139] There are many other methods by which SAW devices can be used to determine the weight and/or weight distribution of an occupying item other than the method described above and all such uses of SAW strain sensors for determining the weight and weight distribution of an occupant are contemplated. For example, SAW devices with appropriate straps can be used to measure the deflection of the seat cushion top or bottom caused by an occupying item, or if placed on the seat belts, the load on the belts can be determined wirelessly and powerlessly. Geometries similar to those disclosed in U.S. Pat. No. 6,242,701 (which discloses multiple strain gage geometries) using SAW strain-measuring devices can also be constructed, e.g., any of the multiple strain gage geometries shown therein.

[0140] Generally there is an RFID implementation that corresponds to each SAW implementation. Therefore, where SAW is used herein the equivalent RFID design will also be meant where appropriate.

[0141] Although a preferred method for using the invention is to interrogate each SAW device using wireless mechanisms, in some cases, it may be desirable to supply power to and/or obtain information from one or more of the SAW devices using wires. As such, the wires would be an optional feature.

[0142] One advantage of the weight sensors of this invention along with the geometries disclosed in the '701 patent and herein below, is that in addition to the axial stress in the seat support, the bending moments in the structure can be readily determined. For example, if a seat is supported by four "legs", it is possible to determine the state of stress, assuming that axial twisting can be ignored, using four strain gages on each leg support for a total of 16 such gages. If the seat is supported by three legs, then this can be reduced to 12 gages. A three-legged support is preferable to four since with four legs, the seat support is over-determined which severely complicates the determination of the stress caused by an object on the seat. Even with three supports, stresses can be introduced depending on the nature of the support at the seat rails or other floor-mounted supporting structure. If simple supports are used that do not introduce bending moments into the structure, then the number of gages per seat can be reduced to three, provided a good model of the seat structure is available. Unfortunately, this is usually not the case and most seats have four supports and the attachments to the vehicle not only introduce bending moments



into the structure but these moments vary from one position to another and with temperature. The SAW strain gages of this invention lend themselves to the placement of multiple gages onto each support as needed to approximately determine the state of stress and thus the weight of the occupant depending on the particular vehicle application. Furthermore, the wireless nature of these gages greatly simplifies the placement of such gages at those locations that are most appropriate.

[0143] An additional point should be mentioned. In many cases, the determination of the weight of an occupant from the static strain gage readings yields inaccurate results due to the indeterminate stress state in the support structure. However, the dynamic stresses to a first order are independent of the residual stress state. Thus, the change in stress that occurs as a vehicle travels down a roadway caused by dips in the roadway can provide an accurate measurement of the weight of an object in a seat. This is especially true if an accelerometer is used to measure the vertical excitation provided to the seat.

[0144] Some vehicle models provide load leveling and ride control functions that depend on the magnitude and distribution of load carried by the vehicle suspension. Frequently, wire strain gage technology is used for these functions. That is, the wire strain gages are used to sense the load and/or load distribution of the vehicle on the vehicle suspension system. Such strain gages can be advantageously replaced with strain gages based on SAW technology with the significant advantages in terms of cost, wireless monitoring, dynamic range, and signal level. In addition, SAW strain gage systems can be more accurate than wire strain gage systems.

[0145] A strain detector in accordance with this invention can convert mechanical strain to variations in electrical signal frequency with a large dynamic range and high accuracy even for very small displacements. The frequency variation is produced through use of a surface acoustic wave (SAW) delay line as the frequency control element of an oscillator. A SAW delay line comprises a transducer deposited on a piezoelectric material such as quartz or lithium niobate which is arranged so as to be deformed by strain in the member which is to be monitored. Deformation of the piezoelectric substrate changes the frequency control characteristics of the surface acoustic wave delay line, thereby changing the frequency of the oscillator. Consequently, the oscillator frequency change is a measure of the strain in the member being monitored and thus the weight applied to the seat. A SAW strain transducer can be more accurate than a conventional resistive strain gage.

[0146] Other applications of weight measuring systems for an automobile include measuring the weight of the fuel tank or other containers of fluid to determine the quantity of fluid contained therein.

[0147] One problem with SAW devices is that if they are designed to operate at the GHz frequency, the feature sizes become exceedingly small and the devices are difficult to manufacture, although techniques are now available for making SAW devices in the tens of GHz range. On the other hand, if the frequencies are considerably lower, for example, in the tens of megahertz range, then the antenna sizes become excessive. It is also more difficult to obtain antenna gain at the lower frequencies. This is also related to antenna

size. One method of solving this problem is to transmit an interrogation signal in the high GHz range which is modulated at the hundred MHz range. At the SAW transducer, the transducer is tuned to the modulated frequency. Using a nonlinear device such as a Shocky diode, the modified signal can be mixed with the incoming high frequency signal and re-transmitted through the same antenna. For this case, the interrogator can continuously broadcast the carrier frequency.

[0148] Devices based on RFID or SAW technology can be used as switches in a vehicle as described in U.S. Pat. Nos. 6,078,252, 6,144,288 and 6,748,797. There are many ways that this can be accomplished. A switch can be used to connect an antenna to either an RFID electronic device or to a SAW device. This requires contacts to be closed by the switch activation. An alternate approach is to use pressure from an occupant's finger, for example, to alter the properties of the acoustic wave on the SAW material such as in a SAW touch screen. The properties that can be modified include the amplitude of the acoustic wave, and its phase, and/or the time delay or an external impedance connected to one of the SAW reflectors as disclosed in U.S. Pat. No. 6,084,503. In this implementation, the SAW transducer can contain two sections, one which is modified by the occupant and the other which serves as a reference. A combined signal is sent to the interrogator that decodes the signal to determine that the switch has been activated. By any of these technologies, switches can be arbitrarily placed within the interior of an automobile, for example, without the need for wires. Since wires and connectors are the cause of most warranty repairs in an automobile, not only is the cost of switches substantially reduced but also the reliability of the vehicle electrical system is substantially improved.

[0149] The interrogation of switches can take place with moderate frequency such as once every 100 milliseconds. Either through the use of different frequencies or different delays, a large number of switches can be time, code, space and/or frequency multiplexed to permit separation of the signals obtained by the interrogator. Alternately, an RF activated switch on some or all of the sensors can be used as discussed below.

[0150] Another approach is to attach a variable impedance device across one of the reflectors on the SAW device. The impedance can therefore be used to determine the relative reflection from the reflector compared to other reflectors on the SAW device. In this manner, the magnitude as well as the presence of a force exerted by an occupant's finger, for example, can be used to provide a rate sensitivity to the desired function. In an alternate design, as shown in U.S. Pat. No. 6,144,288, the switch is used to connect the antenna to the SAW device. In this case, the interrogator will not get a return from the SAW switch unless it is depressed.

[0151] Temperature measurement is another field in which SAW technology can be applied and the invention encompasses several embodiments of SAW temperature sensors.

[0152] U.S. Pat. No. 4,249,418 is one of many examples of prior art SAW temperature sensors. Temperature sensors are commonly used within vehicles and many more applications might exist if a low cost wireless temperature sensor is available such as disclosed herein. The SAW technology can be used for such temperature sensing tasks. These tasks include measuring the vehicle coolant temperature, air tem-

perature within passenger compartment at multiple locations, seat temperature for use in conjunction with seat warming and cooling systems, outside temperatures and perhaps tire surface temperatures to provide early warning to operators of road freezing conditions. One example, is to provide air temperature sensors in the passenger compartment in the vicinity of ultrasonic transducers used in occupant sensing systems as described in U.S. Pat. No. 5,943,295 (Varga et al.), since the speed of sound in the air varies by approximately 20% from  $-40^{\circ}$  C. to  $85^{\circ}$  C. Current ultrasonic occupant sensor systems do not measure or compensate for this change in the speed of sound with the effect of reducing the accuracy of the systems at the temperature extremes. Through the judicious placement of SAW temperature sensors in the vehicle, the passenger compartment air temperature can be accurately estimated and the information provided wirelessly to the ultrasonic occupant sensor system thereby permitting corrections to be made for the change in the speed of sound.

**[0153]** Since the road can be either a source or a sink of thermal energy, strategically placed sensors that measure the surface temperature of a tire can also be used to provide an estimate of road temperature.

**[0154]** Acceleration sensing is another field in which SAW technology can be applied and the invention encompasses several embodiments of SAW accelerometers.

**[0155]** U.S. Pat. Nos. 4,199,990, 4,306,456 and 4,549,436 are examples of prior art SAW accelerometers. Airbag crash sensors for determining whether the vehicle is experiencing a frontal or side impact often use micromachined accelerometers. These accelerometers are usually based on the deflection of a mass which is sensed using either capacitive or piezoresistive technologies. SAW technology has previously not been used as a vehicle accelerometer or for vehicle crash sensing. Due to the importance of this function, at least one interrogator could be dedicated to this critical function. Acceleration signals from the crash sensors should be reported at least preferably every 100 microseconds. In this case, the dedicated interrogator would send an interrogation pulse to all crash sensor accelerometers every 100 microseconds and receive staggered acceleration responses from each SAW accelerometer wirelessly. This technology permits the placement of multiple low-cost accelerometers at ideal locations for crash sensing including inside the vehicle side doors, in the passenger compartment and in the frontal crush zone. Additionally, crash sensors can now be located in the rear of the vehicle in the crush zone to sense rear impacts. Since the acceleration data is transmitted wirelessly, concern about the detachment or cutting of wires from the sensors disappears. One of the main concerns, for example, of placing crash sensors in the vehicle doors where they most appropriately can sense vehicle side impacts, is the fear that an impact into the A-pillar of the automobile would sever the wires from the door-mounted crash sensor before the crash was sensed. This problem disappears with the wireless technology of this invention. If two accelerometers are placed at some distance from each other, the roll acceleration of the vehicle can be determined and thus the tendency of the vehicle to rollover can be predicted in time to automatically take corrective action and/or deploy a curtain airbag or other airbag(s). Other types of sensors such as crash sensors based on pressure measurements, such as supplied by Siemens, can also now be wireless.

**[0156]** Although the sensitivity of measurement is considerably greater than that obtained with conventional piezoelectric or micromachined accelerometers, the frequency deviation of SAW devices re-mains low (in absolute value). Accordingly, the frequency drift of thermal origin should be made as low as possible by selecting a suitable cut of the piezoelectric material. The resulting accuracy is impressive as presented in U.S. Pat. No. 4,549,436, which discloses an angular accelerometer with a dynamic range of 1 million, temperature coefficient of 0.005%/deg F, an accuracy of 1 microradian/sec<sup>2</sup>, a power consumption of 1 milliwatt, a drift of 0.01% per year, a volume of 1 cc/axis and a frequency response of 0 to 1000 Hz. The subject matter of the '436 patent is hereby included in the invention to constitute a part of the invention. A similar design can be used for acceleration sensing.

**[0157]** In a similar manner as the polymer-coated SAW device is used to measure pressure, a device wherein a seismic mass is attached to a SAW device through a polymer interface can be made to sense acceleration. This geometry has a particular advantage for sensing accelerations below 1 G, which has proved to be very difficult for conventional micro-machined accelerometers due to their inability to both measure low accelerations and withstand high acceleration shocks.

**[0158]** Gyroscopes are another field in which SAW technology can be applied and the inventions herein encompass several embodiments of SAW gyroscopes.

**[0159]** SAW technology is particularly applicable for gyroscopes as described in International Publication No. WO 00/79217A2 to Varadan et al. The output of such gyroscopes can be determined with an interrogator that is also used for the crash sensor accelerometers, or a dedicated interrogator can be used. Gyroscopes having an accuracy of approximately 1 degree per second have many applications in a vehicle including skid control and other dynamic stability functions. Additionally, gyroscopes of similar accuracy can be used to sense impending vehicle rollover situations in time to take corrective action.

**[0160]** The inventor has represented that SAW gyroscopes of the type described in WO 00/79217A2 have the capability of achieving accuracies approaching about 3 degrees per hour. This high accuracy permits use of such gyroscopes in an inertial measuring unit (IMU) that can be used with accurate vehicle navigation systems and autonomous vehicle control based on differential GPS corrections. Such a system is described in U.S. Pat. No. 6,370,475. An alternate preferred technology for an IMU is described in U.S. Pat. No. 4,711,125. Such navigation systems depend on the availability of four or more GPS satellites and an accurate differential correction signal such as provided by the OmniStar Corporation, NASA or through the National Differential GPS system now being deployed. The availability of these signals degrades in urban canyon environments, in tunnels and on highways when the vehicle is in the vicinity of large trucks. For this application, an IMU system should be able to accurately control the vehicle for perhaps 15 seconds and preferably for up to five minutes. IMUs based on SAW technology, the technology of U.S. Pat. No. 4,549,436 or of U.S. Pat. No. 4,711,125 are the best-known devices capable of providing sufficient accuracies for this application at a reasonable cost. Other accurate gyroscope

technologies such as fiber optic systems are more accurate but can be cost-prohibitive, although analysis has indicated that such gyroscopes can eventually be made cost-competitive. In high volume production, an IMU of the required accuracy based on SAW technology is estimated to cost less than about \$100. A cost competing technology is that disclosed in U.S. Pat. No. 4,711,125 which does not use SAW technology.

**[0161]** What follows is a discussion of the Morrison Cube of U.S. Pat. No. 4,711,125 known as the QUBIK™. Typical problems that are encountered with sensors that try to measure multiple physical quantities at the same time and how the QUBIK solves these problems are set forth below.

**[0162]** 1. Problem: Errors of measurement of the linear accelerations and angular speed are mutually correlated. Even if every one of the errors, taken separately, does not accumulate with integration (the inertial system's algorithm does that), the cross-coupled multiplication (such as one during re-projecting the linear accelerations from one coordinate system to another) will have these errors detected and will make them a systematic error similar to a sensor's bias.

**[0163]** Solution: The QUBIK IMU is calibrated and compensated for any cross axis sensitivity. For example: if one of the angular accelerometer channels has a sensitivity to any of the three of linear accelerations, then the linear accelerations are buffered and scaled down and summed with the buffered angular accelerometer output to cancel out all linear acceleration sensitivity on all three angular accelerometer channels. This is important to detect pure angular rate signals. This is a very common practice throughout the U.S. aerospace industry to make navigation grade IMU's. Even when individual gyroscopes and accelerometers are used in navigation, they have their outputs scaled and summed together to cancel out these cross axis errors. Note that competitive MEMS products have orders of magnitude higher cross axis sensitivities when compared to navigation grade sensors and they will undoubtedly have to use this practice to improve performance. MEMS angular rate sensors are advertised in degrees per second and navigation angular rate sensors are advertised in degrees per hour. MEMS angular rate sensors have high linear acceleration errors that must be compensated for at the IMU level.

**[0164]** 2. Problem: The gyroscope and accelerometer channels require settings to be made that contradict one another physically. For example, a gap between the cube and the housing for the capacitive sensors (that measure the displacements of the cube) is not to exceed 50 to 100 microns. On the other hand, the gyroscope channels require, in order to enhance a Coriolis effect used to measure the angular speed, that the amplitude and the linear speed of vibrations are as big as possible. To do this, the gap and the frequency of oscillations should be increased. A greater frequency of oscillations in the nearly resonant mode requires the stiffness of the electromagnetic suspension to be increased, too, which leads to a worse measurement of the linear accelerations because the latter require that the rigidity of the suspension be minimal when there is a closed feedback.

**[0165]** Solution: The capacitive gap all around the levitated inner cube of the QUBIK is nominally 0.010 inches. The variable capacitance plates are excited by a 1.5 MHz 25 volt peak to peak signal. The signal coming out is so strong

(five volts) that there is no preamp required. Diode detectors are mounted directly above the capacitive plates. There is no performance change in the linear accelerometer channels when the angular accelerometer channels are being dithered or rotated back and forth about an axis. This was discovered by having a ground plane around the electromagnets that eliminated transformer coupling. Dithering or driving the angular accelerometer which rotates the inner cube proof mass is a gyroscopic displacement and not a linear displacement and has no effect on the linear channels. Another very important point to make is the servo loops measure the force required to keep the inner cube at its null and the servo loops are integrated to prevent any displacements. The linear accelerometer servo loops are not being exercised to dither the inner cube. The angular accelerometer servo loop is being exercised. The linear and angular channels have their own separate set of capacitance detectors and electromagnets. Driving the angular channels has no effect on the linear ones.

**[0166]** The rigidity of an integrated closed loop servo is infinite at DC and rolls off at higher frequencies. The QUBIK IMU measures the force being applied to the inner cube and not the displacement to measure angular rate. There is a force generated on the inner cube when it is being rotated and the servo will not allow any displacement by applying equal and opposite forces on the inner cube to keep it at null. The servo readout is a direct measurement of the gyroscopic forces on the inner cube and not the displacement.

**[0167]** The servo gain is so high at the null position that one will not see the null displacement but will see a current level equivalent to the force on the cube. This is why integrated closed loop servos are so good. They measure the force required to keep the inner cube at null and not the displacement. The angular accelerometer channel that is being dithered will have a noticeable displacement at its null. The sensor does not have to be driven at its resonance. Driving the angular accelerometer at resonance will run the risk of over-driving the inner cube to the point where it will bottom out and bang around inside its cavity. There is an active gain control circuit to keep the alternating momentum constant.

**[0168]** Note that competitive MEMS based sensors are open loop and allow displacements which increase cross axis errors. MEMS sensors must have displacements to work and do not measure the Coriolis force, they measure displacement which results in huge cross axis sensitivity issues.

**[0169]** 3. Problem: As the electromagnetic suspension is used, the sensor is going to be sensitive to external constant and variable (alternating) fields. Its errors will vary with its position, for example, with respect to the Earth's magnetic field or other magnetic sources.

**[0170]** Solution: The earth's magnetic field varies from -0.0 to +0.3 gauss and the magnets have gauss levels over 10,000. The earth field can be shielded if necessary.

**[0171]** 4. Problem: The QUBIT sensing element is relatively heavy so the sensor is likely to be sensitive to angular accelerations and impacts. Also, the temperature of the environment can affect the micron-sized gaps, magnetic fields of the permanent magnets, the resistance of the inductance coils etc., which will eventually increase the sensor errors.

[0172] Solution: The inner cube has a gap of 0.010 inches and does not change significantly over temperature.

[0173] The resistance of the coils is not a factor in the active closed loop servo. Anybody who make this statement does not know what they are talking about. There is a stable one PPM/C current readout resistor in series with the coil that measures the current passing through the coil which eliminates the temperature sensitivity of the coil resistance.

[0174] Permanent magnets have already proven themselves to be very stable over temperature when used in active servo loops used in navigation gyroscopes and accelerometers.

[0175] Note that the sensitivity that the QUBIK IMU has achieved 0.01 degrees per hour.

[0176] 5. Problem: High Cost. To produce the QUBIK, one may need to maintain micron-sized gaps and highly clean surfaces for capacitive sensors; the devices must be assembled in a dust-free room, and the device itself must be hermetic (otherwise dust or moisture will put the capacitive sensor and the electromagnetic suspension out of operation), the permanent magnets must have a very stable performance because they're going to work in a feedback circuit, and so on. In our opinion, all these issues make the technology overly complex and expensive, so an additional metrological control will be required and no full automation can be ever done.

[0177] Solution: The sensor does not have micron size gaps and does not need to be hermetic unless the sensor is submerged in water! Most of the QUBIK IMU sensor is a cut out PCB's that can certainly be automated. The PCB design can keep dust out and does not need to be hermetic. Humidity is not a problem unless the sensor is submerged in water. The permanent magnets achieve parts per million stability at a cost of \$0.05 each for a per system cost of under one dollar. There are may navigation grade gyroscopes and accelerometers that use permanent magnets.

[0178] Competitive MEMS sensors can have process contamination problems. To my knowledge, there are no MEMS angular rate sensors that do not require human labor and/or calibration. The QUBIK IMU can instead use programmable potentiometers at calibration instead of human labor.

[0179] Once an IMU of the accuracy described above is available in the vehicle, this same device can be used to provide significant improvements to vehicle stability control and rollover prediction systems.

[0180] Keyless entry systems are another field in which SAW technology can be applied and the invention encompasses several embodiments of access control systems using SAW devices.

[0181] A common use of SAW or RFID technology is for access control to buildings however, the range of electronic unpowered RFID technology is usually limited to one meter or less. In contrast, the SAW technology, when powered or boosted, can permit sensing up to about 30 meters. As a keyless entry system, an automobile can be configured such that the doors unlock as the holder of a card containing the SAW ID system approaches the vehicle and similarly, the vehicle doors can be automatically locked when the occupant with the card travels beyond a certain distance from the vehicle. When the occupant enters the vehicle, the doors can

again automatically lock either through logic or through a current system wherein doors automatically lock when the vehicle is placed in gear. An occupant with such a card would also not need to have an ignition key. The vehicle would recognize that the SAW-based card was inside vehicle and then permit the vehicle to be started by issuing an oral command if a voice recognition system is present or by depressing a button, for example, without the need for an ignition key.

[0182] SAW sensors operating in the wireless mode can also be used to sense for ice on the windshield or other exterior surfaces of the vehicle, condensation on the inside of the windshield or other interior surfaces, rain sensing, heat-load sensing and many other automotive sensing functions. They can also be used to sense outside environmental properties and states including temperature, humidity, etc.

[0183] SAW sensors can be economically used to measure the temperature and humidity at numerous places both inside and outside of a vehicle. When used to measure humidity inside the vehicle, a source of water vapor can be activated to increase the humidity when desirable and the air conditioning system can be activated to reduce the humidity when necessary or desirable. Temperature and humidity measurements outside of the vehicle can be an indication of potential road icing problems. Such information can be used to provide early warning to a driver of potentially dangerous conditions. Although the invention described herein is related to land vehicles, many of these advances are equally applicable to other vehicles such as airplanes and even, in some cases, homes and buildings. The invention disclosed herein, therefore, is not limited to automobiles or other land vehicles.

[0184] Road condition sensing is another field in which SAW technology can be applied and the invention encompasses several embodiments of SAW road condition sensors.

[0185] The temperature and moisture content of the surface of a roadway are critical parameters in determining the icing state of the roadway. Attempts have been made to measure the coefficient of friction between a tire and the roadway by placing strain gages in the tire tread. Such strain gages are ideal for the application of SAW technology especially since they can be interrogated wirelessly from a distance and they require no power for operation. As discussed herein, SAW accelerometers can also perform this function. Measurement of the friction coefficient, however, is not predictive and the vehicle operator is only able to ascertain the condition after the fact. Boosted SAW or RFID based transducers have the capability of being interrogated as much as 100 feet from the interrogator. Therefore, judicious placement of low-cost powerless SAW or RFID temperature and humidity sensors in and/or on the roadway at critical positions can provide an advance warning to vehicle operators that the road ahead is slippery. Such devices are very inexpensive and therefore could be placed at frequent intervals along a highway.

[0186] An infrared sensor that looks down the highway in front of the vehicle can actually measure the road temperature prior to the vehicle traveling on that part of the roadway. This system also would not give sufficient warning if the operator waited for the occurrence of a frozen roadway. The probability of the roadway becoming frozen, on the other hand, can be predicted long before it occurs, in most cases,

by watching the trend in the temperature. Once vehicle-to-vehicle communications are common, roadway icing conditions can be communicated between vehicles.

[0187] Some lateral control of the vehicle can also be obtained from SAW transducers or electronic RFID tags placed down the center of the lane, either above the vehicles and/or in the roadway, for example. A vehicle having two receiving antennas, for example, approaching such devices, through triangulation or direct proportion, is able to determine the lateral location of the vehicle relative to these SAW devices. If the vehicle also has an accurate map of the roadway, the identification number associated with each such device can be used to obtain highly accurate longitudinal position determinations. Ultimately, the SAW devices can be placed on structures beside the road and perhaps on every mile or tenth of a mile marker. If three antennas are used, as discussed herein, the distances from the vehicle to the SAW device can be determined. These SAW devices can be powered in order to stay below current FCC power transmission limits. Such power can be supplied by a photocell, energy harvesting where applicable, by a battery or power connection.

[0188] Electronic RFID tags are also suitable for lateral and longitudinal positioning purposes, however, the range available for current electronic RFID systems can be less than that of SAW-based systems unless either are powered. On the other hand, as disclosed in U.S. Pat. No. 6,748,797, the time-of-flight of the RFID system can be used to determine the distance from the vehicle to the RFID tag. Because of the inherent delay in the SAW devices and its variation with temperature, accurate distance measurement is probably not practical based on time-of-flight but somewhat less accurate distance measurements based on relative time-of-arrival can be made. Even if the exact delay imposed by the SAW device was accurately known at one temperature, such devices are usually reasonably sensitive to changes in temperature, hence they make good temperature sensors, and thus the accuracy of the delay in the SAW device is more difficult to maintain. An interesting variation of an electronic RFID that is particularly applicable to this and other applications of this invention is described in A. Pohl, L. Reindl, "New passive sensors", Proc. 16th IEEE Instrumentation and Measurement Technology Conf., IMTC/99, 1999, pp. 1251-1255.

[0189] Many SAW devices are based on lithium niobate or similar strong piezoelectric materials. Such materials have high thermal expansion coefficients. An alternate material is quartz that has a very low thermal expansion coefficient. However, its piezoelectric properties are inferior to lithium niobate. One solution to this problem is to use lithium niobate as the coupling system between the antenna and the material or substrate upon which the surface acoustic wave travels. In this manner, the advantages of a low thermal expansion coefficient material can be obtained while using the lithium niobate for its strong piezoelectric properties. Other useful materials such as Langasite™ have properties that are intermediate between lithium niobate and quartz.

[0190] The use of SAW tags as an accurate precise positioning system as described above would be applicable for accurate vehicle location, as discussed in U.S. Pat. No. 6,370,475, for lanes in tunnels, for example, or other cases where loss of satellite lock, and thus the primary vehicle location system, is common.

[0191] The various technologies discussed above can be used in combination. The electronic RFID tag can be incorporated into a SAW tag providing a single device that provides both a quick reflection of the radio frequency waves as well as a re-transmission at a later time. This marriage of the two technologies permits the strengths of each technology to be exploited in the same device. For most of the applications described herein, the cost of mounting such a tag in a vehicle or on the roadway far exceeds the cost of the tag itself. Therefore, combining the two technologies does not significantly affect the cost of implementing tags onto vehicles or roadways or side highway structures.

[0192] A variation of this design is to use an RF circuit such as in an RFID to serve as an energy source. One design could be for the RFID to operate with directional antennas at a relatively high frequency such as 2.4 GHz. This can be primarily used to charge a capacitor to provide the energy for boosting the signal from the SAW sensor using circuitry such as a circulator discussed below. The SAW sensor can operate at a lower frequency, such as 400 MHz, permitting it to not interfere with the energy transfer to the RF circuit and also permit the signal to travel better to the receiver since it will be difficult to align the antenna at all times with the interrogator. Also, by monitoring the reception of the RF signal, the angular position of the tire can be determined and the SAW circuit designed so that it only transmits when the antennas are aligned or when the vehicle is stationary. Many other opportunities now present themselves with the RF circuit operating at a different frequency from the SAW circuit which will now be obvious to one skilled in the art.

[0193] An alternate method to the electronic RFID tag is to simply use a radar or lidar reflector and measure the time-of-flight to the reflector and back. The reflector can even be made of a series of reflecting surfaces displaced from each other to achieve some simple coding. It should be understood that RFID antennas can be similarly configured. An improvement would be to polarize the radiation and use a reflector that rotates the polarization angle allowing the reflector to be more easily found among other reflecting objects.

[0194] FIG. 11 illustrates a vehicle passenger compartment, and the engine compartment, with multiple SAW or RFID temperature sensors 85. SAW temperature sensors can be distributed throughout the passenger compartment, such as on the A-pillar, on the B-pillar, on the steering wheel, on the seat, on the ceiling, on the headliner, and on the windshield, rear and side windows and generally in the engine compartment. These sensors, which can be independently coded with different IDs and/or different delays, can provide an accurate measurement of the temperature distribution within the vehicle interior. RFID switches can also be used to isolate one device from another. Such a system can be used to tailor the heating and air conditioning system based on the temperature at a particular location in the passenger compartment. If this system is augmented with occupant sensors, then the temperature can be controlled based on seat occupancy and the temperature at that location. If the occupant sensor system is based on ultrasonics, then the temperature measurement system can be used to correct the ultrasonic occupant sensor system for the speed of sound within the passenger compartment. Without such a correction, the error in the sensing system can be as large as about 20 percent.

[0195] The SAW temperature sensors **85** provide the temperature at their mounting location to a processor unit **83** via an interrogator with the processor unit **83** including appropriate control algorithms for controlling the heating and air conditioning system based on the detected temperatures. The processor unit **83** can control, e.g., which vents in the vehicle are open and closed, the flow rate through vents and the temperature of air passing through the vents. In general, the processor unit **83** can control whatever adjustable components are present or form part of the heating and air conditioning system.

[0196] All of the elements of the system which adjusts or controls the vehicle components in any of the embodiments described herein, i.e., the sensors, processing unit and reactive system which is controlled by the processing unit based on the data sensed by the sensors, can be arranged within the vehicle. They could be fixed to the frame of the vehicle, and/or arranged in an interior defined by the frame, with the sensor assemblies (the sensor and wireless transmission component associated therewith) fixed relative to the processor unit or receiver which contains the antenna capable of receiving the signals being transmitted wirelessly from the wireless transmission component of the sensor assemblies. In some embodiments, the sensor assemblies are arranged on parts of the vehicle which are not fixed to the frame or fixed relative to the processor unit or receiver, such as on the tires, but in other embodiments, the sensor assemblies are arranged only on parts fixed to the frame. This fixed relationship between the sensor assemblies and the receiver(s) associated with the processing unit allows for proper positioning of the receivers to communicate with all designated sensor assemblies.

[0197] In FIG. 11, a child seat **87** is illustrated on the rear vehicle seat. The child seat **87** can be fabricated with one or more RFID tags or SAW tags (not shown). The RFID and SAW tag(s) can be constructed to provide information on the occupancy of the child seat, i.e., whether a child is present, based on the weight, temperature, and/or any other measurable parameter. Also, the mere transmission of waves from the RFID or SAW tag(s) on the child seat **87** would be indicative of the presence of a child seat. The RFID and SAW tag(s) can also be constructed to provide information about the orientation of the child seat **87**, i.e., whether it is facing rearward or forward. Such information about the presence and occupancy of the child seat and its orientation can be used in the control of vehicular systems, such as the vehicle airbag system or heating or air conditioning system, especially useful when a child is left in a vehicle. In this case, a processor would control the airbag or HVAC system and would receive information from the RFID and SAW tag(s) via an interrogator.

[0198] SAW sensors also have applicability to various other sectors of the vehicle, including the powertrain, chassis, and occupant comfort and convenience. For example, SAW and RFID sensors have applicability to sensors for the powertrain area including oxygen sensors, gear-tooth Hall effect sensors, variable reluctance sensors, digital speed and position sensors, oil condition sensors, rotary position sensors, low pressure sensors, manifold absolute pressure/manifold air temperature (MAP/MAT) sensors, medium pressure sensors, turbo pressure sensors, knock sensors, coolant/fluid temperature sensors, and transmission temperature sensors.

[0199] SAW sensors for chassis applications include gear-tooth Hall effect sensors, variable reluctance sensors, digital speed and position sensors, rotary position sensors, non-contact steering position sensors, and digital ABS (anti-lock braking system) sensors. In one implementation, a Hall Effect tire pressure monitor comprises a magnet that rotates with a vehicle wheel and is sensed by a Hall Effect device which is attached to a SAW or RFID device that is wirelessly interrogated. This arrangement eliminates the need to run a wire into each wheel well.

[0200] FIG. 12 illustrates the placement of a variety of sensors, primarily accelerometers and/or gyroscopes, which can be used to diagnose the state of the vehicle itself. Sensor **105** can be located in the headliner or attached to the vehicle roof above the side door. Typically, there can be two such sensors one on either side of the vehicle. Sensor **106** is shown in a typical mounting location midway between the sides of the vehicle attached to or near the vehicle roof above the rear window. Sensor **109** is shown in a typical mounting location in the vehicle trunk adjacent the rear of the vehicle. One, two or three such sensors can be used depending on the application. If three such sensors are used, preferably one would be adjacent each side of vehicle and one in the center. Sensor **107** is shown in a typical mounting location in the vehicle door and sensor **108** is shown in a typical mounting location on the sill or floor below the door. Sensor **110**, which can be also multiple sensors, is shown in a typical mounting location forward in the crush zone of the vehicle. Finally, sensor **111** can measure the acceleration of the firewall or instrument panel and is located thereon generally midway between the two sides of the vehicle. If three such sensors are used, one would be adjacent each vehicle side and one in the center. An IMU would serve basically the same functions.

[0201] In general, sensors **105-111** provide a measurement of the state of the vehicle, such as its velocity, acceleration, angular orientation or temperature, or a state of the location at which the sensor is mounted. Thus, measurements related to the state of the sensor would include measurements of the acceleration of the sensor, measurements of the temperature of the mounting location as well as changes in the state of the sensor and rates of changes of the state of the sensor. As such, any described use or function of the sensors **105-111** above is merely exemplary and is not intended to limit the form of the sensor or its function. Thus, these sensors may or may not be SAW or RFID sensors and may be powered or unpowered and may transmit their information through a wire harness, a safety or other bus or wirelessly.

[0202] Each sensor **105-111** may be single axis, double axis or triaxial accelerometers and/or gyroscopes typically of the MEMS type. One or more can be IMUs. These sensors **105-111** can either be wired to the central control module or processor directly wherein they would receive power and transmit information, or they could be connected onto the vehicle bus or, in some cases, using RFID, SAW or similar technology, the sensors can be wireless and would receive their power through RF from one or more interrogators located in the vehicle. In this case, the interrogators can be connected either to the vehicle bus or directly to control module. Alternately, an inductive or capacitive power and/or information transfer system can be used.

[0203] The driver can be provided with a keyless entry device, other RFID tag, smart card or cell phone with an RF

transponder that can be powerless in the form of an RFID or similar device, which can also be boosted as described herein. Generally, such keyless entry devices can be considered a portable identification device. The interrogator, or a processing unit associated therewith, determines the proximity of the driver to the vehicle door or other similar object such as a building or house door or vehicle trunk. As shown in FIG. 13, if a driver 118 remains within a certain distance, 1 meter for example, from the door or trunk lid 116, for example, for a certain time period such as 5 seconds, then the door or trunk lid 116 can automatically unlock and even open in some implementations. The distance and time period can be selected or determined as desired. Thus, as the driver 118 approaches the trunk with his or her arms filled with packages 117 and pauses, the trunk can automatically open (see FIG. 14). Such a system would be especially valuable for older people. This system can also be used for other systems in addition to vehicle doors and trunk lids.

[0204] As shown in FIG. 15, an interrogator 115 is placed on the vehicle, e.g., in the trunk 112 as shown, and transmits waves. When the keyless entry device 113, which contains an antenna 114 and a circuit including a circulator 135 and a memory containing a unique ID code 136, is a set distance from the interrogator 115 for a certain duration of time, the interrogator 115 directs a trunk opening device 137 to open the trunk lid 116. The duration of time is determined from the continuous reception by the interrogator 115 of the ID code 136 from the keyless entry device 113.

[0205] A SAW device can also be used as a wireless switch as shown in FIGS. 16A and 16B. FIG. 16A illustrates a surface 120 containing a projection 122 on top of a SAW device 121. Surface material 120 could be, for example, the armrest of an automobile, the steering wheel airbag cover, or any other surface within the passenger compartment of an automobile or elsewhere. Projection 122 will typically be a material capable of transmitting force to the surface of SAW device 121. As shown in FIG. 16B, a projection 123 may be placed on top of the SAW device 124. This projection 123 permits force exerted on the projection 122 to create a pressure on the SAW device 124. This increased pressure changes the time delay or natural frequency of the SAW wave traveling on the surface of material. Alternately, it can affect the magnitude of the returned signal. The projection 123 is typically held slightly out of contact with the surface until forced into contact with it.

[0206] An alternate approach is to place a switch across the IDT 127 as shown in FIG. 16C. If switch 125 is open, then the device will not return a signal to the interrogator. If it is closed, then the IDT 127 will act as a reflector sending a signal back to IDT 128 and thus to the interrogator. Alternately, a switch 126 can be placed across the SAW device. In this case, a switch closure shorts the SAW device and no signal is returned to the interrogator. For the embodiment of FIG. 16C, using switch 126 instead of switch 125, a standard reflector IDT would be used in place of the IDT 127.

[0207] FIG. 16D shows an embodiment wherein a radio-frequency identification device (RFID) is controlled by a switch 129A, and may be one of the wireless transmission components of a switch assembly. The switch 129A may be a conventional, mechanical switch such as a push button, toggle and the like. A switch assembly would therefore

comprise the RFID, the switch 129A and an antenna 119A which may constitute another wireless transmission component. In this case, when the user presses on an exposed surface of the passenger compartment, he or she would close the switch 129A and thereby short the RFID so that it would be inoperative. That is, the RFID would not respond when interrogated. Instead of a switch, a variable impedance could also be provided which would modify the output of the RFID based on the magnitude of pressure to the exposed surface. Instead of using the switch or variable impedance, another control mechanism for causing variation in the transmission by the wireless transmission components of the switch assembly can be provided. In this embodiment, as well as the other embodiments herein wherein an RFID is provided, the RFID can be either a passive RFID or an active RFID. In the latter case, the RFID is supplied with power from a power source on the vehicle, such as the vehicle's battery, a local battery, photo cell, or a local energy generator or harvester.

[0208] FIGS. 16C and 16D are examples of manually activated RFID switch assemblies which could be used in a vehicular component control system to adjust various components based on user action. For example, each switch assembly could control a respective component with a processor unit of the control system being coupled to or included within an interrogator arranged to transmit RF signals having identification data associated with the RFID switch assemblies such that upon transmission of each RF signal, any RFID switch assemblies with matching identification data would be capable of providing responsive signals. In particular, the RFID switch assemblies provide output based on pressure applied by the occupant of the vehicle to an exposed surface and includes an RF transmission component arranged to wirelessly transmit an indication of the application of pressure to the exposed surface. This indication may be the magnitude of the pressure being applied (e.g., via the switch assembly of FIG. 16C) or the absence of a signal (e.g., via the short-circuited RFID of FIG. 16D). Other input devices for use in the same component control system include those described elsewhere herein, for example, an RFID assembly including a sensor and an RFID switch which could receive an RF signal from the same interrogator and upon receipt of a signal containing its identification, enable transmission of a signal from the sensor from which a property being monitored by the sensor is determinable. Another input device is an RFID assembly including a sensor and an RFID switch which is arranged to receive an RF signal from the same interrogator and upon receipt of a signal not containing its identification, disable transmission of an RF signal from the interrogator to the sensor for its excitation, from which sensor a property being monitored by the sensor is determinable.

[0209] FIG. 16H shows another switch assembly for controlling a component which includes an energy storage and/or transmission component 443 which may comprise an RFID so that when the switch assembly is activated, the RFID 443 is able to respond to an interrogation signal from an interrogator associated with the component control system. The RFID switch assembly includes a piezoelectric energy generator switch 441 underlying an exposed surface 440 of the vehicle and formed by a plurality of sheets of a piezoelectric material, such as polyvinylidene fluoride (PVDF), and generates power upon application of pressure to the exposed surface 440. The generated power is usable

to power the transmission component, i.e., the RFID. The stack of PVDF sheets are placed over supports 442 and can include a snap action mechanism, not shown, to provide a snap action switch.

[0210] PVDF is a known inexpensive material capable of use in vehicles. PVDF is also usable as a SAW-type device and would be especially applicable where there is external power provided. The presence of available energy could lead to certain advantages of the use of PVDF such as for chemical sensing since it could be much larger than other sensing equivalents, such as lithium Niobate, and therefore more likely to capture the chemical. As an energy generator, PVDF has much more applicability since a number of layers can be stacked thereby multiplying its energy output. The switch shown in FIG. 16H can be made, for example, so that it gets its power from someone snapping the stack of PVDF sheets 441 between supports 442 in a snap action switch. The power generated could send a signal to a receiver or alternatively, it could be used to power the RFID 443 thereby giving an ID transmission relating to the switching action which is indicative of a desired action by the occupant of the vehicle and thus could be used to control an adjustable component.

[0211] Such a PVDF switch could be used in those cases where a switching or sensing function covering a broad area is desired. The sensing of the contact of the head with a headrest would be one example. In this case, the stack of PVDF sheets is arranged in the headrest below the covering of the headrest and when an occupant rests his or her head against the headrest, the PVDF sheets are compressed thereby generating power for an RFID to respond to an interrogator signal. The return signal to the interrogator would therefore be indicative of the presence of an occupant, or other object, resting against the headrest. Of course, many other arrangements will be obvious to one skilled in the art.

[0212] FIG. 16E shows an embodiment wherein a surface-acoustic-wave (SAW) device is controlled by a switch 129B, and may be one of the wireless transmission components of a switch assembly. The switch 129B may be a conventional, mechanical switch such as a push button, toggle and the like. A switch assembly would therefore comprise the SAW device, the switch 129B and an antenna 119B which may constitute another a wireless transmission component. In this case, when the user presses on an exposed surface of the passenger compartment, he or she would close the switch 129B and thereby prevent the SAW device from receiving a signal so that it would be inoperative. Instead of a switch, a variable impedance could also be provided which would modify the output of the SAW device based on the magnitude of pressure to the exposed surface. Instead of using the switch or variable impedance, another control mechanism for causing variation in the transmission by the wireless transmission components of the switch assembly can be provided. In this embodiment, as well as the other embodiments herein wherein a SAW device is provided, the SAW device can be either a passive SAW device or an active SAW device. In the latter case, the SAW device is supplied with power from a power source on the vehicle, such as the vehicle's battery, a local battery or a local energy generator or harvester.

[0213] A variable impedance is used as the control mechanism for situations when variations in the operation of a

vehicular component are desired. For example, if a light is capable of being dimmed, then the variable impedance would be useful to control the dimming of the light. It is also useful to control adjustment of the volume of a sound system in the vehicle, as well as other analogue functions.

[0214] Referring now to FIG. 16F, another embodiment of the invention using a control mechanism, i.e., a switch or variable impedance, is an antenna 139 capable of reflecting an interrogating signal, and even which slightly modifies the interrogating signal (reflection from such an antenna being termed backscatter). The modification to the interrogating signal can be correlated to the desired manner for controlling the vehicular component. In this case, a lead is connected to an intermediate location on the antenna 139, e.g., the middle of the antenna 139, and a switch or variable impedance (a switch 129C is shown) is placed between the lead and ground. In the embodiment having a switch 129C, when the switch 129C is open, the antenna 139 will reflect at a particular frequency based on its length (for a simple dipole antenna). When the switch 129C is closed by the application of pressure to the exposed surface 138 of the passenger compartment, the antenna 139 will short and thereby effectively reduce the length of the antenna 139 and alter the resonant frequency of the antenna 139. A lead placed at the middle of the antenna 139 would, when connected to a closed switch 129C leading to ground, cause the resonant frequency to approximately double. In the embodiment having variable impedance, the antenna would be provided with a variable effect depending on the pressure exerted on the exposed surface or otherwise controlling the variable impedance.

[0215] Referring now to FIG. 16G, in another embodiment of a SAW sensor assembly in accordance with the invention, the circuit of the SAW sensor assembly has both an active mode and a passive mode depending on the presence of sufficient power in the energy storage device and whether the substrate to which the SAW sensor assembly is associated with is moving and thereby generates energy (for example, the energy may be generated using the power generating system described with reference to FIG. 9 herein and FIGS. 36, 36A and 98 of U.S. patent application Ser. No. 11/681,834 incorporated by reference herein). That is, the SAW sensor assembly circuit is provided with a passive mode, which is used when power is not provided to the SAW device 158 by either an energy harvester or energy generating system and the substrate (tire) is not moving, and an active mode when power is provided or available to the SAW device 158, e.g., provided by an energy harvester or energy generating system upon rotation of the tire or from an energy storage device. In the active mode (when the tire is rotating or there is sufficient power in the energy storage device to power the SAW device 158), a power detection circuit 157 detects power and closes a switch 129E thereby connecting the SAW device 158 to the antenna 119C. Power detection circuit 157 may be integrated into the SAW sensor assembly circuit so that whenever there is sufficient power being generated or available, the switch 129E is automatically closed. On the other hand, when energy for the SAW device 158 is not provided by an energy storage device and the tire is not rotating, switch 129E is open so as to avoid providing unnecessary signals from the SAW device 158 to the interrogator via the antenna 119C, the interrogator being used to obtain the signals from the SAW device 158 and process them into a meaningful reading of whatever prop-



erty or properties is/are being monitored by the SAW device **158**. However, since it is desirable to provide signals from the SAW device **158** for certain conditions of the property being monitored by the SAW device **158**, e.g., the property is below a threshold, a sensor **156** is provided and controls a second switch **129D** between the antenna **119C** and the SAW device **158**. Sensor **156** is designed to close the switch when one or more conditions relating to the property are satisfied to thereby enable a transmission from the antenna **119C** to the SAW device **158** and a modified signal to be provided from the SAW device **158** to the antenna **119C** for transmission to the interrogator.

[0216] For example, if sensor **156** is a pressure sensor and SAW assembly is being used to monitor tire pressure, then when the pressure is below a threshold as detected by sensor **156**, switch **129D** is closed and thereby allows the SAW device **158** to provide a modified signal. Sensor **156** should ideally be a sensor that does not require power (or requires minimal power) and can continually monitor the property, for example, a pressure sensing diaphragm could be used to and positioned relative to the switch **129D** so that when the pressure is below a threshold, the diaphragm moves and causes closure of the switch **129D**. Indeed, the switch **129D** could even be attached to such a pressure sensing diaphragm. In this case, when the pressure is at or above the threshold, the pressure sensing diaphragm does not close switch **129D** thereby conserving power. Switch **129D** would therefore be in an open position whenever the pressure was at or above the design threshold. Instead of a fixed threshold, a variable threshold can be used based on any number of factors. Also, a temperature sensor could be used to close a switch if temperature is being monitored, e.g., a diaphragm which expands with temperature could be attached to the switch **129D** or another thermal or temperature switch used in the circuit. Any other type of sensor which changes its state or condition and can cause closure of a switch based on a predetermined threshold, or switch which is activated based on a sensed property of the tire, could also be used in the invention.

[0217] The minimal transmission from the SAW device **158** is necessary in particular in a case where only one tire has a low pressure. One reason for this is because it is difficult to separate transmissions from more than one tire when operating in the passive mode.

[0218] Any of the disclosed applications can be interrogated by the central interrogator of this invention and can either be powered or operated powerlessly as described in general above. Block diagrams of three interrogators suitable for use in this invention are illustrated in FIGS. 19A-19C of the '834 application. FIG. 19A illustrates a super heterodyne circuit and FIG. 19B illustrates a dual super heterodyne circuit. FIG. 19C operates as follows. During the burst time two frequencies, F1 and F1+F2, are sent by the transmitter after being generated by mixing using oscillator Osc. The two frequencies are needed by the SAW transducer where they are mixed yielding F2 which is modulated by the SAW and contains the information. Frequency (F1+F2) is sent only during the burst time while frequency F1 remains on until the signal F2 returns from the SAW. This signal is used for mixing. The signal returned from the SAW transducer to the interrogator is F1+F2 where F2 has been

modulated by the SAW transducer. It is expected that the mixing operations will result in about 12 db loss in signal strength.

[0219] As discussed elsewhere herein, the particular tire that is sending a signal can be determined if multiple antennas, such as three, each receive the signal. For a 500 MHz signal, for example, the wave length is about 60 cm. If the distance from a tire transmitter to each of three antennas is on the order of one meter, then the relative distance from each antenna to the transmitter can be determined to within a few centimeters and thus the location of the transmitter can be found by triangulation. If that location is not a possible location for a tire transmitter, then the data can be ignored thus solving the problem of a transmitter from an adjacent vehicle being read by the wrong vehicle interrogator. This will be discussed below with regard to solving the problem of a truck having 18 tires that all need to be monitored. Note also, each antenna can have associated with it some simple circuitry that permits it to receive a signal, amplify it, change its frequency and retransmit it either through a wire or through the air to the interrogator thus eliminating the need for long and expensive coax cables.

[0220] U.S. Pat. No. 6,622,567 describes a peak strain RFID technology based device with the novelty being the use of a mechanical device that records the peak strain experienced by the device. Like the system of the invention herein, the system does not require a battery and receives its power from the RFID circuit. The invention described herein includes use of RFID-based sensors either in a peak strain mode or in a preferred continuous strain mode. This invention is not limited to measuring strain as SAW and RFID based sensors can be used for measuring many other parameters including chemical vapor concentration, temperature, acceleration, angular velocity etc.

[0221] One aspect of at least one of the inventions disclosed herein is the use of an interrogator to wirelessly interrogate multiple sensing devices thereby reducing the cost of the system since such sensors are in general inexpensive compared to the interrogator. The sensing devices are preferably based on SAW and/or RFID technologies although other technologies are applicable.

[0222] Antenna Considerations

[0223] Antennas are a very important aspect to SAW and RFID wireless devices such as can be used in tire monitors, seat monitors, weight sensors, child seat monitors, fluid level sensors and similar devices or sensors which monitor, detect, measure, determine or derive physical properties or characteristics of a component in or on the vehicle or of an area near the vehicle. In many cases, the location of a SAW or RFID device needs to be determined such as when a device is used to locate the position of a movable item in or on a vehicle such as a seat. In other cases, the particular device from a plurality of similar devices, such as a tire pressure and/or temperature monitor that is reporting, needs to be identified. Thus, a combination of antennas can be used and the time or arrival, angle of arrival, multipath signature or similar method used to identify the reporting device. One preferred method is derived from the theory of smart antennas whereby the signals from multiple antennas are combined to improve the signal-to-noise ratio of the incoming or outgoing signal in the presence of multipath effects, for example.

[0224] Additionally, since the signal level from a SAW or RFID device is frequently low, various techniques can be used to improve the signal-to-noise ratio as described below. Finally, at the frequencies frequently used such as 433 MHz, the antennas can become large and methods are needed to reduce their size. These and other antenna considerations that can be used to improve the operation of SAW, RFID and similar wireless devices are described below.

[0225] Tire Information Determination

[0226] One method of maintaining a single central antenna assembly while interrogating all four tires on a conventional automobile, is illustrated in FIGS. 17 and 18. The same technique may be used in the invention when interrogating multiple components, RFID devices or RFID-equipped objects as disclosed herein.

[0227] An additional antenna can be located near the spare tire, which is not shown. It should be noted that the system described below is equally applicable for vehicles with more than four tires such as trucks.

[0228] A vehicle body is illustrated as 620 having four tires 621 and a centrally mounted four element, switchable directional antenna array 622. The four beams are shown schematically as 623 with an inactivated beam as 624 and the activated beam as 625. The road surface 626 supports the vehicle. An electronic control circuit, not shown, which may reside inside the antenna array housing 622 or elsewhere, alternately switches each of the four antennas of the array 622 which then sequentially, or in some other pattern, send RF signals to each of the four tires 621 and wait for the response from the RFID, SAW or similar tire pressure, temperature, ID, acceleration and/or other property monitor arranged in connection with or associated with the tire 621. This represents a time domain multiple access system.

[0229] The interrogator makes sequential interrogation of wheels as follows:

[0230] Stage 1. Interrogator radiates 8 RF pulses via the first RF port directed to the 1st wheel.

[0231] Pulse duration is about 0.8  $\mu$ s.

[0232] Pulse repetition period is about 40  $\mu$ s.

[0233] Pulse amplitude is about 8 V (peak to peak)

[0234] Carrier frequency is about 426.00 MHz.

[0235] (Between adjacent pulses, the receiver opens its input and receives four-pulses echoes from the transponder located in the first wheel).

[0236] Then, during a time of about 8 ms, the internal micro controller processes and stores received data.

[0237] Total duration of this stage is 32  $\mu$ s+8 ms=8.032 ms.

[0238] Stage 2,3,4. Interrogator repeats operations as on stage 1 for 2<sup>nd</sup>, 3<sup>rd</sup> and 4<sup>th</sup> wheel sequentially via appropriate RF ports.

[0239] Stage 5. Interrogator stops radiating RF pulses and transfers data stored during stages 1-4 to the external PC for final processing and displaying. Then it returns to stage 1. The time interval for data transfer equals about 35 ms.

[0240] Some notes relative to FCC Regulations:

[0241] The total duration of interrogation cycle of four wheels is

$$8.032 \text{ ms} \times 4 + 35 \text{ ms} = 67.12 \text{ ms.}$$

[0242] During this time, interrogator radiates 8\*4=32 pulses, each of 0.8  $\mu$ s duration.

[0243] Thus, average period of pulse repetition is

$$67.12 \text{ ms} / 32 = 2.09 \text{ ms} = 2090 \mu\text{s}$$

[0244] Assuming that duration of the interrogation pulse is 0.8 s as mentioned, an average repetition rate is obtained

$$0.8 \mu\text{s} / 2090 \mu\text{s} = 0.38 \times 10^{-3}$$

[0245] Finally, the radiated pulse power is

$$P_p = (4 \text{ V})^2 / (2 \times 50 \text{ Ohm}) = 0.16 \text{ W}$$

and the average radiated power is

$$P_{ave} = 0.16 \times 0.38 \times 10^{-3} = 0.42 \times 10^{-3} \text{ W, or } 0.42 \text{ mW}$$

[0246] In another application, the antennas of the array 622 transmit the RF signals simultaneously and space the returns through the use of a delay line in the circuitry from each antenna so that each return is spaced in time in a known manner without requiring that the antennas be switched. Another method is to offset the antenna array, as illustrated in FIG. 20, so that the returns naturally are spaced in time due to the different distances from the tires 621 to the antennas of the array 622. In this case, each signal will return with a different phase and can be separated by this difference in phase using methods known to those in the art.

[0247] In another application, not shown, two wide angle antennas can be used such that each receives any four signals but each antenna receives each signal at a slightly different time and different amplitude permitting each signal to be separated by looking at the return from both antennas since, each signal will be received differently based on its angle of arrival.

[0248] Additionally, each SAW or RFID device can be designed to operate on a slightly different frequency and the antennas of the array 622 can be designed to send a chirp signal and the returned signals will then be separated in frequency, permitting the four signals to be separated. Alternately, the four antennas of the array 622 can each transmit an identification signal to permit separation. This identification can be a numerical number or the length of the SAW substrate, for example, can be random so that each property monitor has a slightly different delay built in which permits signal separation. The identification number can be easily achieved in RFID systems and, with some difficulty and added expense, in SAW systems. Other methods of separating the signals from each of the tires 621 will now be apparent to those skilled in the art. One preferred method in particular will be discussed below and makes use of an RFID switch.

[0249] There are two parameters of SAW system, which has led to the choice of a four echo pulse system:

[0250] ITU frequency rules require that the radiated spectrum width be reduced to:  $\Delta\phi \leq 1.75 \text{ MHz}$  (in ISM band,  $F=433.92 \text{ MHz}$ );

[0251] The range of temperature measurement should be from -40 F up to +260 F.

[0252] Therefore, burst (request) pulse duration should be not less than 0.6 microseconds.

$$\tau_{bur.}=1/\Delta\phi\geq 0.6 \mu s$$

[0253] This burst pulse travels to a SAW sensor and then it is returned by the SAW to the interrogator. The sensor's antenna, interdigital transducer (IDT), reflector and the interrogator are subsystems with a restricted frequency pass band. Therefore, an efficient pass band of all the subsystems  $H(f)_{\Sigma}$  will be defined as product of the partial frequency characteristic of all components:

$$H(f)_{\Sigma}=H(f)_1 * H(f)_2 * \dots * H(f)_i$$

[0254] On the other hand, the frequency  $H(\phi)_{\Sigma}$  and a time  $I(\tau)_{\Sigma}$  response of any system are interlinked to each other by Fourier's transform. Therefore, the shape and duration ( $\tau_{echo}$  puls) an echo signal on input to the quadrature demodulator will differ from an interrogation pulse.

[0255] In other words, duration an echo signal on input to the quadrature demodulator is defined as mathematical convolution of a burst signal  $t_{bur.}$  and the total impulse response of the system  $I(\tau)_{\Sigma}$ .

$$\tau_{echo}=\tau_{bur.} \otimes I(\tau)_{\Sigma}$$

[0256] The task is to determine maximum pulse duration on input to the quadrature demodulator  $\tau_{echo}$  under a burst pulse duration  $\tau_{bur.}$  of 0.6 microseconds. It is necessary to consider in time all echo signals.

[0257] In addition, it is necessary to take into account the following:

[0258] each subsequent echo signal should not begin earlier than the completion of the previous echo pulse. Otherwise, the signals will interfere with each other, and measurement will not be correct;

[0259] for normal operation of available microcircuits, it is necessary that the signal has a flat apex with a duration not less than 0.25 microseconds ( $\tau_{meg}=t3-t2$ ). The signal's phase will be constant only on this segment;

[0260] the total sensor's pass band (considering double transit IDT and its antenna as a reflector) constitutes 10 MHz;

[0261] the total pass band of the interrogator constitutes no more than 4 MHz.

[0262] Conducting the corresponding calculations yields the determination that duration of impulse front ( $t2-t1=t4-t3$ ) constitutes about 0.35 microseconds. Therefore, total duration of one echo pulse is not less than:

$$\tau_{echo.}=(t2-t1)+\tau_{meg.}+(t4-t3)=0.35+0.25+0.35=0.95 \mu s$$

[0263] Hence, the arrival time of each following echo pulse should be not earlier than 1.0 microsecond. This conclusion is very important.

[0264] In Appendix 1 of the '139 application, it is shown that for correct temperature measuring in the required band it is necessary to meet the following conditions:

$$\frac{(T2-T1)}{C.}) * 434.92 * 10^{-6} = \frac{1}{K.} * (125^{\circ} C. - (-40^{\circ} C.))$$

[0265] This condition is outrageous. If to execute ITU frequency rules, the band of correct temperature measuring will be reduced five times:

$$(125^{\circ} C. - (-40^{\circ} C.)) * 194 \text{ ns} / 1000 \text{ ns} = 32^{\circ} C. = 58^{\circ} F.$$

[0266] This is the main reason that it is necessary to add the fourth echo pulse in a sensor. The principle purpose of the fourth echo pulse is to make the temperature measurement unambiguous in a wide interval of temperatures when a longer interrogation pulse is used (the respective time intervals between the sensor's echo pulses are also longer). A mathematical model of the processing of a four-pulse echo that explains these statements is presented in Appendix 3 of the '139 application.

[0267] The duration of the interrogation pulse and the time positions of the four pulses are calculated as:

$$\begin{aligned} T1 &> 4 * \tau_{echo} = 4.00 \mu s \\ T2 &= T1 + \tau_{echo} = 5.00 \mu s \\ T3 &= T2 + \tau_{echo} = 6.00 \mu s \\ T4 &= T3 + \tau_{echo} + 0.08 \mu s = 7.08 \mu s \end{aligned}$$

[0268] The sensor's design with four pulses is exhibited in FIGS. 25 and 26 of the '834 application.

$\tau_{bur}$	0.60 $\mu s$
T1	4.00 $\mu s$
T2	5.00 $\mu s$
T3	6.00 $\mu s$
T4	7.08 $\mu s$

[0269] The reason that such a design was selected is that this design provides three important conditions:

[0270] 1. It has the minimum RF signal propagation loss. Both SAW waves use for measuring (which are propagated to the left and to the right from IDT).

[0271] 2. All parasitic echo signals (signals of multiple transits) are eliminated after the fourth pulse. For example, the pulse is excited by the IDT, then it is reflected from a reflector No1 and returns to the IDT. The pulse for the second time is re-emitted and it passes the second time on the same trajectory. The total time delay will be 8.0 microseconds in this case.

[0272] 3. It has the minimum length.

[0273] Although the discussion herein concerns the determination of tire information, the same system can be used to determine the location of seats, the location of child seats when equipped with sensors, information about the presence of object or chemicals in vehicular compartments and the like.

[0274] Smart Antennas

[0275] Some of the shortcomings in today's wireless products can be overcome by using smart antenna technology. A smart antenna is a multi-element antenna that significantly improves reception by intelligently combining the signals received at each antenna element and adjusting the antenna characteristics to optimize performance as the transmitter or receiver moves and the environment changes.

[0276] Smart antennas can suppress interfering signals, combat signal fading and increase signal range thereby increasing the performance and capacity of wireless systems.

[0277] A method of separating signals from multiple tires, for example, is to use a smart antenna such as that manu-

factured by Motia. This particular Motia device is designed to operate at 433 MHz and to mitigate multipath signals at that frequency. The signals returning to the antennas from tires, for example, contain some multipath effects that, especially if the antennas are offset somewhat from the vehicle center, are different for each wheel. Since the adaptive formula will differ for each wheel, the signals can be separated (see “enhancing 802.11 WLANs through Smart Antennas”, January 2004 available at motia.com). The following is taken from that paper.

[0278] “Antenna arrays can provide gain, combat multipath fading, and suppress interfering signals, thereby increasing both the performance and capacity of wireless systems. Smart antennas have been implemented in a wide variety of wireless systems, where they have been demonstrated to provide a large performance improvement. However, the various types of spatial processing techniques have different advantages and disadvantages in each type of system.”

[0279] “This strategy permits the seamless integration of smart antenna technology with today’s legacy WLAN chipset architecture. Since the 802.11 system uses time division duplexing (the same frequency is used for transmit and receive), smart antennas can be used for both transmit and receive, providing a gain on both uplink and downlink, using smart antennas on either the client or access point alone. Results show a 13 dB gain with a four element smart antenna over a single antenna system with the smart antenna on one side only, and an 18 dB gain with the smart antenna on both the client and access point. Thus, this “plug-and-play” adaptive array technology can provide greater range, average data rate increases per user, and better overall coverage.

[0280] “In the multibeam or phased array antenna, a beamformer forms several narrow beams, and a beam selector chooses the beam for reception that has the largest signal power. In the adaptive array, the signal is received by several antenna elements, each with similar antenna patterns, and the received signals are weighted and combined to form the output signal. The multibeam antenna is simpler to implement as the beamformer is fixed, with the beam selection only needed every few seconds for user movement, while the adaptive array must calculate the complex beamforming weights at least an order of magnitude faster than the fading rate, which can be several Hertz for pedestrian users.”

[0281] “Finally, there is pattern diversity, the use of antenna elements with different patterns. The combination of these types of diversity permits the use of a large number of antennas even in a small form factor, such as a PCMCIA card or handset, with near ideal performance.”

[0282] Through its adaptive beamforming technology, Motia has developed cost-effective smart antenna appliques that vastly improve wireless performance in a wide variety of wireless applications including Wi-Fi that can be incorporated into wireless systems without major modifications to existing products. Although the Motia chipset has been applied to several communication applications, it has yet to be applied to all of the monitoring applications as disclosed in the current assignee’s patents and pending patent applications, and in particular vehicular monitoring applications such as tire monitoring.

[0283] The smart antenna works by determining a set of factors or weights that are used to operate on the magnitude

and/or phase of the signals from each antenna before the signals are combined. However, since the geometry of a vehicle tire relative to the centralized antenna array does not change much as the tire rotates, but is different for each wheel, the weights themselves contain the information as to which tire signal is being received. In fact, the weights can be chosen to optimize signal transmission from a particular tire thus providing a method of selectively interrogating each tire at the maximum antenna gain.

[0284] Distributed Load Monopole

[0285] Antenna developments in the physics department at the University of Rhode Island have resulted in a new antenna technology. The antennas developed called DLM’s (Distributed loaded monopole) are small efficient, wide bandwidth antennas. The simple design exhibits 50-ohm impedance and is easy to implement. They require only a direct feed from a coax cable and require no elaborate matching networks.

[0286] The prime advantage to this technology is a substantial reduction of the size of an antenna. Typically, the DLM antenna is about  $\frac{1}{3}$  the size of a normal dipole with only minor loss in efficiency. This is especially important for vehicle applications where space is always at a premium. Such antennas can be used for a variety of vehicle radar and communication applications as well for the monitoring of RFID, SAW and similar devices on a vehicle and especially for tire pressure, temperature, and/or acceleration monitoring as well as other monitoring purposes. Such applications have not previously been disclosed.

[0287] Although the DLM is being applied to several communication applications, it has yet to be applied to all of the monitoring applications as disclosed in the current assignee’s patents and pending patent applications. The antenna gain that results and the ability to pack several antennas into a small package are attractive features of this technology.

[0288] Plasma Antenna

[0289] The following disclosure was taken from “Markland Technologies—Gas Plasma”: ([www.marklandtech.com](http://www.marklandtech.com))

[0290] “Plasma antenna technology employs ionized gas enclosed in a tube (or other enclosure) as the conducting element of an antenna. This is a fundamental change from traditional antenna design that generally employs solid metal wires as the conducting element. Ionized gas is an efficient conducting element with a number of important advantages. Since the gas is ionized only for the time of transmission or reception, “ringing” and associated effects of solid wire antenna design are eliminated. The design allows for extremely short pulses, important to many forms of digital communication and radars. The design further provides the opportunity to construct an antenna that can be compact and dynamically reconfigured for frequency, direction, bandwidth, gain and beamwidth. Plasma antenna technology will enable antennas to be designed that are efficient, low in weight and smaller in size than traditional solid wire antennas.”

[0291] “When gas is electrically charged, or ionized to a plasma state it becomes conductive, allowing radio frequency (RF) signals to be transmitted or received. We

employ ionized gas enclosed in a tube as the conducting element of an antenna. When the gas is not ionized, the antenna element ceases to exist. This is a fundamental change from traditional antenna design that generally employs solid metal wires as the conducting element. We believe our plasma antenna offers numerous advantages including stealth for military applications and higher digital performance in commercial applications. We also believe our technology can compete in many metal antenna applications.”

[0292] “Initial studies have concluded that a plasma antenna’s performance is equal to a copper wire antenna in every respect. Plasma antennas can be used for any transmission and/or modulation technique: continuous wave (CW), phase modulation, impulse, AM, FM, chirp, spread spectrum or other digital techniques. And the plasma antenna can be used over a large frequency range up to 20 GHz and employ a wide variety of gases (for example neon, argon, helium, krypton, mercury vapor and xenon). The same is true as to its value as a receive antenna.”

[0293] “Plasma antenna technology has the following additional attributes:

[0294] No antenna ringing provides an improved signal to noise ratio and reduces multipath signal distortion.

[0295] Reduced radar cross section provides stealth due to the non-metallic elements.

[0296] Changes in the ion density can result in instantaneous changes in bandwidth over wide dynamic ranges.

[0297] After the gas is ionized, the plasma antenna has virtually no noise floor.

[0298] While in operation, a plasma antenna with a low ionization level can be decoupled from an adjacent high-frequency transmitter.

[0299] A circular scan can be performed electronically with no moving parts at a higher speed than traditional mechanical antenna structures.

[0300] It has been mathematically illustrated that by selecting the gases and changing ion density that the electrical aperture (or apparent footprint) of a plasma antenna can be made to perform on par with a metal counterpart having a larger physical size.

[0301] Our plasma antenna can transmit and receive from the same aperture provided the frequencies are widely separated.

[0302] Plasma resonance, impedance and electron charge density are all dynamically reconfigurable. Ionized gas antenna elements can be constructed and configured into an array that is dynamically reconfigurable for frequency, beamwidth, power, gain, polarization and directionality—on the fly.

[0303] A single dynamic antenna structure can use time multiplexing so that many RF subsystems can share one antenna resource reducing the number and size of antenna structures.”

[0304] Several of the characteristics discussed above are of particular usefulness for several of the inventions herein including the absence of ringing, the ability to turn the

antenna off after transmission and then immediately back on for reception, the ability to send very short pulses, the ability to alter the directionality of the antenna and to sweep thereby allowing one antenna to service multiple devices such as tires and to know which tire is responding. Additional advantages include, smaller size, the ability to work with chirp, spread spectrum and other digital technologies, improved signal to noise ratio, wide dynamic range, circular scanning without moving parts, and antenna sharing over differing frequencies, among others.

[0305] Some of the applications disclosed herein can use ultra wideband transceivers. UWB transceivers radiate most of the energy with its frequency centered on the physical length of the antenna. With the UWB connected to a plasma antenna, the center frequency of the UWB transceiver could be hopped or swept simultaneously.

[0306] A plasma antenna can solve the problem of multiple antennas by changing its electrical characteristic to match the function required—Time domain multiplexed. It can be used for high-gain antennas such as phase array, parabolic focus steering, log periodic, yogi, patch quadrifiler, etc. One antenna can be used for GPS, ad-hoc (such as car-to-car) communication, collision avoidance, back up sensing, cruise control, radar, toll identification and data communications.

[0307] Although the plasma antennas are being applied to several communication applications, they have yet to be applied to the monitoring applications as disclosed herein. The many advantages that result and the ability to pack several antenna functions into a small package are attractive features of this technology. Patents and applications that discuss plasma antennas include: U.S. Pat. No. 6,710,746 and U.S. Pat. App. Pub Nos. 20030160742 and 20040130497.

[0308] Dielectric Antenna

[0309] A great deal of work is underway to make antennas from dielectric materials. In one case, the electric field that impinges on the dielectric is used to modulate a transverse electric light beam. In another case, the reduction of the speed of electro magnetic waves due to the dielectric constant is used to reduce the size of the antenna. It can be expected that developments in this area will affect the antennas used in cell phones as well as in RFID and SAW-based communication devices in the future. Thus, dielectric antennas can be advantageously used with some of the inventions disclosed herein.

Nanotube Antenna

[0310] Antennas made from carbon nanotubes are beginning to show promise of increasing the sensitivity of antennas and thus increasing the range for communication devices based on RFID, SAW or similar devices where the signal strength frequently limits the range of such devices. The use of these antennas is therefore contemplated herein for use in tire monitors and the other applications disclosed herein.

[0311] Combinations of the above antenna designs in many cases can benefit from the advantages of each type to add further improvements to the field. Thus the inventions herein are not limited to any one of the above concepts nor is it limited to their use alone. Where feasible, all combinations are contemplated herein.

[0312] Antenna Summary

[0313] A general system for obtaining information about a vehicle or a component thereof or therein is illustrated in FIG. 19 and includes multiple sensors 627 which may be arranged at specific locations on the vehicle, on specific components of the vehicle, on objects temporarily placed in the vehicle such as child seats, or on or in any other object in or on the vehicle or in its vicinity about which information is desired. The sensors 627 may be SAW or RFID sensors or other sensors which generate a return signal upon the detection of a transmitted radio frequency signal. A multi-element antenna array 622 is mounted on the vehicle, in either a central location as shown in FIG. 17 or in an offset location as shown in FIG. 20, to provide the radio frequency signals which cause the sensors 627 to generate the return signals.

[0314] A control system 628 is coupled to the antenna array 622 and controls the antennas in the array 622 to be operative as necessary to enable reception of return signals from the sensors 627. There are several ways for the control system 628 to control the array 622, including to cause the antennas to be alternately switched on in order to sequentially transmit the RF signals therefrom and receive the return signals from the sensors 627 and to cause the antennas to transmit the RF signals simultaneously and space the return signals from the sensors 627 via a delay line in circuitry from each antennas such that each return signal is spaced in time in a known manner without requiring switching of the antennas. The control system can also be used to control a smart antenna array.

[0315] The control system 628 also processes the return signals to provide information about the vehicle or the component. The processing of the return signals can be any known processing including the use of pattern recognition techniques, neural networks, fuzzy systems and the like.

[0316] The antenna array 622 and control system 628 can be housed in a common antenna array housing 630.

[0317] Once the information about the vehicle or the component is known, it is directed to a display/telematics/adjustment unit 629 where the information can be displayed on a display 629 to the driver, sent to a remote location for analysis via a telematics unit 629 and/or used to control or adjust a component on, in or near the vehicle. Although several of the figures illustrate applications of these technologies to tire monitoring, it is intended that the principles and devices disclosed can be applied to the monitoring of a wide variety of components on and off a vehicle.

[0318] In summary, the use of devices capable of reading or scanning RFID devices when situated in compartments or spaces defined by vehicles or other mobile assets provides significant advantages. Among other things, it allows for the determination of the identification and location of the RFID devices and thus objects equipped with such RFID devices, and with a communications or telematics unit coupled to the interrogator, it allows for communication of that information off of the vehicle, i.e., to one or more remote sites. The overall system identifies the RFID device if it generates a unique identification code, which is usually the case, and thus can generate a transmission to the remote site containing an identification of an object in a space of a mobile asset.

[0319] With the foregoing system, it is possible at the remote site to locate and monitor the RFID-equipped object.

[0320] Alternative or in addition to the communication to a remote site, the interrogator could also transmit or otherwise provide the signal with an identification of the object to another system on the vehicle itself. In this manner, someone looking for an RFID-equipped object in a space could easily determine its location, such as a package delivery driver looking for a specific package in a truck or an airline worker looking for a specific passenger's luggage.

[0321] Although several preferred embodiments are illustrated and described above, there are possible combinations using other geometries, sensors, materials and different dimensions for the components that perform the same functions. At least one of the inventions disclosed herein is not limited to the above embodiments and should be determined by the following claims. There are also numerous additional applications in addition to those described above. Many changes, modifications, variations and other uses and applications of the subject invention will, however, become apparent to those skilled in the art after considering this specification and the accompanying drawings which disclose the preferred embodiments thereof. All such changes, modifications, variations and other uses and applications which do not depart from the spirit and scope of the invention are deemed to be covered by the invention which is limited only by the following claims.

1. A method for obtaining information about an object on which a radio-frequency identification (RFID) device is mounted when the RFID device is in a space defined by a frame, comprising:

arranging a plurality of antennas on the frame to enable transmission of signals into the space and reception of signals from the space;

controlling transmission of radio frequency signals by the antennas by means of at least one interrogator;

directing radio frequency signals from at least one of the antennas, controlled by the at least one interrogator, into the space to cause a RFID device in the space, when present, to return a signal if and when it receives any signal from any of the antennas;

receiving any return signals from the RFID device; and

deriving information about the object on which the RFID device is mounted based on the return signals, the information being a location of the object, motion of the object and/or identification of the object.

2. The method of claim 1, further comprising:

arranging a communications device on the frame;

coupling the communications device to each of the at least one interrogator; and

transmitting the information about the device to a remote site using the communications device.

3. The method of claim 1, wherein the frame is interposed between the at least one interrogator and the space, further comprising arranging at least one RF window on the frame to enable passage of signals between the at least one interrogator and the space.

4. The method of claim 1, wherein each of the at least one interrogator is separate and apart from the frame, further comprising:

coupling the antennas to an antenna multiplexer;

coupling the antenna multiplexer to an external antenna extending outside of the frame and which communicates with the at least one interrogator; and

controlling transmission and reception of signals by the antennas via the multiplexer.

5. The method of claim 4, further comprising associating each of the antennas with a defined portion of the space, the step of deriving information about the RFID device or object to which the RFID device is attached comprising determining the location of the RFID device by analyzing strength of return signals to all of the antennas to determine which antenna provides the largest return signal whereby the RFID device is considered to be located in that portion of the space associated with the antenna which provides the largest return signal.

6. The method of claim 5, further comprising partitioning the space into a plurality of discrete longitudinal portions, each antenna being associated with only a single one of the portions.

7. The method of claim 1, further comprising:

arranging an electricity-generating system on the frame; and

coupling the electricity-generating system to the at least one interrogator and antennas to provide electricity for operation thereof.

8. The method of claim 1, further comprising:

providing the at least one interrogator and the RFID device with a clock;

arranging the RFID device to synchronize its clock upon reception of any signal from any of the antennas relative to the at least one interrogator's clock; and

arranging the RFID device to return the signal if it receives any signal from any of the antennas only after synchronization of its clock to the at least one interrogator's clock; and

arranging the interrogator to predict a transmit time at which the RFID device will return a signal after reception of a signal from one of the antennas whose transmission is controlled by the at least one interrogator;

the step of deriving information about the RFID device or the object to which the RFID device is attached comprising analyzing an arrival time of the return signal from the RFID device and the predicted transmit time to enable a measurement of a distance between the RFID device and the antenna to be determined.

9. The method of claim 8, wherein the step of arranging the RFID device to return the signal only after synchronization of its clock to the interrogator's clock comprises arranging the RFID device to return the signal at a specific time relative to the reception of the signal from the antenna, at a specific time relative to a time when the signal from the antenna was sent or at a predesignated time.

10. The method of claim 1, wherein the step of directing radio frequency signals from at least one of the antennas into

the space comprises directing radio frequency signals from a plurality of antennas into the space, further comprising arranging the RFID device to provide information in the return signal indicative of a phase or relative time of reception of signals from multiple antennas.

11. An asset with an integral system for obtaining information about a radio-frequency identification (RFID) device or an object on which the RFID device is mounted when the RFID device or object is in or in connection with the asset, comprising:

a frame defining an interior space of the asset;

a plurality of antennas arranged on said frame and enabling transmission of radio frequency signals into the space and reception of signals from the space;

an interrogator coupled to said antennas and arranged to control transmission of signals by said antennas whereby when a RFID device in the space receives a transmitted signal, it generates a return signal, said antennas being arranged to receive the return signals generated by any RFID devices in the space; and

a processor coupled to said antennas and said interrogator for receiving and analyzing the return signals received by said antennas to derive information about the RFID device or object on which the RFID device is mounted based on the return signals.

12. The asset of claim 11, wherein said antennas comprise at least three antennas and said processor is arranged to determine a location of the RFID device based on measurements of a distance between each of said antennas and the RFID device.

13. The asset of claim 11, further comprising a communications device arranged on said frame and coupled to said interrogator, said communications device being arranged to transmit the information about the RFID device obtained by said processor a remote site.

14. The asset of claim 11, wherein said frame is interposed between said interrogator and the space, said frame including at least one RF window which enables passage of signals between said interrogator and the space.

15. The asset of claim 11, wherein said frame is interposed between said interrogator and said space, further comprising:

an antenna multiplexer coupled to said antennas; and

an external antenna coupled to said antenna multiplexer and extending outside of said frame and communicating with said interrogator, transmission and reception of signals by said antennas being effected through said multiplexer.

16. The asset of claim 11, wherein each of said antennas are spaced from one another along one dimension of said frame, said processor being arranged to determine the location of the RFID device by analyzing strength of return signals to all of said antennas to determine which of said antennas provides the largest return signal whereby the RFID device is considered to be located in a portion of the space associated with said antenna which provides the largest return signal.

17. The asset of claim 11, further comprising an electricity-generating system arranged on said frame and coupled to said interrogator and said antennas to provide electricity for operation thereof.

**18.** The asset of claim 11, wherein said interrogator has a clock and the RFID device has a clock, the RFID device being arranged to synchronize its clock upon reception of any signal from any of said antennas relative to said clock of said interrogator and return the signal if it receives any signal from any of said antennas only after synchronization of its clock to said clock of said interrogator, said processor being arranged to predict a transmit time at which the RFID device will return a signal after reception of a signal from one of said antennas whose transmission is controlled by said interrogator and analyze an arrival time of the return signal from the RFID device with the predicted transmit time to enable a measurement of a distance between the RFID device and said antenna to be determined.

**19.** A monitoring system for monitoring objects in an asset, comprising:

- a frame defining an interior space of the asset;
- a plurality of antennas arranged on said frame and enabling transmission of radio frequency signals into the space and reception of signals from the space;
- a radio-frequency identification (RFID) device arranged in connection with each object to be monitored;
- at least one interrogator coupled to said antennas and arranged to control transmission of signals by said antennas whereby when one of said RFID devices present in the space receives a transmitted signal from

said at least one interrogator, it generates a return signal, said antennas being arranged to receive the return signals generated by any of said RFID devices in the space; and

- a processor coupled to said antennas and said at least one interrogator for coordinating transmission of signals by said antennas under control of said at least one interrogator, and for receiving and analyzing the return signals received by said antennas to derive information about said RFID device or object on which said RFID device is mounted based on the return signals.

**20.** The system of claim 19, wherein said interrogator has a clock and each of said RFID devices has a clock and is arranged to synchronize its clock upon reception of any signal from any of said antennas relative to said clock of said interrogator and return the signal if it receives any signal from any of said antennas only after synchronization of its clock to said clock of said interrogator, said processor being arranged to predict a transmit time at which each of said RFID devices will return a signal after reception of a signal whose transmission is controlled by said interrogator and analyze an arrival time of the return signal from any of said RFID devices with the predicted transmit time to enable a measurement of a distance between said RFID device and said interrogator to be determined.

\* \* \* \* \*