



(12) **EUROPEAN PATENT APPLICATION**

(43) Date of publication:  
**15.11.2000 Bulletin 2000/46**

(51) Int Cl.7: **E21B 10/56**

(21) Application number: **00303645.6**

(22) Date of filing: **28.04.2000**

(84) Designated Contracting States:  
**AT BE CH CY DE DK ES FI FR GB GR IE IT LI LU  
MC NL PT SE**  
Designated Extension States:  
**AL LT LV MK RO SI**

(72) Inventors:  
• **Griffin, Nigel Dennis**  
**Whitminster, Gloucestershire GL2 7PS (GB)**  
• **Watson, Dean Travers**  
**Leckhampton, Cheltenham GL50 2HA (GB)**

(30) Priority: **14.05.1999 GB 9911139**

(74) Representative: **Bailey, Richard Alan**  
**A.R. Davies & Co.,**  
**27 Imperial Square**  
**Cheltenham, Gloucestershire GL50 1RQ (GB)**

(71) Applicant: **Camco International (UK) Limited**  
**Stonehouse, Gloucestershire GL10 3RQ (GB)**

(54) **Preform cutting elements for rotary drill bits**

(57) A preform cutting element, for a rotary drag-type drill bit, includes a facing table 10 of superhard material having a front face and a rear surface bonded to the front surface of a substrate 12 which is less hard than the superhard material, the cutting element having a peripheral surface which includes at least one cutting

apex 18 defined between two adjacent regions of the peripheral surface which are disposed at an angle to one another, and the rear surface of the facing table 10 being formed with at least one protuberance 20 which projects into a correspondingly shaped recess in the substrate 12.

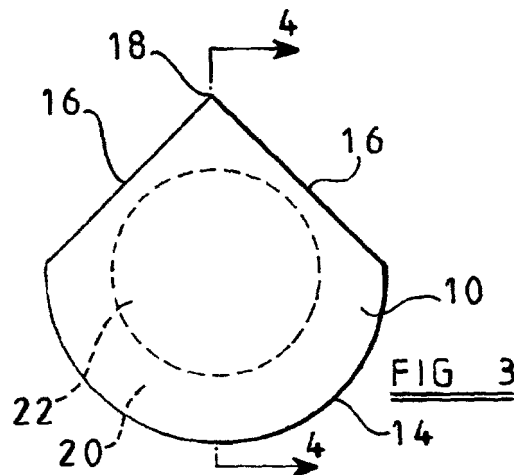

## Description

**[0001]** The invention relates to preform cutting elements for rotary drag-type drill bits, and of the kind comprising a facing table of superhard material having a front face and a rear surface bonded to the front surface of a substrate which is less hard than the superhard material.

**[0002]** Such preform cutting elements usually have a facing table of polycrystalline diamond, although other superhard materials are available, such as cubic boron nitride. The substrate of less hard material is often formed from cemented tungsten carbide, and the facing table and substrate are bonded together during formation of the element in a high pressure, high temperature forming press. This forming process is well known and will not be described in detail.

**[0003]** Each preform cutting element may be mounted on a carrier in the form of a generally cylindrical stud or post received in a pocket in the body of the drill bit. The carrier is often also formed from cemented tungsten carbide, the surface of the substrate being brazed to a surface on the carrier. Alternatively, the substrate itself may be of sufficient thickness as to provide, in effect, a cylindrical stud which is sufficiently long to be directly received in a pocket in the bit body, without being first brazed to a carrier. As is well known, the body of the drill bit itself may be machined from metal, usually steel, or may be moulded using a powder metallurgy process.

**[0004]** Cutting elements of the above-described kind are often in the form of circular or part-circular tablets. Each cutter is so mounted on the bit body that a portion of its periphery defines a cutting edge which acts on the surface of the formation being drilled. In the case of a circular cutter the cutting edge will be provided by a curved stretch of the circular periphery of the cutter. In some locations on the drill bit, such as in the gauge region of the bit, however, the cutting element will be formed with a straight cutting edge across part of its periphery to act on the formation.

**[0005]** When drilling some types of formation, however, for example chalk or limestone, it may be more effective and efficient for the cutting elements to act on the formation with more of a "scribing" action. For this purpose the cutting element is shaped so that a part of its periphery is "pointed", i.e. is formed with a cutting apex defined between two adjacent regions of the peripheral surface which are disposed at an angle to one another. The cutting element may comprise a single cutting apex, or a plurality of cutting apices disposed side by side on its periphery.

**[0006]** Although cutters of this configuration may cut some formations more effectively, they tend to suffer from accelerated wear and also from impact damage as a result of abrasive and impact forces being concentrated on a comparatively small area of the periphery of the cutting element. The present invention sets out to provide an improved preform cutting element of this type

where this disadvantage may be reduced or overcome.

**[0007]** According to the invention there is provided a preform cutting element, for a rotary drag-type drill bit, including a facing table of superhard material having a front face and a rear surface bonded to the front surface of a substrate which is less hard than the superhard material, the cutting element having a peripheral surface which includes at least one cutting apex defined between two adjacent regions of the peripheral surface which are disposed at an angle to one another, and the rear surface of the facing table being formed with at least one protuberance which projects into a correspondingly shaped recess in the substrate.

**[0008]** Preferably, at least part of said protuberance on the facing table is located adjacent said cutting apex. More preferably, at least a part of the protuberance forms part of the periphery of the cutting element at said cutting apex.

**[0009]** The protuberance of superhard material projecting from the facing table into the substrate serves to strengthen the element and, in the case where it is located adjacent the cutting apex, it serves to reduce the rate of wear of the cutting apex and also to protect it against impact damage.

**[0010]** Preferably, the rear surface of the facing table and the front surface of the substrate of the cutting element are co-extensive, although this is not essential, and arrangements are possible where the facing table extends over only a part of the front surface of the substrate.

**[0011]** Said protuberance may comprise a thickened rim extending around at least a part of the periphery of the facing table and projecting into a correspondingly shaped recess which extends around at least a part of the periphery of the substrate.

**[0012]** In one arrangement, the thickened rim may extend substantially continuously around the whole periphery of the facing table. In this case, the outer surface of the thickened rim may form part of the whole periphery of the cutting element. The region of the rear surface of the facing table within the thickened rim may be circular.

**[0013]** In another arrangement according to the invention, the thickened rim may comprise two or more rim portions spaced apart around the periphery of the cutting element, at least one portion of the rim forming part of the periphery of the cutting element at said cutting apex. In this case also, the region of the rear surface of the facing table within the thickened rim portions may be circular.

**[0014]** In a further embodiment the protuberance may be generally triangular in configuration, comprising an inner surface bonded to the substrate and two outer surfaces defining part of the outer periphery of the cutting element on either side of the cutting apex.

**[0015]** In this case the inner surface of the protuberance may be flat, concave, convex or of any other shape. The protuberance may reduce in cross-section

as it extends away from the rear surface of the facing table. For example, the inner surface of the protuberance may be inclined or stepped.

**[0016]** In a further embodiment the protuberance on the rear surface of the facing table may form part of the periphery of the cutting element at said cutting apex, and may extend inwardly away from the cutting apex into the interior of the substrate. For example, the protuberance may extend across the full width of the cutting element so as also to form part of the periphery of the cutting element in a region thereof opposite said cutting apex. In either case the protuberance may have substantially parallel side surfaces bonded to the sides of a recess in the front surface of the substrate.

**[0017]** In any of the above arrangements, the cutting element may be formed with a plurality of cutting apices spaced apart around the periphery thereof. The part of the periphery between two adjacent cutting apices may be smoothly concave or angular. Preferably, where there are a plurality of cutting apices, imaginary lines bisecting the cutting apices are substantially parallel so that the cutting apices point in generally the same direction.

**[0018]** In any of the above arrangements the periphery of the cutting element may be part-circular. In this case one or both regions of the periphery on either side of a cutting apex may extend generally tangentially to a part-circular portion of the periphery of the cutting element.

**[0019]** The invention also provides a preform cutting element, for a rotary drag-type drill bit, including a facing table of superhard material having a front face and a rear surface bonded to the front surface of a substrate which is less hard than the superhard material, the cutting element having a peripheral surface which includes at least one cutting apex defined between two adjacent regions of the peripheral surface which are disposed at an angle to one another, and the facing table including at least one portion which is of greater abrasion resistance than other portions of the facing table and is located adjacent said cutting apex. Preferably, at least a part of the portion of greater abrasion resistance forms part of the periphery of the cutting element at said cutting apex.

**[0020]** This aspect of the invention may be used alone or in combination with the first mentioned aspect of the invention where the rear surface of the facing table is formed with at least one protuberance which projects into a correspondingly shaped recess in the substrate.

**[0021]** The following is a more detailed description of embodiments of the invention, by way of example, reference being made to the accompanying drawings in which:

Figure 1 is a diagrammatic side elevation of one form of rotary drag-type drill bit of a kind with which the preform cutting elements of the present invention may be used,

Figure 2 is an end view of the bit shown in Figure 1, Figure 3 is a top view of one form of preform cutting element for a drag-type drill bit, in accordance with the present invention,

Figure 4 is a section on the Line 4-4 of Figure 1, Figures 5-22 are similar views showing alternative forms of preform cutting element in accordance with the invention,

Figures 23 and 24 are diagrammatic perspective views of the substrates of two further forms of preform cutting element,

Figure 25 is a top view of a further form of preform cutting element,

Figure 26 is a side elevation of the cutting element shown in Figure 25,

Figure 27 is a top view of a further form of preform cutting element,

Figure 28 is a side elevation of the cutting element shown in Figure 26,

Figures 29-32 are diagrammatic perspective views of further forms of preform cutting element in accordance with the invention,

Figures 33-48 are top and sectional views of still further forms of preform cutting element in accordance with the invention, and

Figures 49 and 50 are side elevation and top views of a cutting element in accordance with another embodiment of the invention.

**[0022]** One typical and well known form of drag-type drill bit is shown in Figures 1 and 2 and comprises a bit body 1 on the leading surface of which are formed six circumferentially spaced upstanding blades 2 which extend outwardly away from the axis of rotation of the bit. A number of preform cutting elements 3 are spaced apart side-by-side along each blade 2. As previously mentioned, each cutting element may be brazed to a carrier which is secured within a pocket in the blade 2, or the substrate of the cutting elements may be of sufficient length to be received directly in the pocket. The cutters are arranged in a generally spiral configuration over the leading face of the drill bit so as to form a cutting profile which sweeps across the whole of the bottom of the borehole being drilled as the bit rotates.

**[0023]** In Figures 1 and 2 all of the cutting elements on the drill bit are shown as being "pointed" cutters, each being formed with a cutting apex defined between two adjacent regions of the peripheral surface which are disposed at an angle to one another. However, it will be appreciated that it is not essential, according to the present invention, for all of the cutting elements on the drill bit to be of this type and some of the cutting elements may be of other shapes, for example they may be circular or part-circular cutting elements, particularly in the gauge region of the drill bit.

**[0024]** The bit body is formed with a central passage (not shown) which communicates through subsidiary passages with nozzles 4 mounted in the leading surface

of the bit body. Drilling fluid under pressure is delivered to the nozzles through the internal passages and flows outwardly through the spaces between adjacent blades for cooling and cleaning the cutters. The spaces between the blades 2 lead to peripheral junk slots 5, or to internal passages 6 in the bit body, through which the drilling fluid flows upwardly to the annulus between the drill string and the surrounding formation, passing upwardly through the annulus to the surface. The junk slots 5 are separated by gauge pads 7 which bear against the side wall of the borehole and are formed with bearing or abrasion inserts (not shown).

**[0025]** The bit body and blades may be machined from metal, usually steel, which may be hardfaced. Alternatively the bit body, or a part thereof, may be moulded from matrix material using a powder metallurgy process. The general construction of such drill bits, and their methods of manufacture, are well known in the art and will not be described in further detail.

**[0026]** Figures 3 and 4 show a preform cutting element according to the present invention which may be employed on a rotary drag-type drill bit of the above-described kind, or other form of drag-type drill bit.

**[0027]** The cutting element comprises a front facing table 10 of polycrystalline diamond bonded to a substrate 12 of cemented tungsten carbide. The facing table 10 is co-extensive with the substrate 12 so that the whole of the peripheral edge of the facing table is exposed around the periphery of the cutting element.

**[0028]** As may be seen from Figure 3, one portion 14 of the periphery of the cutting element is part-circular and extends around approximately half of the periphery of the element. The remainder of the periphery of the cutting element is defined by two substantially straight regions 16 of the periphery which are arranged at an angle to one another so as to define between them a generally pointed cutting apex 18. In use, the cutting element is so mounted on the drill bit that the cutting apex 18 engages the formation being drilled and, as the bit rotates, cuts the formation with a "scribing" action.

**[0029]** In order to reduce the susceptibility of the cutting apex 18 to rapid wear and impact damage, the facing table 10 is formed with a thickened rim 20 which extends continuously around the whole periphery of the facing table and thus forms part of the whole periphery of the cutting element. The thickened peripheral rim 20 projects into a correspondingly shaped peripheral recess in the substrate 12 and is bonded to the substrate during the process of forming the cutting element.

**[0030]** The thickened rim may project from the rear surface of the facing table 10 by any desired distance, but the distance is preferably at least equal to the thickness of the top part of the facing table 10 and may be up to several times its thickness. As may be seen from Figure 4, the rim 20 extends more than halfway through the thickness of the cutting element as a whole.

**[0031]** The portion 22 of the rear surface of the facing table 10 which lies within the rim 20 is circular, as best

seen in Figure 3. However, this portion may be of any other shape. For example, the peripheral rim 20 may be of substantially constant thickness, in which case the region 22 will be of an overall shape corresponding to the overall outer shape of the facing table 10.

**[0032]** In the arrangement shown, the region 22 of the rear surface of the facing table 10 is planar, but this surface might also be configured, i.e. formed with ribs or other protrusions on the rear surface of the facing table which engage within correspondingly shaped recesses in the substrate. Similarly, the surface of the thickened rim 20 remote from the facing table 10 may also be configured.

**[0033]** It will be seen that the provision of the thickened rim 20 provides a more substantial body of polycrystalline diamond adjacent the cutting apex 18 than would be the case if the facing table 10 were of substantially uniform thickness. This extra body of polycrystalline diamond thus protects the cutting apex 18 against rapid wear and impact damage. At the same time the rim 20 serves to enhance the mechanical interlock between the diamond facing table and the substrate 12 thus reducing the risk of separation of the facing table from the substrate under the high temperatures and stresses to which such cutting elements are subjected in use downhole.

**[0034]** In the modified arrangement of Figures 5 and 6 the peripheral rim 24 is narrower in width than in the arrangement of Figure 3 so that it does not extend continuously around the whole periphery of the cutting element but provides a thickened portion 26 adjacent the cutting apex 28 of the cutting element, and a part-annular portion 30 extending around the part-circular portion of the cutting element.

**[0035]** In the arrangement of Figures 7 and 8 the protuberance 32 projecting into the substrate 34 from the rear surface of the polycrystalline diamond facing table 36 is generally triangular in cross-section so as to provide additional strength to the periphery of the cutter only in the vicinity of the cutting apex 38. In this case the flat inner surface 40 of the protuberance 32 is inclined so that the protuberance decreases in cross section as it extends away from the facing table 36.

**[0036]** Figures 9 and 10 show a modified arrangement where the inner surface 42 of the generally triangular protuberance 44 is convexly curved as well as being inclined.

**[0037]** Figures 11 and 13 show a modification of the arrangement of Figures 9 and 10 where the protuberance 46 has a convexly curved inner surface which is stepped, as indicated at 48, so that the protuberance 46 again reduces in cross section as it extends away from the diamond facing table.

**[0038]** Figures 13 and 14 also show an arrangement where the protuberance 50 has a stepped inner surface, but in this case the inner surface 52 of the protuberance is concave and is provided with three steps rather than the two steps of Figures 9 and 10.

**[0039]** In the arrangement of Figures 15 and 16 the protuberance 54 projecting from the rear surface of the facing table 56 extends across the whole width of the cutting element from the cutting apex 58 to a region 60 of the part circular peripheral surface of the cutting element opposite the cutting apex 58.

**[0040]** Figures 17 and 18 show an arrangement in which the periphery of the cutting element is formed with two spaced cutting apices 62, 64 separated by a concave portion 66 of the periphery of the cutting element. In this case the protuberance is again in the form of a thickened rim 68 which projects into the substrate 70 from the rear surface of the diamond facing table 72. The thickened rim 68 extends around the whole periphery of the cutting element so as to provide support for both cutting apices 62 and 64.

**[0041]** As shown in Figure 17 imaginary lines 74 bisecting the two cutting apices 62, 64 are substantially parallel so that the apices point in the same direction and thus act on the formation simultaneously.

**[0042]** Figures 19 and 20 show a cutting element similar to that of Figures 17 and 18 but formed with six cutting apices 76, 78. The two leading apices 76 are connected by a concave portion 80 of the periphery of the cutting element whereas the other apices 78 are defined by generally straight edges meeting at an angle in a saw-tooth configuration. In this arrangement also the protuberance on the diamond facing table comprises a continuous thickened rim extending around the whole periphery of the cutting element.

**[0043]** Figures 21 and 22 shows a cutting element formed with three cutting apices 79. In this case there are provided three parallel elongate protuberances 80 projecting from the rear surface of the facing table 81. Each protuberance 80 extends across the whole width of the cutting element from an apex 79 to a region of the peripheral surface of the cutting element opposite that apex.

**[0044]** Figures 49 and 50 show a cutting element similar to those shown in Figures 15 to 22. In this arrangement, however, the apices 200, 202 are spaced apart from one another, a relatively flat surface 204 being located therebetween. A pair of protuberances 206, 208 which extend away from the table 210 correspond with the apices 200, 202. Each protuberance 206, 208 extends only part way across the cutting element. A cutting element of this type is particularly useful in drilling the sidewall of a borehole, with the cutting element oriented such that the relatively flat surface 204 is arranged to contact the sidewall. The protuberances 206, 208 tend to help prevent spalling and chipping of the cutting element.

**[0045]** As previously mentioned in relation to Figures 3 and 4, the inner region of the rear surface of the facing table may be planar or configured, for example by being formed with ribs or other protrusions on the rear surface of the facing table which engage within correspondingly shaped recesses in the substrate. As is well known, pre-

form cutting elements of the type to which the present invention relates are normally manufactured by forming the substrate in the required configuration from compacted powdered material, such as powdered tungsten carbide. A layer of diamond particles is then applied to the front surface of the substrate and the assembly is subjected to very high pressure and temperature in a high pressure, high temperature press so as to bond the particles together, and the layers to one another, to produce a unitary element. Any required configuration of the interface between the substrate and the facing table is normally effected by pre-shaping the front face of the substrate to which the layer of diamond particles is applied.

**[0046]** Figures 23 and 24 show the shapes of substrates designed to provide the required configured interface between the facing table and substrate in the finished cutting element.

**[0047]** In the arrangement of Figure 23, the substrate 82 is formed with a peripheral rebate 84 which surrounds a circular central raised portion 86. The raised portion 86 is formed around its periphery with alternating long and short grooves 88 which extend inwardly from the periphery of the raised portion 86 at an angle to the radial direction. The grooves 88 reduce in depth as they extend inwardly, leaving a central planar region 90 at the centre of the raised portion 86.

**[0048]** When the layer of diamond is applied to the substrate 82, the body of diamond filling the rebate 84 forms a rearwardly projecting peripheral rim on the rear surface of the diamond facing table, and the bodies of diamond filling the grooves 88 provide protuberances in the form of ribs on the circular region of the rear face of the facing table within the peripheral rim. These ribs increase the mechanical interlock between the facing table and substrate and tend to increase the resistance of the cutting element to impact damage and to spalling or delamination of the facing table from the substrate.

**[0049]** In the arrangement of Figure 3, and indeed in any of the arrangements according to the present invention, the substrate may be initially in the form of a completely circular tablet to which the layer of diamond particles is applied so that the preform element, as it emerges from the high pressure high temperature press, is completely circular. The shaping of the periphery of the element to form the cutting apex, or several cutting apices, may then be effected by a further forming operation in which parts of the periphery of the cutting element are removed and/or shaped by any appropriate mechanical shaping process, such as grinding or EDM. The shape shown diagrammatically in Figure 23, therefore, will usually be the shape of the substrate portion of the finished cutting element, after machining, rather than the shape of the compacted powder substrate component to which the layer of diamond particles is applied prior to forming the basic cutting element in the press.

**[0050]** Figure 24 is a similar view to Figure 23 showing an alternative form of substrate 92. In this case the inner

wall 94 of the peripheral rebate 96 around the upper surface of the substrate is inclined so that the raised portion 98 is generally frusto-conical in shape, and the inner surface of the peripheral rim on the diamond facing table is inclined.

**[0051]** In this case, grooves 100 extending inwardly from the periphery of the raised portion 98 also extend across the rebate 96 and intersect the outer surface of the substrate 92.

**[0052]** Figure 23 showed a comparatively thin substrate 82 suitable for use, for example, in the case where the finished preform cutting element is to be brazed to a separate supporting post or stud. In the arrangement of Figure 24, the substrate 92 is of greater axial length so as to provide a finished preform cutting element which may be directly mounted in a suitably shaped pocket in the bit body.

**[0053]** In all of the arrangements thus far described, the peripheral surface of each cutting element is shown as being at right angles to the front exposed surface of the diamond facing table. However, additional strength and support may be given to the cutting apex by inclining the peripheral surface of the cutting element outwardly as it extends away from the front surface of the facing table on either side of the cutting apex. This increases the relative size of the body of protuberance material and substrate material which lies beneath the top of the cutting apex of the element so as to support the apex against wear and impact damage. Figures 25-31 show preform cutting elements of this type.

**[0054]** In each case the cutting element is initially formed as a circular cylindrical element having a circular front facing table bonded to a circular substrate. The required configuration of the finished element is then subsequently achieved by grinding, EDM, or any other suitable form of machining.

**[0055]** In the arrangement of Figures 25 and 26 a single cutting apex 102 is provided by forming two inclined flats 104 approximately at right angles to one another. As a result of the cylindrical shape of the basic element and the inclination of the flats, each surface 104 reduces in width as it extends away from the facing table 106 to the rear surface 108 of the substrate 110. The front face 106 of the diamond facing table is preferably chamfered around its whole periphery, as indicated at 112.

**[0056]** The included angle between the flats 104, defining the pointedness of the cutting apex, may be of any desired magnitude, for example it may be within the range of 60°-120°.

**[0057]** In the modified arrangement of Figures 27 and 28 the tip of the cutting apex is chamfered and radiussed as indicated at 114. In this case the periphery of the diamond facing table is not chamfered, although this may be effected if desired.

**[0058]** Figures 29-31 are diagrammatic perspective views showing further modifications of the shape of cutting elements shown in Figures 25 and 26.

**[0059]** In the cutting element of Figure 29, the ma-

chined flanks 116 on either side of the cutting apex 118 are cylindrically and convexly curved so that the peripheral stretches 120 of the facing table 122 on either side of the cutting apex 118 are also convexly curved.

**[0060]** In the cutting element of Figure 30 the flanks 124 on either side of the cutting apex 126 are cylindrically and concavely curved. A chamfer 128 is also formed on each side of the cutting apex 126 and steps 130 are formed between each concave flank 124 and the part-circular outer periphery 132 of the cutting element. Figure 31 is a modification of the arrangement shown in Figure 30 where the flanks 124A are also concavely curved in the direction of the axis of the cutting element so as to provide a "hollow ground" effect on either side of the cutting apex 126A. The flanks may also be "hollow ground" in the arrangement of Figures 25-28 where the flanks 104 are straight in cross-section.

**[0061]** Figure 32 shows an arrangement where the machined flanks 134 on each side of the cutting apex 136 are more steeply inclined than in the previously described arrangements so as to intersect the bottom surface of the substrate 138 opposite the facing table 140. As a result the cutting apex 136 effectively extends for the whole axial length of the cutting element, but the presence of a remaining portion 142 of the periphery of the cutting element below the cutting apex 136 has the effect that the cutting apex becomes increasingly broad as wear of the cutting element progresses in use.

**[0062]** In all of the arrangements of Figures 25-32 the rear surface of the facing table of the cutting element may be non-planar, i.e. provided with at least one protuberance which projects into a correspondingly shaped recess in the front surface of the substrate, in accordance with the present invention. For example, the protuberance may be of any of the configurations previously described with reference to Figures 3-16. However, the configurations shown in Figures 25-32 may also be employed in cutting elements where the interface between the facing table and substrate is not configured according to the present invention, for example where the interface is substantially planar.

**[0063]** Figures 33-48 show further variations of preform cutting element in accordance with the present invention.

**[0064]** Figures 33-38 show variations of the arrangement shown in Figures 15 and 16 where the protuberance on the rear surface of the diamond layer is thickest in the centre of the diamond layer, extending diametrically across the cutting element from the cutting apex. In the arrangement of Figures 33 and 34 the underside of the protuberance on diamond layer 144 has an inverted ridge configuration formed by two flat inclined surfaces 146 on each side of the centreline 148 of the protuberance. The arrangement of Figures 35 and 36 is similar except that the surfaces 150 on each side of the centreline 152 are cylindrically and concavely curved.

**[0065]** In the arrangement of Figures 37 and 38 the parallel-sided protuberance 154 extending from the rear

surface of the diamond layer 156 is generally triangular in cross-section. It extends diametrically away from the cutting apex of the cutting element and across only a part of the width of the diamond layer 156.

**[0066]** Instead of the cutting apex of the cutting element being strengthened by a protuberance on the underside of the diamond facing table, the desired additional strength may be provided by forming the diamond table with a region of increased abrasion resistance which lies adjacent to the cutting apex and, preferably, forms part of the periphery of the cutting element at the cutting apex. Arrangements of this kind are shown by way of example in Figures 39-44.

**[0067]** In the arrangement of Figures 39 and 40 the diamond facing table 158 comprises a central strip 160 of greater abrasion resistance flanked by two side portions 162 of lesser abrasion resistance. The strip 160 extends diametrically across the facing table 158 from the cutting apex 164 to a region opposite the cutting apex. The end of the strip 160 is exposed at the periphery of the cutting element and thus itself forms the cutting apex 164.

**[0068]** Figures 41-44 show similar arrangements where the strip of greater abrasion resistance is of different cross-sectional shapes. In the arrangement of Figures 41 and 42 the strip 166 of greater abrasion resistance is generally triangular in cross-section. In Figure 43 and 44 the strip 168 extends across substantially the whole width of the facing table 170 and comprises a central ridge 172 flanked by two cylindrical and concave surfaces 174.

**[0069]** In any of the arrangements last described, the protuberance on the rear surface of the diamond facing table, and/or the more abrasion resistant strip included in the facing table, may extend only partly across the diameter of the facing table. Alternatively or additionally the shape of the strip may vary according to the diameter of the cutting element.

**[0070]** Thus, Figures 45 and 46 show an arrangement similar to Figures 33 and 34, but where the protuberance on the underside of the diamond facing table 176 extends away from the cutting apex 178 across only a portion of the diameter of the cutting element, the part 176A of the facing table beyond the protuberance 176 being of substantially constant thickness.

**[0071]** In the arrangement of Figures 47 and 48 the strip 180 of more abrasion resistant diamond material incorporated in the diamond facing table 182 extends only across a part of the diameter of the cutting element as it extends away from the cutting apex 184.

**[0072]** The feature of incorporating in the diamond facing table a portion of polycrystalline diamond which is of greater abrasion resistance may be provided in any of the cutting elements according to the invention and as described above in relation to Figures 3-38.

**[0073]** The greater abrasion resistance of the portion of the diamond facing table may be achieved by any of the means of increasing abrasion resistance which are

well known in the art. For example abrasion resistance may be varied by variation in the mean diameter of the particles of diamond, or other superhard material, from which the front facing table of the cutting element is formed and/or by variation in the packing density of the particles.

**[0074]** In all of the arrangements described above the protuberance on the diamond facing table forms part of the peripheral surface of the cutting element adjacent the cutting apex of the element. However, the invention does not exclude arrangements where the protuberance is spaced inwardly from the periphery of the cutting element but is still located in a position where it can provide support and protection to the cutting apex. For example, the protuberance may be located in a position where it is not exposed at the periphery of the cutting element and does not come into contact with the formation until some wear of the cutting element has occurred.

## Claims

1. A preform cutting element, for a rotary drag-type drill bit, including a facing table (10, 36, 56, 72, 81, 144, 160, 180, 210) of superhard material having a front face and a rear surface bonded to the front surface of a substrate (12, 34, 70, 204) which is less hard than the superhard material, the cutting element having a peripheral surface which includes at least one cutting apex (18, 28, 38, 58, 62, 64, 76, 78, 79, 164, 178, 184, 200, 202) defined between two adjacent regions of the peripheral surface which are disposed at an angle to one another, and the rear surface of the facing table being formed with at least one protuberance (20, 26, 32, 44, 46, 50, 54, 68, 206, 208) which projects into a correspondingly shaped recess in the substrate.
2. A preform cutting element according to Claim 1, wherein at least part of said protuberance (20, 26, 32, 44, 46, 50, 54, 68, 206, 208) on the facing table is located adjacent said cutting apex (18, 28, 38, 58, 62, 64, 76, 78, 79, 164, 178, 184, 200, 202).
3. A preform cutting element according to Claim 2, wherein at least a part of the protuberance forms part of the periphery of the cutting element at said cutting apex (18, 28, 38, 58, 62, 64, 76, 78, 79, 164, 178, 184, 200, 202).
4. A preform cutting element according to any of the preceding claims, wherein the rear surface of the facing table and the front surface of the substrate of the cutting element are co-extensive.
5. A preform cutting element according to any of the preceding claims, wherein said protuberance comprises a thickened rim (30) extending around at

least a part of the periphery of the facing table and projecting into a correspondingly shaped recess which extends around at least a part of the periphery of the substrate.

6. A preform cutting element according to Claim 5, wherein the thickened rim (30) extends substantially continuously around the whole periphery of the facing table.

7. A preform cutting element according to Claim 6, wherein the outer surface of the thickened rim (30) forms part of the whole periphery of the cutting element.

8. A preform cutting element according to Claim 7, wherein the region of the rear surface of the facing table within the thickened rim (30) is circular.

9. A preform cutting element according to Claim 5, wherein the thickened rim (30) comprises two or more rim portions spaced apart around the periphery of the cutting element, at least one portion of the rim forming part of the periphery of the cutting element at said cutting apex.

10. A preform cutting element according to Claim 9, wherein the region of the rear surface of the facing table within the thickened rim portions is circular.

11. A preform cutting element according to any of Claims 1 to 4, wherein the protuberance (32, 44, 46, 50) is generally triangular in configuration, comprising an inner surface bonded to the substrate and two outer surfaces defining part of the outer periphery of the cutting element on either side of the cutting apex.

12. A preform cutting element according to Claim 11, wherein the inner surface of the protuberance (32, 44, 46, 50) is flat, concave or convex.

13. A preform cutting element according to Claim 11 or Claim 12, wherein the protuberance (32) reduces in cross-section as it extends away from the rear surface of the facing table.

14. A preform cutting element according to Claim 13, wherein the inner surface (40) of the protuberance is inclined.

15. A preform cutting element according to Claim 13, wherein the inner surface (48, 52) of the protuberance is stepped.

16. A preform cutting element according to any of Claims 1 to 4, wherein the protuberance on the rear surface of the facing table forms part of the periph-

ery of the cutting element at said cutting apex, and extends inwardly away from the cutting apex into the interior of the substrate.

5 17. A preform cutting element according to Claim 16, wherein the protuberance (54, 80, 160, 166) extends across the full width of the cutting element so as also to form part of the periphery of the cutting element in a region thereof opposite said cutting apex.

10 18. A preform cutting element according to Claim 16 or Claim 17, wherein the protuberance has substantially parallel side surfaces bonded to the sides of a recess in the front surface of the substrate.

15 19. A preform cutting element according to any of the preceding claims, wherein the cutting element is formed with a plurality of cutting apices (62, 64, 76, 78, 79, 200, 202) spaced apart around the periphery thereof.

20 20. A preform cutting element according to Claim 19, wherein the part of the periphery between two adjacent cutting apices is smoothly concave.

25 21. A preform cutting element according to Claim 19 or Claim 20, wherein imaginary lines bisecting the cutting apices are substantially parallel so that the cutting apices point in generally the same direction.

30 22. A preform cutting element according to any of the preceding claims, wherein the periphery of the cutting element is part-circular.

35 23. A preform cutting element according to Claim 22, wherein one or both regions of the periphery on either side of a cutting apex extend generally tangentially to a part-circular portion of the periphery of the cutting element.

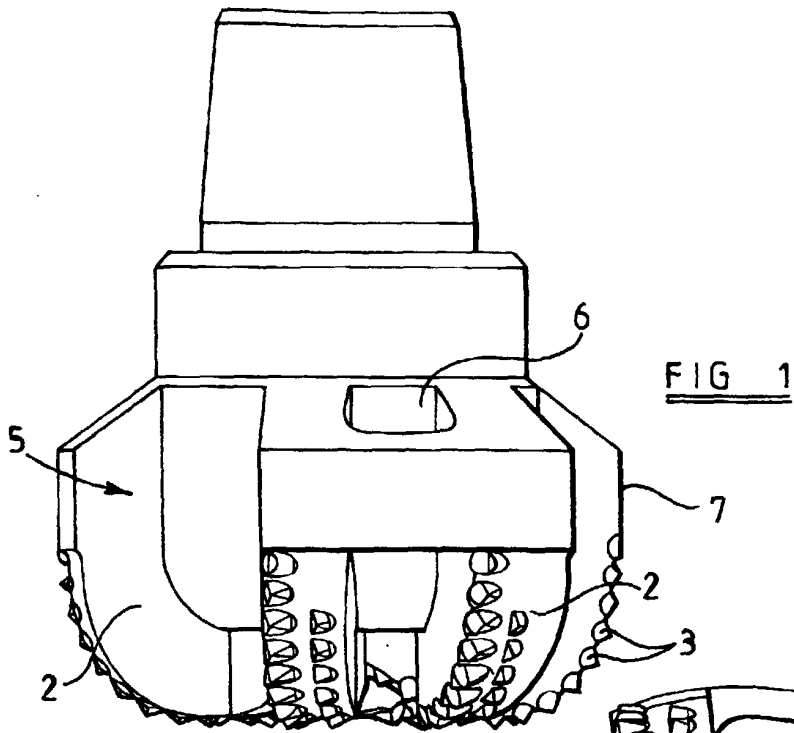

FIG 2

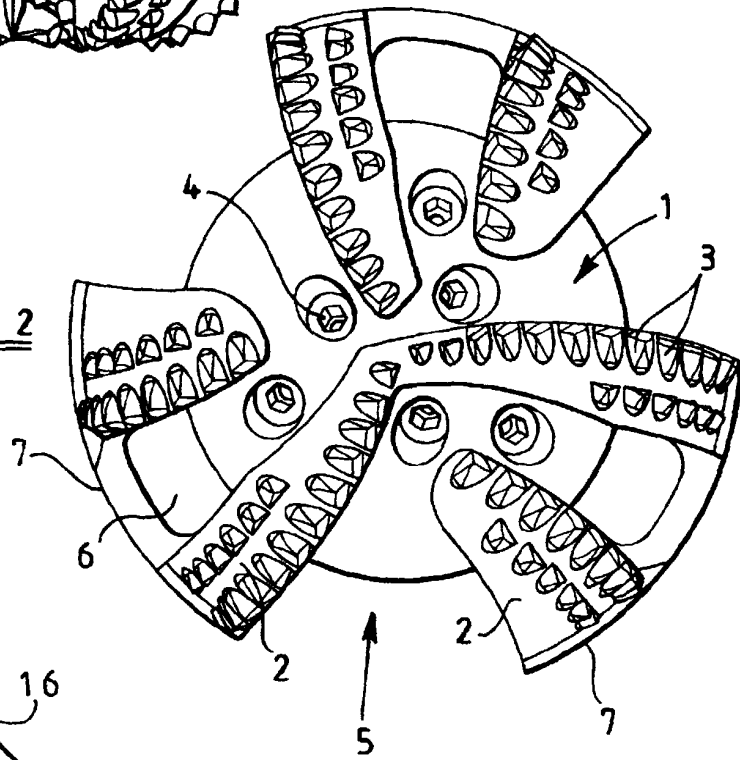
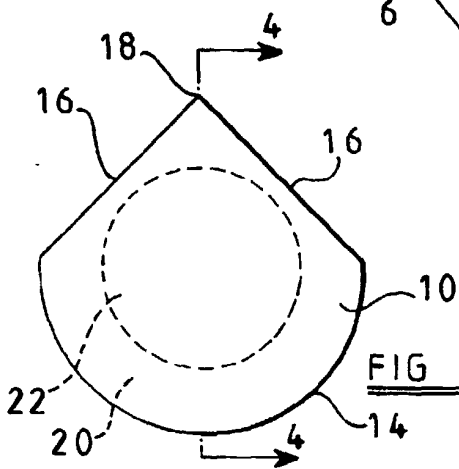

FIG 3



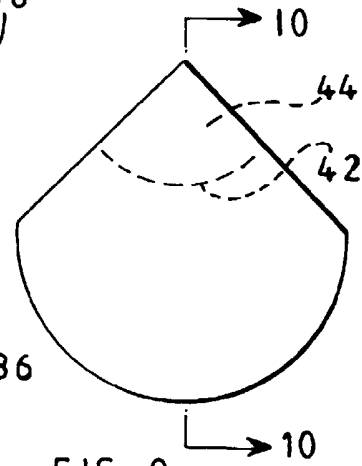
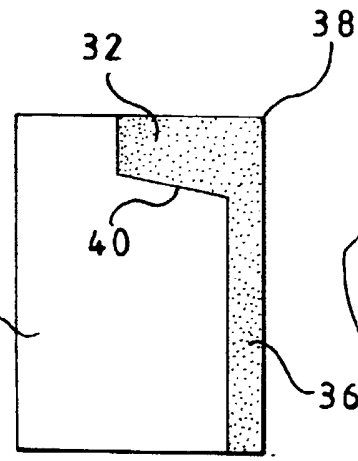
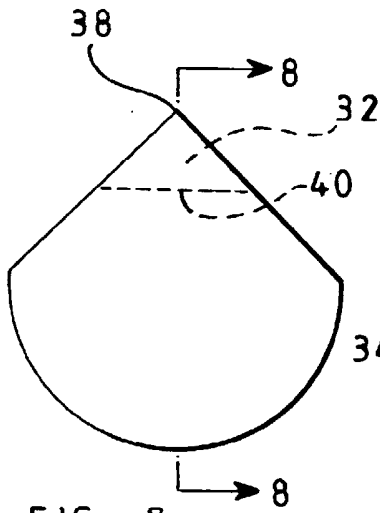
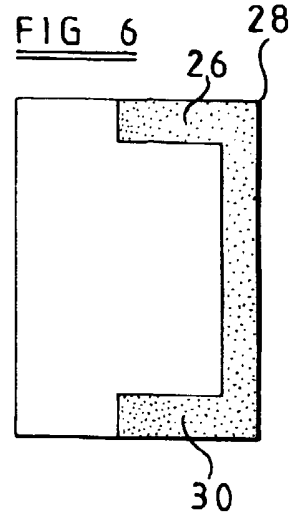
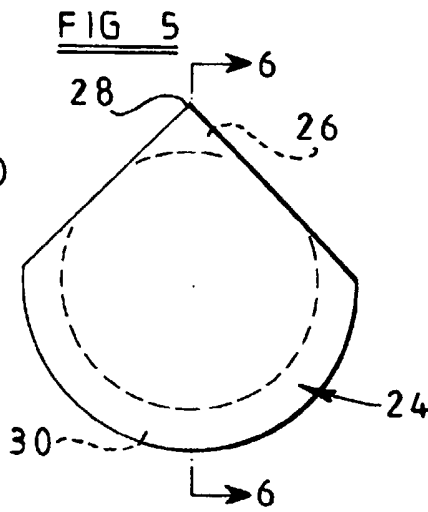
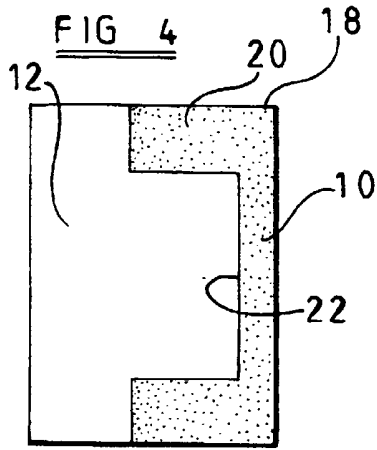

FIG 7

FIG 8

FIG 9

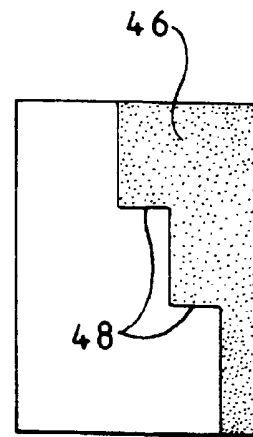
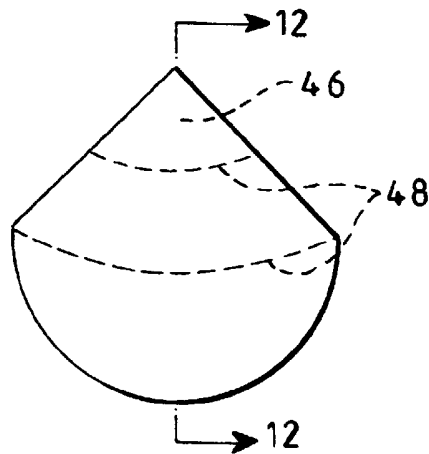
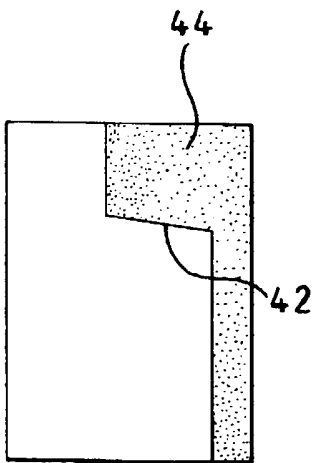

FIG 10

FIG 11

FIG 12

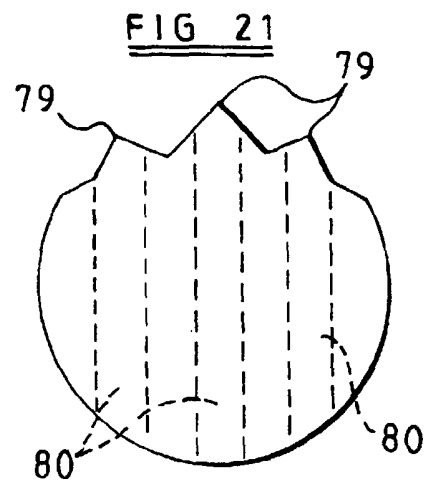
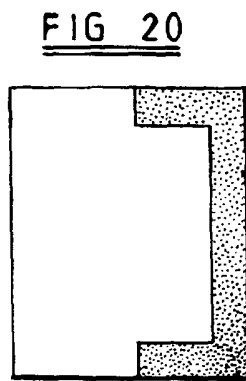
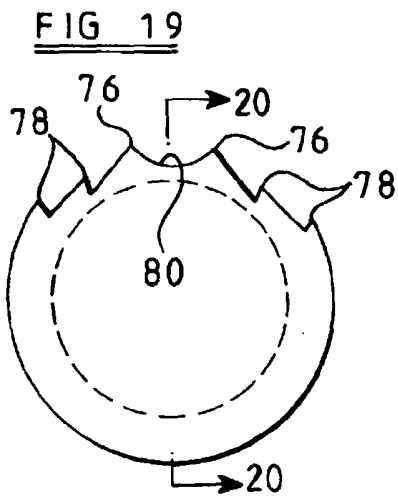
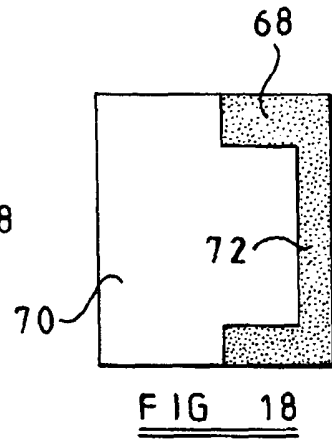
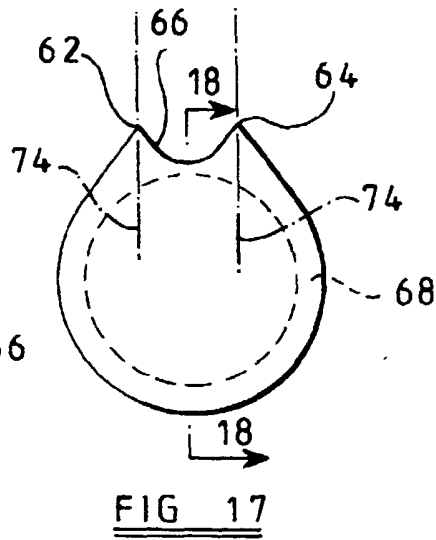
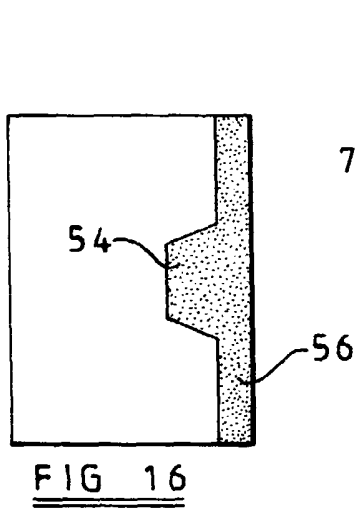
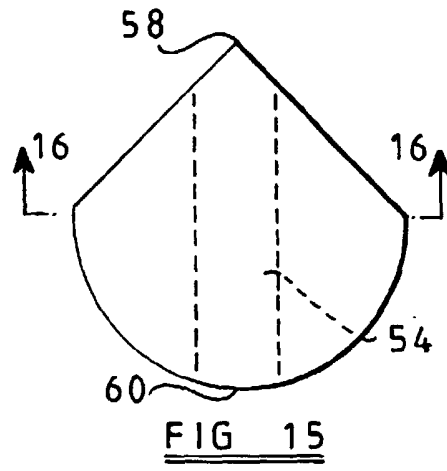
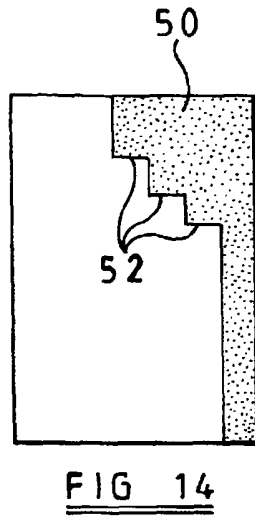
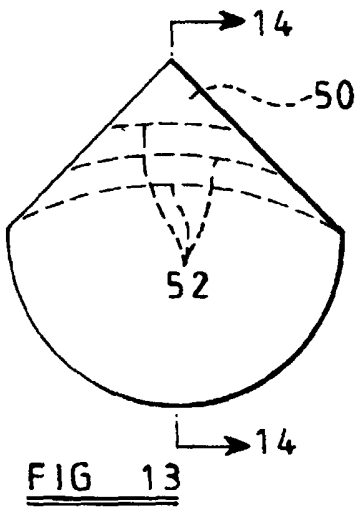

FIG 22

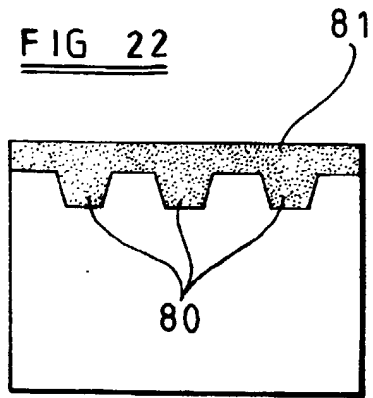

FIG 23

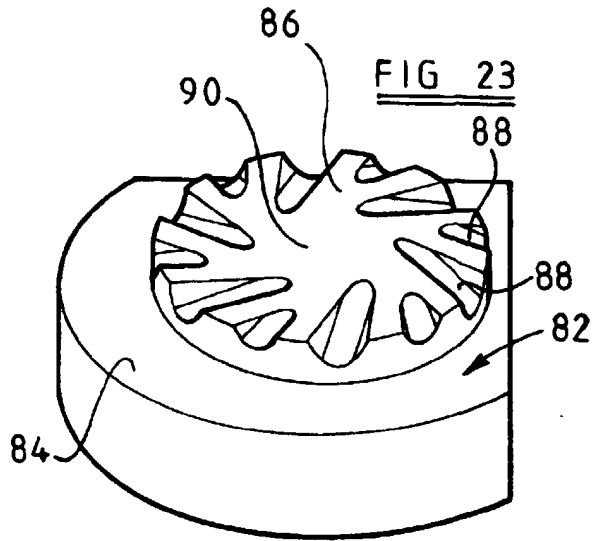

FIG 24

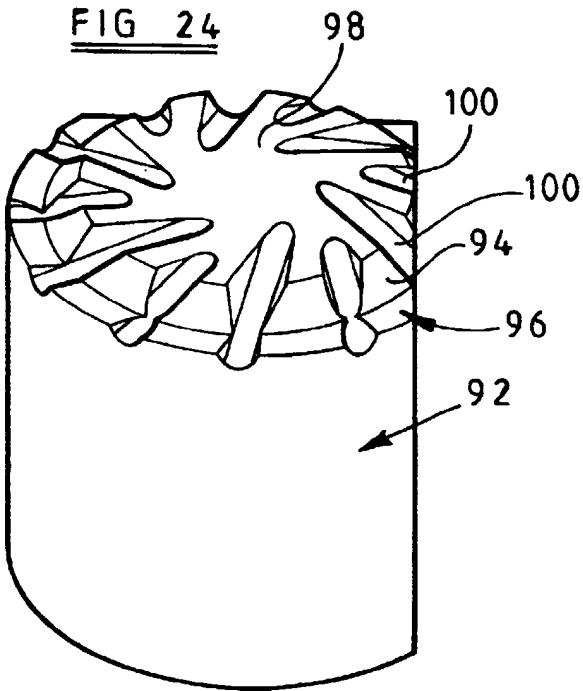

FIG 25

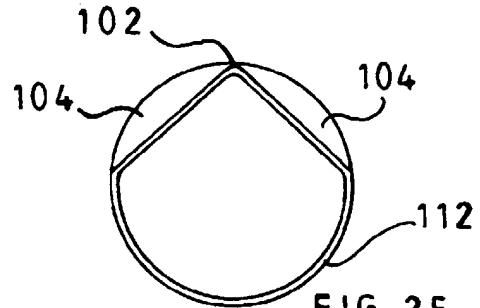

FIG 26

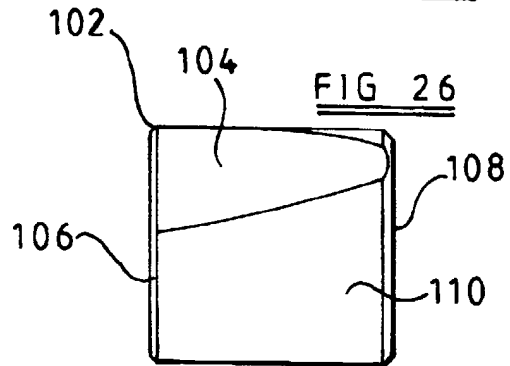

FIG 27

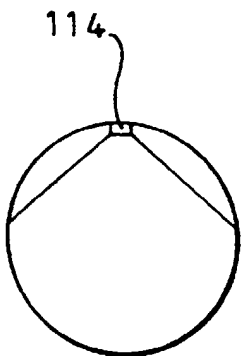

FIG 28

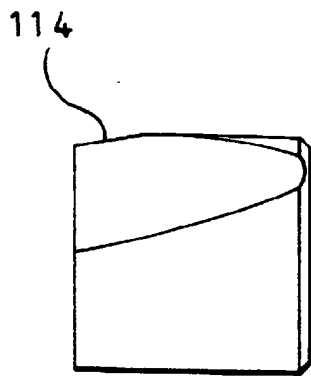
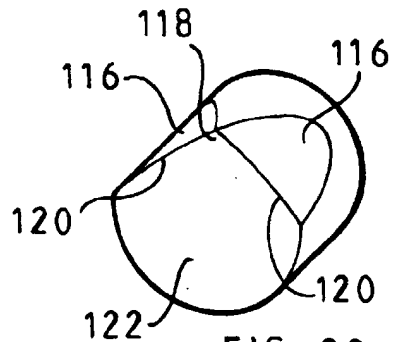

FIG 29



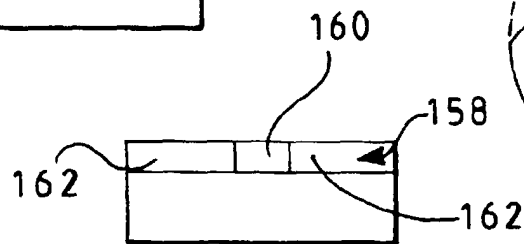
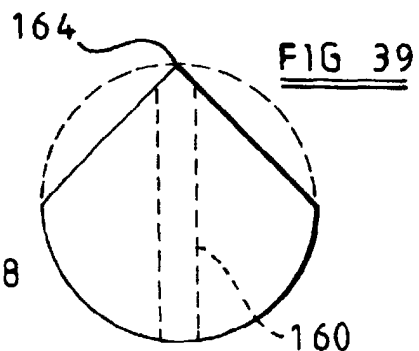
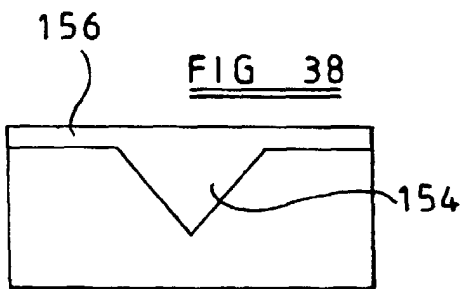
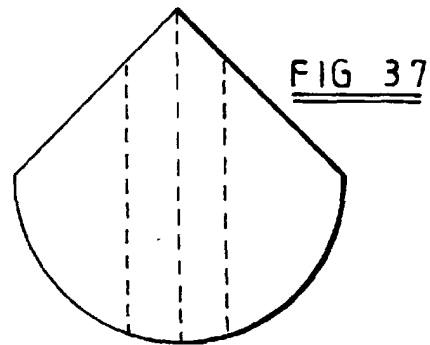
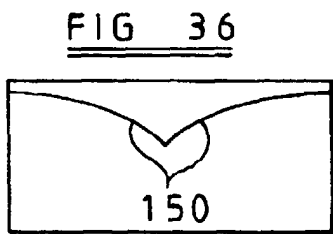
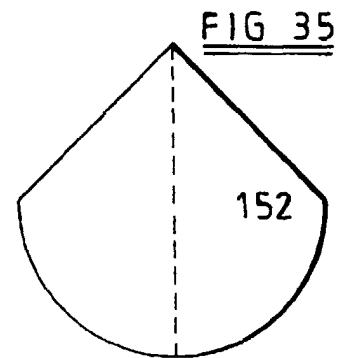
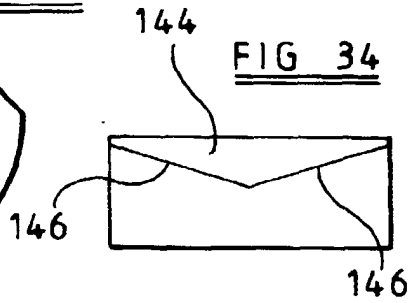
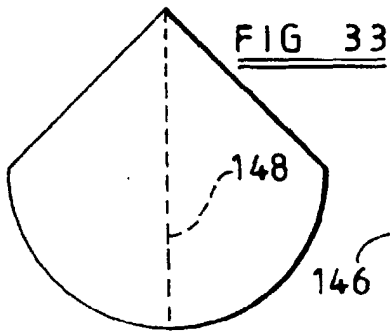
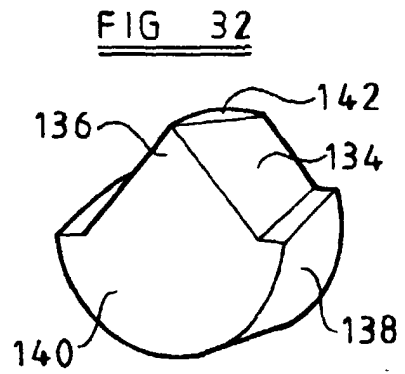
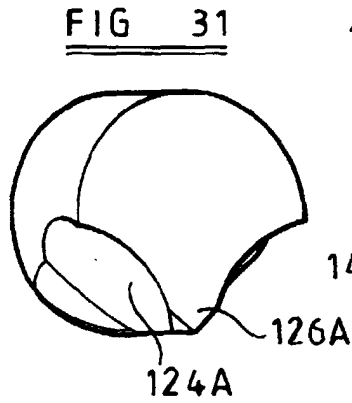
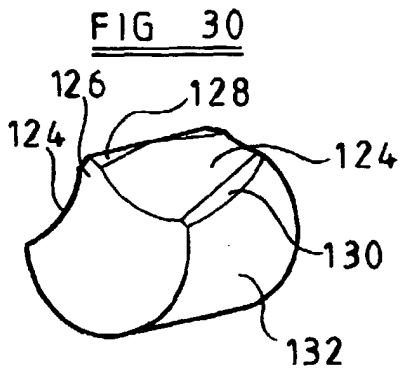

FIG 41

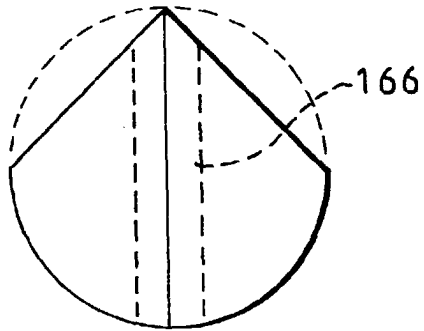

FIG 42

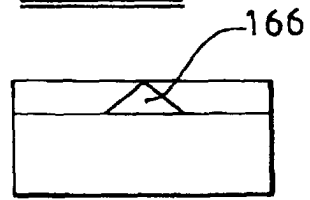

FIG 43

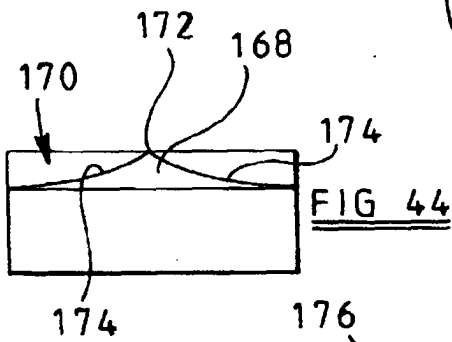
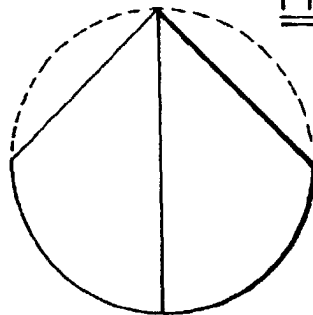

FIG 45

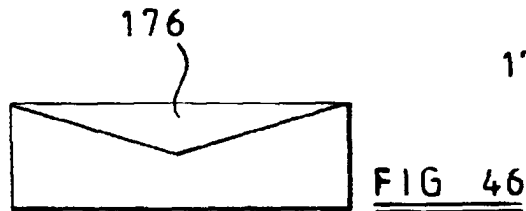
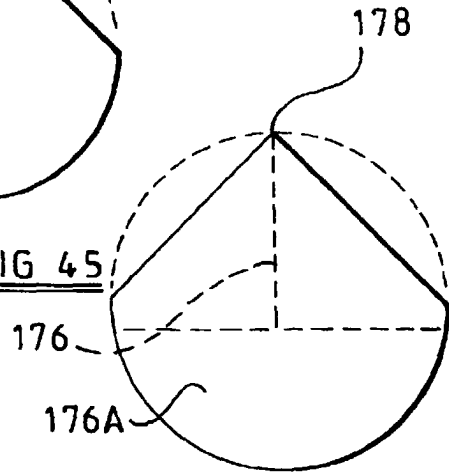

FIG 46

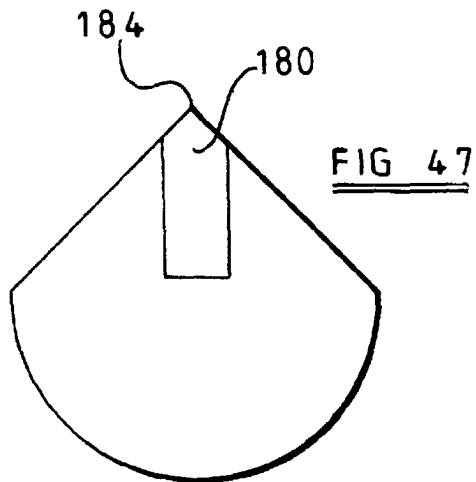

FIG 47

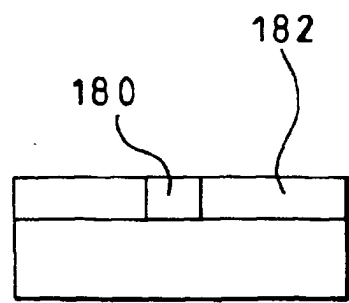

FIG 48

FIG 49

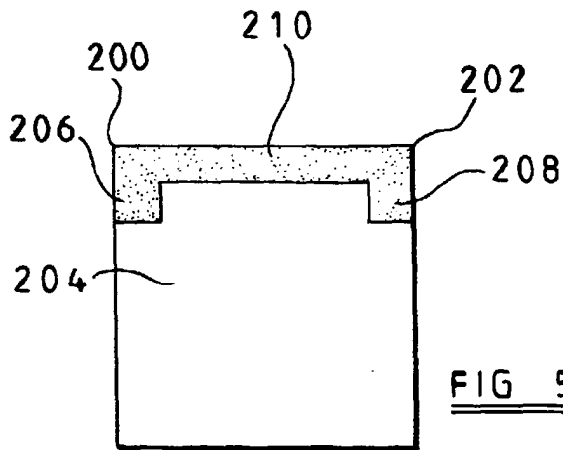
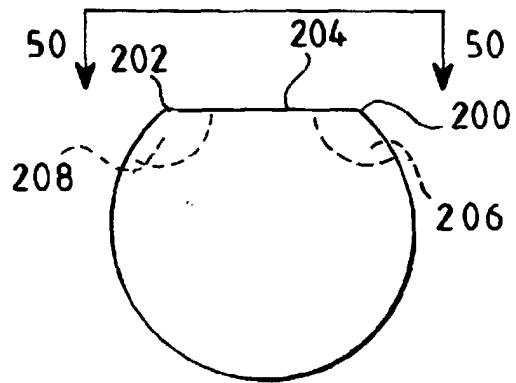

FIG 50