

No. 828,551.

PATENTED AUG. 14, 1906.

E. R. JOHNSON.
SOUND BOX FOR TALKING MACHINES.

APPLICATION FILED NOV. 12, 1904.

Fig 1

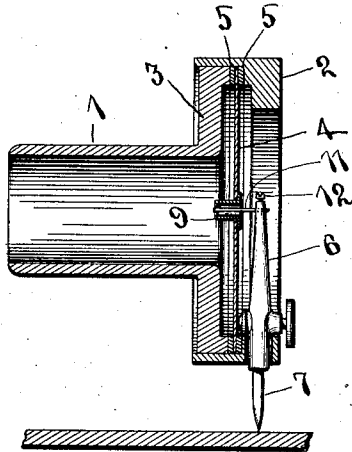
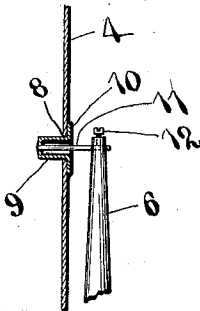

Fig 2.



WITNESSES:

H. Hartman
Edw. W. Vaill Jr.

INVENTOR
Eldridge R. Johnson.
BY *Wm. Peck*
ATTORNEY.

UNITED STATES PATENT OFFICE.

ELDRIDGE R. JOHNSON, OF MERION, PENNSYLVANIA, ASSIGNOR TO
VICTOR TALKING MACHINE COMPANY, A CORPORATION OF NEW
JERSEY.

SOUND-BOX FOR TALKING-MACHINES.

No. 828,551.

Specification of Letters Patent.

Patented Aug. 14, 1906.

Application filed November 12 1904. Serial No. 232,391.

To all whom it may concern:

Be it known that I, ELDRIDGE R. JOHNSON, a citizen of the United States, and a resident of Merion, county of Montgomery, State of Pennsylvania, have invented certain new and useful Improvements in Sound-Boxes for Talking-Machines, of which the following is a full, clear, and complete disclosure.

In the reproduction of sound from talking-machine records, either of the type having vertical undulations in the record-grooves or of the type having horizontal undulations in the said groove, it is well known that many sounds are reproduced which are due to imperfections in the construction and disposition of the parts of the talking-machine. One of the most serious of these undesirable sounds I have found to be due to the comparatively stiff and short connection hitherto employed between the end of the stylus-bar and the diaphragm. This connection tends to oscillate about the center of the oscillation of the stylus-bar, and therefore delivers the vibrations to the diaphragm at constantly-varying angles to the plane of the diaphragm, dependent upon the position of the stylus-bar at any particular moment.

The object of my invention is to provide a construction in which a long and flexible connection may be used between the end of the stylus-bar and the diaphragm, so that the angle which said connection subtends as the stylus-bar oscillates will be greatly reduced and that the connection will bend or be flexible to transmit the vibrations in a direction substantially perpendicular to the diaphragm irrespective of the position of the stylus-bar in its oscillation about its fulcrum.

A further object of my invention is to provide a construction in which such long and flexible connection may be applied to sound-boxes constructed and arranged in the ordinary manner.

For a full, clear, and exact description of one embodiment of my invention reference may be had to the following specification and to the accompanying drawings, forming a part thereof, in which—

Figure 1 is a central longitudinal sectional view of a sound-box embodying my improvement, and Fig. 2 is a similar view showing the diaphragm and stylus-bar separated from the sound-box.

Referring to the drawings, the numeral 1 indicates the tubular portion of the sound-box casing, which is adapted to be connected with the sound-conveying means or amplifying-horn, and 2 the outer cylindrical part of the casing thereof. The tubular portion 1 terminates in a disk-shaped portion 3, between which and the end of the cylindrical casing 2 the diaphragm 4 is retained, suitable gaskets 5 being inserted between said diaphragm and the adjacent portions of the casing.

The stylus-bar 6 is fulcrumed upon the cylindrical portion of the casing 2 in any well-known manner and has the stylus or needle 7 removably retained in its outer end. At the center of the diaphragm 8 I form an offset by providing the diaphragm with a small circular opening, through which projects a cylindrical or cup-shaped piece of metal 9, having an annular flange 10 at one end thereof, said annular flange contacting with and being secured to the outer side of the diaphragm 4. Said cup and flange are preferably stamped or spun from thin sheet metal and are made as light as is consistent with strength and durability. To the center of the end of the cup-shaped offset 9 I attach a small wire 11 or other suitable flexible connecting means, the opposite end of which is secured to the inner end of the stylus-bar 6, in this instance by means of the screw 12.

It will now be seen that when sounds are being reproduced from the record the stylus-bar 6 will be vibrated in the usual manner, and said vibrations will be transmitted to the diaphragm 4 at all times perpendicular to the plane of the diaphragm, whether the vibrating end of the stylus-bar to which the connection is secured be on one or the other side of its normal position.

Owing to the extension of the cup-shaped portion 9, the flexible wire connection 11 may be made much longer than is possible when said connection is attached directly to the center of the diaphragm, thus allowing said connection to subtend a smaller angle and to bend more easily to accommodate itself to the oscillatory motion of the stylus-bar 6 as it vibrates about its fulcrum.

Having thus described my invention, it will be obvious that certain changes may be made in the form, proportion, and arrange-

ment of parts without departing from the spirit and scope of my invention; but

What I claim, and desire to protect by Letters Patent of the United States, is—

5 1. In a sound-box for talking-machines, the combination with a stylus-bar, of a diaphragm, a small offset located on said diaphragm and extending in a direction away from said stylus-bar and a connecting-piece
10 between said stylus-bar and said offset the said connecting-piece being free to flex out of its axis at any point between its connecting ends.

15 2. In a sound-box for talking-machines, the combination with a stylus-bar, of a diaphragm, an offset located at the center of said diaphragm and extending in a direction away from said stylus-bar and a flexible connection between said stylus-bar and said offset
20 the said connection being free to flex out of its axis at any point between its connecting ends.

25 3. In a sound-box for talking-machines, the combination with a diaphragm, of a stylus-bar on one side of said diaphragm, a flexible connection carried by said stylus-bar and means to secure said flexible connection to said diaphragm at a point on that side of the diaphragm opposite to that on which said
30 stylus-bar is located the said connection being free to flex out of its axis between its points of contact with said diaphragm and stylus-bar.

35 4. In a sound-box for a talking-machine, the combination with a stylus-bar, of a diaphragm provided with an opening, a hollow body located in said opening with one of its ends secured to said diaphragm and with its
40 other end located on that side of the diaphragm opposite to that on which said stylus-bar is located, and a connection between said stylus-bar and said body the said connection being free to flex out of its axis between its connecting ends.

45 5. In a sound-box for a talking-machine, the combination with a stylus-bar, of a dia-

phragm provided with an opening, a hollow body located in said opening with one of its ends secured to said diaphragm and with its other end located on that side of the diaphragm opposite to that on which said stylus-bar is located, and a flexible connection between said stylus-bar and said body the said connection being free to flex out of its axis between its connecting ends. 50

55 6. In a sound-box for talking-machines, the combination with a stylus-bar, of a diaphragm provided with a small central aperture, a light hollow body having a flanged opening at one end and closed at the other end, the flanged open end being secured to the edge of said aperture and the closed end being located on that side of the diaphragm opposite to that on which said stylus-bar is located, and a connection between said stylus-bar and the closed end of said body. 60

65 7. In a sound-box for talking-machines, the combination with a stylus-bar, of a diaphragm provided with a small central aperture, a light hollow body flanged at one end and closed at the other end, the flanged end being open and secured to the edge of said aperture and the closed end being located on that side of the diaphragm opposite to that on which said stylus-bar is located, and a flexible connection between said stylus-bar and the closed end of said body. 70

75 8. In a sound-box for talking-machines, the combination with a plane diaphragm, a stylus-bar, a light hollow body secured to the central portion of said diaphragm and a straight flexible connection between said stylus-bar and said body, said connection being longer than the distance between the end of the stylus-bar and the plane of the diaphragm and being free to flex out of its axis. 80

In witness whereof I have hereunto set my hand this 10th day of November, A. D. 1904.

ELDRIDGE R. JOHNSON.

Witnesses:

JOHN T. GRADY,
HORACE PETTIT.