



US 20080098551A1

(19) **United States**

(12) **Patent Application Publication**
Yang

(10) **Pub. No.: US 2008/0098551 A1**

(43) **Pub. Date: May 1, 2008**

(54) **CLEANING BRUSH CAP**

(52) **U.S. Cl. 15/175; 15/247**

(76) **Inventor: Ya-Ching Yang, Taipei (TW)**

(57) **ABSTRACT**

Correspondence Address:
BIRCH STEWART KOLASCH & BIRCH
PO BOX 747
FALLS CHURCH, VA 22040-0747

The present invention provides a cleaning brush cap for capping a brush head of a cleaning brush. Said cleaning brush cap comprises: at least two main layers, superimposed to form a cap body having an interior space, wherein an opening is disposed on the lower end of the cap body such that the brush head of the cleaning brush is inserted into the interior space through the opening; at least two cleaning layers disposed on both surfaces of the cap body for taking away the filth; and at least one combination trace disposed on the surfaces of the cleaning layers for combining the main layers and the cleaning layers, wherein a margin is set between the combination trace and the edge of the cleaning layers, such that the edge of each of the layers forms becomes a loose border capable of cleaning small corners effectively. And an eccentric distance is provided between the middle section of the interior space and the opening, such that the cleaning brush cap can be pulled out easily.

(21) **Appl. No.: 11/808,882**

(22) **Filed: Jun. 13, 2007**

(30) **Foreign Application Priority Data**

Oct. 31, 2006 (TW) 095140110
Feb. 12, 2007 (TW) 096104948

Publication Classification

(51) **Int. Cl.**
A46B 17/04 (2006.01)

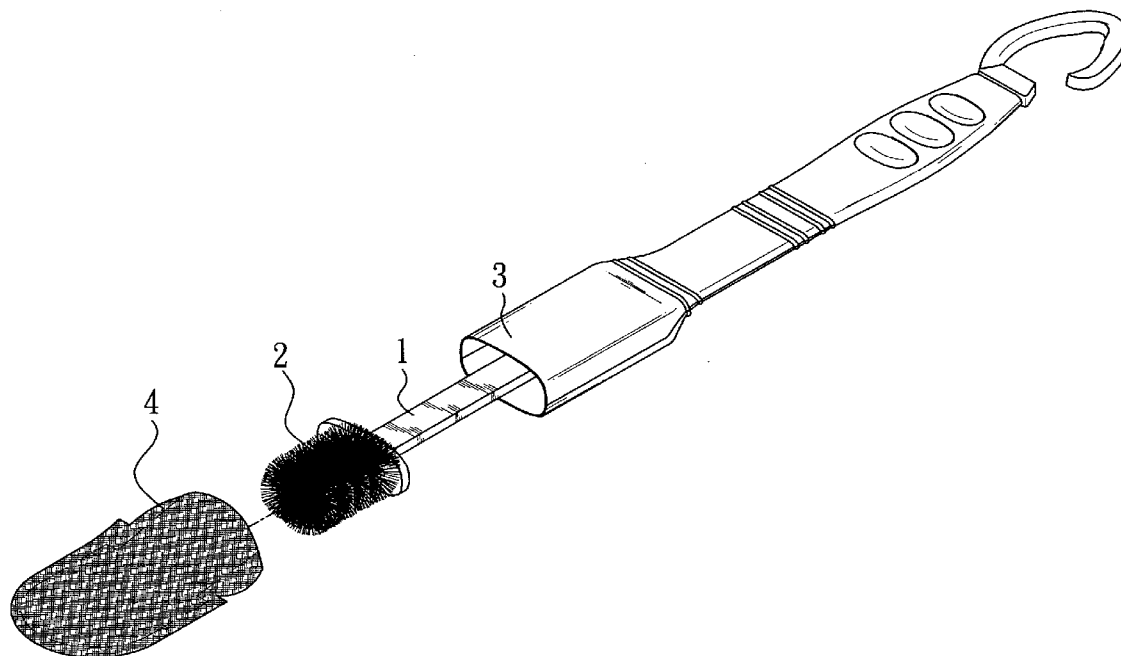

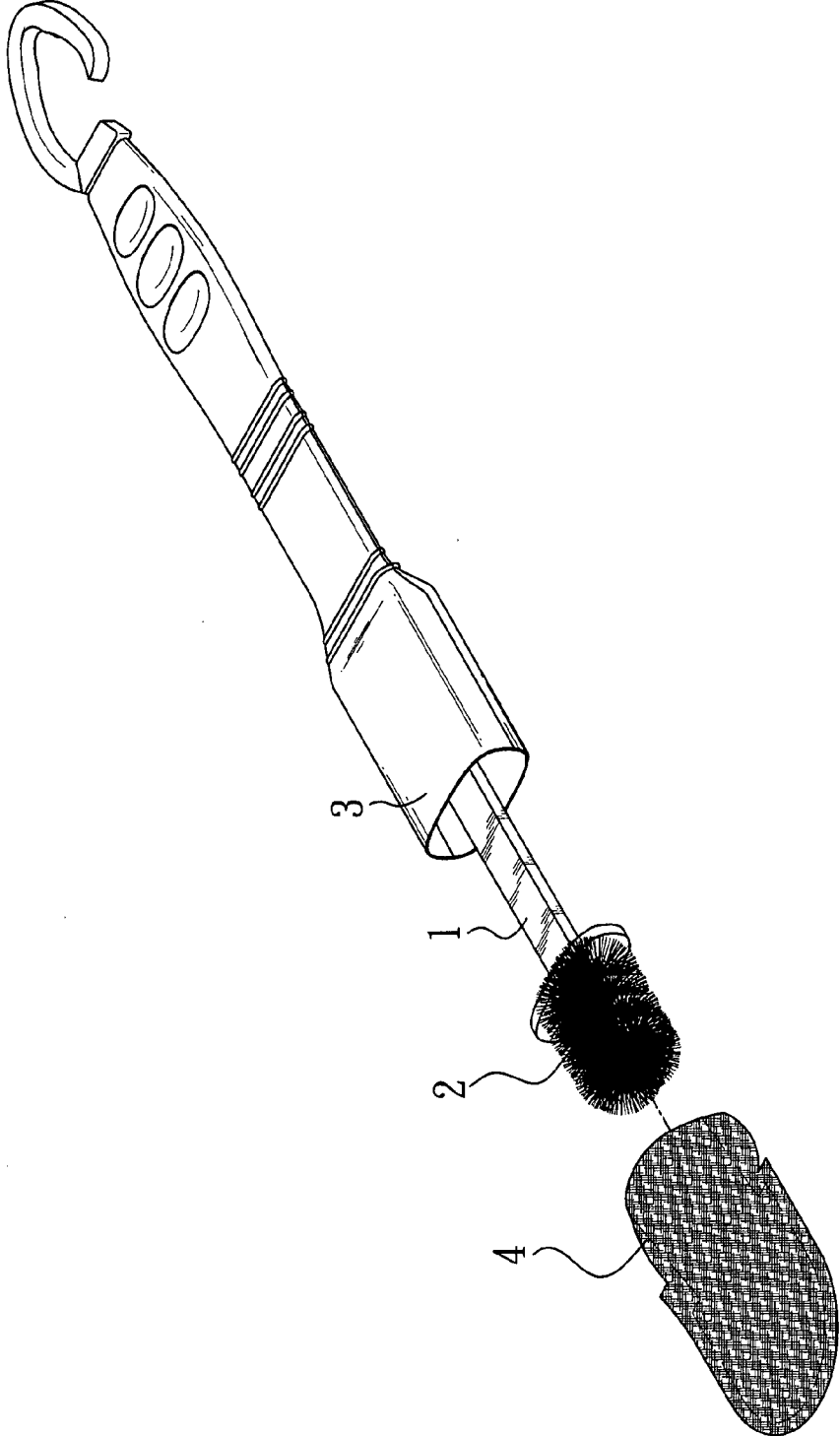

FIG. 1a

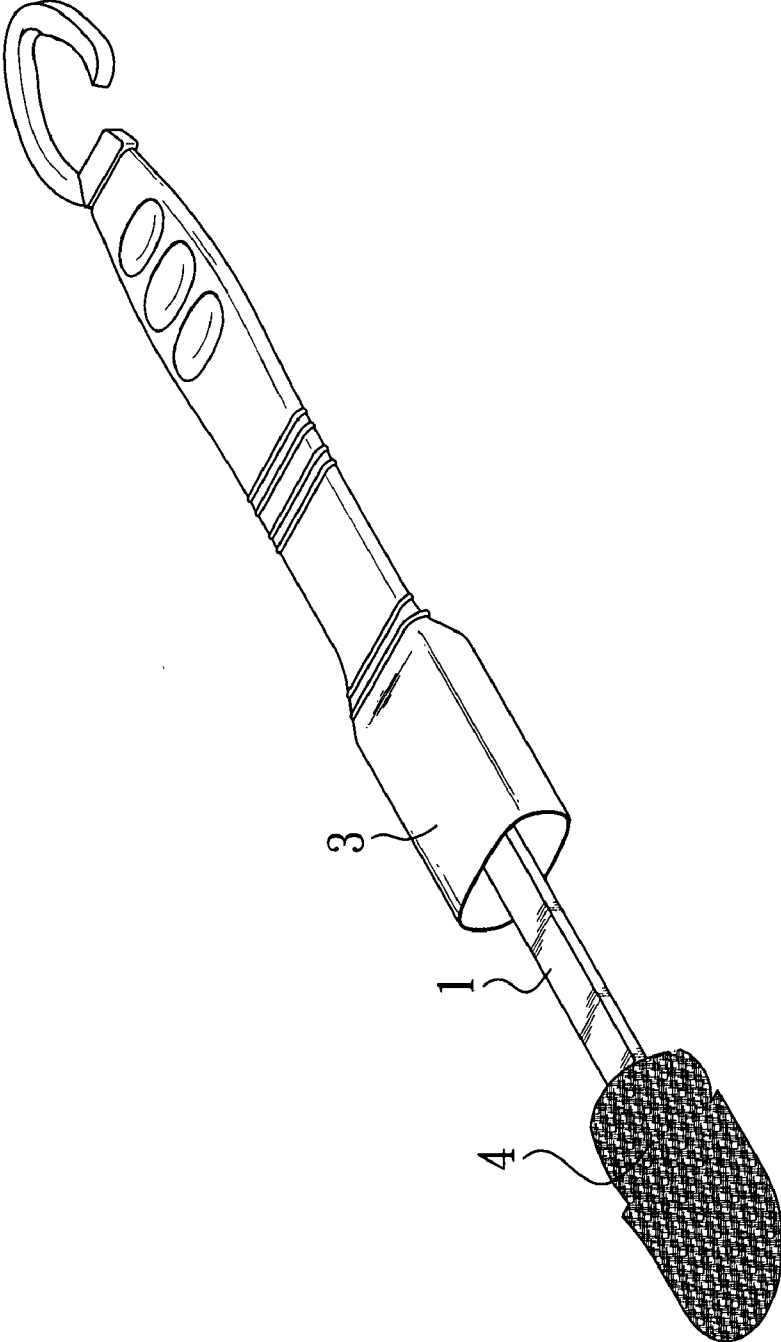

FIG. 1b

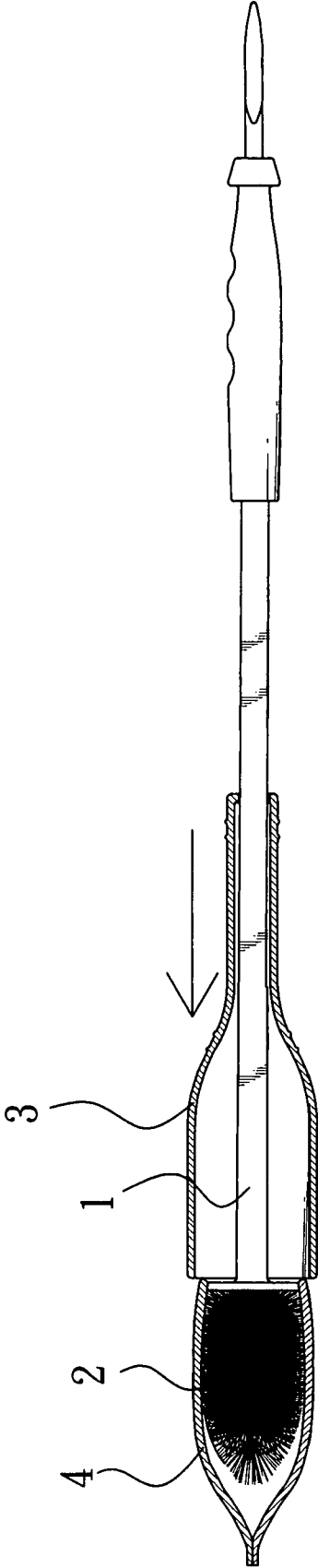

FIG. 2a

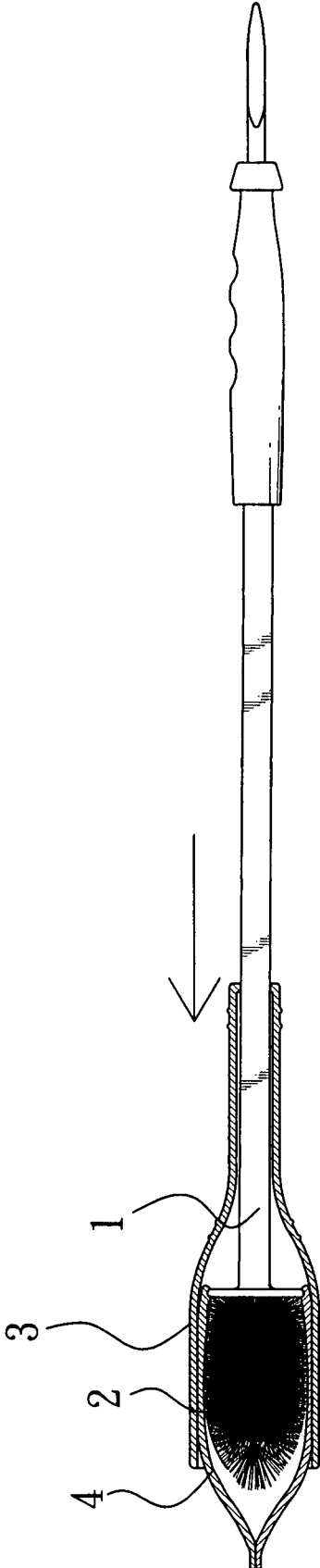

FIG. 2b

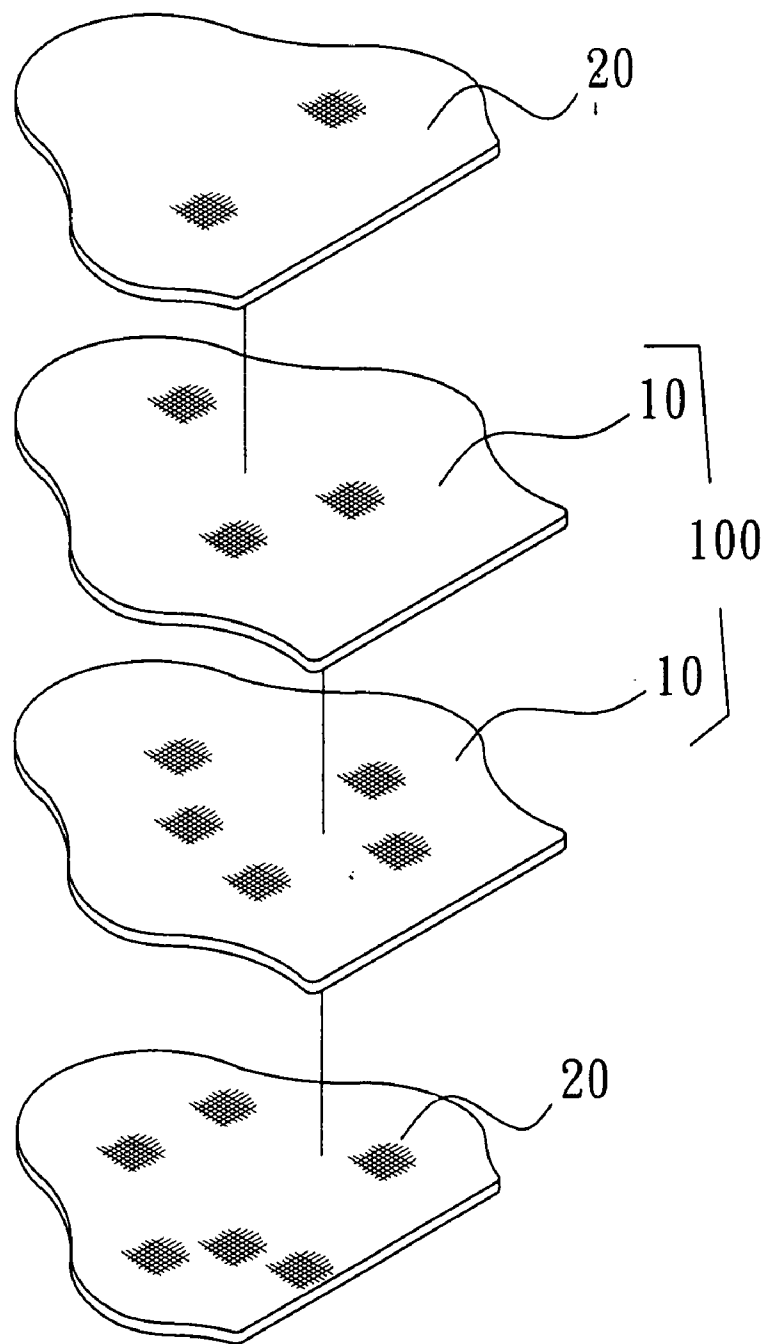

FIG. 3

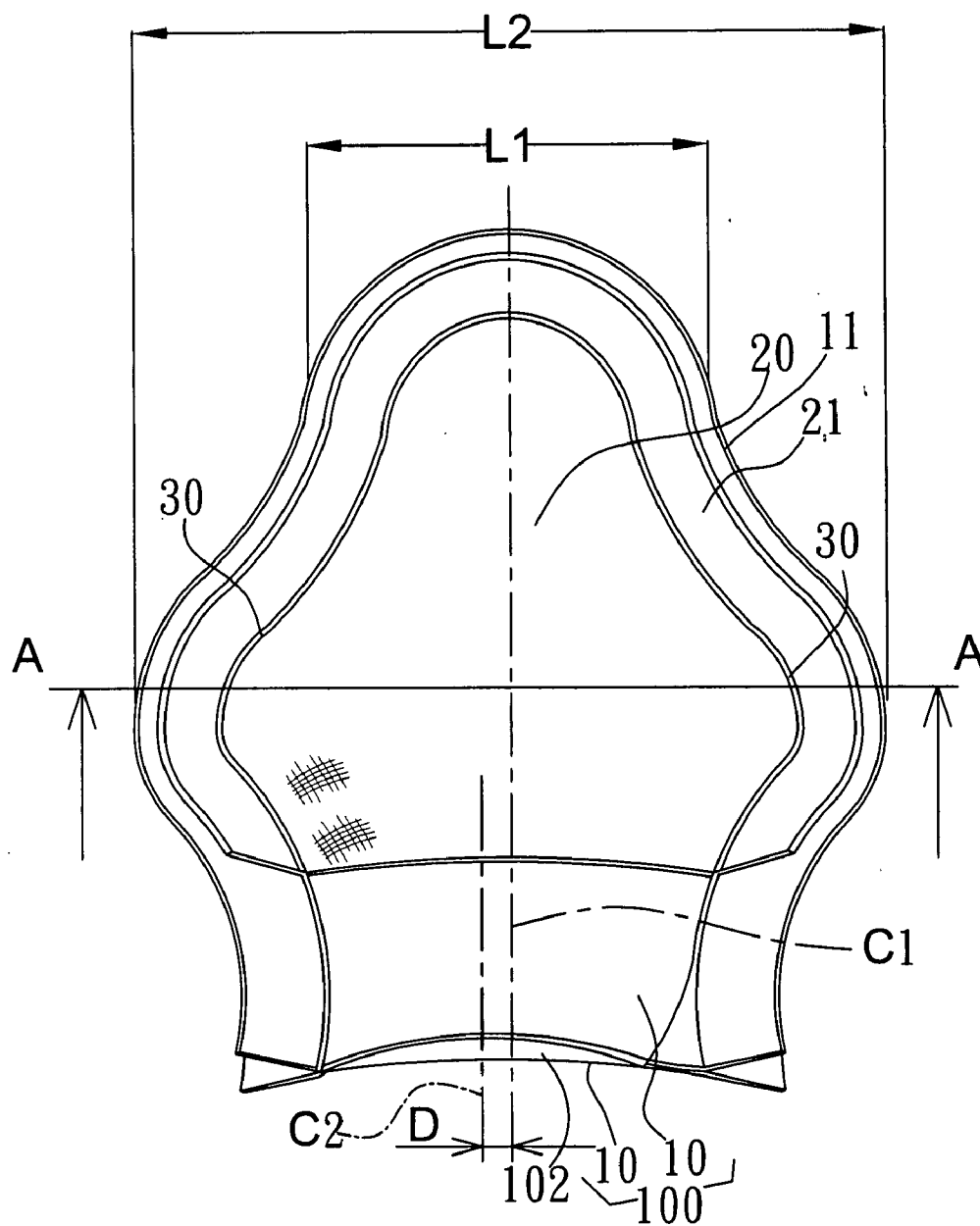

FIG. 4

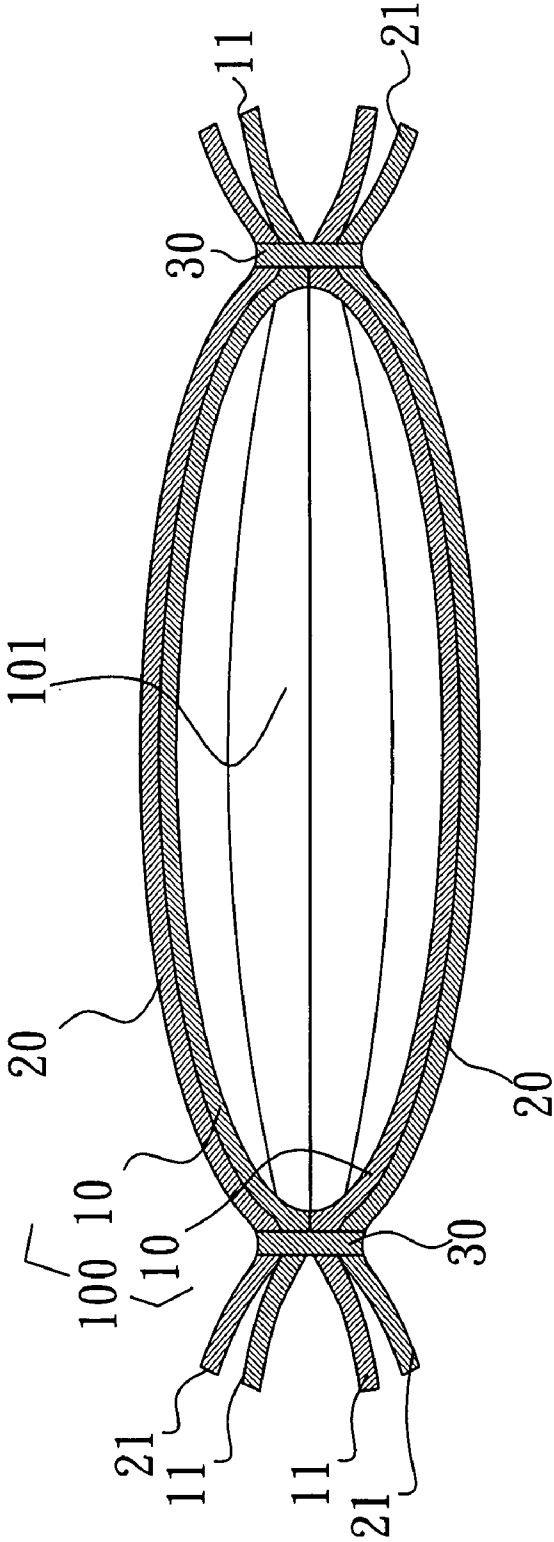

FIG. 5

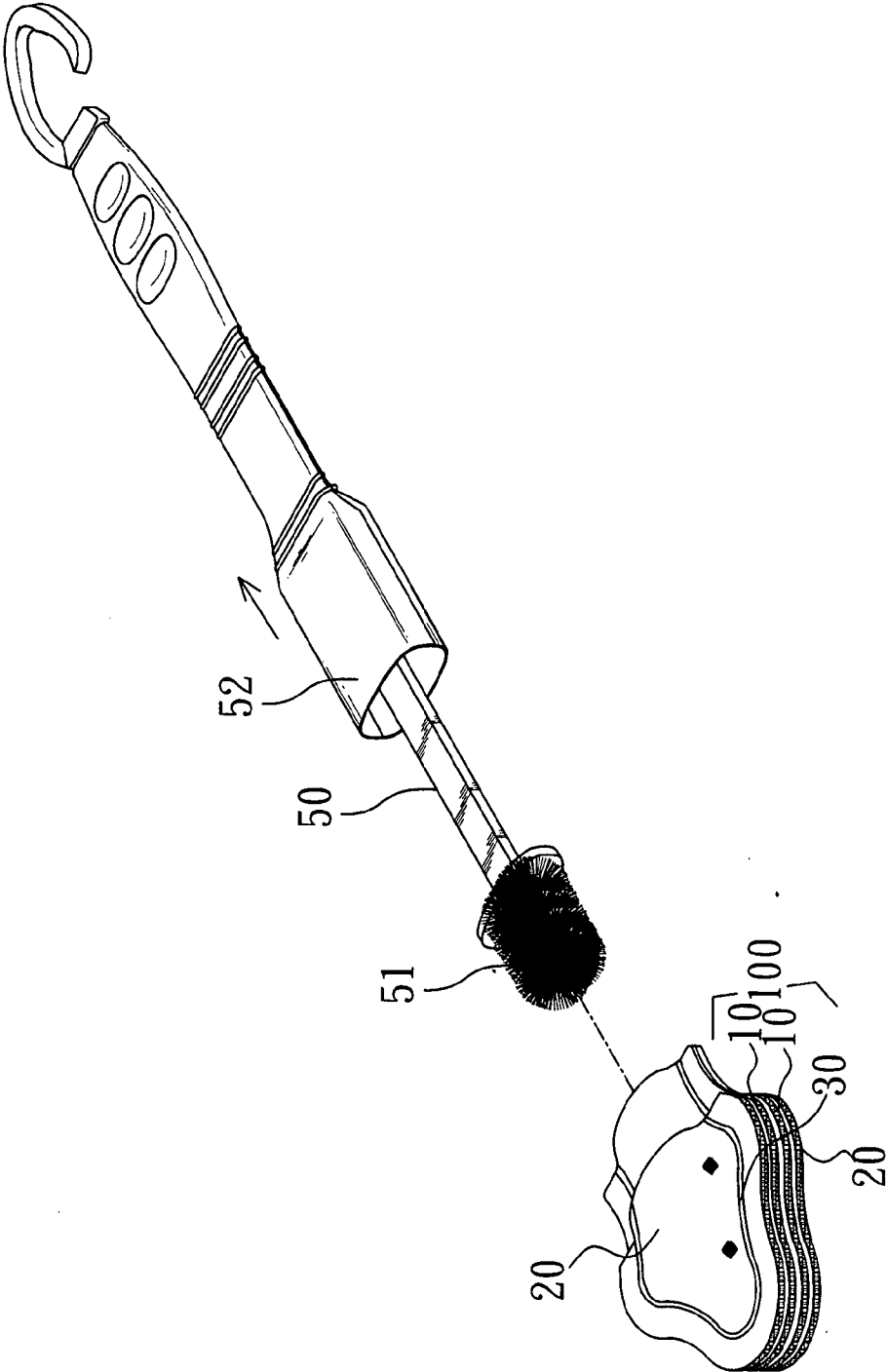

FIG. 6

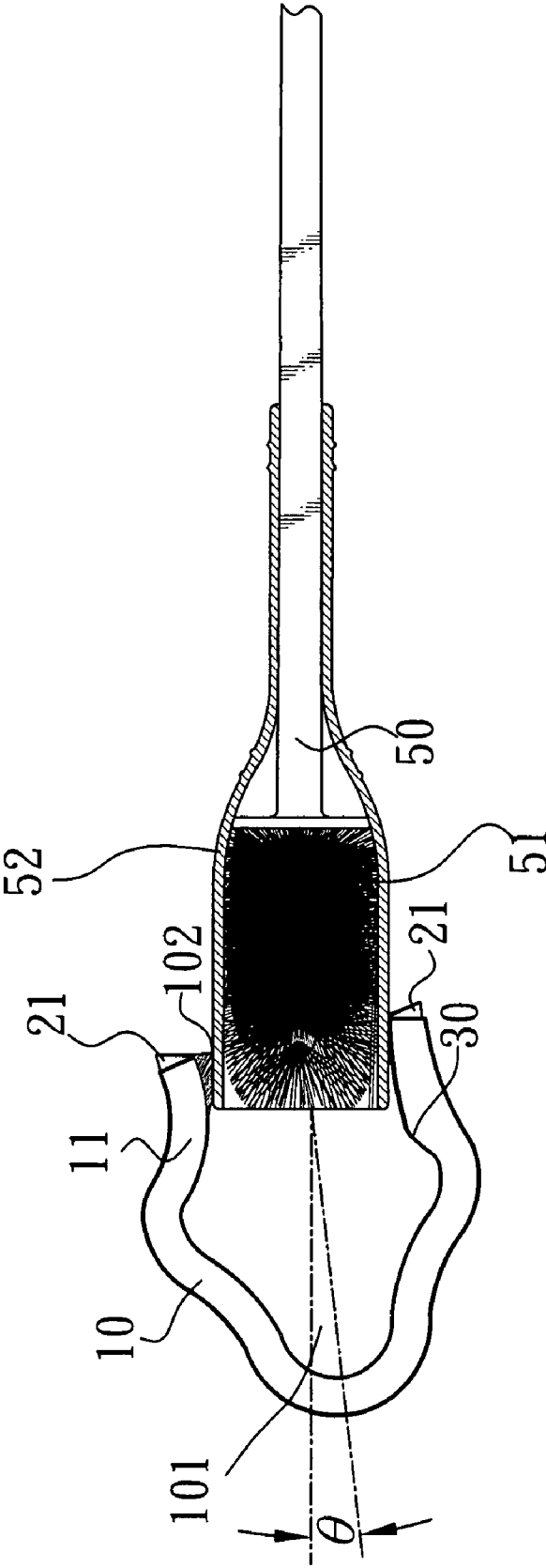

FIG. 7

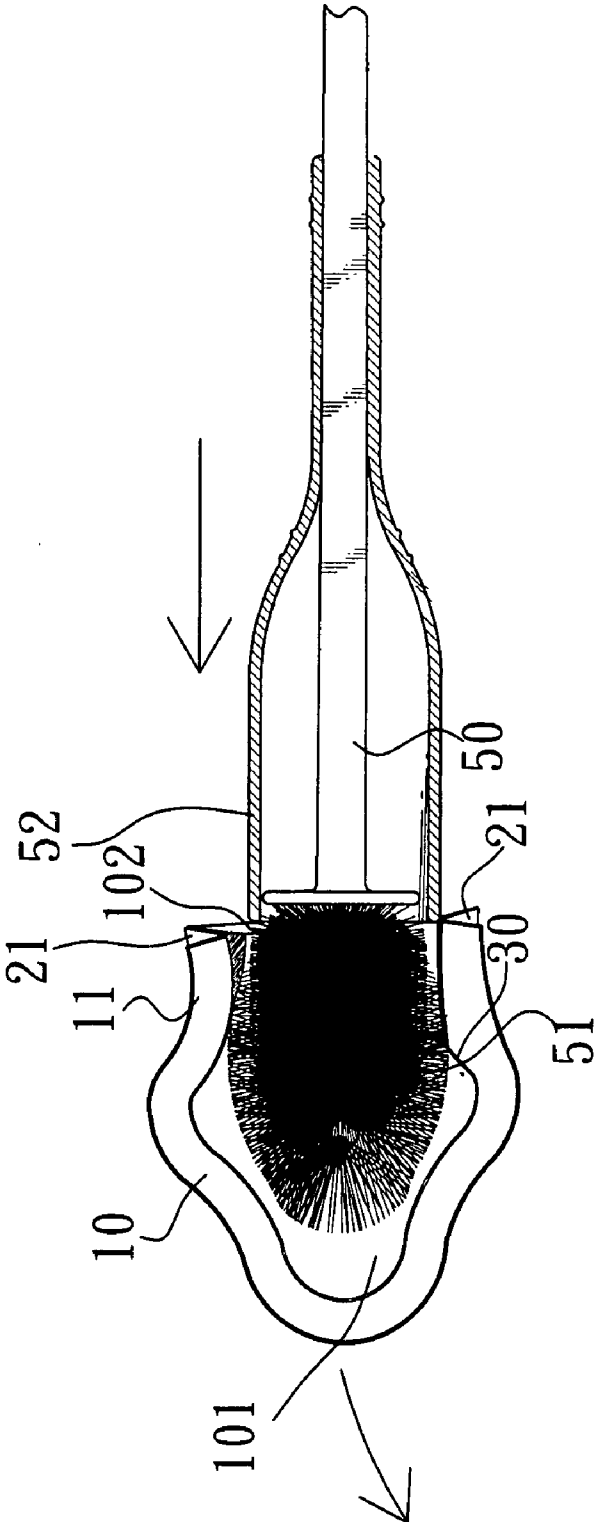

FIG. 8

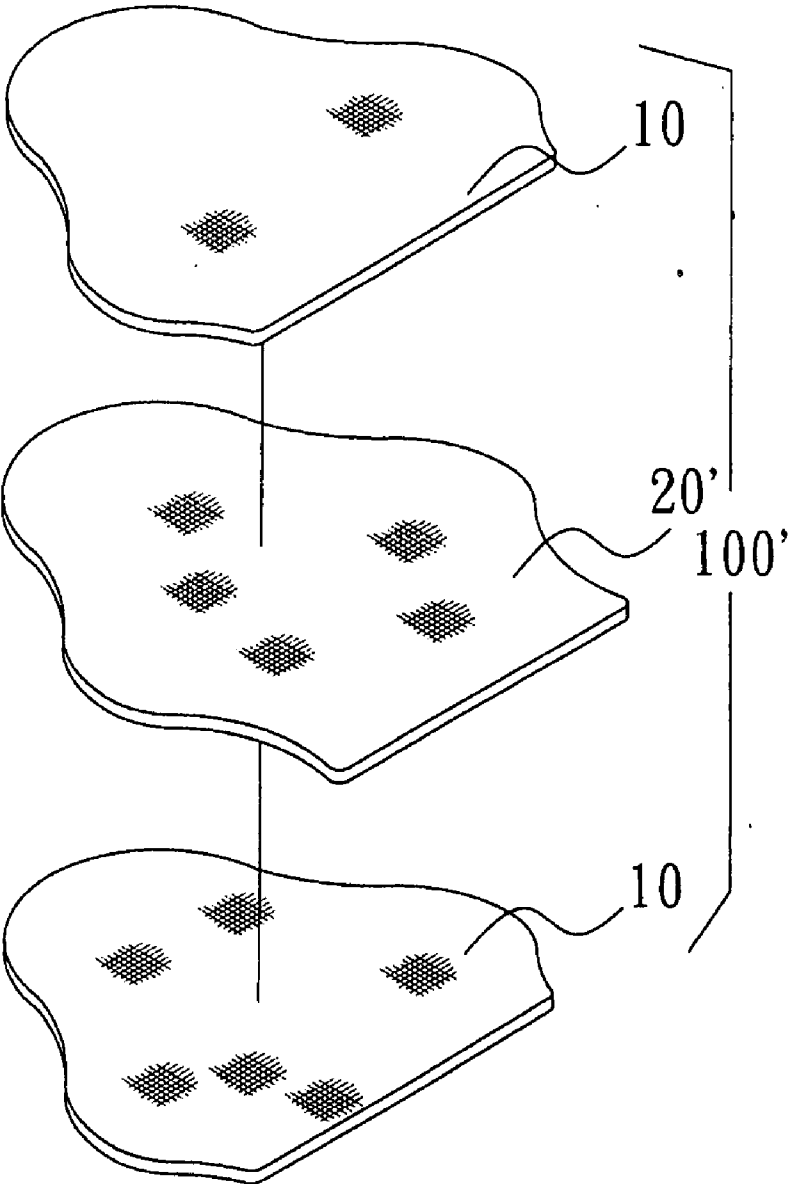

FIG. 9

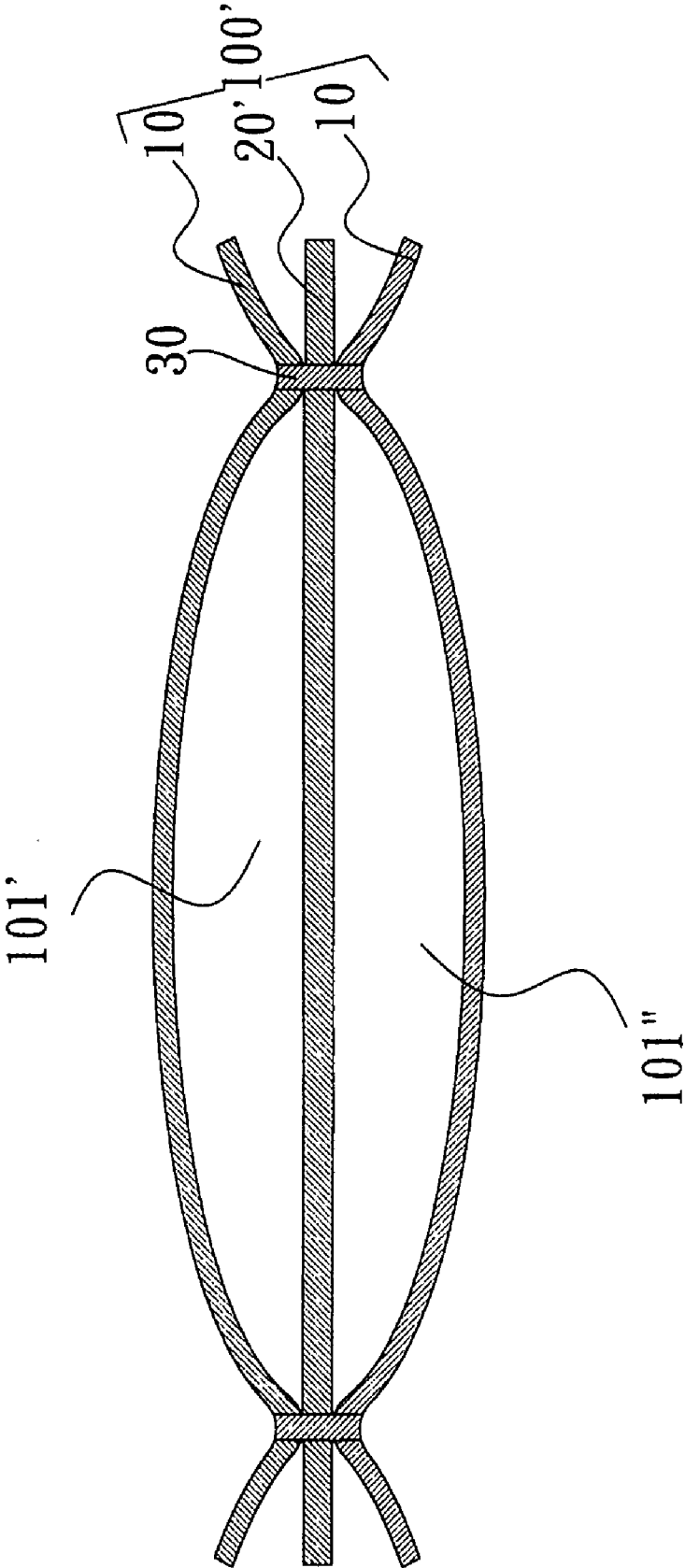

FIG. 10

CLEANING BRUSH CAP

BACKGROUND

[0001] 1. Technical Field

[0002] The present invention relates to a cleaning brush cap, in particular to a cleaning brush cap capable of cleaning small corners effectively and can be replaced easily.

[0003] 2. Related Art

[0004] The conventional brushes used for cleaning the bathroom, in particular the toilet brushes, only provide one single cleaning effect since they only have one single brush head. Therefore, it is necessary to prepare two toilet brushes with different brush heads for the bathroom, one of which comprises a sponge head and the other one comprises a stiff brush head, so as to achieve different effects. However, it would result in disorder in the bathroom due to existence of too many cleaning tools, and said sponge head also has the following drawbacks in view of long-term use:

[0005] 1. In practice, the sponge head provides the cleaning function only by scrubbing against the surface of the article to be cleaned with the surface (the outermost layer) of the sponge head. As a result, the sponge head should be made of high density sponge such that the sponge head may tightly fix to the front end of the stick of the cleaning brush, which leads to high production cost.

[0006] 2. Compared with the stiff brush head, the sponge head is less wear-resistant. Therefore, the user has to replace the sponge head frequently since the sponge head comes off the stick easily once it is damaged, which is not very useful.

[0007] 3. The sponge head tends to mildew and carry bacteria due to being in a humid environment for long. In addition, while changing the sponge head, it is necessary to remove the polluted sponge head by hand, which makes hands filthy easily and further influences personal hygiene.

[0008] Accordingly, the inventor of this application has proposed a two-way brush as shown in FIG. 1a, wherein the two-way brush comprises a stick 1 and a brush head 2 disposed on the front end of the stick 1, the middle portion of the stick 1 is covered with a movable sleeve 3, a bell-shaped opening for receiving the brush head 2 is disposed on the end of the movable sleeve 3 facing the brush head 2, and a cap 4 caps the brush head 2, as shown in FIG. 1b. The cap 4 is made of non-woven fabric to replace said sponge head, such that the two-way brush functions the same as the brush head 2 on one hand and functions the same as the conventional sponge head when being capped with the cap 4 of non-woven fabric on the other hand. Further, as shown in FIG. 2a, in the case of removing the cap 4 of non-woven fabric, the cap 4 of non-woven fabric may be removed from the brush head 2 by simply pushing the movable sleeve 3 from the middle portion toward the front end of the stick 1. Moreover, in the case of capping the brush head 2 with the cap 4 of non-woven fabric, the brush head 2 may be capped with the cap 4 of non-woven fabric by simply capping the movable sleeve 3 with the cap 4 and then pulling the movable sleeve 3 from the front end toward the middle portion of the stick 1 (not shown). The user's hand will not touch the brush head 2.

[0009] Although the aforementioned cap 4 may replace the sponge head, it still requires significant improvement in practice due to the following reasons: the conventional cap 4 of non-woven fabric is formed by stacking a plurality of non-woven fabric layers in the same shape and leaving a combination trace on the edge of the layers by heat fusing, such that

the layers are combined to form a cap for capping the brush head 2. However, the cap 4 is only adaptive to clean wide areas but not to clean small corners due to the thickness thereof, which is not very useful in practice.

[0010] In addition, when the cap 4 of non-woven fabric caps said two-way brush, the cap 4 tends to shrink into the movable sleeve 3 as shown in FIG. 2b due to the softness of the material, causing difficulty in removing the cap 4 from the brush head 2 by pushing the movable sleeve 3 from the middle portion toward the front end of the stick 1.

[0011] Thus, in order to overcome the drawbacks of prior art, the present invention is aimed at the improvement of the ability of the cap for cleaning small corners and how to remove the cap without difficulty.

SUMMARY OF THE INVENTION

[0012] In view of the foregoing, it is an objective of the present invention to provide a cleaning brush cap, wherein a margin is set between the combination trace and the edge of the cap such that the edge of each of the non-woven fabric layers becomes a loose border capable of cleaning small corners.

[0013] A further objective of the present invention is to provide a cleaning brush cap capable of taking away the filth, wherein the cleaning layers disposed on the surfaces of the cap are shorter in length so as to be distinguished from the main layers, whereby the brush head is inserted into the interior space of the cap body accurately.

[0014] A still further objective of the present invention is to provide a cleaning brush cap, wherein an eccentric distance D is set between the interior space of the cap and the centerline of the opening of the cap, such that a movable sleeve applies force to the cap appropriately to remove the cap.

[0015] A still further objective of the present invention is to provide a cleaning brush cap, wherein the cleaning layer is disposed on inner side of the cap body, such that a user's hand will not direct touch the cleaning layer.

[0016] In order to achieve the aforementioned objectives, the first embodiment of the present invention provides a cleaning brush cap comprising:

[0017] at least two main layers, superimposed to form a cap body having an interior space, wherein an opening is disposed on the lower end of the cap body such that a cleaning brush is inserted into the interior space through the opening;

[0018] at least two cleaning layers disposed on both surfaces of the cap body; and

[0019] at least one combination trace disposed on the surfaces of the cleaning layers for combining the main layers and the cleaning layers, wherein a margin is set between the combination trace and the edges of the layers, such that the edge of each of the layers forms a loose border capable of cleaning small corners.

[0020] In the aforementioned cleaning brush cap, an interior space is formed by the main layers to receive the cleaning brush, and the cleaning layers are for taking away the filth.

[0021] In the aforementioned cleaning brush cap, the cleaning layers are soaked in or sprayed with deodorizing or sterilizing detergent, and the cleaning brush cap is colored with pigment such that the timing for replacing the cleaning brush cap is indicated by the fading of the pigment.

[0022] In the aforementioned cleaning brush cap, the width of the front end of the cap is shorter than the width of the middle portion of the cap, whereby the front end of the cap with shorter width is employed for cleaning small corners

while the middle portion of the cap with greater width is employed for cleaning wide areas.

[0023] In the aforementioned cleaning brush cap, the shape of the cleaning layers corresponds to that of the main layers, and the cleaning layers are shorter than the main layers in length so as to be distinguished, whereby the brush head is inserted into the interior space of the cap body accurately.

[0024] The second embodiment of the present invention provides a cleaning brush cap comprising:

[0025] at least two main layers and one cleaning layer, the layers are superimposed to form a cap body having a first interior space and second interior space, wherein an opening is disposed on the lower end of the cap body such that a cleaning brush is inserted into one of the interior spaces through the opening; the cleaning layer is disposed on inner side of the cap body; and

[0026] at least one combination trace for combining the main layers and the cleaning layer, wherein a margin is set between the combination trace and the edges of the layers, such that the edge of each of the layers forms a loose border capable of cleaning small corners; and an eccentric distance D is provided between the middle section of the interior spaces and the opening,

[0027] With such a structure, the cleaning brush cap of the present invention may not only substitute for the conventional sponge head but also clean small corners effectively and can be replaced easily.

BRIEF DESCRIPTION OF THE DRAWINGS

[0028] FIG. 1a is an exploded view of the conventional two-way brush and the cleaning brush cap of non-woven fabric.

[0029] FIG. 1b is a schematic view showing the combination of the conventional two-way brush and the cleaning brush cap of non-woven fabric.

[0030] FIG. 2a is a cross-sectional view showing the combination of the conventional two-way brush and the cleaning brush cap of non-woven fabric.

[0031] FIG. 2b is a cross-sectional view showing the combination of the conventional two-way brush and the cleaning brush cap of non-woven fabric.

[0032] FIG. 3 is an exploded view of the cleaning brush cap of the first embodiment of the present invention.

[0033] FIG. 4 is a top view of the cleaning brush cap of the first embodiment of the present invention.

[0034] FIG. 5 is a cross-sectional view taken along the line A-A in FIG. 4.

[0035] FIG. 6 is an exploded view showing the combination of the cleaning brush cap of the first embodiment of the present invention and the conventional two-way brush.

[0036] FIG. 7 is a cross-sectional view showing the combination of the cleaning brush cap of the first embodiment of the present invention and the conventional two-way brush in the case where the cleaning brush cap caps the brush head of the two-way brush.

[0037] FIG. 8 is a cross-sectional view showing the combination of the cleaning brush cap of the first embodiment of the present invention and the conventional two-way brush in the case where the cleaning brush cap is removed from the brush head by the movable sleeve.

[0038] FIG. 9 is an exploded view of the cleaning brush cap of the second embodiment of the present invention.

[0039] FIG. 10 is a cross-sectional view of the cleaning brush cap of the second embodiment of the present invention.

DETAILED DESCRIPTION

[0040] In consideration of the techniques employed to achieve the above objectives and the effects of the present invention, preferred embodiments will be described hereinafter with reference to the appended drawings.

[0041] Although the cleaning brush cap of the present invention is embodied by capping a toilet brush, the usage and the implementing occasion thereof are not limited. Similarly, the structure and the material of the cleaning brush mentioned herein is not limited either, as long as the cleaning brush comprises a stick and a brush head fixed on one end of the stick. The present invention is mainly embodied with a conventional two-way brush, wherein the two-way brush comprises a stick 50, a brush head 51 on the front end of the stick 50, and a movable sleeve 52 covering and sliding over the stick 50, as shown in FIG. 6. And, the layers of the present invention are made of same material and can be exchanged in spite of they have different functional name.

[0042] Please refer to FIGS. 3 to 8. As shown, in the first embodiment of the present invention the cleaning brush cap comprises: at least two main layers 10, at least two cleaning layers 20, and at least one combination trace 30; wherein the main layers 10 are superimposed together in order to form a cap body 100, and the cleaning layers 20 are disposed on both surfaces of the cap body 100; wherein the cap body 100 includes an interior space 101, and an opening 102 is disposed on the lower end of the cap body 100 such that the brush head 51 of the cleaning brush can be inserted into the interior space 101 through the opening 102.

[0043] The cleaning layers 20 disposed on the outer surfaces of the cap body 100 provide the function of taking away the filth by scrubbing against the surface of the article to be cleaned. Therefore, the cleaning layers 20 may be soaked in or sprayed with deodorizing or sterilizing detergent in advance to enhance the cleaning effect. The cleaning brush cap may also be colored with pigment such that the timing for replacing the cleaning brush cap is indicated by the fading of the pigment. The shape of the cleaning layers corresponds to that of the cap body 100; however, the cleaning layers 20 are shorter than the main layers 10 in length so as to be distinguished from the main layers 10, whereby the brush head 51 is inserted through the opening 102 of the cap body 100 accurately. And, the chemical fiber employed by the cleaning layers 20 is between 2.0 and 50 denier.

[0044] The combination trace 30 is disposed on the surfaces of the cleaning layers 20 for combining the main layers 10 and the cleaning layers 20, and a margin is set between the combination trace 30 and the edges of the aforementioned layers (in this embodiment, the margin is 0.5 cm), such that the edge of each of the layers (the main layers 10 and the cleaning layers 20) forms loose borders 11, 21 (as shown in FIG. 4) capable of cleaning small corners effectively. In this embodiment, the combination trace 30 is mainly formed by heat fusing to combine the cleaning layers 20 and the main layers 10. However, the present invention is not limited to employ heat fusing.

[0045] Referring to FIG. 4 again, the width L1 of the front end of the cap body 100 is shorter than the width L2 of the middle portion of the cap body 100, whereby the front end of the cap with shorter width is employed for cleaning small

corners while the middle portion of the cap with greater width is employed for cleaning wide areas.

[0046] Please refer to FIG. 4 and FIGS. 7 to 8 again. As shown, when the cleaning brush cap of the present invention caps the brush head 51 of the conventional two-way brush having a movable sleeve 52, in order to remove the cleaning brush cap from the brush head 51 effectively without physical touch by the movable sleeve 52, an eccentric distance D is set between the centerline C1 of the interior space 101 of the cap body 100 and the centerline C2 of the opening 102 of the cap body 100, such that when the brush head 51 of the two-way brush is to be capped with the cleaning brush cap, a relative shift angle θ is generated (as shown in FIG. 7) to make a part of the opening 102 of the cleaning brush cap correspond to the front end of the movable sleeve 52. More specifically, the greater the eccentric distance D between the centerlines C1 and C2 is, the greater the shift angle θ generated by the cleaning brush cap will be. Hence, when the movable sleeve 52 of the two-way brush is pushed from the middle portion toward the front end of the stick 50, the cleaning brush cap is removed from the brush head 51 due to the force applied to the edge of the opening 102 of the cleaning brush cap by the edge of the movable sleeve 52 (as shown in FIG. 8).

[0047] Please refer to FIGS. 4, 9 and 10. The second embodiment of the present invention is mainly the same as the first one except the number of the layers and the arrangement of the cleaning layer 20' are different from that of the first embodiment of the present invention. The second embodiment of the present invention provides a cleaning brush cap comprising:

[0048] at least two main layers 10 and one cleaning layer 20', the layers are superimposed to form a cap body 100' having a first interior space 101' and a second interior space 101'' (as shown in FIG. 10), wherein an opening 102 is disposed on the lower end of the cap body 100' such that a cleaning brush 51 is inserted into the interior spaces 101' or 101'' through the opening 102; the cleaning layer 20' is disposed on inner side of the cap body 100';

[0049] Furthermore, the cleaning layer 20' of the second embodiment of the present invention is not limited in single layer and the thick of the cleaning layer 20' can be adjusted depends on the volume of the deodorizing or sterilizing detergent needed.

[0050] While this invention has been described in terms of several preferred embodiments, there are alterations, permutations, and various substitute equivalents, which fall within the scope of this invention. It should also be noted that there are many alternative ways of implementing the methods and apparatuses of the present invention.

What is claimed is:

1-10. (canceled)

11. A cleaning brush cap, comprising:

at least two main layers, which are superimposed to form a cap body having an interior space, wherein an opening is disposed on one end of the cap body such that the brush head of a cleaning brush is inserted into the interior space through the opening;

at least two cleaning layers disposed on both surfaces of the cap body; and

at least one combination trace disposed on surfaces of the cleaning layers for combining the main layers and the cleaning layers, wherein a margin is set between the combination trace and an edge of the cleaning layers, and an eccentric distance is provided between the middle section of the interior space and the opening.

12. A cleaning brush cap, comprising:

at least two main layers and one cleaning layer, the layers are superimposed to form a cap body having a first interior space and second interior space, wherein an opening is disposed on the lower end of the cap body such that a cleaning brush is inserted into one of the interior spaces through the opening; the cleaning layer is disposed on inner side of the cap body; and

at least one combination trace for combining the main layers and the cleaning layer, wherein a margin is set between the combination trace and the edges of the layers, such that the edge of each of the layers forms a loose border; and an eccentric distance is provided between the middle section of the interior space and the opening.

13. The cleaning brush cap according to claims 11 or 12, wherein the main layers and the cleaning layer are made of non-woven fabric and the fiber of the cleaning layer is between 2.0 and 50 denier; the cleaning layer is soaked in or sprayed with deodorizing or sterilizing detergent.

14. The cleaning brush cap according to claims 11 or 12, wherein width of one end of the cap body is shorter than width of the middle portion of the cap body, and the shape of the cleaning layer corresponds to that of main layers, and the cleaning layer is shorter than the main layers in length; the combination trace is performed by heat fusing; and the cleaning brush cap is colored with pigment such that timing for replacing the cleaning brush cap is indicated by fading state of the pigment.

15. The cleaning brush cap according to claims 11 or 12, wherein the margin is 0.5 cm or more.

* * * * *