

(12) STANDARD PATENT
(19) AUSTRALIAN PATENT OFFICE

(11) Application No. **AU 2017443355 B2**

(54) Title
A shelf assembly

(51) International Patent Classification(s)
A47F 5/00 (2006.01) **A47B 57/26** (2006.01)
A47B 49/00 (2006.01) **A47B 88/48** (2017.01)

(21) Application No: **2017443355** (22) Date of Filing: **2017.12.18**

(87) WIPO No: **WO19/120465**

(43) Publication Date: **2019.06.27**

(44) Accepted Journal Date: **2024.03.14**

(71) Applicant(s)
EasyFill AB (publ)

(72) Inventor(s)
BERSAGEL, Henning;SJÖLANDER, Håkan

(74) Agent / Attorney
WRAYS PTY LTD, L7 863 Hay St, Perth, WA, 6000, AU

(56) Related Art
EP 2091391 B1



(51) International Patent Classification:

A47F 5/00 (2006.01) A47B 57/26 (2006.01)
A47B 49/00 (2006.01) A47B 88/48 (2017.01)

(21) International Application Number:

PCT/EP2017/083221

(22) International Filing Date:

18 December 2017 (18.12.2017)

(25) Filing Language:

English

(26) Publication Language:

English

(71) Applicant: **EASYFILL AB (PUBL)** [SE/SE]; Industriegatan 10, 840 60 Bräcke (SE).

(72) Inventors: **BERSAGEL, Henning**; Lyngnesveien 35, 4018 Stavanger (NO). **SJÖLANDER, Håkan**; Box 153, 840 60 Bräcke (SE).

(74) Agent: **AWA SWEDEN AB**; Box 665, 831 27 Östersund (SE).

(81) Designated States (unless otherwise indicated, for every kind of national protection available): AE, AG, AL, AM, AO, AT, AU, AZ, BA, BB, BG, BH, BN, BR, BW, BY, BZ, CA, CH, CL, CN, CO, CR, CU, CZ, DE, DJ, DK, DM, DO, DZ, EC, EE, EG, ES, FI, GB, GD, GE, GH, GM, GT, HN, HR, HU, ID, IL, IN, IR, IS, JO, JP, KE, KG, KH, KN, KP, KR, KW, KZ, LA, LC, LK, LR, LS, LU, LY, MA, MD, ME,

MG, MK, MN, MW, MX, MY, MZ, NA, NG, NI, NO, NZ, OM, PA, PE, PG, PH, PL, PT, QA, RO, RS, RU, RW, SA, SC, SD, SE, SG, SK, SL, SM, ST, SV, SY, TH, TJ, TM, TN, TR, TT, TZ, UA, UG, US, UZ, VC, VN, ZA, ZM, ZW.

(84) Designated States (unless otherwise indicated, for every kind of regional protection available): ARIPO (BW, GH, GM, KE, LR, LS, MW, MZ, NA, RW, SD, SL, ST, SZ, TZ, UG, ZM, ZW), Eurasian (AM, AZ, BY, KG, KZ, RU, TJ, TM), European (AL, AT, BE, BG, CH, CY, CZ, DE, DK, EE, ES, FI, FR, GB, GR, HR, HU, IE, IS, IT, LT, LU, LV, MC, MK, MT, NL, NO, PL, PT, RO, RS, SE, SI, SK, SM, TR), OAPI (BF, BJ, CF, CG, CI, CM, GA, GN, GQ, GW, KM, ML, MR, NE, SN, TD, TG).

Published:

— with international search report (Art. 21(3))

(54) Title: A SHELF ASSEMBLY

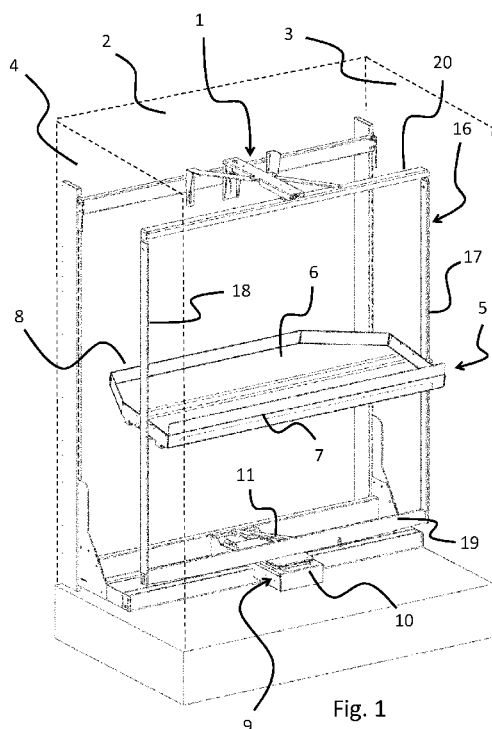

(57) Abstract: A shelf assembly (1) for products comprising a shelving section (5) with at least one shelf (6), which is rotatable about an axis of rotation (13) between a display position, in which the shelf is accessible from the front (7) of the shelving section, and a refill position, in which the shelf is accessible from the rear (8) of the shelving section. The shelf assembly further comprises a support (9), which has a sledge (10) rotatably supporting the shelving section, and being movable in a forward-rearward direction. When the shelving section is rotated from the display position to the refill position, the sledge is first moved forwards, and then rearwards back to its starting position. The shelving section further comprises a frame (16) having opposite first and second side posts (17, 18), wherein the shelf is mounted between the side posts at an arbitrary height. The shelf is provided with a respective clamping portion at opposite ends of the shelf, fixing the shelf at the side posts. Each clamping portion comprises a hook portion engaged with a respective side post at a first surface thereof, and a tightening portion engaged with an opposite second surface of the side post, wherein the tightening portion is untightenable for arbitrary height movement of the shelf.



A SHELF ASSEMBLY

Field of the Invention

2017443355 29 Feb 2024
5 The present invention relates generally to a shelf assembly with shelves for products. The shelf assembly is arranged to be placed in a limited space, and is rotatable between at least one display position, in which the shelves are accessible from the front of the shelving section, and a refill position, in which the shelves are accessible from the rear of the shelving section.

Background of the Invention

10 In supermarkets and department stores there are many different types of shelf assemblies, which are filled with products offered for sale. Many of these products must for various reasons, such as open-dating or refrigerating reasons, be supplied in such a manner that the last supplied products are positioned in the rear part of the shelf. At the same time this satisfies the requirement that the product first supplied is also first sold. The rotatable shelf assembly satisfies these needs, and also facilitates the operation of
15 refilling the shelves with further products when they start to become empty. EP2091391 discloses a prior art shelf assembly of this kind.

However, the shelf assembly of EP2091391 has generated a demand for further simplified refilling operations.

It is against this background that the present invention has been developed.

20 The preceding discussion of the background art is intended to facilitate an understanding of the present invention only. The discussion is not an acknowledgement or admission that any of the material referred to is or was part of the common general knowledge as at the priority date of the application.

Summary of the Invention

25 It would be advantageous to simplify the refilling operation. To better address this concern, in a first aspect of the invention there is presented a shelf assembly for products to be placed in a space, which at least is limited in depth by a rear boundary surface and laterally by lateral boundary surfaces, the shelf assembly having a shelving section with a front and a rear, which shelving section comprises a shelf, the shelving section being

rotatable about an axis of rotation between a display position, in which the shelf is accessible from the front of the shelving section, and a refill position, in which the shelf is accessible from the rear of the shelving section, wherein the shelf assembly further comprises a support, which comprises a sledge rotatably supporting the shelving section, and being movable in depth of the space, in a forward-rearward direction, and an arm having a first end pivotally connected with the shelving section at a bottom end thereof, at a distance from the axis of rotation, and having a second end pivotally connected with a fixed portion of the support, such that when the shelving section is rotated from the display position to the refill position, due to the arm, which is pivoting during the rotation, the sledge is first moved forwards a distance from a starting position, and then rearwards back to its starting position, and wherein the shelving section further comprises a frame having opposite first and second side posts, wherein the shelf is mounted between the side posts at an arbitrary height, wherein the shelf is provided with a respective clamping portion at opposite ends of the shelf, wherein the clamping portions fix the shelf at the side posts, wherein each clamping portion comprises a hook portion engaged with a respective side post at a first surface thereof, and a tightening portion engaged with an opposite second surface of the side post, whereby the side post is clamped between the hook portion and the tightening portion, and wherein the tightening portion is untightenable for arbitrary height movement of the shelf.

The combination of a rotation solution where the shelving section does not protrude more from the space in the refill position than in the display position, contrary to the shelving section of the above-mentioned prior art, and the shelf, or shelves, being arbitrarily height adjustable does indeed simplify the refilling operation.

In accordance with an embodiment of the shelf assembly, the shelf comprises an end plate at each end thereof, wherein the clamping portion is attached to the end plate, wherein the hook portion and the tightening portion are attached to the end plate with a mutual spacing, and wherein the hook portion comprises a first edge surface protruding from the end plate and being engaged with the first surface of the side post, and a second edge surface extending perpendicular to the first edge surface and being engaged with a third surface of the side post extending perpendicular to and adjacent to the first surface. Thereby the hook portions advantageously grip around a respective corner of each side post, and fixes the lateral position of the shelf.

In accordance with an embodiment of the shelf assembly, the tightening portion comprises a nut attached to the side plate, and a screw arranged at the nut, protruding from the nut towards the hook portion and being engaged with the second surface of the side post, wherein the screw is arranged to be loosened to untighten the tightening portion. The nut and screw is classic per se, but is advantageously simple in this context.

In accordance with an embodiment of the shelf assembly, the sledge is provided with wheels at an underside of the sledge, which wheels are running in guide tracks. Thereby the reciprocating movement of the sledge in the forward-rearward direction is well controlled, and the shelving section is moved with low friction and low force.

In accordance with an embodiment of the shelf assembly, it comprises a top holder, wherein the top of the shelving section is rotationally connected with a top holder, which top holder struts the shelving section.

In accordance with an embodiment of the shelf assembly, the top holder comprises a telescoping beam rotationally connected with the shelving section at a top thereof and telescoping forward and rearward, and wherein the telescoping beam is moving in a housing, which is a fixed part of the shelf assembly.

According to a first aspect of the invention there is provided a shelf assembly for displaying products, the shelf assembly configured to be placed in a space limited in depth by a rear boundary surface and laterally by lateral boundary surfaces, the shelf assembly having a shelving section with a front and a rear, which shelving section comprises a shelf, the shelving section being rotatable about an axis of rotation between a display position, in which the shelf is accessible from the front of the shelving section, and a refill position, in which the shelf is accessible from the rear of the shelving section, wherein the shelf assembly further comprises a support, which comprises a sledge rotatably supporting the shelving section, and being movable in depth of the space, in a forward-rearward direction, and an arm having a first end pivotally connected with the shelving section at a bottom end thereof, at a distance from the axis of rotation, and having a second end pivotally connected with a fixed portion of the support, such that when the shelving section is rotated from the display position to the refill position, due to the arm, which is pivoting during the rotation, the sledge is first moved forwards a distance from a starting position, and then rearwards back to its starting position, and wherein the shelving section further comprises a frame having opposite first and second side posts,

wherein the shelf is mounted between the side posts at an arbitrary height, wherein the shelf is provided with a respective clamping portion at opposite ends of the shelf, wherein the clamping portions fix the shelf at the side posts, wherein each clamping portion comprises a hook portion engaged with a respective side post at a first surface thereof, and a tightening portion engaged with an opposite second surface of the side post, whereby the side post is clamped between the hook portion and the tightening portion, and wherein the tightening portion is untightenable for arbitrary height movement of the shelf.

Preferably, the shelf comprises an end plate at each end thereof, wherein the clamping portion is attached to the end plate, wherein the hook portion and the tightening portion are attached to the end plate with a mutual spacing, and wherein the hook portion comprises a first edge surface protruding from the end plate and being engaged with the first surface of the side post, and a second edge surface extending perpendicular to the first edge surface and being engaged with a third surface of the side post extending perpendicular to and adjacent to the first surface.

Preferably, the tightening portion comprises a nut attached to the end plate, and a screw arranged at the nut, protruding from the nut towards the hook portion and being engaged with the opposite second surface of the side post, wherein the screw is arranged to be loosened to untighten the tightening portion.

Preferably, the sledge is provided with wheels at an underside of the sledge, which wheels are running in guide tracks.

Preferably, the shelf assembly comprises a top holder, wherein the top of the shelving section is rotationally connected with a top holder, which top holder struts the shelving section.

Preferably, the top holder comprises a telescoping beam rotationally connected with the shelving section at a top thereof and telescoping forward and rearward, and wherein the telescoping beam is moving in a housing, which is a fixed part of the shelf assembly.

Brief Description of the Drawings

Further features of the present invention are more fully described in the following description of several non-limiting embodiments thereof. This description is included

solely for the purposes of exemplifying the present invention. It should not be understood as a restriction on the broad summary, disclosure or description of the invention as set out above. The description will be made with reference to the accompanying drawings in which:

5 Fig. 1 shows a schematic perspective view of an embodiment of the shelf assembly according to the present invention mounted in a space;

Figs. 2-6 schematically illustrate the operation of rotating a shelving section of the shelf assembly; and

10 Figs. 7-8 show schematic perspective views of a part of a shelf of the shelf assembly.

In the drawings like structures are referred to by like numerals throughout the several views. The drawings shown are not necessarily to scale, with emphasis instead generally being placed upon illustrating the principles of the present invention.

Description Of Embodiments

15 As shown in Fig. 1 an embodiment of the shelf assembly 1 according to the present invention arranged in a space defined by a rear wall 2, providing a rear boundary surface, and side walls 3, 4, providing lateral boundary surfaces, attached to the rear wall 2 at its side edges. The rear and side walls 2-4 are merely schematically shown and in practice they can be walls of any kind, such as fixed walls of a room, walls of a cooler or freezer
20 of a store, walls of a freestanding goods shelf, etc. The shelf assembly comprises a shelving section 5 having at least one shelf 6. Usually the shelving section 5 comprises several vertically spaced-apart shelves 6, but single shelf alternatives are also encompassed by this application. The shelving section 5 has a front 7 and a rear 8, and is rotatable about an axis of rotation between at least one display position, shown in
25 Fig. 1, in which the shelf is accessible from the front of the shelving section, and a refill position, in which the shelf is accessible from the rear 8 of the shelving section 5. Preferably, the shelves 6 are of a gravity-feeding kind. The term gravity-feeding means that the shelves 6 are slopingly mounted and provided with a surface that allows the products placed on the shelves 6 to move forwards and downwards along the surface
30 towards the opening of the space, as known per se from the prior art. The shelf assembly 1 further comprises a support 9, which comprises a sledge 10 rotatably supporting the

2017443355
29 Feb 20242017443355
29 Feb 2024

shelving section 5, and being movable in depth of the space, in a forward-rearward direction, i.e. in a reciprocating movement towards the front opening of the space and towards the rear wall 2. The shelving section 5 further comprises a frame 16 having opposite spaced apart first and second side posts 17, 18 one of which is visible in the figures, a bottom bar 19, and a top bar 20. The shelf 6 is mounted between the side posts 17 at an arbitrary height, which is adjustable as will be further described below.

The movement of the sledge is guided by guide tracks 28 comprised in the fixed portion 15 of the support 9. More particularly, the sledge 10 is provided with wheels at an underside of the sledge 10, which wheels are running in the guide tracks 28.

The support 9 further comprises a base plate 29. The bottom bar 19 is attached to the top surface of the base plate 29, and a rotation device (not shown) is attached to a bottom surface of the base plate 29 and to a top surface of the sledge 10. The rotation device can be of any suitable common type known to the person skilled in the art, such as a ball bearing structure, etc.

Referring to Fig. 2, where the shelf 6 is shown from above and transparent, or with cut out portions, to uncover the support 9 underneath, the support 9 further comprises an arm 11 having a first end 12 pivotally connected with the shelving section 5 at a bottom end thereof, at a distance from a central axis of rotation 13 of the shelving section 5, and a second end 14 pivotally connected with a fixed portion 15 of the support 9. When the shelving section 5 is rotated from the display position to the refill position, due to the arm 11, which is pivoting during the rotation, the sledge 10 is first moved forwards a distance from a starting position, illustrated in Fig. 2, and then rearwards back to its starting position. The distance corresponds to the distance between the central rotation axis 13 and the pivot connection at the second end of the arm 11. More particularly, when a person grabs the shelving section 5 at a position displaced from the centre, and preferably close to one side or the other, and starts pulling it, the shelving section 5 will start to rotate while the sledge 10 starts moving forwards. The rotation is shown in steps in Figs. 2-6, and it is assumed that the person pulls the shelving section 5 to the left of the central rotation axis 13 in Fig. 2. Since the arm 11 is rigid, when the shelving section 5 is pulled forwards the bottom bar 13 pivots about the first end 12 of the arm 11, and thereby the sledge 10 starts moving forwards, since its lateral position is fixed. Simultaneously the arm 11 starts pivoting about its second end 14 towards the centre of the shelving section 5, i.e. to the left in Fig. 2.

As shown in Figs. 3-6, which are views from above the whole shelf assembly 1, in this embodiment the shelf assembly 1 comprises a structure at its top which structure resembles the support 9 at the bottom of the shelving section 5. More particularly, the top of the shelving section 5 is rotationally connected with a top holder 22, which top holder 22 struts the shelving section 5. The top holder 22 is not necessary if the support is made strong enough, but advantageous to enable a slimmer support 9. The top holder 22 comprises a telescoping beam 23 rotationally connected with the shelving section 5 at a top thereof and telescoping forward and rearward. The telescoping beam 23 is moving in a housing 24, which is a fixed part of the shelf assembly 1. Like the support 9 the top holder comprises an arm 25, which is vertically aligned with the arm 11 of the support 9. Therefore, the arm 11 of the support 9 is not visible in Figs. 3-6, because it is blocked by the arm 25 of the top holder 22. The arm 25 of the top holder 22 is pivotally connected, at a first end 26 thereof, with the top bar 20, at the same distance from the central rotation axis as the arm 11 of the support 9. At a second end 27 of the arm 25 it is pivotally connected with the housing 24 at a rear end of the housing 24. When the operation of rotating the shelving section 5 is continued, it is moved further forwards, as shown in Figs. 3 and 4, and thereby the shelf 6 avoids hitting the rear wall 2. The sledge 10 reaches its forward most position when the shelving section 5 has been rotated 90 degrees, shown in Fig. 5. In this position the arm 25 of the top holder 22 extends along the housing 24, and is hidden below it in the figure. During the continued rotation, shown in Fig 6, the sledge 10, and thus the shelving section 5, moves back rearwards to its starting position in the forward-rearward direction. Now the shelving section 5 has been rotated to its refill position, and in depth of the space it has the same position as in the display position. Consequently, the shelf 6 does not protrude out of the space as in the above-mentioned prior art shelf assembly. The arms 11, 25 have pivoted to a position where their first ends are positioned to the left of the central rotation axis 13 at the same distance as they were position to the right of the central rotation axis 13 in the display position.

Referring now to Figs. 7 and 8, the shelf 6 is provided with a respective clamping portion 30 at opposite ends of the shelf 6, wherein the clamping portions 30 fix the shelf 6 at the side posts 17, 18. Each clamping portion 30 comprises a hook portion 31 engaged with a respective side post 17, 18 at a first surface 32 of the side post 17, and a tightening portion 33 engaged with an opposite second surface 34 of the side post 17, whereby the side post 17 is clamped between the hook portion 31 and the tightening portion 33, and wherein the tightening portion 33 is untightenable for arbitrary height movement of the

shelf 6. More particularly, the shelf 6 comprises an end plate 35 at each end thereof, wherein the clamping portion 30 is attached to the end plate 35, wherein the hook portion 31 and the tightening portion 33 are attached to the end plate 35 with a mutual spacing, and wherein the hook portion 31 comprises a first edge surface 36 protruding from the end plate 35 and being engaged with the first surface 32 of the side post, and a second edge surface 37 extending perpendicular to the first edge surface 36 and being engaged with a third surface 38 of the side post 17 extending perpendicular to and adjacent to the first surface 32.

The tightening portion 33 comprises a nut 39 attached to the side plate 35, and a screw 40 arranged at the nut 39, protruding from the nut 39 towards the hook portion 31, and being engaged with the second surface 34 of the side post 17, wherein the screw 40 is arranged to be loosened to untighten the tightening portion 33.

While the invention has been illustrated and described in detail in the drawings and foregoing description, such illustration and description are to be considered illustrative or exemplary and not restrictive. The invention is not limited to the disclosed embodiment.

Other variations to the disclosed embodiment can be understood and effected by those skilled in the art in practicing the claimed invention, from a study of the drawings, the disclosure, and the appended claims. In the claims, the word "comprising" does not exclude other elements or steps, and the indefinite article "a" or "an" does not exclude a plurality. The mere fact that certain measures are recited in mutually different dependent claims does not indicate that a combination of these measures cannot be used to advantage. Any reference signs in the claims should not be construed as limiting the scope.

Modifications and variations such as would be apparent to the skilled addressee are considered to fall within the scope of the present invention. The present invention is not to be limited in scope by any of the specific embodiments described herein. These embodiments are intended for the purpose of exemplification only. Functionally equivalent products, formulations and methods are clearly within the scope of the invention as described herein. It will be understood by those skilled in the art that various changes in form and details may be made therein without departing from the spirit and scope of the invention as defined by the appended claims.

Example embodiments are provided so that this disclosure will be thorough, and will fully convey the scope to those who are skilled in the art. Numerous specific details are set forth such as examples of specific components, devices, and methods, to provide a thorough understanding of embodiments of the present disclosure. It will be apparent to those skilled in the art that specific details need not be employed, that example embodiments may be embodied in many different forms and that neither should be construed to limit the scope of the disclosure. In some example embodiments, well-known processes, well-known device structures, and well-known technologies are not described in detail.

Such variations are not to be regarded as a departure from the disclosure, and all such modifications are intended to be included within the scope of the disclosure.

The method steps, processes, and operations described herein are not to be construed as necessarily requiring their performance in the particular order discussed or illustrated, unless specifically identified as an order of performance. It is also to be understood that additional or alternative steps may be employed.

Reference to positional descriptions and spatially relative terms), such as “inner”, “outer”, “beneath”, “below”, “lower”, “above”, “upper” and the like, are to be taken in context of the embodiments depicted in the figures, and are not to be taken as limiting the invention to the literal interpretation of the term but rather as would be understood by the skilled addressee.

Although the terms first, second, third, etc. may be used herein to describe various elements, components, regions, layers and/or sections, these elements, components, regions, layers and/or sections should not be limited by these terms. These terms may be only used to distinguish one element, component, region, layer or section from another region, layer or section. Terms such as “first”, “second”, and other numerical terms when used herein do not imply a sequence or order unless clearly indicated by the context. Thus, a first element, component, region, layer or section discussed below could be termed a second element, component, region, layer or section without departing from the teachings of the example embodiments.

It will be understood that when an element is referred to as being “on”, “engaged”, “connected” or “coupled” to another element/layer, it may be directly on, engaged, connected or coupled to the other element/layer or intervening elements/layers may be present. Other words used to describe the relationship between elements/layers should be interpreted in a like fashion (e.g., “between”, “adjacent”). As used herein the term “and/or” includes any and all combinations of one or more of the associated listed items.

2017443355 29 Feb 2024

5

The terminology used herein is for the purpose of describing particular example embodiments only and is not intended to be limiting. As used herein, the singular forms “a”, “an” and “the” may be intended to include the plural forms as well, unless the context clearly indicates otherwise. The terms “comprise”, “comprises”, “comprising”, “including”, and “having”, or variations thereof are inclusive and therefore specify the presence of stated features, integers, steps, operations, elements, and/or components, but do not preclude the presence or addition of one or more other features, integers, steps, operations, elements, components, and/or groups thereof.

CLAIMS:

2017443355 29 Feb 2024

5 1. A shelf assembly for displaying products, the shelf assembly configured to be placed in a space limited in depth by a rear boundary surface and laterally by lateral boundary surfaces, the shelf assembly having a shelving section with a front and a rear, which shelving section comprises a shelf, the shelving section being rotatable about an axis of rotation between a display position, in which the shelf is accessible from the front of the shelving section, and a refill position, in which the shelf is accessible from the rear of the shelving section, wherein the shelf assembly further comprises a support, which comprises a sledge rotatably supporting the shelving section, and being movable in depth of the space, in a forward-rearward direction, and an arm having a first end pivotally connected with the shelving section at a bottom end thereof, at a distance from the axis of rotation, and having a second end pivotally connected with a fixed portion of the support, such that when the shelving section is rotated from the display position to the refill position, due to the arm, which is pivoting during the rotation, the sledge is first moved

10

15 forwards a distance from a starting position, and then rearwards back to its starting position, and wherein the shelving section further comprises a frame having opposite first and second side posts, wherein the shelf is mounted between the side posts at an arbitrary height, wherein the shelf is provided with a respective clamping portion at opposite ends of the shelf, wherein the clamping portions fix the shelf at the side posts,

20 wherein each clamping portion comprises a hook portion engaged with a respective side post at a first surface thereof, and a tightening portion engaged with an opposite second surface of the side post, whereby the side post is clamped between the hook portion and the tightening portion, and wherein the tightening portion is untightenable for arbitrary height movement of the shelf.

25 2. The shelf assembly according to Claim 1, wherein the shelf comprises an end plate at each end thereof, wherein the clamping portion is attached to the end plate, wherein the hook portion and the tightening portion are attached to the end plate with a mutual spacing, and wherein the hook portion comprises a first edge surface protruding from the end plate and being engaged with the first surface of the side post, and a second

30 edge surface extending perpendicular to the first edge surface and being engaged with a third surface of the side post extending perpendicular to and adjacent to the first surface.

3. The shelf assembly according to Claim 2, wherein the tightening portion comprises a nut attached to the side plate, and a screw arranged at the nut, protruding

from the nut towards the hook portion and being engaged with the opposite second surface of the side post, wherein the screw is arranged to be loosened to untighten the tightening portion.

4. The shelf assembly according to any one of the preceding claims, wherein the sledge is provided with wheels at an underside of the sledge, which wheels are running in guide tracks.

5. The shelf assembly according to any one of the preceding claims, comprising a top holder, wherein the top of the shelving section is rotationally connected with a top holder, which top holder struts the shelving section.

6. The shelf assembly according to claim 5, wherein the top holder comprises a telescoping beam rotationally connected with the shelving section at a top thereof and telescoping forward and rearward, and wherein the telescoping beam is moving in a housing, which is a fixed part of the shelf assembly.

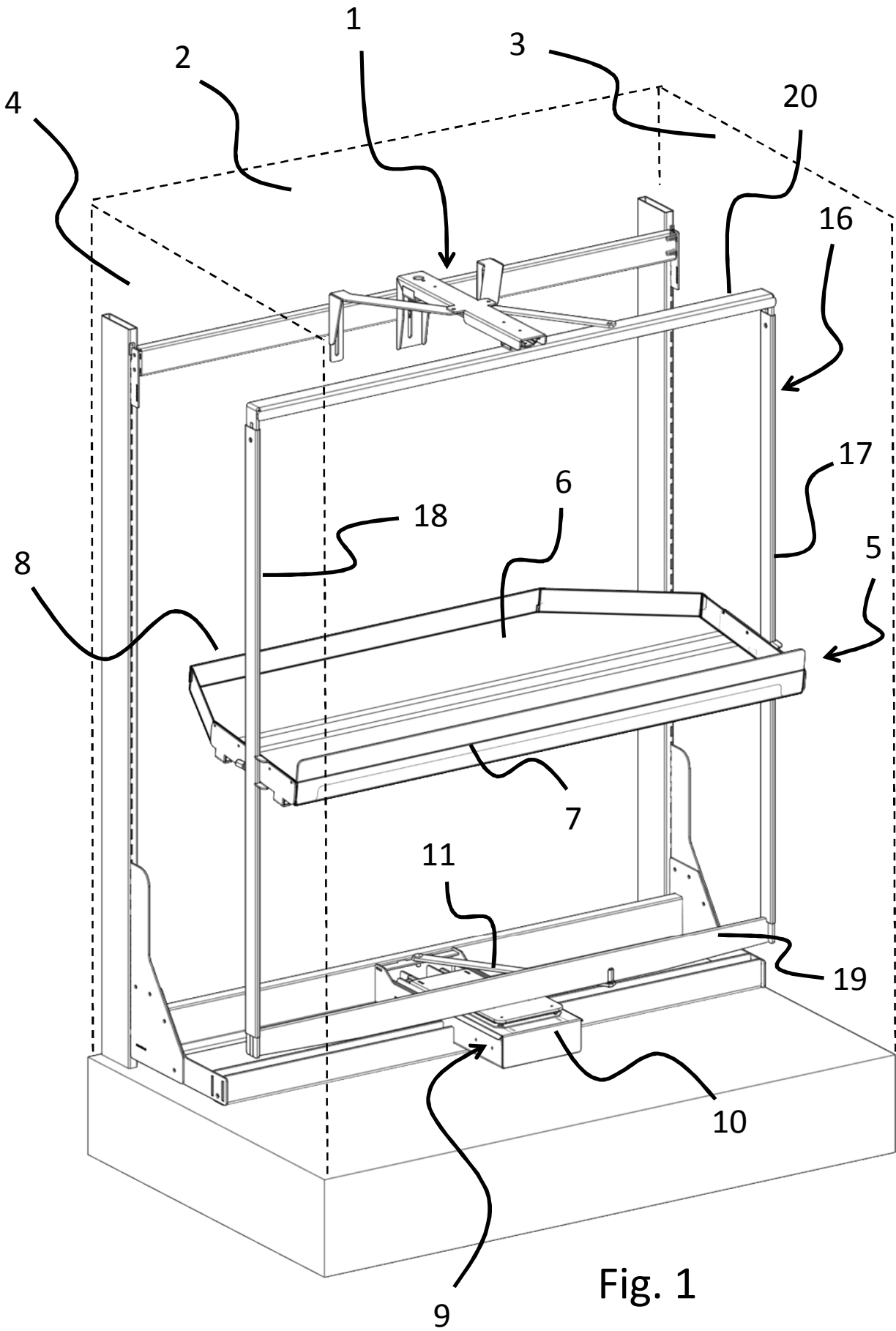
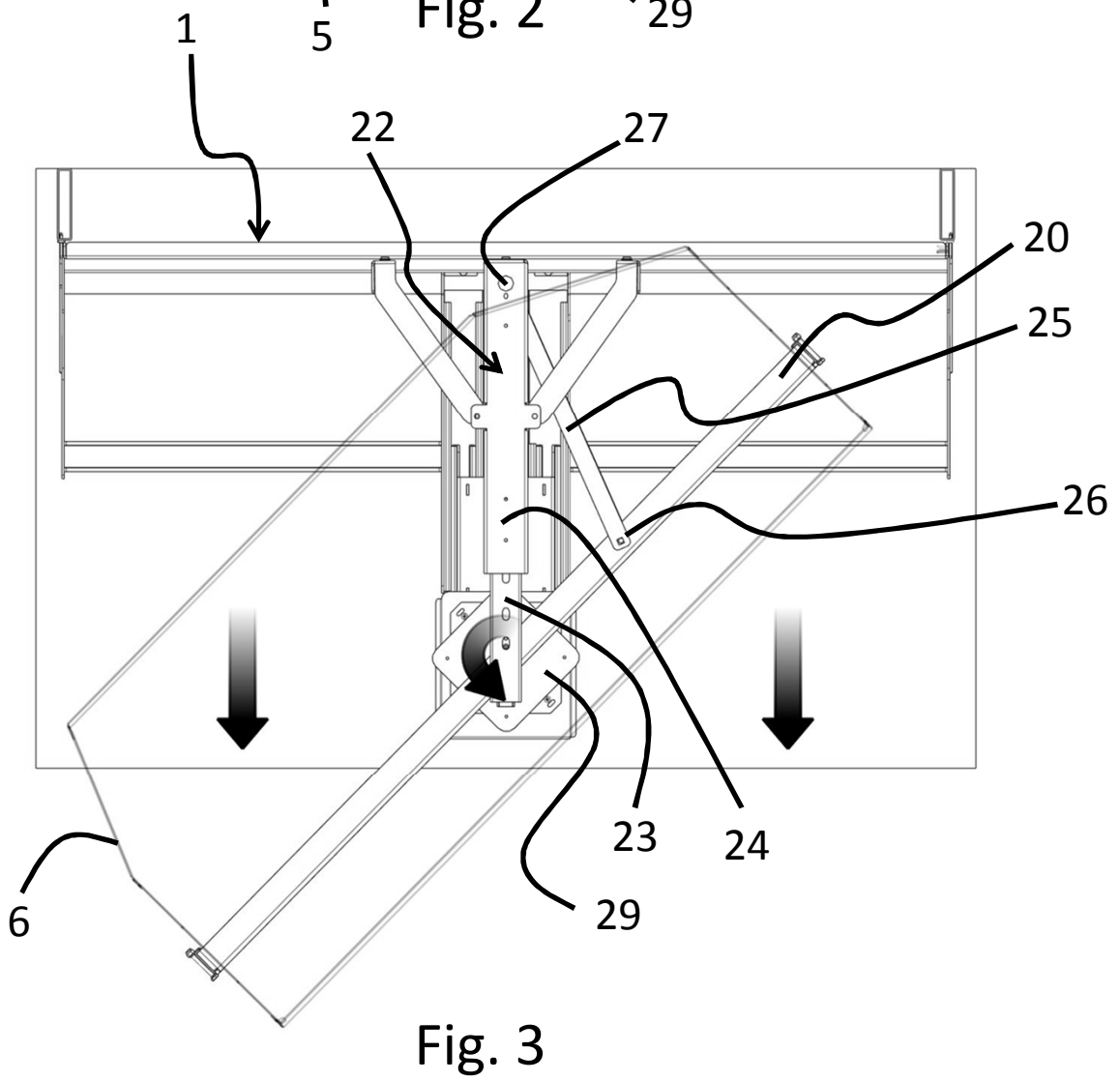
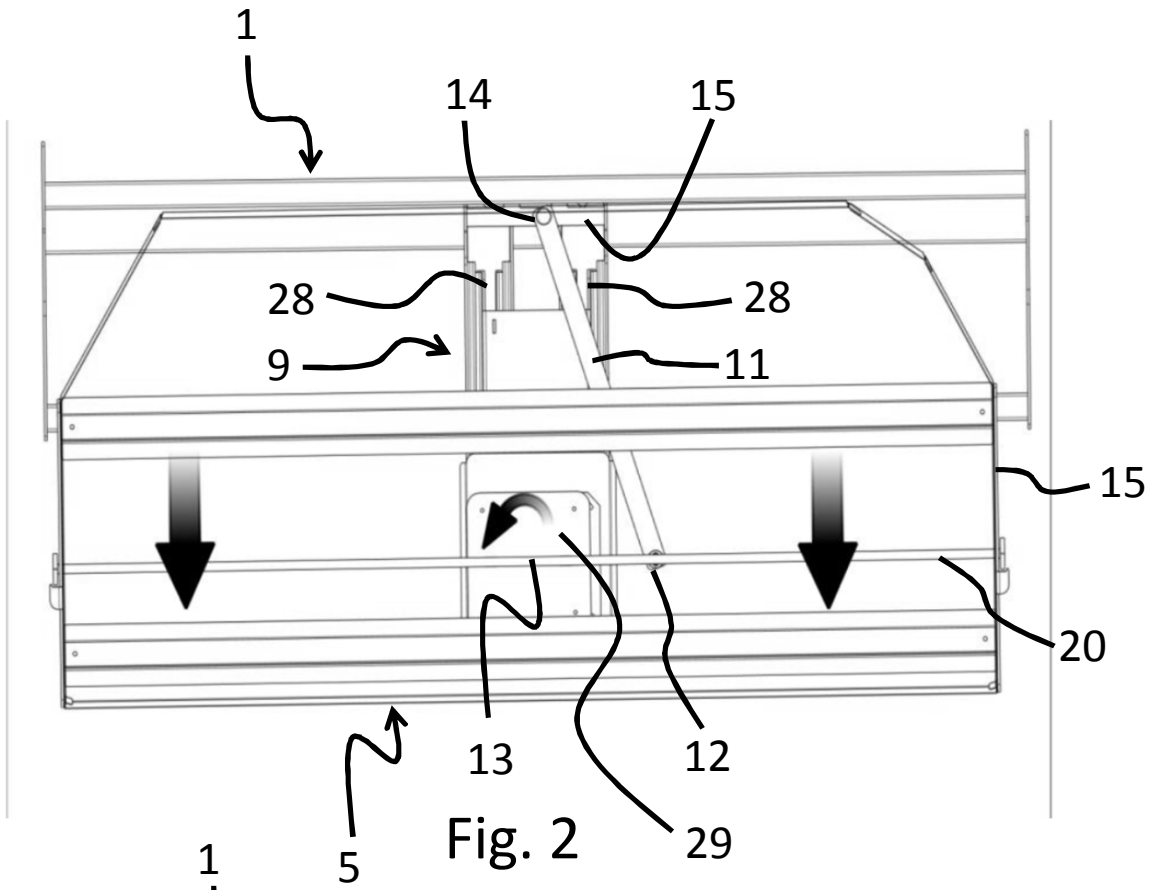

Fig. 1



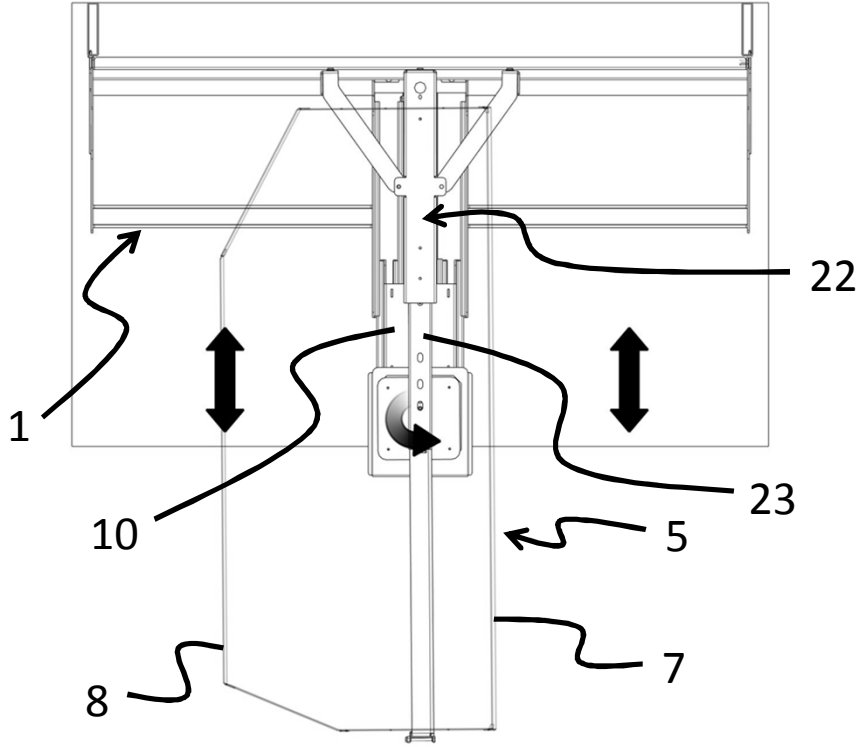

Fig. 4

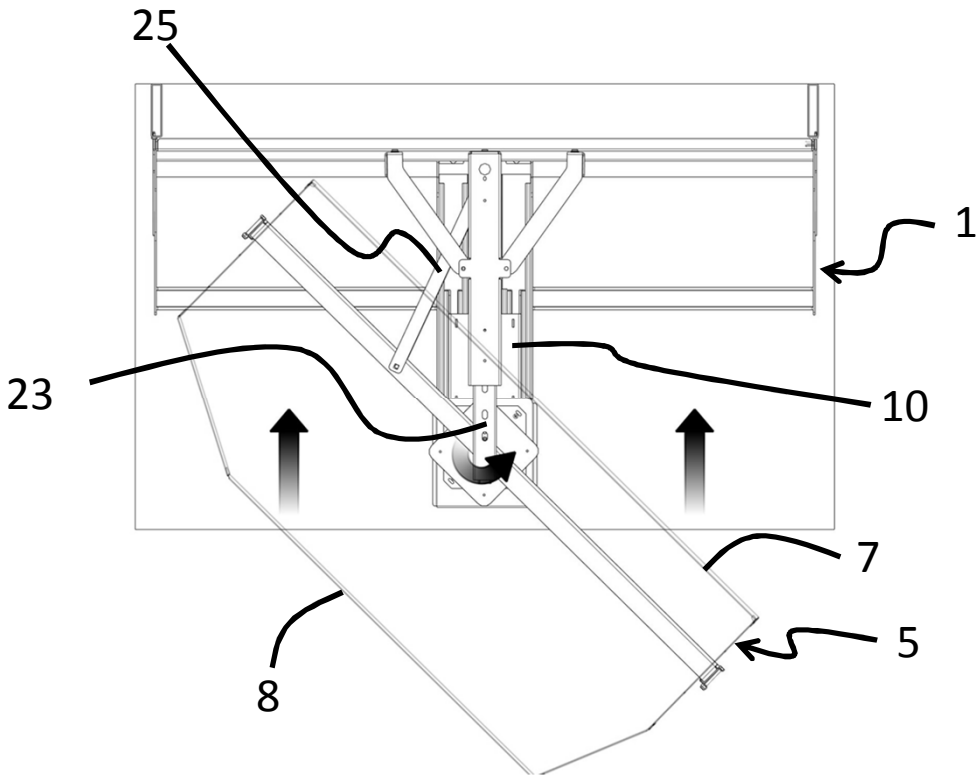

Fig. 5

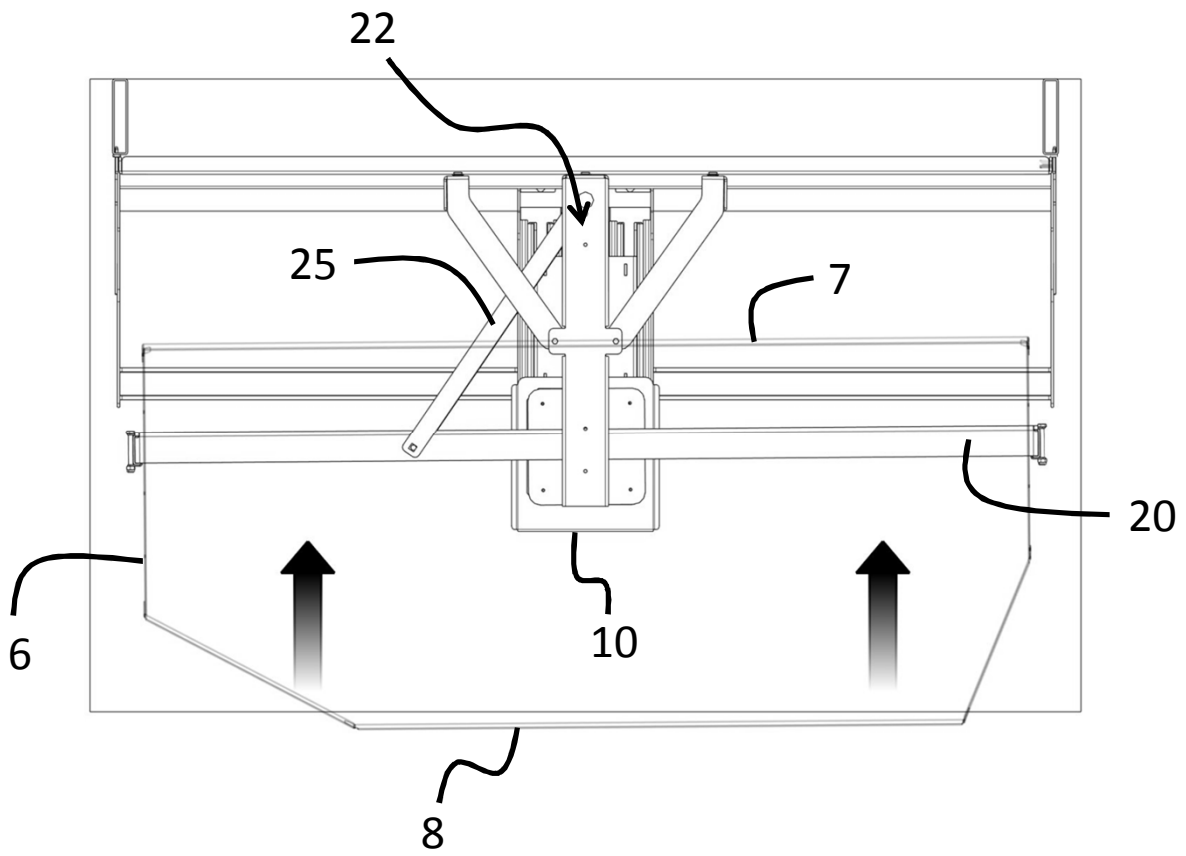

Fig. 6

