



(11) **EP 1 422 360 B1**

(12) **EUROPEAN PATENT SPECIFICATION**

(45) Date of publication and mention of the grant of the patent:  
**11.03.2009 Bulletin 2009/11**

(51) Int Cl.:  
**E04H 15/48<sup>(2006.01)</sup> E04H 15/36<sup>(2006.01)</sup>**

(21) Application number: **03257288.5**

(22) Date of filing: **19.11.2003**

(54) **A joint**

Verbindung

Joint

(84) Designated Contracting States:  
**BE DE FR GB IT NL**

(30) Priority: **19.11.2002 GB 0227001**

(43) Date of publication of application:  
**26.05.2004 Bulletin 2004/22**

(73) Proprietor: **Fox International Group Limited**  
**Hainault,**  
**Essex IG6 3UT (GB)**

(72) Inventors:  
• **Fox, Clifford Royston**  
**Danbury, Essex CM3 4PG (GB)**

• **Cottis, Maxwell Stewart**  
**Braintree, Essex CM7 9FD (GB)**

(74) Representative: **Crouch, David John et al**  
**Bromhead Johnson**  
**19 Buckingham Street**  
**London**  
**WC2N 6EF (GB)**

(56) References cited:  
**EP-A- 0 684 355 EP-A- 0 704 586**  
**US-A- 4 750 509**

**EP 1 422 360 B1**

Note: Within nine months of the publication of the mention of the grant of the European patent in the European Patent Bulletin, any person may give notice to the European Patent Office of opposition to that patent, in accordance with the Implementing Regulations. Notice of opposition shall not be deemed to have been filed until the opposition fee has been paid. (Art. 99(1) European Patent Convention).

## Description

**[0001]** The present invention relates to a breakable joint as specified in the preamble of Claim 1, namely a joint comprising two parts which are pivotably connected to one another so that they can be moved relative to one another about the pivot from a folded position to an open position, in which an end portion of one of the parts is received in a mouth portion of the other of the parts, and a slidable locking member arranged on or constituted by the said mouth portion or the said end portion, the locking member being slidable in a direction which is transverse of the pivot axis from a retracted position, in which it permits the said end portion to be received by the mouth portion, to a forward position, in which, with the said end portion located in the mouth portion, it inhibits subsequent movement of the two parts about the pivot into the folded position until the locking member is retracted, the locking member being urged by resilient means into its forward position so that as the said two parts are moved about the pivot from the folded position to the open position, the locking member initially abuts the mouth portion or the end portion so that it is moved relative to that portion towards its retracted position until the said two parts reach their open position, whereupon the locking member snaps into its forward position under the action of the resilient means. Such a breakable joint is known eg from any of EP-A-0 684 355 or EP-A-0 704 586 or US-A-4 750 509.

**[0002]** Preferably, the locking member is arranged on the said end portion.

**[0003]** Such a joint is disclosed in co-pending European Patent Application EP-A-1 310 616 in the name of Fox Design International Limited. In that context, the joint is used to join sections of a tent frame together, although it will be appreciated that the joint may be used in other applications where two elongate sections are folded together for storage, and opened outwardly for use, for example in various kinds of stands and supports.

**[0004]** One problem encountered with such a joint especially but not exclusively when it is used in the frame of a tent is that during dismantling after the joint has been broken, it may accidentally be locked in the open position before the dismantling procedure has been completed.

**[0005]** An aim of the present invention is to obviate this disadvantage.

**[0006]** Accordingly, the present invention provides a joint having the features set out in the opening paragraph of the present specification in which a selectively operable catch is provided on the joint to enable the locking member to be held in its retracted position, against the force of the resilient means, when it is desired to avoid accidental locking of the said two parts in their open position.

**[0007]** The catch may be so constructed that it is slidable between a locking position and a non-locking position.

**[0008]** This can be effected most readily if the catch is

slidable in a direction which is generally parallel to the pivot axis.

**[0009]** The catch may be provided with a thumb-engageable portion on the outside of the locking member, and an abutment portion on the inside of the locking member, there being a further abutment portion on the said end portion which engages the abutment portion of the catch when the latter is in its locking position and the locking member is in its retracted position.

**[0010]** A slanting portion may be provided on the catch and/or on the said end portion to urge the catch into its non-locking position when the locking member is moved from its forward position to its retracted position.

**[0011]** The present invention extends to a tent or canopy having a frame which is collapsible and erectable by means of at least one joint made in accordance with the present invention.

**[0012]** An example of a joint and of a tent or canopy made in accordance with the present invention will now be described with reference to the accompanying drawings, in which:

Figure 1 shows a side view of a joint embodying the present invention;

Figure 2 shows a part axial sectional view of the device shown in Figure 1;

Figure 3 shows a cross-sectional view of the device shown in Figure 1 taken in the plane indicated by the line III-III shown therein;

Figure 4 shows a cross-sectional view of the joint shown in Figure 1 taken in the plane indicated by the line IV-IV thereof;

Figure 5 shows a view from above of a portion of the joint shown in Figure 1;

Figure 6 shows a view from above of another portion of the joint shown in Figure 1;

Figure 7 shows an underneath view of a portion of the joint shown in Figure 1;

Figure 8 shows a canopy frame incorporating a plurality of joints each as shown in Figures 1 to 7, and

Figure 9 shows the frame of Figure 8 in a collapsed condition.

**[0013]** A breakable pivot joint 10 shown in Figures 1 to 7 comprises two generally tubular joint parts 12 and 14 to which are connected, when in use, two respective ends 13 and 15 of tent-frame rib or bar sections. These sections may be tubular and made of aluminium, and are connected and secured to their associated joint parts 12 and 14 by a combination of a tight fit of respective ends of the rib or bar sections within the tubular parts and by screws through screw holes 16 and 18 and corresponding holes in the ends 13 and 15. The location of such holes in the rib or bar sections, and other holes (not shown) at their other ends can be used to ensure that further joints at those other ends are correctly oriented in relation to the illustrated joint to facilitate folding-up of

the assembly. Thus, the parts 12 and 14 have respective tubular portions 12a and 14a. These have respective axes at about 140° to one another when they are in their relative open position as shown in Figure 1. The joint parts 10 and 12 are each also provided with a hook-like clip 20 from which may be suspended sheeting material of a tent.

**[0014]** The two joint parts 12 and 14 are pivotably connected together by means of a pivot 22 which has a transverse turning axis offset from the axes of the tubular portions 12a and 14a.

**[0015]** The joint part 12 has a female retaining portion or mouth portion 24 which opens towards the joint part 14 as shown in Figure 2. The joint part 14 has a corresponding end portion 26 or male retaining portion which is received in the mouth portion 24 of the joint part 12. A locking member in the form of a slider 28 has a thumb-pad 30, extending around the outside of the end portion 26 of the joint part 14, and an inner serrated portion 32 which is immediately adjacent to the said end portion or male retaining portion 26. Corresponding serrations on the said end portion or male portion 26 engage the serrations of the slider 28. The flexure of the rib or bar sections held by the joint 10 when the latter is in use, as a result of the inward pull of tent material, tends to break the pivot joint 10 to pivot the said end portion 26 out of engagement with the mouth or female retaining portion 24. However, the abutment of the inner portion 32 against the roof of the mouth portion 24 prevents this from happening, unless and until the user operates the slider 28 to disengage the portions 24 and 26.

**[0016]** To enable such disengagement to happen, the said end portion or male portion 26 is so dimensioned and positioned in relation to the pivot 22 and the mouth portion 24 that a gap 34 is present between the mouth portion 24 and the said end portion 26 on the pivot side of the joint 10. Furthermore, a lower portion 36 which extends from and is integrally moulded with the slider 28 is urged towards the part 12 by a helical compression spring 38 provided in a spring cavity 40 of the joint part 14. As a result, parts 12 and 14 may be opened further until the gap 34 is closed and the mouth portion 24 no longer abuts the slider 28. The slider 28 may now be pulled outwardly from the mouth portion 24 against the restoring force of the compression spring 38. This enables the whole joint 10 now to be folded by pivoting the joint parts 12 and 14 relative to one another about the pivot 22 until the end portion 26 is entirely clear of the mouth portion 24.

**[0017]** A catch 42 is provided on the slider 28. The catch 42 comprises a thumb-engageable part 44 on the outside of the slider 28 and an abutment portion 46 on the inside of the slider 28. The parts 44 and 46 of the catch 42 are connected together by a neck portion 48. The neck portion 48 extends through a slot 50 provided in the slider 28. This slot has a widened end portion 52 to facilitate insertion of the abutment portion 46 through the slot 50. This slot is shown most clearly in Figure 6.

**[0018]** That part of the end portion 26 which is underneath the slider 28 is shown most clearly in Figure 5. It is formed with a recess 54 engaged by the abutment portion 46 of the catch 42 when the latter is in its locking position and the slider 28 is in its retracted position. It can be seen in this position that an abutment surface 56 on one side of the recess 54 abuts the abutment portion 46 of the catch 42.

**[0019]** The end portion 26 is provided with a slanting surface 58 which meets the abutment surface 56. The abutment portion 46 of the catch 42 is also provided with slanting surface 60. In the event that the catch 42 is in its locking position with the slider 28 in its forward position, retraction of the slider 28 causes the slanting surfaces 58 and 60 to abut one another and, with further retraction of the slider 28 to cause the catch 42 to slide into its unlocking position as the neck 48 thereof moves within the slot 50. Movement of the catch 42 in the other direction will now bring the abutment portion 46 thereof into position within the recess 54 to hold the slider 28 in its retracted position until the user engages the thumb-engageable part 44 of the catch 22 with his or her thumb to move the catch back to its unlocking position.

**[0020]** A canopy shown in Figures 8 and 9 comprises a frame 80 comprising a plurality of joints 10, each of which has the construction illustrated and described with reference to Figures 1 to 7. These joints 10 interconnect a series of rod sections 82 to form a series of arches spanning two spaced-apart support hubs 84 and 86. The canopy cover is attached by loops (not shown) to the hooks 20 of the joints 10.

**[0021]** When the canopy is collapsed, the joints are unlocked in the manner described herein so that the canopy frame can be folded-up substantially as shown in Figure 9. To ensure that none of the joints are accidentally opened and locked in their open position while the canopy is being collapsed, the catch 42 of each joint 10 is shifted to its locking position while the slider 28 is in its retracted position. This retains the slider 28 in its retracted position. The catch 42 is shifted back into its unlocking position when it is desired to re-erect the canopy.

**[0022]** Numerous variations and modifications to the illustrated joint and canopy can be made if without taking the resulting constructions outside the scope of the present invention as claimed below. For example, the locking slider 28 may be arranged on the mouth portion 24, on the inside thereof, instead of on the said end portion 26. The tubular portions 12a and 14a of the parts 12 and 14 may have respective axes which are at a different angle to the one illustrated, or indeed they may be co-linear.

**[0023]** What has been shown as a canopy in Figures 8 and 9 can be constructed rather as a tent with a single central hub raised above the ground by a series of legs, each of which includes a breakable joint as shown in Figures 1 to 7.

**[0024]** It will be appreciated that in the event that a joint 10 breaks, it can be readily replaced by unscrewing the

screws at the screw-holes 16 and 18, pulling out the rod or bar sections from the joint, inserting those sections in a replacement joint, and using the screws to secure those sections in place.

### Claims

1. A breakable joint (10) comprising two parts (12 and 14) which are pivotably connected to one another so that they can be moved relative to one another about the pivot (22) from a folded position to an open position, in which an end portion (26) of one of the parts (14) is received in a mouth portion (24) of the other of the parts (12), and a slidable locking member (28) arranged on or constituted by the said mouth portion (24) or the said end portion (26), the locking member (28) being slidable in a direction which is transverse of the pivot axis from a retracted position, in which it permits the said end portion (26) to be received by the mouth portion (24), to a forward position, in which, with the said end portion (26) located in the mouth portion (24), it inhibits subsequent movement of the two parts (12 and 14) about the pivot (22) into the folded position until the locking member (28) is retracted, the locking member (28) being urged by resilient means (38) into its forward position so that as the said two parts (12 and 14) are moved about the pivot (22) from the folded position to the open position, the locking member (28) initially abuts the mouth portion (24) or the end portion (26) so that it is moved relative to that portion towards its retracted position until the said two parts (12 and 14) reach their open position, whereupon the locking member (28) snaps into its forward position under the action of the resilient means (38), **characterised in that** a selectively operable catch (42) is provided on the joint (10) to enable the locking member (28) to be held in its retracted position, against the force of the resilient means (38), when it is desired to avoid accidental locking of the said two parts (12 and 14) in their open position.
2. A breakable joint according to claim 1, **characterised in that** the locking member (28) is arranged on the said end portion (26).
3. A breakable joint according to claim 1 or claim 2, **characterised in that** the catch (42) is so constructed that it is slidable between a locking position and a non-locking position.
4. A breakable joint according to claim 3, **characterised in that** the catch (42) is slidable in a direction which is generally parallel to the pivot axis.
5. A breakable joint according to any preceding claim, **characterised in that** the catch (42) is provided with

a thumb-engageable portion (44) on the outside of the locking member (28), and an abutment portion (46) on the inside of the locking member (28), there being a further abutment portion (56) on the said end portion (26) which engages the abutment portion (46) of the catch (42) when the latter is in its locking position and the locking member (28) is in its retracted position.

6. A breakable joint according to any preceding claim, **characterised in that** a slanting portion is provided on the catch (42) and/or on the said end portion (26) to urge the catch (42) into its non-locking position when the locking member (28) is moved from its forward position to its retracted position.
7. A tent or canopy having a frame (80) which is collapsible and erectable by means of at least one joint (10) as claimed in any preceding claim.

### Patentansprüche

1. Zerbrechliches Gelenk (10), das zwei Teile (12 und 14), die schwenkbar miteinander verbunden sind, so dass sie relativ zueinander um die Drehachse (22) aus einer zusammengeklappten Position in eine geöffnete Position bewegt werden können, wobei in der geöffneten Position ein Endabschnitt (26) eines der Teile (14) in einem Mündungsabschnitt (24) des Anderen der Teile (12) aufgenommen ist, und ein gleitfähiges Verriegelungselement (28), das an dem Mündungsabschnitt (24) oder an dem Endabschnitt (26) angeordnet oder durch diesen gebildet ist, umfasst, wobei das Verriegelungselement (28) in einer Richtung, die quer zu der Schwenkachse verläuft, aus einer zurückgezogenen Position, in der es zulässt, dass der Endabschnitt (26) in dem Mündungsabschnitt (24) aufgenommen ist, in eine vordere Position, in der es bei in dem Mündungsabschnitt (24) befindlichem Endabschnitt (26) eine anschließend Bewegung der zwei Teile (12 und 14) um die Drehachse (22) in die zusammengeklappte Position verhindert, bis das Verriegelungselement (28) zurückgezogen wird, gleiten kann, wobei das Verriegelungselement (28) durch elastische Mittel (38) in seine vordere Position gedrängt wird, so dass das Verriegelungselement (28) dann, wenn die zwei Teile (12 und 14) um die Drehachse (22) aus der zusammengeklappten Position in die geöffnete Position bewegt werden, zunächst an dem Mündungsabschnitt (24) oder an dem Endabschnitt (26) anliegt, so dass es relativ zu jenem Abschnitt in seine zurückgezogene Position bewegt wird, bis die zwei Teile (12 und 14) ihre geöffnete Position erreichen, woraufhin das Verriegelungselement (28) unter der Wirkung der elastischen Mittel (38) in seine vordere Position einschnappt, **dadurch gekennzeichnet, dass** eine

wahlweise betätigbare Sperrklinke (42) an dem Gelenk (10) vorgesehen ist, um zu ermöglichen, dass das Verriegelungselement (28) entgegen der Kraft der elastischen Mittel (38) in seiner zurückgezogenen Position gehalten wird, wenn gewünscht ist, eine zufällige Verriegelung der zwei Teile (12 und 14) in ihre geöffnete Position zu vermeiden.

2. Zerbrechliches Gelenk nach Anspruch 1, **dadurch gekennzeichnet, dass** das Verriegelungselement (28) an dem Endabschnitt (26) angeordnet ist. 10
3. Zerbrechliches Gelenk nach Anspruch 1 oder Anspruch 2, **dadurch gekennzeichnet, dass** die Sperrklinke (42) so konstruiert ist, dass sie zwischen einer verriegelten Position und einer nicht verriegelten Position gleiten kann. 15
4. Zerbrechliches Gelenk nach Anspruch 3, **dadurch gekennzeichnet, dass** die Sperrklinke (42) in einer Richtung gleiten kann, die zu der Drehachse im Allgemeinen parallel ist. 20
5. Zerbrechliches Gelenk nach einem vorhergehenden Anspruch, **dadurch gekennzeichnet, dass** die Sperrklinke (42) mit einem Abschnitt an der Außenseite des Verriegelungselements (28), mit dem ein Daumen in Eingriff gelangen kann, und mit einem Anschlagabschnitt (46) an der Innenseite des Verriegelungselements (28) versehen ist, wobei an dem Endabschnitt (26) ein weiterer Anschlagabschnitt (56) vorhanden ist, der mit dem Anschlagabschnitt (46) der Sperrklinke (42) in Eingriff gelangt, wenn die Letztere in ihrer verriegelten Position ist und das Verriegelungselement (28) in seiner zurückgezogenen Position ist. 25  
30  
35
6. Zerbrechliches Gelenk nach einem vorhergehenden Anspruch, **dadurch gekennzeichnet, dass** an der Sperrklinke (42) und/oder an dem Endabschnitt (26) ein schräger Abschnitt vorgesehen ist, um die Sperrklinke (42) in ihre nicht verriegelte Position zu drängen, wenn das Verriegelungselement (28) aus seiner vorderen Position in seine zurückgezogene Position bewegt wird. 40  
45
7. Zelt oder Zeltvordach, das einen Rahmen (80) besitzt, der durch wenigstens ein Gelenk (10) nach einem vorhergehenden Anspruch zusammenklappbar und aufrichtbar ist. 50

## Revendications

1. Joint d'articulation (10) débloquable, comprenant deux parties (12 et 14) reliés à pivotement l'une à l'autre, de manière à pouvoir être déplacées, l'une par rapport à l'autre autour du pivot (22), d'une po-

sition pliée à une position ouverte, dans laquelle une partie d'extrémité (26) d'une (14) des parties est logée dans une partie d'embouchure (24) de l'autre (12) des parties, et un organe de verrouillage (28) coulissant, agence sur ou constitué par ladite partie d'embouchure (24) ou ladite partie d'extrémité (26), l'organe de verrouillage (28) étant susceptible de coulisser dans une direction transversale à l'axe de pivot, d'une position rétractée, dans laquelle il permet à ladite partie d'extrémité (26) d'être logée par la partie d'embouchure (24), à une position avancée, dans laquelle, ladite partie d'extrémité (26) étant située dans la partie d'embouchure (24), il empêche tout déplacement subséquent des deux parties (12 et 14) autour du pivot (22) dans la position pliée, jusqu'à ce que l'organe de verrouillage (28) soit rétracté, l'organe de verrouillage (28) étant sollicité par des moyens élastiques (38) pour passer à sa position avancée, de manière que, lorsque lesdites deux parties (12 et 14) sont déplacées autour du pivot (22) de la position pliée à la position ouverte, l'organe de verrouillage (28) vienne initialement en butée avec la partie d'embouchure (24) ou la partie d'extrémité (26), de manière qu'il soit déplacé par rapport à cette partie, vers sa position rétractée, jusqu'à ce que lesdites deux parties (12 et 14) atteignent leur position ouverte, à la suite de quoi l'organe de verrouillage (28) s'encliquète dans sa position avancée sous l'action des moyens élastiques (38), **caractérisé en ce qu'un cliquet (42)**, actionnable sélectivement, est prévu sur le joint d'articulation (10) pour permettre à l'organe de verrouillage (28) d'être maintenu en sa position rétractée, à l'encontre de la force des moyens élastiques (38), lorsqu'on souhaite éviter tout verrouillage accidentel desdites deux parties (12 et 14) à leur position ouverte.

2. Joint d'articulation débloquable selon la revendication 1, **caractérisé en ce que** l'organe de verrouillage (28) est agencé sur ladite partie d'extrémité (26).
3. Joint d'articulation débloquable selon la revendication 1 ou la revendication 2, **caractérisé en ce que** le cliquet (42) est construit de manière à pouvoir coulisser entre une position de verrouillage et une position de non-verrouillage.
4. Joint d'articulation débloquable selon la revendication 3, **caractérisé en ce que** le cliquet (42) est susceptible de coulisser dans une direction globalement parallèle à l'axe de pivot.
5. Joint d'articulation débloquable selon l'une quelconque des revendications précédentes, **caractérisé en ce que** le cliquet (42) est muni d'une partie (44) susceptible d'être mise en prise par un pouce, à l'extérieur de l'organe de verrouillage (28), et d'une partie de butée (46) à l'intérieur de l'organe de verrouilla-

ge (28), une autre partie de butée (56) étant prévue sur ladite partie d'extrémité (26) venant en prise avec la partie de butée (46) du cliquet (42) lorsque ce dernier se trouve à sa position de verrouillage et que l'organe de verrouillage (28) se trouve à sa position rétractée. 5

6. Joint d'articulation débloquable selon l'une quelconque des revendications précédentes, **caractérisé en ce qu'**une partie inclinée est prévue sur le cliquet (42) et/ou sur ladite partie d'extrémité (26), de manière à solliciter le cliquet (42) dans sa position de non-verrouillage, lorsque l'organe de verrouillage (28) est déplacé de sa position avancée à sa position rétractée. 10 15

7. Tente ou auvent comprenant une structure (80) susceptible d'être repliée et pouvant être érigée au moyen d'au moins un joint d'articulation (10) tel que revendiqué selon l'une quelconque des revendications précédentes. 20

25

30

35

40

45

50

55

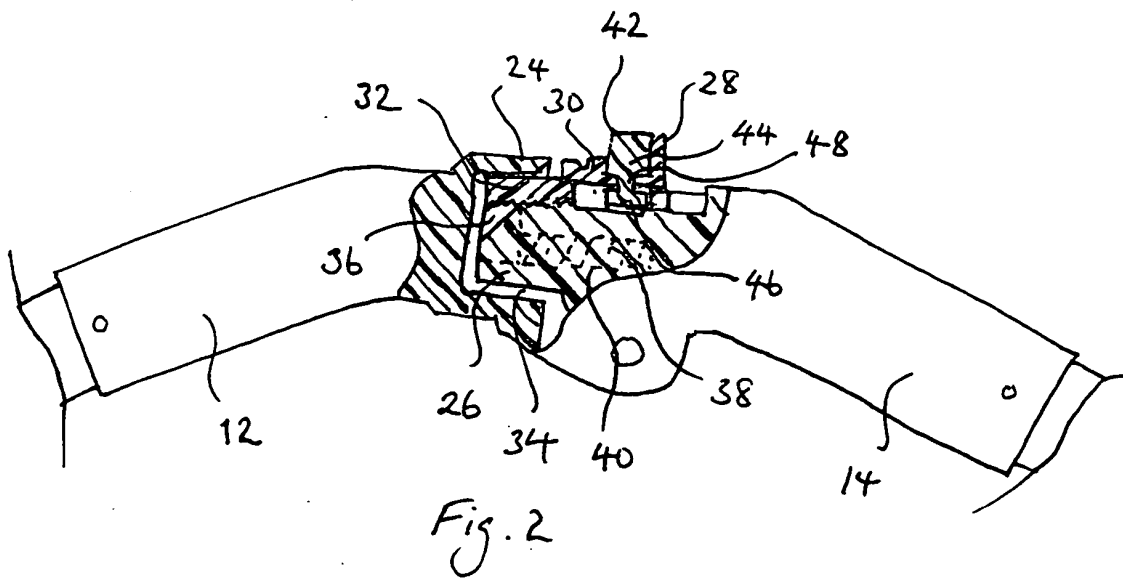
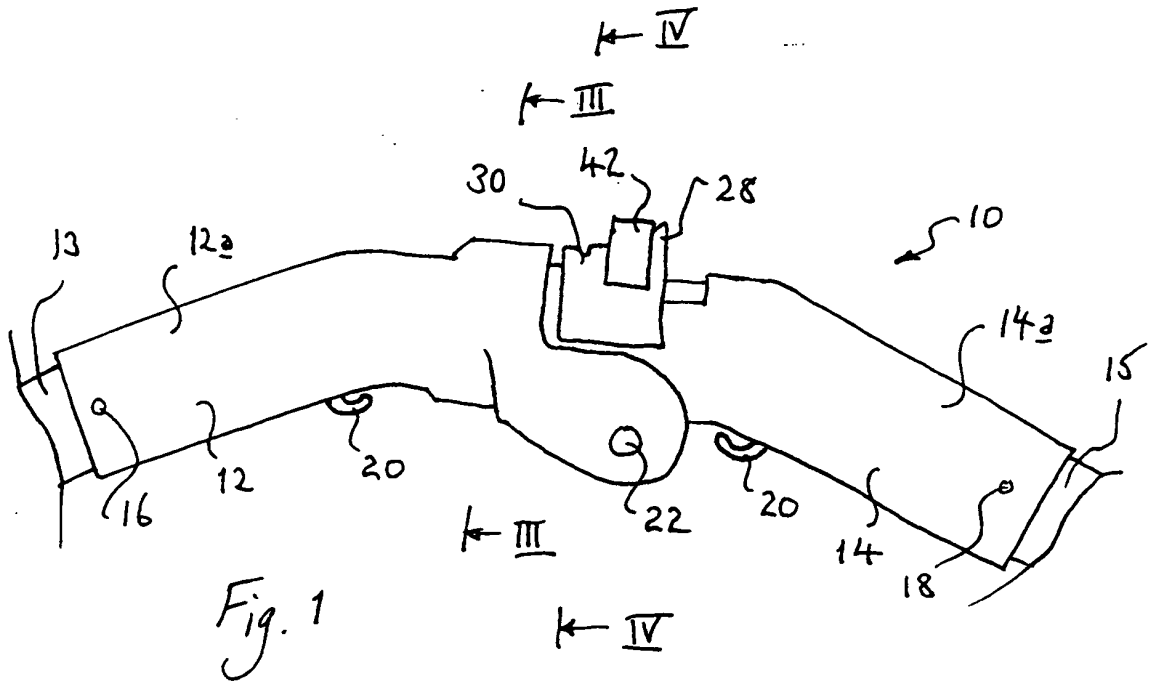

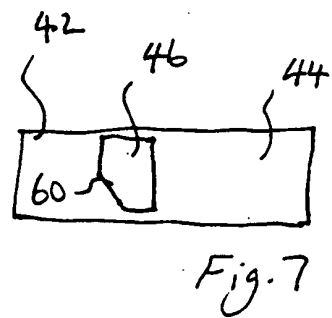
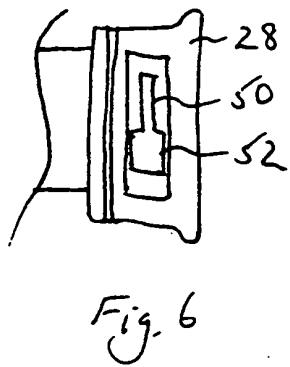
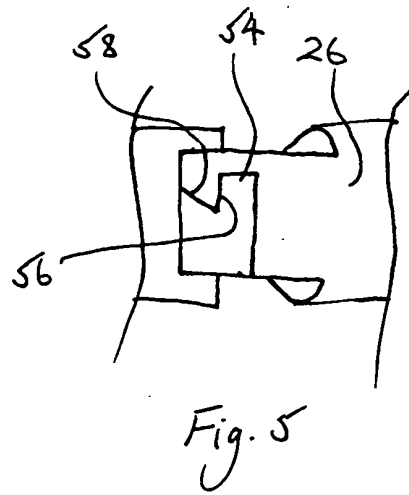
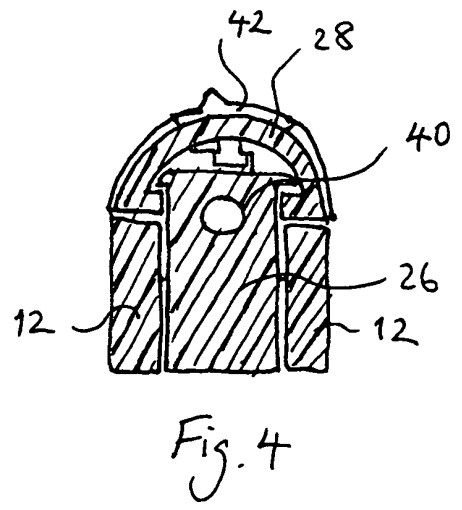
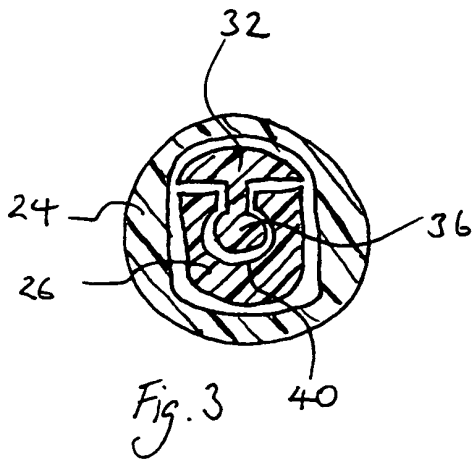

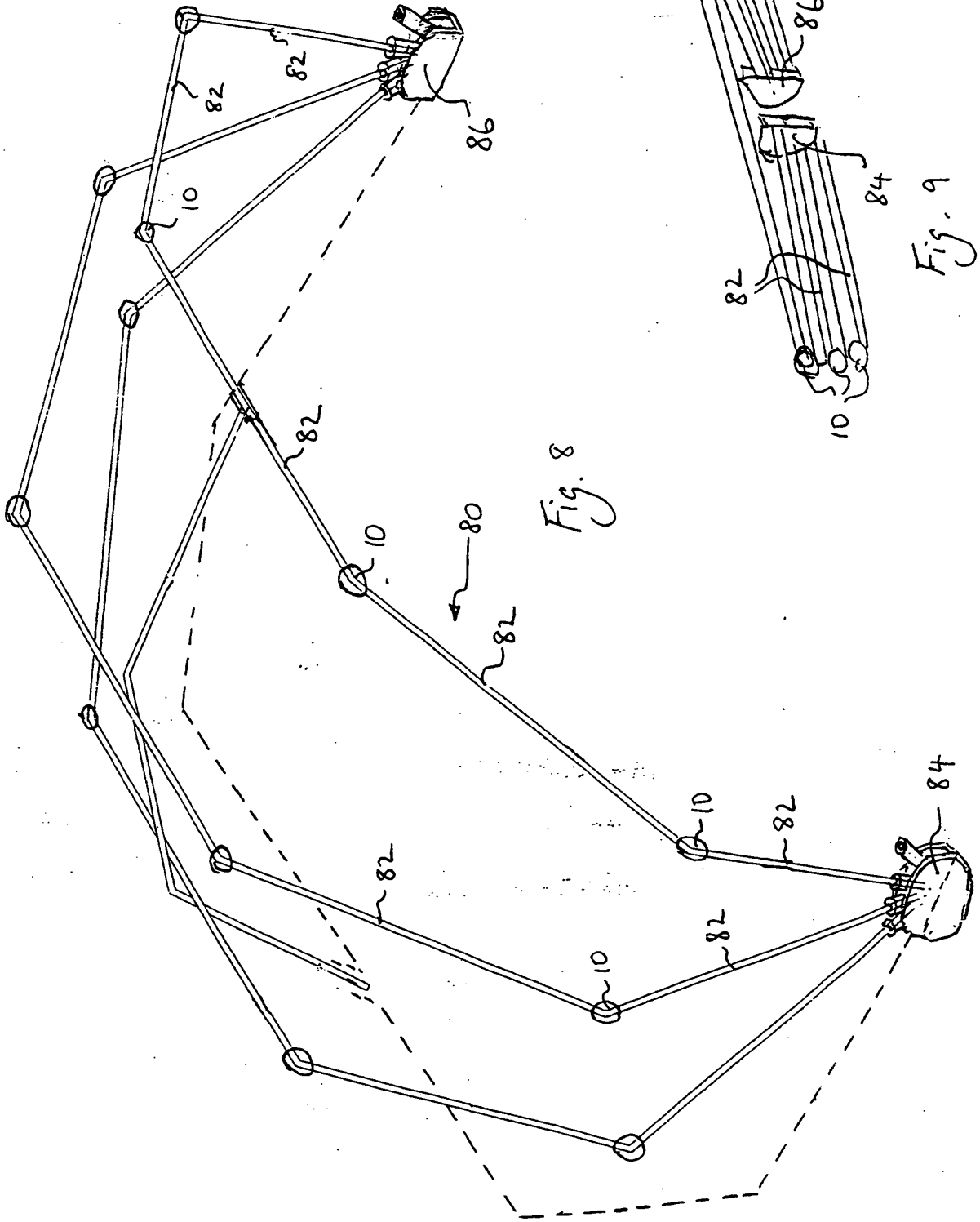

**REFERENCES CITED IN THE DESCRIPTION**

*This list of references cited by the applicant is for the reader's convenience only. It does not form part of the European patent document. Even though great care has been taken in compiling the references, errors or omissions cannot be excluded and the EPO disclaims all liability in this regard.*

**Patent documents cited in the description**

- EP 0684355 A [0001]
- EP 0704586 A [0001]
- US 4750509 A [0001]
- EP 1310616 A [0003]