

(19) World Intellectual Property
Organization
International Bureau



(43) International Publication Date
17 June 2004 (17.06.2004)

PCT

(10) International Publication Number
WO 2004/049971 A2

- (51) International Patent Classification⁷: A61F (81) Designated States (*national*): AE, AG, AL, AM, AT, AU, AZ, BA, BB, BG, BR, BY, BZ, CA, CH, CN, CO, CR, CU, CZ, DE, DK, DM, DZ, EC, EE, EG, ES, FI, GB, GD, GE, GH, GM, HR, HU, ID, IL, IN, IS, JP, KE, KG, KP, KR, KZ, LC, LK, LR, LS, LT, LU, LV, MA, MD, MG, MK, MN, MW, MX, MZ, NI, NO, NZ, OM, PG, PH, PL, PT, RO, RU, SC, SD, SE, SG, SK, SL, SY, TJ, TM, TN, TR, TT, TZ, UA, UG, UZ, VC, VN, YU, ZA, ZM, ZW.
- (21) International Application Number: PCT/US2003/038636
- (22) International Filing Date: 3 December 2003 (03.12.2003)
- (25) Filing Language: English
- (26) Publication Language: English (84) Designated States (*regional*): ARIPO patent (BW, GH, GM, KE, LS, MW, MZ, SD, SL, SZ, TZ, UG, ZM, ZW), Eurasian patent (AM, AZ, BY, KG, KZ, MD, RU, TJ, TM), European patent (AT, BE, BG, CH, CY, CZ, DE, DK, EE, ES, FI, FR, GB, GR, HU, IE, IT, LU, MC, NL, PT, RO, SE, SI, SK, TR), OAPI patent (BF, BJ, CF, CG, CI, CM, GA, GN, GQ, GW, ML, MR, NE, SN, TD, TG).
- (30) Priority Data: 10/310,675 4 December 2002 (04.12.2002) US
- (71) Applicant: ESTECH, INC. (ENDOSCOPIC TECHNOLOGIES, INC.) [US/US]; 4135 Blackhawk Plaza Circle, Suite 150, Danville, CA 94056 (US).
- (72) Inventor: BERTOLERO, Art; 155 Sunhaven Road, Danville, CA 94056 (US).
- (74) Agents: HESLIN, James, M. et al.; Townsend And Townsend And Crew LLP, Two Embarcadero Center, 8th Floor, San Francisco, CA 94111-3834 (US).
- Published:
— without international search report and to be republished upon receipt of that report
- For two-letter codes and other abbreviations, refer to the "Guidance Notes on Codes and Abbreviations" appearing at the beginning of each regular issue of the PCT Gazette.

(54) Title: METHODS AND DEVICES FOR MINIMALLY INVASIVE CARDIAC SURGERY FOR ATRIAL FIBRILLATION

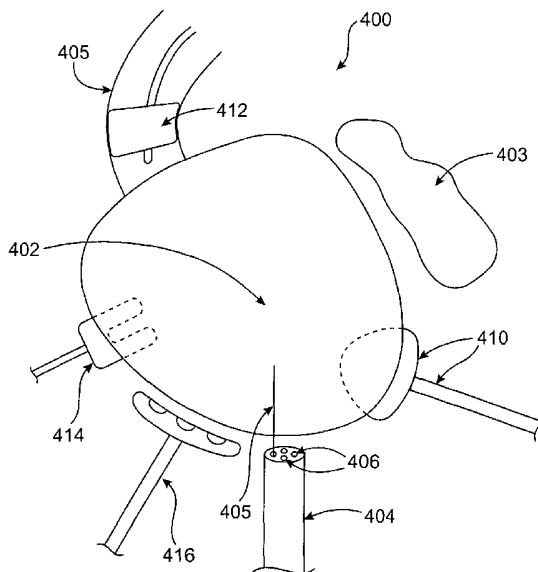

(57) Abstract: Devices for enhancing minimally invasive cardiac surgery include a visualization device including an inflatable balloon at or near the distal end. Some visualization devices also include one or more lumens for allowing the introduction of one or more devices to a surgical site through the visualization device. Systems of the invention involve a visualization device which has at least one lumen for allowing introduction of an ablation device and/or other devices. A visualization device with an inflatable balloon may be positioned to create a space between a heart and pericardium when the balloon is inflated.

WO 2004/049971 A2

METHODS AND DEVICES FOR MINIMALLY INVASIVE CARDIAC SURGERY FOR ATRIAL FIBRILLATION

BACKGROUND OF THE INVENTION

[0001] The present invention relates generally to medical devices and methods. More specifically, the invention relates to devices and methods for enhancing minimally invasive cardiac surgery of atrial fibrillation.

[0002] Atrial fibrillation (AF) is a heart beat rhythm disorder (or "cardiac arrhythmia") in which the upper chambers of the heart known as the atria quiver rapidly instead of beating in a steady rhythm. This rapid quivering reduces the heart's ability to properly function as a pump. AF is characterized by circular waves of electrical impulses that travel across the atria in a continuous cycle. It is the most common clinical heart arrhythmia, affecting more than two million people in the United States and some six million people worldwide.

[0003] Atrial fibrillation typically increases the risk of acquiring a number of potentially deadly complications, including thrombo-embolic stroke, dilated cardiomyopathy and congestive heart failure. Quality of life is also impaired by common AF symptoms such as palpitations, chest pain, dyspnea, fatigue and dizziness. People with AF have, on average, a five-fold increase in morbidity and a two-fold increase in mortality compared to people with normal sinus rhythm. One of every six strokes in the U.S. (some 120,000 per year) occurs in patients with AF, and the condition is responsible for one-third of all hospitalizations related to cardiac rhythm disturbances (over 360,000 per year), resulting in billions of dollars in annual healthcare expenditures.

[0004] AF is the most common arrhythmia seen by physicians, and the prevalence of AF is growing rapidly as the population ages. The likelihood of developing AF increases dramatically as people age; the disorder is found in about 1% of the adult population as a whole, and in about 6% of those over age 60. By age 80, about 9% of people (one in 11) will have AF. According to a recent statistical analysis, the prevalence of AF in the U.S. will more than double by the year 2050, as the proportion of elderly increases. A recent study called The Anticoagulation and Risk Factors in Atrial Fibrillation (ATRIA) study, published in the Spring of 2001 in the Journal of the American Medical Association (JAMA), found that 2.3 million U.S. adults currently have AF and this number is likely to increase over the next 50 years to more than 5.6 million, more than half of whom will be age 80 or over.

[0005] As the prevalence of AF increases, so will the number of people who develop debilitating or life-threatening complications, such as stroke. According to Framingham Heart Study data, the stroke rate in AF patients increases from about 3% of those aged 50-59 to more than 7% of those aged 80 and over. AF is responsible up to 35% of the strokes that occur in people older than age 85.

[0006] Efforts to prevent stroke in AF patients have so far focused primarily on the use of anticoagulant and antiplatelet drugs, such as warfarin and aspirin. Long-term warfarin therapy is recommended for all AF patients with one or more stroke risk factors, including all patients over age 75. Studies have shown, however, that warfarin tends to be under-prescribed for AF. Despite the fact that warfarin reduces stroke risk by 60% or more, only 40% of patients age 65-74 and 20% of patients over age 80 take the medication, and probably fewer than half are on the correct dosage. Patient compliance with warfarin is problematic, and the drug requires vigilant blood monitoring to reduce the risk of bleeding complications.

[0007] Electrophysiologists classify AF by the “three Ps”: paroxysmal, persistent, or permanent. Paroxysmal AF—characterized by sporadic, usually self-limiting episodes lasting less than 48 hours—is the most amenable to treatment, while persistent or permanent AF is much more resistant to known therapies. Researchers now know that AF is a self-perpetuating disease and that abnormal atrial rhythms tend to initiate or trigger more abnormal rhythms. Thus, the more episodes a patient experiences and the longer the episodes last, the less chance of converting the heart to a persistent normal rhythm, regardless of the treatment method.

[0008] AF is characterized by circular waves of electrical impulses that travel across the atria in a continuous cycle, causing the upper chambers of the heart to quiver rapidly. At least six different locations in the atria have been identified where these waves can circulate, a finding that paved the way for maze-type ablation therapies. More recently, researchers have identified the pulmonary veins as perhaps the most common area where AF-triggering foci reside. Technologies designed to isolate the pulmonary veins or ablate specific pulmonary foci appear to be very promising and are the focus of much of the current research in catheter-based ablation techniques.

[0009] Although cardiac ablation devices and methods are currently available, many advances may still be made to provide improved devices and methods for ablating epicardial tissue to treat AF and other arrhythmias. For example, currently available devices can be difficult to position and secure on epicardial tissue to perform an ablation. Devices such as bipolar ablation clamps and others can ablate tissue only in very limited patterns, such as one

or two straight lines. Ablation devices often have no means for shielding ablative energy, to avoid unwanted burning of tissues in the vicinity of the heart, such as the esophagus.

Relatively few devices can be secured to epicardial tissue with sufficient force to allow for stabilization of the heart. And many ablation devices may not be introduced by minimally
5 invasive means, thus requiring an open surgical procedure. Typically, therefore, current cardiac ablation procedures for AF treatment still require stopping the heart and using a cardiopulmonary bypass apparatus. Many of these shortcomings are addressed by devices and methods described in co-pending U.S. Patent Application Serial No. 10/272446, filed by the inventor of the present application on October 15, 2002, the full disclosure of which is
10 hereby incorporated by reference.

[0010] Another shortcoming in currently available surgical techniques is the difficulty of gaining optimal visualization of a surgical site on the heart and/or of structures in and around the surgical site. In other words, gaining sufficient visualization to allow the surgeon to accurately manipulate, ablate or otherwise operate on the heart is sometimes challenging
15 using current methods and devices. Positioning a visualization device, for example between pericardial tissue and the outer surface of the heart, and maintaining the position of the device for visualizing an ablation procedure can often be difficult using currently available devices and techniques. Oftentimes, visualization devices and surgical instruments collide or simply overcrowd a surgical site, reducing a surgeon's room to work in and visualize the surgical
20 site.

[0011] Therefore, a need exists for devices, systems and methods for enhancing minimally invasive cardiac surgery to treat AF and other cardiac arrhythmias. Preferably, such devices and methods would provide improved visualization of the heart and/or to an area around the heart where a surgical procedure is being performed. Also preferably, such visualization
25 devices and methods would provide improved visualization without crowding the surgical site. Further, it would be desirable for such methods and devices to be minimally invasive. At least some of these objectives will be met by the present invention.

BRIEF SUMMARY OF THE INVENTION

[0012] The present invention generally provides improved methods, devices and systems
30 for minimally invasive cardiac surgery, such as surgery to treat atrial fibrillation. In one aspect, a method for enhancing visualization of a surgical procedure on a heart of a patient comprises: introducing an elongate visualization device into the patient; advancing the visualization device to position at least one inflatable balloon on the visualization device

between the heart and a layer of pericardium adjacent the heart; inflating the at least one inflatable balloon; and using the visualization device to visualize the heart during the surgical procedure. Introducing the visualization device may be accomplished through any suitable incision, such as a subzyphoid incision, a subcostal incision or a thoracotomy. Advancing the visualization device may include advancing the device through the layer of pericardium.

Inflating at least one balloon may include inflating one balloon disposed around a circumference of the visualization device. In another embodiment, inflating at least one balloon comprises inflating at least two balloons disposed around a circumference of the visualization device, wherein one balloon is located between the heart and the layer of pericardium and the other balloon is located proximal to the pericardium.

[0013] In some embodiments, the method further includes protecting an optical element of the visualization device by using the balloon to reduce contact of the optical element with other structures. Some embodiments may also include cleaning the optical element by introducing a fluid through a lumen in the visualization device to contact the optical element.

A method may further include introducing an ablation device through a first lumen in the visualization device to contact the heart. Additionally, in some embodiments, the method includes introducing at least one of a clamp, a positioning device, a stabilization device, a cutting device, a cardiac mapping device, a catheter, a left atrial appendage clip applicator, an insufflation device and an irrigation device through at least a second lumen in the visualization device. The method may also include: ablating the heart, using the ablation device; removing the ablation device from the first lumen; introducing a left atrial appendage clip applicator through the first lumen to contact a left atrial appendage of the heart; and applying at least one clip to the left atrial appendage. In some embodiments, the method also includes providing light to the visualization device from a control unit; and providing ablation energy to the ablation device from the control unit. Optionally, the method may include providing at least one of insufflation and irrigation to the visualization device from the control unit. Also optionally, the method may comprise recording at least one image acquired by the visualization device on the control unit.

[0014] In another aspect, a visualization device for enhancing minimally invasive heart surgery comprises an elongate visualization member having a proximal end and a distal end and at least one inflatable balloon coupled with the visualization member at or near the distal end. In some embodiments, for example the visualization member comprises an endoscope. Alternatively, the visualization member is selected from the group consisting of an ultrasound device, a fluoroscopy device, an MRI device and a stereotactic positioning device. In some

embodiments, the proximal end of the visualization member is removably couplable with an image viewing device. In many embodiments, the device further includes means for inflating the at least one inflatable balloon. For example, the means for inflating may include an infusion lumen for infusing at least one of air or a fluid into the at least one inflatable balloon.

5 The at least one balloon may comprise a first balloon disposed around a circumference of the visualization device such that when the first balloon is inflated it creates a space between a pericardial layer around a heart and an outer surface of the heart. Optionally, the at least one balloon may further comprise a second balloon disposed around the circumference of the visualization device at a location proximal to the first balloon. In some embodiments, the
10 first balloon, when inflated, at least partially protects an optical element of the visualization device from harm due to contact.

[0015] In some embodiments, the visualization device also includes a first lumen for allowing passage of an ablation device. Optionally, the device may include at least a second lumen for allowing passage of at least one of a clamp, a positioning device, a stabilization
15 device, a cutting device, a cardiac mapping device, a catheter, a left atrial appendage clip applier, an insufflation device and an irrigation device. In some embodiments, the device includes an irrigation lumen for introducing a cleaning fluid to contact and clean an optical element of the visualization device.

[0016] In yet another aspect, a clip applier for applying at least one clip to a left atrial
20 appendage of a heart of a patient comprises: an elongate shaft defining a proximal end and a distal end; clip applying means coupled with the shaft at or near the distal end; and an actuator coupled with the shaft at or near the distal end and also coupled with the clip applying means so as to actuate the applying means to apply the at least one clip to the left atrial appendage. In some embodiments, the device is introducible through a lumen of a
25 visualization device. Optionally, the clip applier may further include at least one clip coupled with the device in a position to allow the clip applying means to apply the clip to the atrial appendage. In some embodiments, the at least one clip does not sever the atrial appendage when applied to the appendage by the clip applying means.

[0017] In still another aspect, a system for performing an ablation procedure on a heart of a
30 patient comprises: a visualization device comprising an elongate visualization member having a proximal end and a distal end and at least one inflatable balloon coupled with the visualization member at or near the distal end; and an ablation device for ablating a portion of the heart. The visualization member, for example, may comprise an endoscope. In other embodiments, the visualization member is selected from the group consisting of an

ultrasound device, a fluoroscopy device, an MRI device and a stereotactic positioning device. In some embodiments, the proximal end of the visualization member is removably coupleable with an image viewing device. In all other aspects, the visualization device may have any of the features described above or any other suitable features.

5 [0018] In some embodiments, the system further includes a left atrial appendage clip applicator for applying at least one clip to the left atrial appendage to reduce or stop blood flow through the appendage. Also optionally, the system may include a heart positioning device for moving the heart into a desired position. For example, the heart positioning device may include an elongate shaft defining a proximal end and a distal end and an inflatable
10 positioning member coupled with the shaft at or near the distal end. The inflatable positioning member, for example, may be coupled with the shaft via a flexible joint selected from the group consisting of a ball and socket joint and a ball and collet joint. In other embodiments, the system includes at least one retractor device for facilitating introduction of the visualization device. Optionally, the at least one retractor device includes at least one
15 retractor blade having a cushioned surface for reducing damage to a nerve when the cushioned surface contacts the nerve. For example, the nerve may be an intercostal nerve when the retractor device retracts a rib of a patient.

[0019] In some embodiments, the further comprises a control unit for coupling with at least the visualization device and the ablation device. The control unit may comprise, for example,
20 a light source for providing light to the visualization device and an ablative energy source for providing ablative energy to the ablation device. In some embodiments, the control unit further comprises: a video source for coupling with the visualization device; at least one of an insufflation source and an irrigation source for providing insufflation and/or irrigation to the visualization device; and a power cord for connecting the control unit with a power source.
25 Even further, the control unit may comprise an image recorder for recording images from the visualization device. In some embodiments, the ablative energy source of the control unit provides at least one of RF energy, cryogenic energy and microwave energy.

[0020] In another aspect, a control unit for enhancing a minimally invasive surgical procedure on a heart of a patient comprises a light source for providing light to the
30 visualization device and an ablative energy source for providing ablative energy to the ablation device. As mentioned above, the control unit may further comprise a video source for coupling with the visualization device; at least one of an insufflation source and an irrigation source for providing insufflation and/or irrigation to the visualization device; and a

power cord for connecting the control unit with a power source. Any other suitable feature may be included.

BRIEF DESCRIPTION OF THE DRAWINGS

- 5 [0021] FIG. 1 is a schematic representation of a patient, showing a single-entry device for performing and viewing a cardiac surgery procedure, according to one embodiment of the present invention.
- [0022] FIG. 2 is a schematic representation of a patient, showing a multiple-entry device for performing and viewing a cardiac surgery procedure, according to one embodiment of the present invention.
- 10 [0023] FIG. 3A is a schematic side view of a visualization device for viewing a heart, according to one embodiment of the present invention.
- [0024] FIG. 3B is a schematic side view of a visualization device for viewing a heart, according to another embodiment of the present invention.
- [0025] FIG. 3C is a schematic side view of a visualization device having two inflatable
15 balloons, according to another embodiment of the present invention.
- [0026] FIG. 3D is a side view of a visualization device having an inflatable balloon, according to another embodiment of the present invention.
- [0027] FIG. 3E is a perspective view of the visualization device in FIG. 3D.
- [0028] FIG. 4 is an inferior/bottom-side view of a heart, showing multiple devices which
20 may be used to provide access, positioning and visualization of the heart, according to one embodiment of the present invention.
- [0029] FIG. 5A is a perspective view of a heart retractor, according to one embodiment of the present invention.
- [0030] FIG. 5B is a perspective view of a heart retractor, according to another embodiment
25 of the present invention.
- [0031] FIG. 5C is a perspective view of a left atrial appendage clip applying device, according to an embodiment of the present invention.
- [0032] FIG. 6A is a perspective view of a viewing device providing means for introducing an ablating device, according to one embodiment of the present invention.
- 30 [0033] FIG. 6B is a perspective view of a viewing device providing means for introducing multiple devices, according to one embodiment of the present invention.
- [0034] FIG. 7 is a frontal, schematic view of a control unit for a minimally invasive surgical system, according to one embodiment of the present invention.

DETAILED DESCRIPTION OF THE INVENTION

[0035] Devices, systems and methods of the present invention provide for enhancement of heart surgery procedures. Generally, the invention provides for enhanced visualization of a surgical site on, around or near a patient's heart via the use of one or more devices. Various
5 embodiments also provide additional features, such as improved access to the surgical site, prevention of clot dispersal from the left atrial appendage, improved heart positioning and stabilization and/or the like. The invention may be used to enhance any of a number of minimally invasive cardiac surgery procedures, such as ablation procedures for treating atrial
10 fibrillation and the like. Thus, although the description below generally relates to ablation procedures for treating atrial fibrillation, any other suitable procedure may incorporate methods, devices and/or systems of the present invention. Various embodiments of the invention may be used in procedures involving a stopped heart and cardiopulmonary bypass, partial bypass, or in beating heart procedures.

[0036] Referring now to Figure 1, a schematic view of a patient 100 is shown, with a
15 representation of a heart 102 and a visualization device 104 in position to visualize a portion of heart 102. Generally, visualization device 104 may comprise any suitable device for enhancing visualization of a surgical field and/or heart 102. For example, in some embodiments visualization device 104 comprises an endoscope, such as commercially available endoscopes or endoscopes developed in the future. Such endoscopes may be
20 flexible, rigid, or partially flexible and partially rigid. In other embodiments, any other suitable visualization devices may be used, such as ultrasound devices, fluoroscopic devices, MRI devices, stereotactic positioning devices or the like. In some embodiments, visualization device includes at least one inflatable balloon 107 at or near its distal end. As will be described further below, balloon 107 may enhance visualization with visualization
25 device 104, protect optical elements of the device 104, help maintain a position of the device 104 and/or perform other functions. Typically, visualization device 104 is coupled at or near its proximal end with a control unit (not shown), for example a unit including a light source, via a connector 108. It will be understood by those skilled in the art that multiple connectors 108 may be used to couple visualization device 104 to one or more control units for multiple
30 purposes. For example, separate connectors 108 may be used for coupling with a light source, a source of insufflation, a source of irrigation, a video monitor or other image capture device and/or the like.

[0037] In some embodiments, one or more additional devices may be introduced into patient 100 via visualization device 104. For example, in one embodiment an ablation device

106 for ablating a pattern on heart 102 for treating atrial fibrillation may be introduced via visualization device 104. Often, additional devices such as ablation device 106 are introduced through one or more lumens on visualization device 104. Ablation device 106 may be any suitable ablation device, such as a radio frequency (RF) device or the like. In
5 some embodiments, ablation device may comprise one or more of the devices described in U.S. Patent Application Serial No. 10/272446, previously incorporated by reference.

Ablation device 106 is typically connected, at or near its proximal end, to a controller device (not shown), for activating an ablation member and the like. As described further below, any suitable combination of instruments, devices and the like may be introduced through access
10 device 104.

[0038] Visualization device 104 may be introduced into patient 100 via a primary incision placed in any suitable location. For example, in one embodiment the primary incision comprises a subzyphoid incision, but in other embodiments a subcostal incision, an intercostal incision or any other suitable incision may be used.

[0039] Referring now to Figure 2, in some surgical procedures, additional devices may be used and additional incisions may be made on patient 100. Generally, visualization device 104 of Figs. 1 and 2 may be introduced into the patient and advanced to the surgical site via any suitable incision, as described above. To facilitate introduction of visualization device 104, one or more retractors 210 may be used to increase the size of an incision. One or more
15 additional incisions on patient 100 may include, for example, an arterial/venous access incision 212a for providing access for a perfusion cannula to a cardiopulmonary bypass machine or for any other device, an incision for a separately-introduced left atrial appendage clamp or clip 212b, and/or a femoral incision 212c for providing access to a femoral artery for entry of a mapping catheter or any other device. Any suitable combination of incisions
20 212 and devices is contemplated within the scope of the invention.

[0040] Referring now to Figures 3A-3C, several different types of visualization devices are shown, each in relation to skin (SK), pericardium (PC) and a heart (H) of a patient (none of which are drawn to scale.) In one embodiment, with reference to Figure 3A, a visualization device 304 is coupled with an insertion needle 302, which comprises a thin, elongate needle-
25 like device or sheath-like device for aiding delivery of visualization device 304 to a desired location. Insertion needle 302 is typically a small-profile device, perhaps between 1-3 mm, to allow for minimally invasive introduction of visualization device 304. Figure 3B shows a visualization device 310 configured for introduction through a trocar 312 or other, similar introducer sheath or device. In some embodiments, visualization device 310 includes both a

visualization member 305 and one or more lumens 314 for allowing introduction of ablation devices or the like.

[0041] As shown in Figure 3C, another embodiment of a visualization device 330 may be used in conjunction with one or more retractors 320 for facilitating entry of visualization
5 device 330 into the patient. Retractors 320 may comprise any suitable retractor devices. In one embodiment, retractors 320 include one or more hinges to help retractors 320 conform to a body surface. In another embodiment, retractor blades include a pliant, cushioning or otherwise trauma-reducing surface for reducing damage to a nerve with which retractor 320 comes in contact. Any suitable retractors 320 and retractor blades are contemplated. In some
10 embodiments, visualization device 330 also includes one or more inflatable balloons 322 disposed along its outer surface. Inflatable balloons 322 are typically located at or near the distal end of visualization device 303, such that when inflatable balloons 322 are inflated at least one balloon 322 is located between heart H and pericardium PC. Balloon 322 may thus create a space between heart H and pericardium PC to facilitate visualization of heart H. One
15 or more balloons 322 may also partially or completely cover visualization member 305 to protect one or more optical elements of the member 305. In some embodiments, balloon(s) 322 also help maintain visualization device in a desired location. Generally, inflatable balloons 322 may have any desired configuration and may be inflated via any suitable means, such as by an inflation lumen in visualization device 330 coupled with a source of air or other
20 inflation medium.

[0042] Referring now to Figures 3D and 3E, a side view and a perspective view of a distal end of a visualization device 340 with an inflatable balloon 342 are shown, respectively. As can be seen from these views, balloon 342 may be configured to cover or otherwise protect an optical element 344 of visualization device 340. In this example, optical elements 344 are
25 recessed from the distal end of balloon 342, as shown by the shaded surface in Figure 3E. As should be understood by those skilled in the art, any other configuration of inflatable balloon 342, or any combination of balloons, may be used without departing from the scope of the invention.

[0043] With reference now to Figure 4, a schematic representation of a surgical site is
30 shown from the perspective of an inferior heart surface 402. A surgical system 400 for performing heart surgery according to the present invention may include multiple devices. Typically, at least one visualization device 404 will be used, in some embodiments having one or more lumens 406 for introducing one or more additional devices to the surgical site. Thus, additional devices may be introduced through lumen(s) in visualization device 404, but

they may alternatively be introduced through separate incisions, or through both visualization device 404 and separate incisions. For example, an ablation device 405 may be introduced through visualization device 404, as described above. Other devices may be introduced either separately or through visualization device. Such devices include a device for deflating the left lung 403 (device not shown) to allow greater access to and visibility of the heart 402. Additionally, one or more catheters 412 may be used to decompress the heart 402, for example by partially or completely blocking one or more blood vessels such as the aorta 405. An inflatable positioning device 410 may be used to position the heart 402, a heart retractor 414 may be further used to position the heart 414, and one or more stabilizers 416 may be used to maintain a position of the heart.

[0044] It should be understood, from Figure 4, that any suitable combination of devices, introduced into a patient via any suitable combination of minimally invasive incisions, is contemplated within the scope of the present invention. One embodiment, for example, may employ one or more ablation devices described in U.S. Patent Application Serial No.

10/272446, previously incorporated by reference. Some embodiments may use retractors as described in U.S. Patent No. 6,309,349, entitled "Surgical Retractor and Stabilizing Device and Method for Use," the entire disclosure of which is hereby incorporated by reference. Any other suitable devices may be used along with visualization device 404 to enhance minimally invasive surgery on the heart 402 via surgical system 400.

[0045] Referring now to Figure 5A, one of the devices in surgical system 400 may include a heart retractor 500. Heart retractor 500 suitably includes a retracting surface 502 coupled with an elongate shaft 540 via a flexible connector 506 such as a ball and socket joint or ball and collet joint. Elongate shaft 540 may be coupled at its proximal end with a rapid disconnect coupling mechanism 508. Rapid disconnect 508 may, in turn, comprise a flexible segment 510 for enhancing maneuverability. In one embodiment, rapid disconnect 508 may be coupled, at its proximal end, with a stable structure, such as an arm of an operating table, to maintain the position of the heart retractor 500.

[0046] With reference to Figure 5B, another device which may be used with surgical system 400 comprises an inflatable heart retractor 520 or "pillow retractor." Inflatable retractor 520 comprises an inflatable retractor surface 522, coupled with an elongate shaft 528 via a flexible connector 526. Again, shaft 528 is coupled with a rapid disconnect 530, which may or may not include a flexible segment 532. Inflatable retractor 520 also includes means for inflating the retractor surface 522, which may comprise, for example, an inflation cannula 524 within or outside of elongate shaft 528. Inflatable heart retractor 520 may be

particularly advantageous in positioning the heart by placing the inflatable surface 522 in contact with a posterior portion of the heart and inflating the surface 522 to move the heart in an anterior direction--i.e., closer to the surgeon. Creating a space behind the heart may be very advantageous in visualizing the back of the heart and/or in maneuvering one or more surgical devices to operate on the back of the heart.

5 [0047] With reference now to Figure 5C, one device which may be introduced via a visualization device of the invention or via a separate incision on a patient comprises a left atrial appendage clip applicator 630. Clip applicator 630 is typically used to apply one or more clips to the left atrial appendage of the heart to prevent clots from the left atrial appendage from embolizing and causing harm to the patient, such as a stroke. Clip applicator 630 suitably includes a clamp 632 or other means for applying a clip 634, coupled with an elongate shaft 636, which in turn is coupled with a handle 638 for operating the clamp 632. Clip applicator 630 will generally have a shape and profile which will allow it to be introduced either through a visualization device of the present invention or via a separate incision. Clips 634 are typically configured to segregate the left atrial appendage without severing the appendage, but otherwise any suitable configuration is contemplated, such as a U-shaped clip or the like. In one embodiment, clip applicator 630 may be used to simultaneously clip and excise the atrial appendage.

10 [0048] Referring now to Figure 6A, another embodiment of a visualization device 601 is shown. Again, as has been described above, viewing device comprises often a scope, such as an endoscope, and includes an optical or visualization element 604 and one or more connectors 605 for connecting to a light source and/or other devices. Visualization device 601 also includes at least one inflatable balloon 607, as discussed above, for enhancing visualization and/or for protecting optical element 604. In many embodiments, visualization device 601 also includes one or more lumens for allowing introduction of an ablation device or any other suitable device(s). In some embodiments, such as the embodiment in Figure 6A with one lumen, the profile of visualization device 601 may be quite small. For example, the device 601 may have an outer diameter of between about 1 mm and about 3 mm.

15 [0049] In another embodiment, as shown in Figure 6B, a visualization device 612 may have multiple lumens 614 for allowing introduction of multiple devices. Again, a balloon 615 and an optical element 616 will be included. Multiple lumens 614 may provide means for passage, for example, of a clamp 618 or positioning device, an ablation device 620, cutting apparatus 622, an irrigation or insufflation cannula 624, a mapping catheter 626, or any other suitable device.

[0050] Finally, with reference now to Figure 7, many of the devices in surgical system 400 described above may be coupled with a common control unit 800. Control unit 800, for example, may include a power switch 802, an outlet for a light cable 804, a light intensity meter 806, an outlet for a video cable 808, an electrical signal mapping component 810, an ablation source outlet 812 for connecting to an ablation device 814, an insufflation/irrigation outlet for coupling with an insufflation/irrigation cannula 816 and a power cord 818 for coupling control unit 800 with an external power source. Thus, a visualization device, for example, may be coupled with control unit 800 via video cable 808 and light cable 804, an ablation device 814 may be coupled with control unit 812 to receive ablative energy, such as RF energy, and multiple other devices and functions may be controlled via control unit. It will be understood by those skilled in the art that other devices and functions, such as any of the devices described above or any other suitable devices, may be coupled with control unit 800 in various embodiments.

[0051] Although the invention has been fully described above, in relation to various exemplary embodiments, various additions or other changes may be made to the described embodiments without departing from the scope of the present invention. Thus, the foregoing description has been provided for exemplary purposes only and should not be interpreted to limit the scope of the invention as set forth in the following claims.

WHAT IS CLAIMED IS:

- 1 1. A method for enhancing visualization of a surgical procedure on a
2 heart of a patient, the method comprising:
3 introducing an elongate visualization device into the patient;
4 advancing the visualization device to position at least one inflatable balloon on
5 the visualization device between the heart and a layer of pericardium adjacent the heart;
6 inflating the at least one inflatable balloon; and
7 using the visualization device to visualize the heart during the surgical
8 procedure.
- 1 2. A method as in claim 1, wherein introducing the visualization device
2 comprises introducing the device through one of a subzyphoid incision, a subcostal incision
3 and a thoracotomy.
- 1 3. A method as in claim 1, wherein advancing the visualization device
2 comprises advancing the device through the layer of pericardium.
- 1 4. A method as in claim 1, wherein inflating at least one balloon
2 comprises inflating one balloon disposed around a circumference of the visualization device.
- 1 5. A method as in claim 1, wherein inflating at least one balloon
2 comprises inflating at least two balloons disposed around a circumference of the visualization
3 device, wherein one balloon is located between the heart and the layer of pericardium and the
4 other balloon is located proximal to the pericardium.
- 1 6. A method as in claim 1, further comprising protecting an optical
2 element of the visualization device by using the balloon to reduce contact of the optical
3 element with other structures.
- 1 7. A method as in claim 6, further comprising cleaning the optical
2 element by introducing a fluid through a lumen in the visualization device to contact the
3 optical element.
- 1 8. A method as in claim 1, further comprising introducing an ablation
2 device through a first lumen in the visualization device to contact the heart.

1 9. A method as in claim 8, further comprising introducing at least one of
2 a clamp, a positioning device, a stabilization device, a cutting device, a cardiac mapping
3 device, a catheter, a left atrial appendage clip applier, an insufflation device and an irrigation
4 device through at least a second lumen in the visualization device.

1 10. A method as in claim 8, further comprising:
2 ablating the heart, using the ablation device;
3 removing the ablation device from the first lumen;
4 introducing a left atrial appendage clip applier through the first lumen to
5 contact a left atrial appendage of the heart; and
6 applying at least one clip to the left atrial appendage.

1 11. A method as in claim 8, further comprising:
2 providing light to the visualization device from a control unit; and
3 providing ablation energy to the ablation device from the control unit.

1 12. A method as in claim 11, further comprising providing at least one of
2 insufflation and irrigation to the visualization device from the control unit.

1 13. A method as in claim 11, further comprising recording at least one
2 image acquired by the visualization device on the control unit.

1 14. A visualization device for enhancing minimally invasive heart surgery,
2 the visualization device comprising:
3 an elongate visualization member having a proximal end and a distal end; and
4 at least one inflatable balloon coupled with the visualization member at or near
5 the distal end.

1 15. A visualization device as in claim 14, wherein the visualization
2 member comprises an endoscope.

1 16. A visualization device as in claim 14, wherein the visualization
2 member is selected from the group consisting of an ultrasound device, a fluoroscopy device,
3 an MRI device and a stereotactic positioning device.

1 17. A visualization device as in claim 14, wherein the proximal end of the
2 visualization member is removably couplable with an image viewing device.

1 18. A visualization device as in claim 14, further comprising means for
2 inflating the at least one inflatable balloon.

1 19. A visualization device as in claim 18, wherein the means for inflating
2 comprises an infusion lumen for infusing at least one of air or a fluid into the at least one
3 inflatable balloon.

1 20. A visualization device as in claim 14, wherein the at least one balloon
2 comprises a first balloon disposed around a circumference of the visualization device such
3 that when the first balloon is inflated it creates a space between a pericardial layer around a
4 heart and an outer surface of the heart.

1 21. A visualization device as in claim 20, wherein the at least one balloon
2 further comprises a second balloon disposed around the circumference of the visualization
3 device at a location proximal to the first balloon.

1 22. A visualization device as in claim 20, wherein the first balloon, when
2 inflated, at least partially protects an optical element of the visualization device from harm
3 due to contact.

1 23. A visualization device as in claim 14, further comprising a first lumen
2 in the visualization device for allowing passage of an ablation device.

1 24. A visualization device as in claim 23, further comprising at least a
2 second lumen in the visualization device for allowing passage of at least one of a clamp, a
3 positioning device, a stabilization device, a cutting device, a cardiac mapping device, a
4 catheter, a left atrial appendage clip applier, an insufflation device and an irrigation device.

1 25. A visualization device as in claim 14, further comprising an irrigation
2 lumen for introducing a cleaning fluid to contact and clean an optical element of the
3 visualization device.

1 26. A clip applier for applying at least one clip to a left atrial appendage of
2 a heart of a patient, the device comprising:

3 an elongate shaft defining a proximal end and a distal end;
4 clip applying means coupled with the shaft at or near the distal end; and
5 an actuator coupled with the shaft at or near the distal end and also coupled
6 with the clip applying means so as to actuate the applying means to apply the at least one clip
7 to the left atrial appendage.

1 27. A clip applier as in claim 26, wherein the device is introducible
2 through a lumen of a visualization device.

1 28. A clip applier as in claim 26, further including at least one clip coupled
2 with the device in a position to allow the clip applying means to apply the clip to the atrial
3 appendage.

1 29. A clip applier as in claim 28, wherein the at least one clip does not
2 sever the atrial appendage when applied to the appendage by the clip applying means.

1 30. A system for performing an ablation procedure on a heart of a patient,
2 the system comprising:
3 a visualization device comprising;
4 an elongate visualization member having a proximal end and a distal
5 end; and
6 at least one inflatable balloon coupled with the visualization member at
7 or near the distal end; and
8 an ablation device for ablating a portion of the heart.

1 31. A system as in claim 30, wherein the visualization member comprises
2 an endoscope.

1 32. A system as in claim 30, wherein the visualization member is selected
2 from the group consisting of an ultrasound device, a fluoroscopy device, an MRI device and a
3 stereotactic positioning device.

1 33. A system as in claim 30, wherein the proximal end of the visualization
2 member is removably couplable with an image viewing device.

1 34. A system as in claim 30, further comprising means for inflating the at
2 least one inflatable balloon.

1 35. A system as in claim 34, wherein the means for inflating comprises an
2 infusion lumen for infusing at least one of air or a fluid into the at least one inflatable balloon.

1 36. A system as in claim 30, wherein the at least one balloon comprises a
2 first balloon disposed around a circumference of the visualization device such that when the
3 first balloon is inflated it creates a space between a pericardial layer around a heart and an
4 outer surface of the heart.

1 37. A system as in claim 36, wherein the at least one balloon further
2 comprises a second balloon disposed around the circumference of the visualization device at
3 a location proximal to the first balloon.

1 38. A system as in claim 36, wherein the first balloon, when inflated, at
2 least partially protects an optical element of the visualization device from harm due to
3 contact.

1 39. A system as in claim 30, further comprising a first lumen in the
2 visualization device for allowing passage of an ablation device.

1 40. A system as in claim 39, further comprising at least a second lumen in
2 the visualization device for allowing passage of at least one of a clamp, a positioning device,
3 a stabilization device, a cutting device, a cardiac mapping device, a catheter, a left atrial
4 appendage clip applier, an insufflation device and an irrigation device.

1 41. A system as in claim 30, further comprising an irrigation lumen for
2 introducing a cleaning fluid to contact and clean an optical element of the visualization
3 device.

1 42. A system as in claim 30, further comprising a left atrial appendage clip
2 applier for applying at least one clip to the left atrial appendage to reduce or stop blood flow
3 through the appendage.

1 43. A system as in claim 30, further comprising a heart positioning device
2 for moving the heart into a desired position.

1 44. A system as in claim 43, wherein the heart positioning device
2 comprises:

3 an elongate shaft defining a proximal end and a distal end; and
4 an inflatable positioning member coupled with the shaft at or near the distal
5 end.

1 45. A system as in claim 44, wherein the inflatable positioning member is
2 coupled with the shaft via a flexible joint selected from the group consisting of a ball and
3 socket joint and a ball and collet joint.

1 46. A system as in claim 30, further comprising at least one retractor
2 device for facilitating introduction of the visualization device.

1 47. A system as in claim 46, wherein the at least one retractor device
2 includes at least one retractor blade having a cushioned surface for reducing damage to a
3 nerve when the cushioned surface contacts the nerve.

1 48. A system as in claim 47, wherein the nerve is an intercostal nerve and
2 the retractor device retracts a rib of a patient.

1 49. A system as in claim 30, further comprising a control unit for coupling
2 with at least the visualization device and the ablation device, the control unit comprising:
3 a light source for providing light to the visualization device; and
4 an ablative energy source for providing ablative energy to the ablation device.

1 50. A system as in claim 49, wherein the control unit further comprises:
2 a video source for coupling with the visualization device;
3 at least one of an insufflation source and an irrigation source for providing
4 insufflation and/or irrigation to the visualization device; and
5 a power cord for connecting the control unit with a power source.

1 51. A system as in claim 50, wherein the control unit further comprises an
2 image recorder for recording images from the visualization device.

1 52. A system as in claim 49, wherein the ablative energy source provides
2 at least one of RF energy, cryogenic energy and microwave energy.

1 53. A control unit for enhancing a minimally invasive surgical procedure
2 on a heart of a patient, the device comprising:

3 a light source for providing light to the visualization device; and
4 an ablative energy source for providing ablative energy to the ablation device.

1 54. A control unit as in claim 53, further comprising:
2 a video source for coupling with the visualization device;
3 at least one of an insufflation source and an irrigation source for providing
4 insufflation and/or irrigation to the visualization device; and
5 a power cord for connecting the control unit with a power source.

1 55. A control unit as in claim 54, further comprising an image recorder for
2 recording images from the visualization device.

1 56. A control unit as in claim 53, wherein the ablative energy source
2 provides at least one of RF energy, cryogenic energy and microwave energy.

1

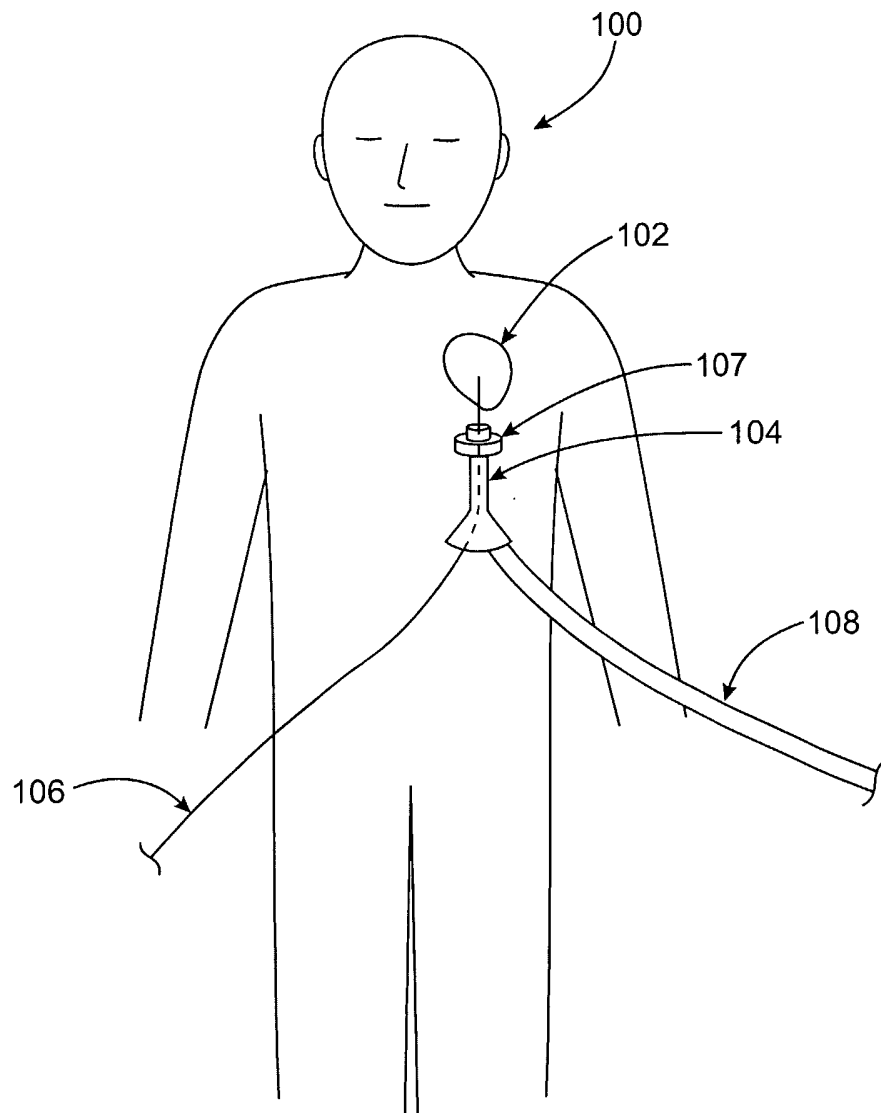

FIG. 1

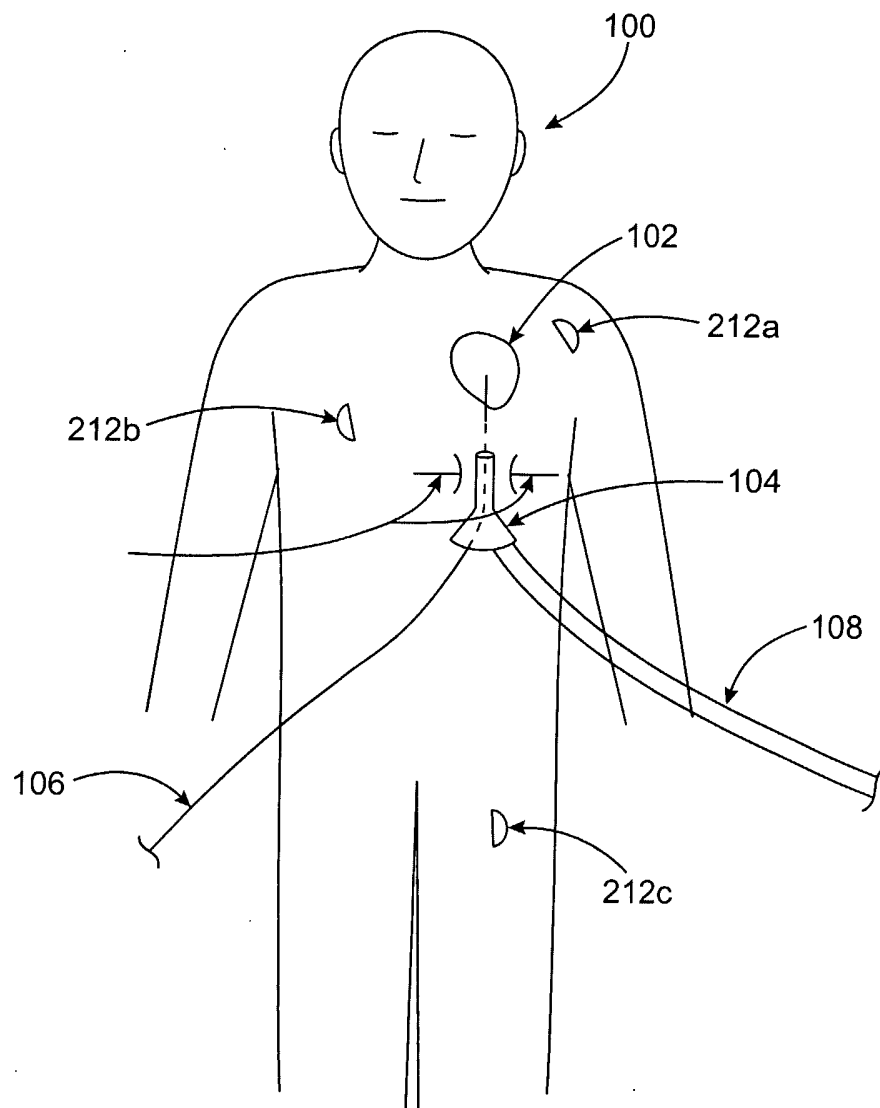
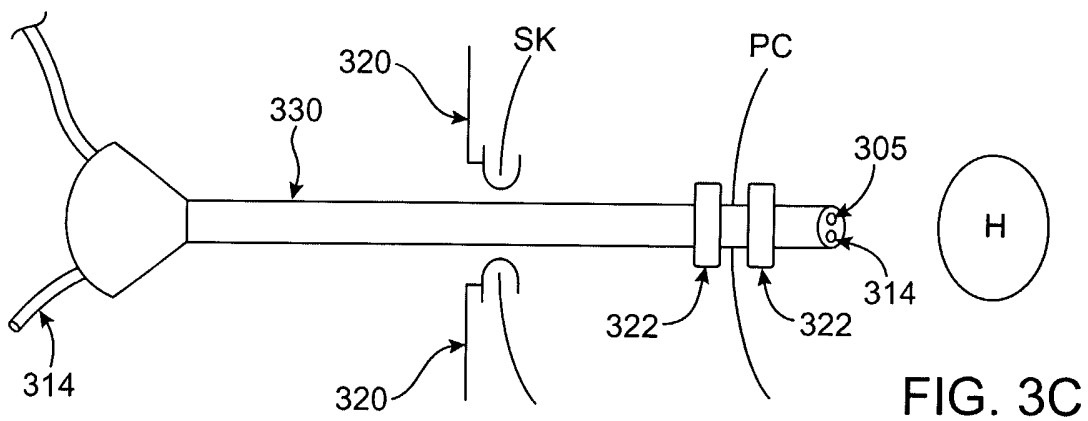
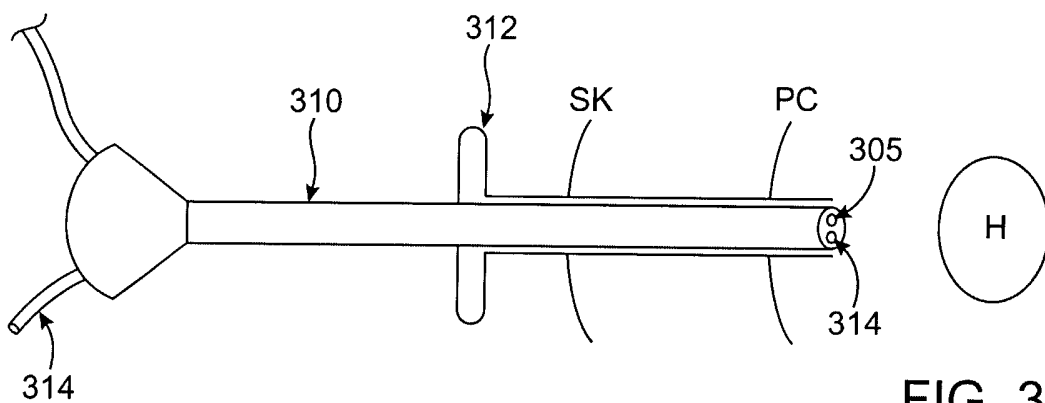
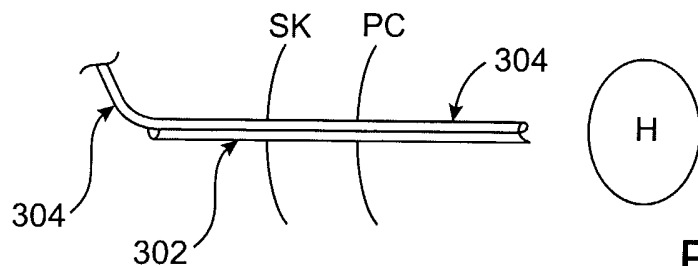

FIG. 2



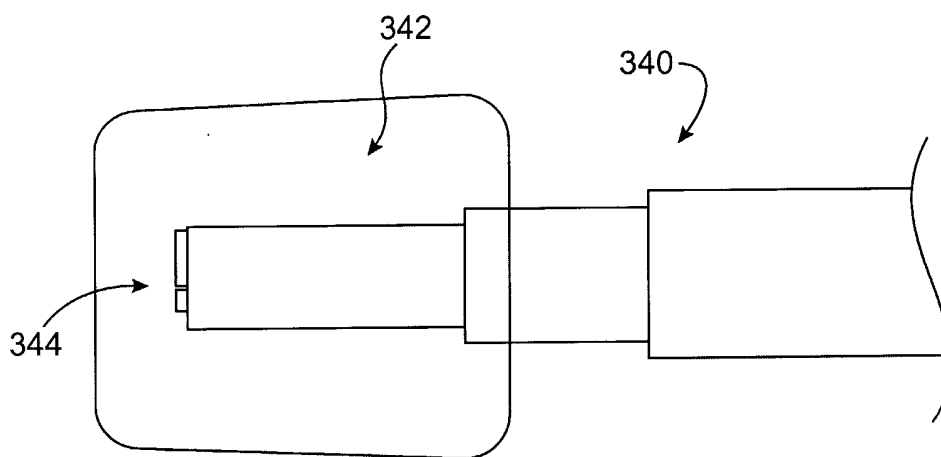

FIG. 3D

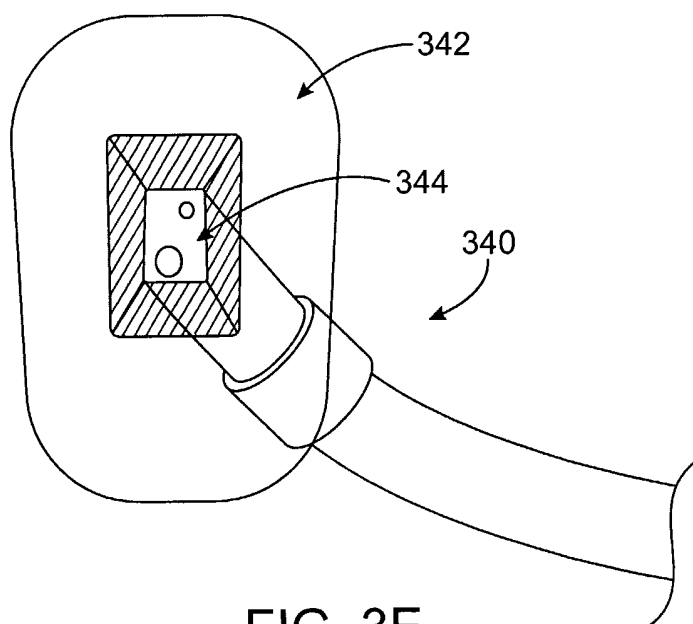

FIG. 3E

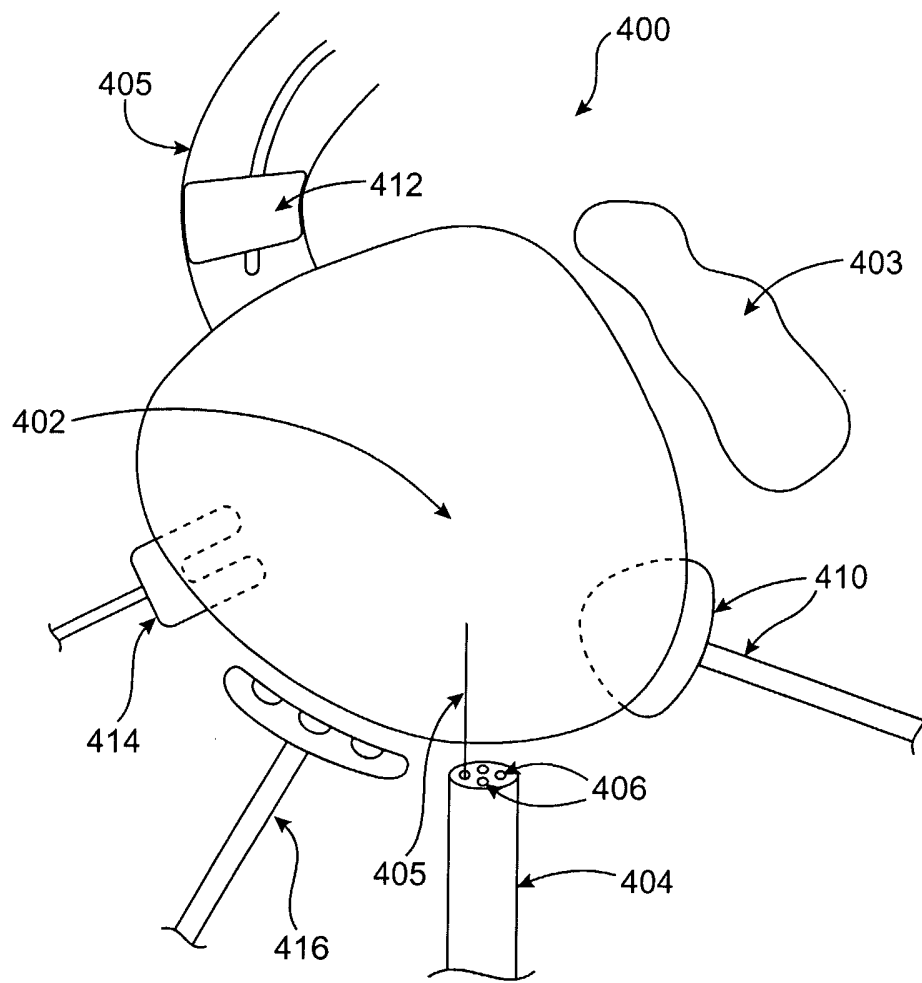

FIG. 4

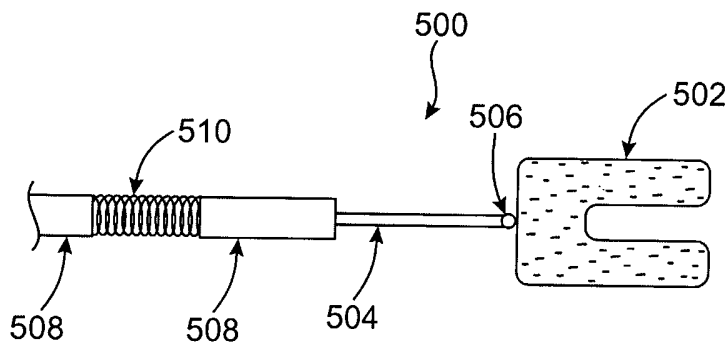

FIG. 5A

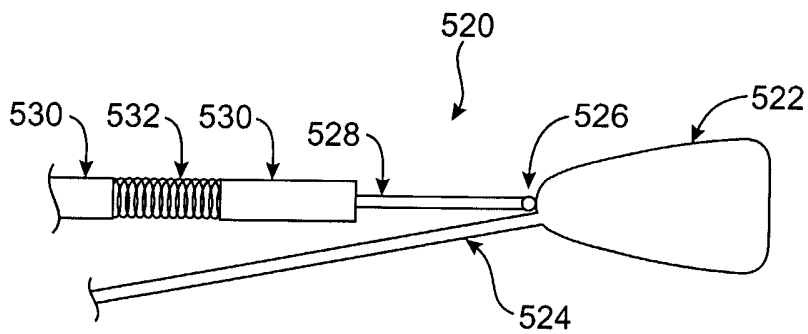

FIG. 5B

7 / 9

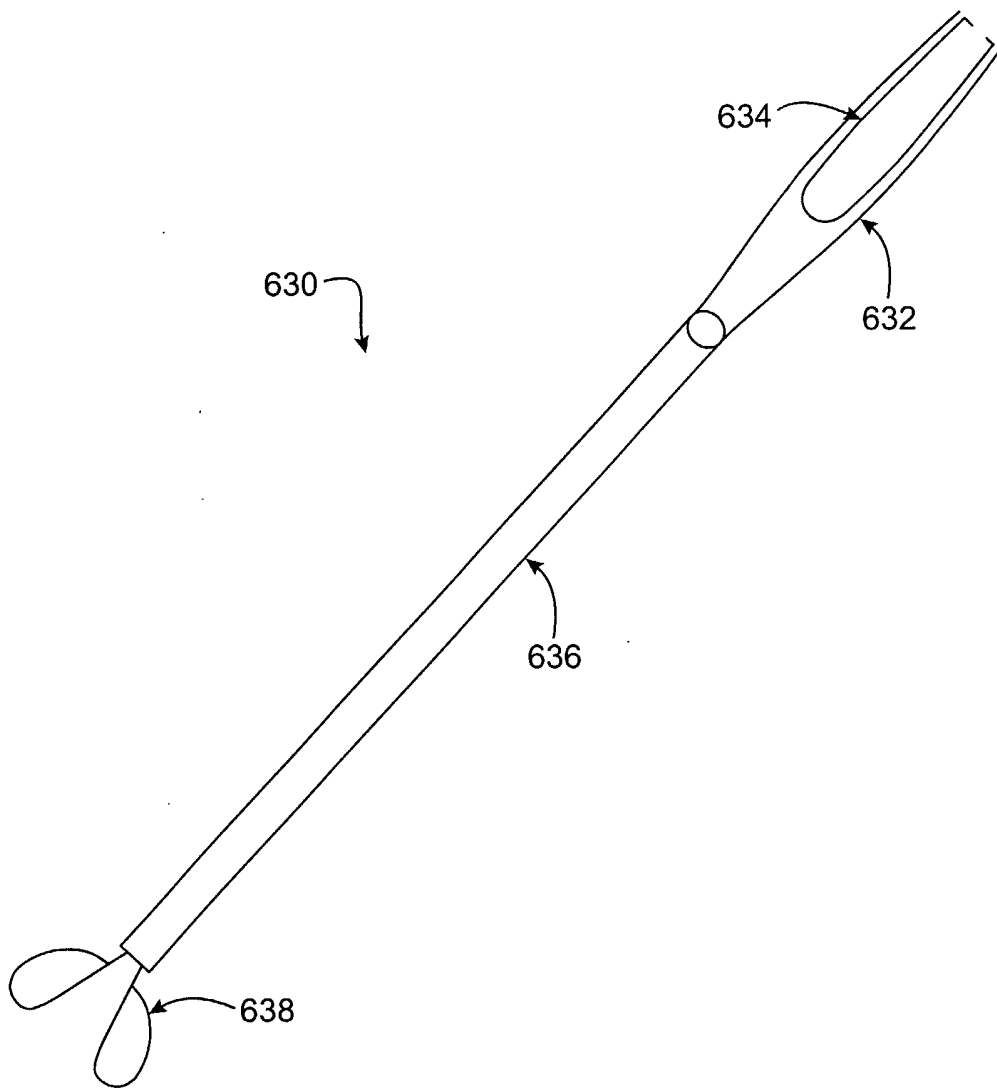

FIG. 5C

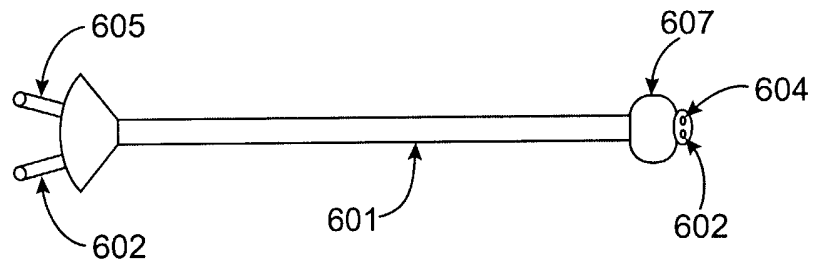

FIG. 6A

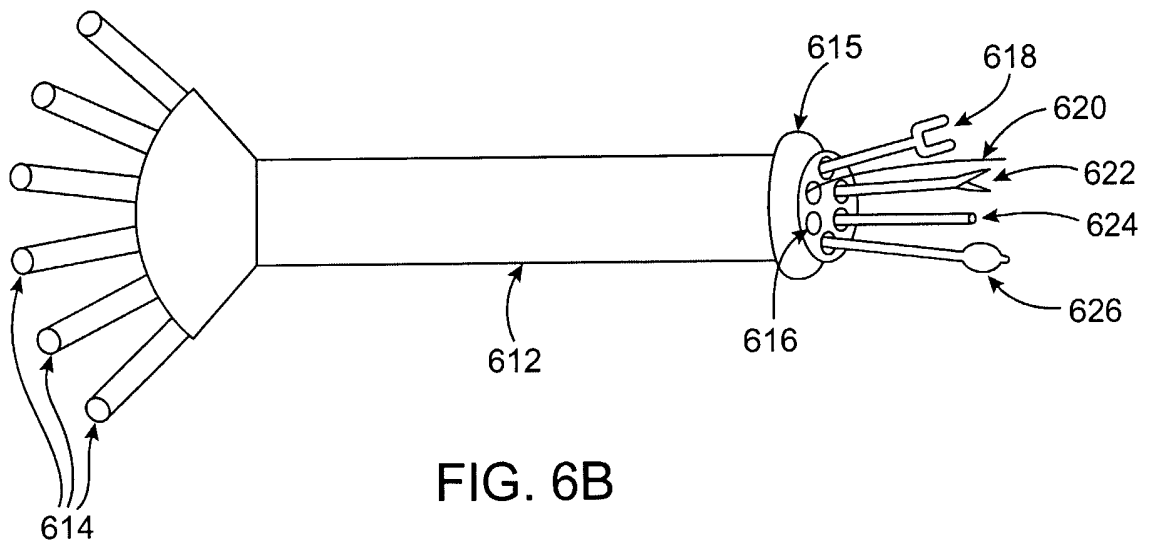

FIG. 6B

