



(11) (21) (C) **2,057,392**
(22) 1991/12/09
(43) 1992/07/10
(45) 2000/11/14

(72) Bower, Lawrence J., US
(72) Delo, Ronald R., US
(72) VanZeeland, Gerald D., US
(73) NEWELL OPERATING COMPANY, US

(51) Int.Cl.⁵ B05C 17/02, B29C 63/10

(30) 1991/01/09 (07/639,082) US

(54) **ROULEAU A PEINTURE, METHODE ET APPAREIL DE
FABRICATION DES ROULEAUX A PEINTURE**

(54) **PAINT ROLLER AND METHOD AND APPARATUS OF
MANUFACTURING A PAINT ROLLER**

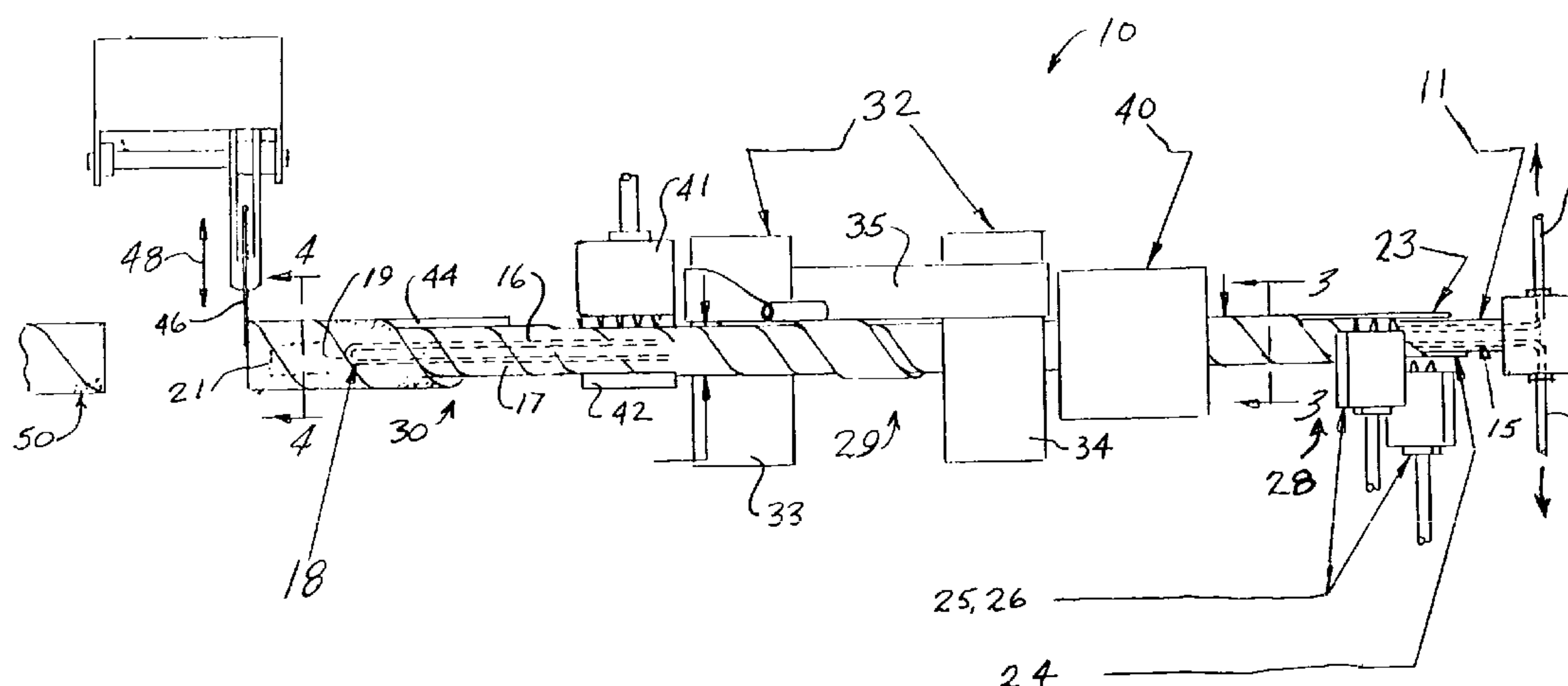

(57) A paint roller with a thermal plastic core and a method and apparatus for making such a paint roller in a continuous, low cost production method in which a tubular plastic core is formed by laying up a two-ply wrap over a mandril with surface heating only of the contacting ply surfaces to form a continuous, endless, unitary thermal plastic core structure, cooling the inside and outside surface of the core structure to a final internal diameter dimension and, following contracting of the internal core structure to a final desired diameter, heat bonding a compatible thermal plastic pile fabric to the external surface of the core structure followed by separation of the continuously produced composite structure into final pieces.



ABSTRACT**PAINT ROLLER AND METHOD AND APPARATUS
OF MANUFACTURING A PAINT ROLLER**

A paint roller with a thermal plastic core and a method and apparatus for making such a paint roller in a continuous, low cost production method in which a tubular plastic core is formed by laying up a two-ply wrap over a mandril with surface heating only of the contacting ply surfaces to form a continuous, endless, unitary thermal plastic core structure, cooling the inside and outside surface of the core structure to a final internal diameter dimension and, following contracting of the internal core structure to a final desired diameter, heat bonding a compatible thermal plastic pile fabric to the external surface of the core structure followed by separation of the continuously produced composite structure into final pieces.

Paint Roller and Method and
Apparatus of Manufacturing a Paint Roller

BACKGROUND OF THE INVENTION

Field Of The Invention

5 This invention relates generally to the field of paint
rollers and, more specifically, to a paint roller with a
thermoplastic core and a method of and apparatus for making such
a paint roller in a continuous, low cost production method. The
final product is a paint roller in which the pile fabric cover is
10 bonded directly to a thermoplastic core, the core having been
formed and the pile fabric applied in a continuous, uninterrupted
sequence of processing steps.

Background Of The Invention

15 Two methods of manufacturing pile fabric paint rollers on
thermoplastic cores are currently widely used, which methods
result in dissimilar, though usable products.

20 In the first method adhesive is applied to a previously
extruded core blank and thereafter pile fabric in strip form is
wrapped around the adhesive carrying core blank. After setting
of the adhesive, or at least the formation of a good bond between
the pile fabric and the adhesive, the core blank is cut into
pieces of the desired length which may or may not be further
processed, as by trimming the end edges of the pile fabric. This
system has several disadvantages including (a) substantial
25 expense and considerable complexity, with the resultant
opportunity for production interruption, due to the use of three
components -- core, adhesive and pile fabric -- as contrasted to
use of only two components -- core and pile fabric, (b)
substantial scrap loss due to the need to use preformed, hardened

cores of discrete length with consequent wastage at each end,
(c) high operating costs in addition to those mentioned earlier
if a pre-extruded and cooled core containing no residual heat is
reheated to assist in adhesive application, (d) substantial
5 inventory costs associated with stocking preformed cores, and
(e) limitation of the resultant roller cover products to organic
paint solvents. Controlling the optimum processing
characteristics of the adhesive and the specialized equipment for
its application can be particularly troublesome.

10 In the second method, exemplified by U.S. Patent 4,692,975,
pile fabric formed with a thermoplastic backing material is
applied directly to a compatible thermoplastic core blank, and
the use of adhesive with its associated cost and operating
drawbacks is thereby eliminated. The elimination of adhesive is
15 a distinct advantage because the thermoplastic materials commonly
used have good resistance to paint solvents in contrast to the
lesser resistance of components which have been used in the
adhesive systems, i.e., thermoplastic materials which can be
glued to generally have poor paint solvent resistance. Although
20 this system is a distinct advantage over adhesive type systems,
optimum results are not always achieved due to the discontinuous
nature of the process. For example, in this system, the
thermoplastic core blank is used in a pre-formed, hardened
condition of a discrete, maximum length. As a result, some
25 scrapage is inevitable in that both ends of the core blank,
after being wrapped with the pile fabric, must be cut off to
provide a functionally operative product, thus wasting both
portions of the core and the pile fabric resulting from the
scrapped end or ends of the otherwise completely formed product.
30 Further, since the core blank must be heated from room
temperature or other cold condition prior to application of the
pile fabric in order to ensure a good bond between the core and

fabric, the energy requirements are still substantial since the core blank has no residual heat.

Although proposals have been made for placing the pile fabric on a heated core, as for example in French Patent Publication 2,093,060, filed June 1, 1970 and published 1972 " Bulletin No. 4" in which pile fabric is placed on a hot, freshly extruded core, it is believed that no such system has gone into practical use, possibly because of the difficulties associated with controlling the shrinkage variation which inevitably occurs in the matching of what is essentially a through heated core blank and a cold (i.e., room temperature, for example) pile fabric

SUMMARY OF THE INVENTION

It is an object of the present invention to provide a paint roller which does not require adhesive to secure the core to the pile fabric and yet which can be manufactured without regard to numerous and continuous adjustments of the process to take into account variations in shrinkage characteristics of the materials used.

Another object is to provide a paint roller as above described which eliminates scrap or wastage except at the start up or close down of a production campaign whereby scrap is, for all practical purposes, eliminated.

Yet a further object is to provide a simple processing sequence and a manufacturing apparatus for such rollers which is of minimum complexity as contrasted to those proposed by the prior art.

These and other objects are obtained by continuously forming a tubular plastic core, preferably by laying up a two ply wrap over a mandrel with surface heating only of the contacting ply surfaces to form a continuous, endless, unitary thermoplastic core structure, cooling the inside and outside surface of the core structure to a final or near final internal diameter dimension, and, following contracting of the internal core structure to a final desired diameter, heat bonding a compatible thermoplastic pile fabric to the external surface of the core structure, followed by separation of the continuously produced composite structure into final pieces suitable, if desired, for use or further processing.

10

In an embodiment of the invention, there is provided a paint roller including a tubular core, wherein the core is formed of thermoplastic material, and is formed from a multiplicity of spirally wound plies of the thermoplastic material. The multiplicity of plies comprises an outer ply which surrounds and is in continuous contact with an inner ply. Each of the plies extends parallel to one another. The plies are fused to one another in the absence of adhesive. The core is of a generally unitary construction and has a radially innermost portion which is oriented in a given direction and a radially outermost portion which overlaps the innermost portion and is oriented in generally the same direction. The core is composed of polypropylene. A fabric cover overlies the multi-ply core. The fabric cover is heat fused to the underlying multi-ply core in the absence of adhesive.

In another embodiment of the invention there is provided a paint roller, including a tubular core, wherein the core is formed of thermoplastic material. The core is further formed from a multiplicity of plies of the thermoplastic material. The multiplicity of plies comprise an outer ply which surrounds and is in continuous contact with an inner ply. Each of the plies extends parallel to the other. The plies are fused to one another in the absence of adhesive. A fabric cover overlies the multi-ply core, and the fabric cover is heat fused to the underlying multi-ply core in the absence of adhesive.

In another embodiment of the invention there is provided a method of making a paint roller comprising the steps of forming a continuous tubular core

and subsequently forming a fabric cover on the continuous tubular core. The continuous tubular core is formed by heating and wrapping strip core material around a former having internal cooling means and means for accommodating radial inward shrinkage of the strip core material while continuously advancing and cooling the outer surface of the thus formed continuous tubular core in a downstream direction. Heat is applied to the exterior surface of the thus formed continuous tubular core, whilst the continuous tubular core is being advanced towards a discharge location. The fabric cover is formed on the continuous tubular core by wrapping strip fabric material around the heated surface of the continuous tubular core while the continuous tubular core is being advanced in the downstream direction whereby a continuous paint roller structure is formed.

In another embodiment of the invention there is provided an apparatus for forming paint rollers. The apparatus includes: means for forming a continuous tubular core from multiple layers of strip stock applied in a wrap within a wrap relationship; means for heating the surfaces of the wraps which overlie one another so that the surfaces are at an elevated temperature at the time the surfaces contact one another; means for simultaneously cooling the surfaces of the wraps which are not in contact with one another; means for moving the continuous tubular core in a downstream direction; means for accommodating radial inward shrinkage of the continuous tubular core as it moves in a downstream direction; means for forming a fabric cover on the continuous tubular core structure as the core structure moves in a downstream direction, whereby a continuous paint roller blank is formed; and means for severing discrete portions of the paint roller blank as the blank continuously moves in a downstream direction.

In another embodiment of the invention there is provided a paint roller including a tubular core formed from a multiplicity of specially wound strips of thermoplastic material. The inner and outer surfaces of an overlapping and underlying ply are heat fused to one another where they come in surface contact with one another. A fabric cover overlaps the multi-ply core. The fabric cover is heat fused to the outermost hot surface of the outermost ply.

4b

BRIEF DESCRIPTION OF THE DRAWINGS

The invention is illustrated more or less diagrammatically in the accompanying drawing wherein:

5 Figure 1 is a schematic side view of the system of this invention for continuously producing paint rollers without adhesives;

 Figure 2 is a schematic top view of the system of Figure 1;

 Figure 3 is an illustrative section through the mandrel after the two core plies have been layed up against one another but before fusion has gone to
10 completion; and

 Figure 4 is a section through the mandrel and the paint roller after the pile fabric has been layed up against the core structure but before the continuous, at that point, paint roller blank has cleared the end of the mandrel prior to severance.

15

DETAILED DESCRIPTION OF THE INVENTION

Like reference numerals will be used to refer to like parts from Figure to Figure in the drawing.

20

Referring first to Figure 1 the system for continuously producing paint rollers is indicated generally at 10. The system includes a former, here a circular mandrel 11, which, in this instance, is fixed. The mandrel is solid except for an internal cooling system indicated generally at 12. The cooling system includes a cooling fluid inlet conduit 13 which connects to a header block 14 from one side of which the internal cooling system 15 of the mandrel extends leftwardly as viewed in Figure 1. The internal cooling system includes an inlet line 16 and a return line 17, the end portion of the system being indicated at 18. In this instance, the inlet line 16 and return line 17 are simply parallel passages formed within the solid mandrel 11 and connected by a bend 19 which forms in effect the end portion of the internal cooling system. The return end of return line 17 connects to the cooling system header block 14 and elevated temperature cooling fluid leaves the system through discharge or take away line 20 at the right side of Figure 1. The end of the mandrel is indicated at 21.

A pair of strips of thermoplastic material are indicated at 23, 24, the strips, or plies, being wrapped around mandrel 11 one above the other, all as best seen in Figure 2. The underside of each ply is heated by heating means 25, 26 so that upon contacting engagement of the plies, the heated surfaces contact one another and bonding of one ply to another then begins. In the illustrated embodiment the plies are formed from general purpose polypropylene of approximately .02 inches thickness and about 2-3/4 inches width. Due to the greater internal diameter of the top ply 23, its width is preferably slightly greater than the width of the bottom ply, as for example on the order of about 1%, although the exact amount of increased width is determined by the thickness of the plies and the angle of feed to the mandrel.

as well as the inherent requirements of each installation to produce a smooth surface, all of which is determinable by adjustments as will be apparent to those skilled in the art. It should be understood that though a general purpose polypropylene has been described, any suitable thermoplastic material may be used so long as it results in a strong bond, upon application of heat, with itself, and is compatible with later applied pile fabric in the sense that a firm bond may be formed between the core structure and the pile fabric backing.

Since the plies are composed of thermoplastic materials to which heat has been applied prior to contact with one another and with the cooled mandrel, the plies will shrink as they are cooled by the mandrel and individual wraps will fuse tightly against one another. It is believed that recognition of this fact and accommodation of the resultant change in physical dimension that follows is one of the factors which sets this invention apart from the prior art. In this instance this change in physical dimension is accommodated for by varying the size and contour of the mandrel 11. Thus, in a first section, indicated generally at 28, of the mandrel, the outside dimension of the mandrel is preferably of a constant diameter. In a second section, indicated generally at 29, the outside diameter generally tapers to a smaller diameter in the left direction, and in a third section indicated generally at 30, the diameter along this section is the smallest diameter reached at the end of the tapered section 29. Since the cooling system 12 operates continuously, the hot, dimensionally expanded plies 23, 24 will be continuously subjected to the cooling effect and thus continually contracting in physical dimension.

A helix belt drive is indicated at 32 for moving the multi-ply core structure, initially, and the composite core-fabric structure, eventually, to the left until the process of formation is complete. The belt drive may be the well known Ford drive system which includes a pair of upright cylinders 33, 34, and an endless drive belt 35, at least one of the cylinders being a drive cylinder. A pair of hold down rollers 36, 37 cause the drive belt 35 to wrap at least 360 degrees around the mandrels so that adequate frictional engagement between the drive belt and the core structure to ensure rotation of the core, and the core-fabric structure, without slippage is achieved whereby a positive, easily controllable drive action is obtained. Thus, the speed of the entire process, including pulling of the strip materials from their sources, can be controlled by controlling the belt drive system.

As the now multi-ply core structure 27 moves to the left as viewed in Figure 1 under the driving influence of the belt drive 32, its external surface is subjected to the cooling effect of an external cooling means 40. In a preferred embodiment the specific cooling means 40 consisted of multiple water sprinklers feeding directly onto the core. The resultant rapid cooling creates a rather quick shrinkage effect thereby binding the core structure on the mandrel 11. However, the aforementioned taper in the second section 29 of the mandrel prevents the binding of the core structure to the mandrel to such a degree to interfere in operation. Cooling of the surface of the multi-ply core structure at this point also enables the belt drive to operate without overheating. The result is that a smooth surfaced, substantially stress free core structure leaves the left end 21 of the mandrel 11. As is thus apparent, adjustment, and proper operation, of the cooling system within the limits of operation fixed by the degree of mandrel taper and the temperature of the

core structure entering the cooling means all influence the efficient operation of the system. In one embodiment a mandrel which was approximately 1.5 inches in outside diameter at the right end as viewed in Figure 1 was gradually reduced in diameter by about 1% over a distance of approximately a yard.

The bonding or fusion of the pile fabric to the core structure commences after the core structure leaves the belt drive system 32. Specifically, surface heating means 41, 42 put heat into the exposed surface of the core structure just prior to application of the pile fabric to the core structure. A pair of gas ribbon burners have been used for the heating means 41, 42, the angle of the burner flames being adjusted to get optimum heating effect. The spacing of the burners from the core structure will, of course, vary, but in one embodiment a spacing of about 1/2" was found acceptable. It is not necessary or intended that burners 41, 42 heat the core blank completely through. All that is intended is that the core blank is heated to a degree sufficient to ensure good bonding with the subsequently applied fabric. In fact, through heating is undesirable.

The pile fabric is applied to the core structure in strip form as indicated at 44. Since the underside of the fabric strip is compatible with the heated exterior surface of the core structure, a bond between the fabric and core structure will form very quickly with the result that a unitary structure is formed. Since the bonding of the hot core structure to the room temperature fabric strip consumes energy, the joint between the two will cool and partially or fully solidify very quickly. In any event, the strength of the joint so formed will be quite capable of withstanding later downstream handling stresses.

After the composite core - fabric structure becomes self supporting and passes the end 21 of the mandrel, cut off means operate to sever what has theretofore been a continuously produced structure into discrete units. In this instance the cut off means is a travelling cut-off saw 46 which moves (a) in the direction of downstream progression of the composite structure, indicated by the arrow 47 in Figure 2, and (b) in a direction perpendicular to the direction of downstream progression; see arrow 48 in Figure 1 which indicates severing movement in directions perpendicular to the axis of mandrel 11.

The right end of a paint roller 50 is indicated generally at the left of each of Figures 1 and 2. Following severance, as by the cut-off saw 46, the now-formed paint roller may be packaged preparatory for sale, or further processed, as by end edge trimming which is dictated by commercial and end use considerations.

Figure 3 represents the condition of the two plies 23 and 24 after they have been layed up, but before the heat energy in the abutting surfaces have completed the fusion/bonding of one ply to another.

By contrast, in Figure 4 the fusion/bonding process has, at this later stage, gone to completion and, in all probability, the individual plies are so integrally bound to one another that no definite line of demarcation between the two plies can be seen. Further, at this stage in the process the pile fabric 44 has been similarly bonded to the now-unitary core and so again a sharp line of demarcation between the core and the pile fabric will not generally be discernable.

From the foregoing exemplary description it will be seen that a paint roller having a core non-adhesively bonded to a surface fabric is produced in a continuous process. It should be noted that by the use of a conventional festoon feeding assembly the supply of plies 23, 24 and fabric 44 can be endless since the ends of such materials can be joined to form continuous ribbons. As a result, and depending on the quality of the joints in the core plies and pile fabric, the system can operate without stopping for so long as raw materials and power are presented to it. Further, the core has the strength inherent in overlaid structures since the plies are oriented in parallelism with one another.

Although a preferred embodiment of the invention has been illustrated and described, it will at once be apparent to those skilled in the art that modifications may be made within the spirit and scope of the invention. Accordingly, it is intended that the invention not be limited by the foregoing exemplary description but solely by the hereafter appended claims when interpreted in light of the relevant prior art.

We Claim:

1. A paint roller, said paint roller including a tubular core,
said core being formed of thermoplastic material,
said core further being formed from a multiplicity of spirally wound
plies of said thermoplastic material,
said multiplicity of plies comprising an outer ply surrounding and in
continuous contact with an inner ply,
each of said plies extending parallel to one another,
said plies being fused to one another in the absence of adhesive,
said core being of a unitary construction having a radially innermost
portion oriented in a given direction and a radially outermost portion which overlaps
the innermost portion and is oriented in the same direction,
said core being composed of polypropylene, and a fabric cover overlying
said multi-ply core,
said fabric cover being heat fused to the underlying multi-ply core in the
absence of adhesive.
2. A paint roller, said paint roller including a tubular core,
said core being formed of thermoplastic material,
said core further being formed from a multiplicity of plies of said
thermoplastic material,
said multiplicity of plies comprising an outer ply surrounding and in
continuous contact with an inner ply,
each of said plies extending parallel to one another,
said plies being fused to one another in the absence of adhesive,
said core being composed of polypropylene, and a fabric cover overlying
said multi-ply core,
said fabric cover being heat fused to the underlying multi-ply core in the
absence of adhesive.
3. A paint roller, said paint roller including a tubular core,
said core being formed of thermoplastic material,

said core further being formed from a multiplicity of plies of said thermoplastic material,

said multiplicity of plies comprising an outer ply surrounding and in continuous contact with an inner ply,

each of said plies extending parallel to one another,

said plies being fused to one another in the absence of adhesive, and

a fabric cover overlying said multi-ply core,

said fabric cover being heat fused to the underlying multi-ply core in the absence of adhesive.

4. The paint roller of claim 3 further characterized in that the fabric cover includes a fabric backing which carries a pile fabric, the fabric backing being composed of thermoplastic material.

5. In a method of making a paint roller, the steps of forming a continuous tubular core by heating and wrapping strip core material around a former having internal cooling means and means for accommodating radial inward shrinkage of said strip core material while continuously advancing and cooling the outer surface of the thus formed continuous tubular core in a downstream direction,

applying heat to the exterior surface of the thus formed continuous tubular core while said continuous tubular core is being advanced toward a discharge location, and

forming a fabric cover on the continuous tubular core by wrapping strip fabric material around the heated surface of the continuous tubular core while said continuous tubular core is being advanced in said downstream direction whereby a continuous paint roller structure is formed.

6. The method of claim 5 further characterized in that the continuous tubular core is formed from at least two strips of material which are ply wrapped around the former,

the radially outermost strip overlying the radially innermost strip by 1/3 to 2/3 of the strip width.

7. The method of claim 6 further characterized in that the radially outermost strip overlaps the radially innermost strip, and in that the radially outermost strip is oriented in the same direction as the radially innermost strip.

8. The method of claim 6 further characterized in that only the surfaces of the strips which form the continuous tubular core which contact one another are heated prior to contact to ensure heat fusion of the contacting surfaces to one another, and the opposite surfaces of the strips which form the continuous tubular core are simultaneously cooled.

9. The method of claim 6 further characterized in that lubricant is applied to the radially innermost side of the inner-most strip prior to its wrapping around the former.

10. The method of claim 8 further characterized in that the surface of the formed continuous tubular core is cooled to a temperature suitable for engagement with driving means, and, in that, thereafter, the outer surface of the surface cooled continuous tubular core is heated just prior to application of the fabric cover to the tubular core.

11. The method of claim 5 further characterized in that individual paint rollers are formed from the continuous paint roller structure by severance of a desired portion of said continuous paint roller structure while the paint roller structure is moving in the downstream direction.

12. The method of claim 11 further characterized in that the severance of the desired portion of the said continuous paint roller structure becomes self supporting.
13. The method of claim 5 further characterized in that the continuous tubular core is formed by wrapping a plurality of strips of core material around a former in the presence of sufficient heat to bond the strips to one another while continuously advancing the formed continuous tubular core in a downstream direction.
14. The method of claim 13 further characterized in that the strips traverse along a former surface of decreasing diameter.
15. The method of claim 13 further characterized by and including the steps of
cooling the innermost and outermost surfaces of the formed continuous tubular core structure (i) prior to application of heat to the formed continuous tubular core and (ii) subsequent to the formation of the continuous tubular core.
16. The method of claim 13 further characterized in that the continuous tubular core is formed from ribbons and continuously advanced in a downstream direction by frictional engagement of a belt drive with the continuous tubular core.
17. The method of claim 16 further characterized in that driving force is applied to the continuous tubular core subsequent to both the formation of the continuous tubular core and the cooling of the surface of the formed continuous core but prior to application of surface heat to the formed continuous tubular core.

18. Apparatus for forming paint rollers, said apparatus including
- means for forming a continuous tubular core from multiple layers of strip stock applied in a wrap within a wrap relationship,
 - means for heating those surfaces of said wraps which overlie one another so that said surfaces are at an elevated temperature at the time said surfaces contact one another,
 - means for simultaneously cooling the surfaces of said wraps which are not in contact with one another,
 - means for moving said continuous tubular core in a downstream direction,
 - means for accommodating radial inward shrinkage of said continuous tubular core as it moves in a downstream direction,
 - means for forming a fabric cover on said continuous tubular core structure as said core structure moves in a downstream direction whereby a continuous paint roller blank is formed, and
 - means for severing discrete portions of said paint roller blank as said blank continuously moves in a downstream direction.

19. The apparatus of claim 18 further characterized
- in that the means for forming a continuous tubular core from multiple layers of strip stock is a mandrel about which the strip stock is wrapped as it is moved in a downstream direction by said moving means, and
 - in that the means for accommodating radial inward shrinkage of said continuous tubular core as it moves in a downstream direction is a gradual decrease in diameter of the mandrel over a portion of its length sufficient to enable the continuous tubular core to reach its final, shrunk configuration.

20. The apparatus of claim 19 further characterized by and including
- first cooling means within the mandrel for cooling the continuous tubular core from the inside out, and

second cooling means located immediately downstream of the location where the multiple layers of strip stock are applied to one another for bringing the temperature of the multi-layer strip stock to a level compatible with application of a belt drive associated with the moving means.

21. A paint roller, said paint roller including
a tubular core,
said core being formed of thermoplastic material,
said core further being formed from a multiplicity of specially wound strips of thermoplastic material
the inner and outer surfaces of an overlapping and an underlying ply where they come in surface contact with one another being heat fused to one another,
a fabric cover overlapping said multi-ply core,
said fabric cover being heat fused to the outermost hot surface of the outermost ply.
22. The paint roller of Claim 1 further characterized in that
the outermost, exposed exterior surface of the fabric cover is a pile fabric.
23. The paint roller of claim 2 further characterized in that the fabric cover is heat fused over the entire surface area of the core whereby adhesives are excluded.
24. The paint roller of claim 3 further characterized in that the core is of a unitary construction having a radially innermost portion oriented in a given direction and a radially outermost portion which overlaps the innermost portion and is oriented in generally the same direction.
25. The paint roller of claim 4 further characterized in that the fabric cover includes a fabric backing which carries the pile fabric, the fabric backing being composed of thermoplastic material.

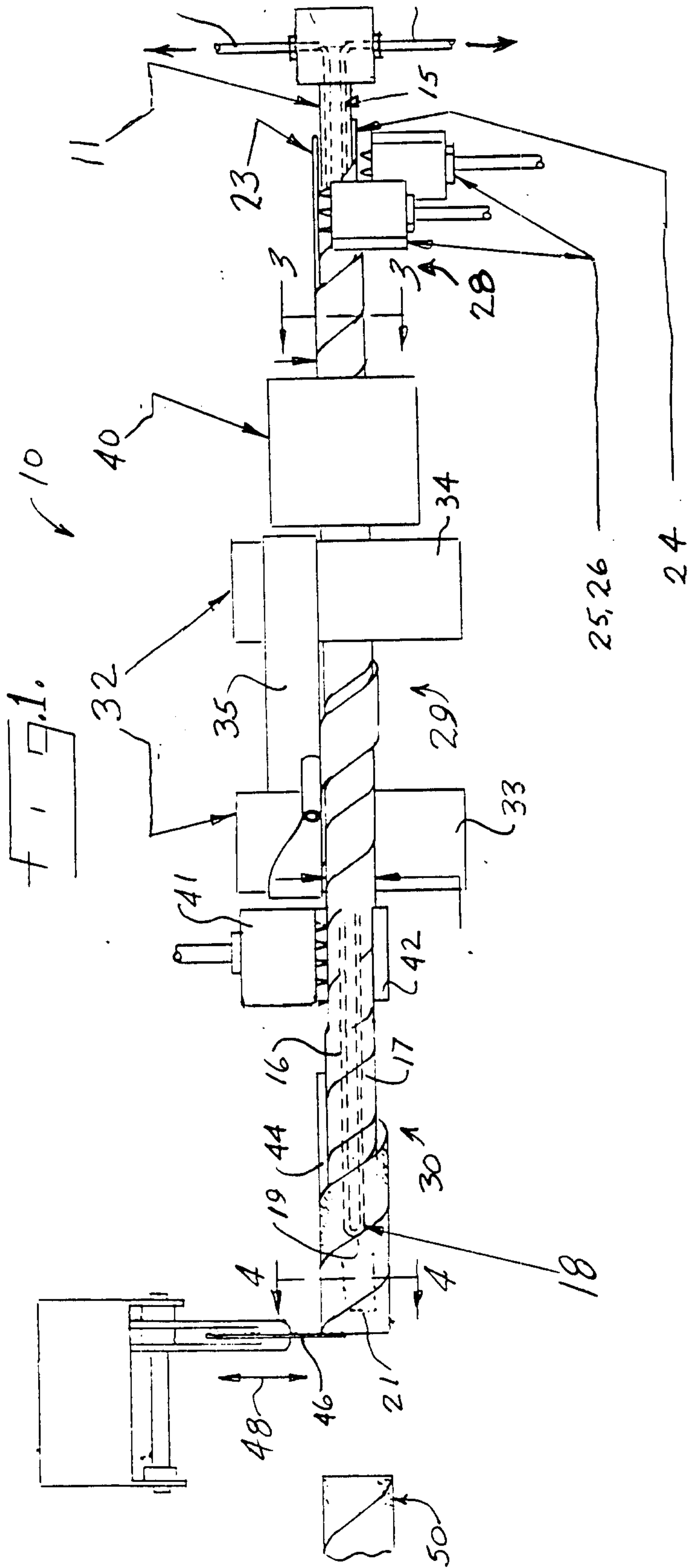
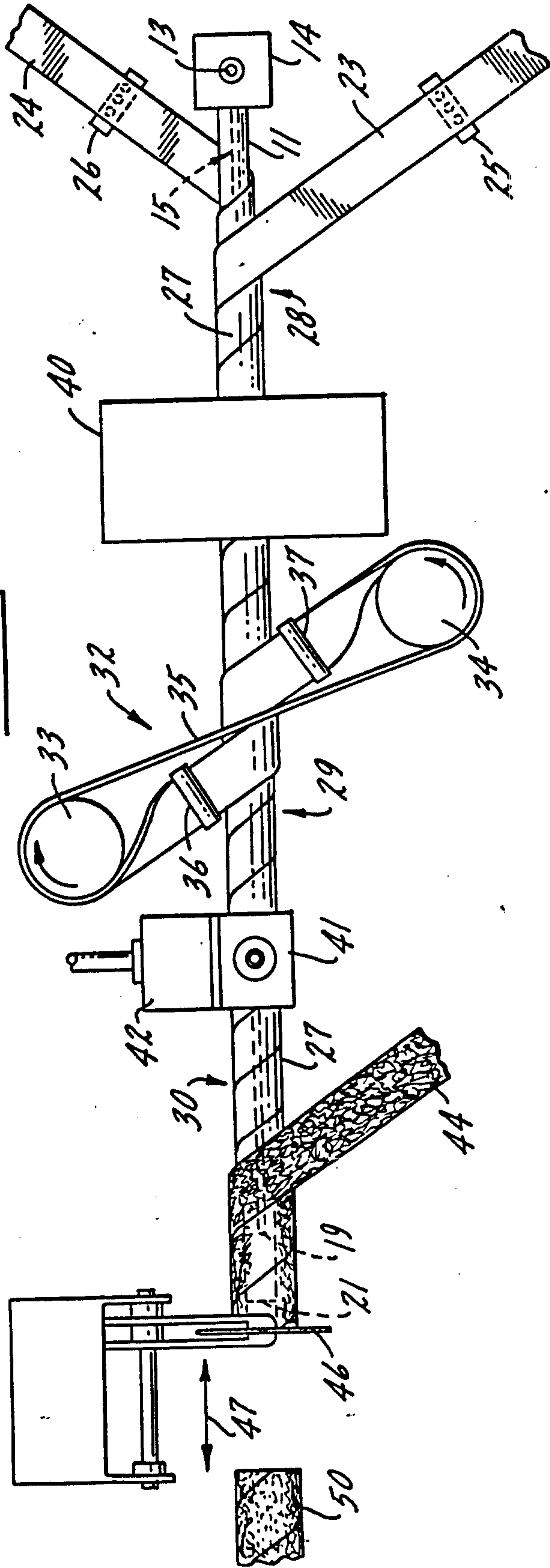

FIG. 2.



A

FIG. 4.

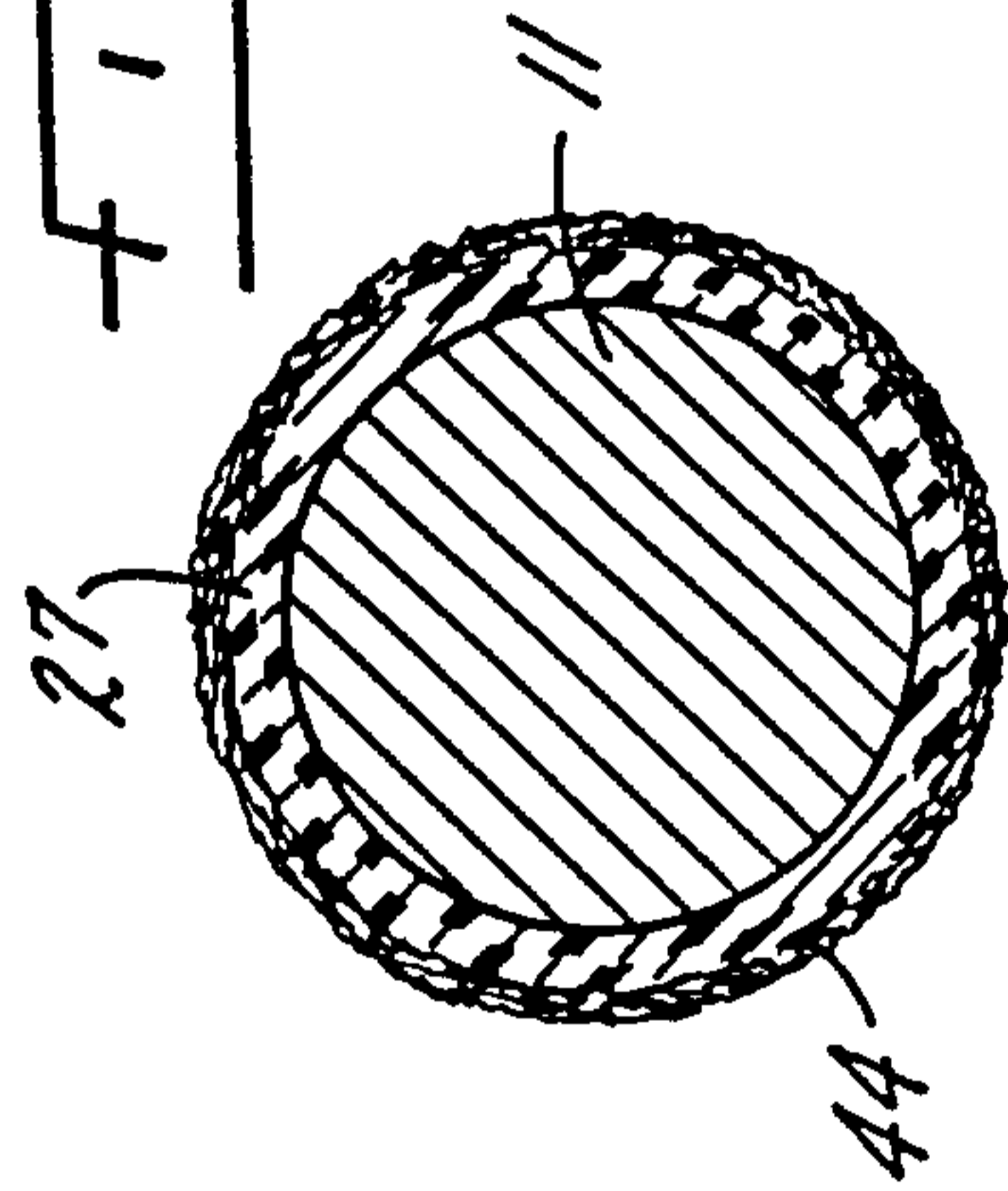

FIG. 3.

