



(11) (21) (C) **2,179,414**
(86) 1995/03/07
(87) 1995/09/21
(45) 2000/05/02

(72) Brannan, Jeffrey A., US
(72) Pham, Tuyen Van, US
(72) Mason, Thomas S., US
(72) Drummond, Jay Paul, US
(72) Hill, Jeffrey A., US
(72) Bruss, Paul T., US
(72) Hammer, Mark, US
(72) Rowe, Jim, US
(72) WALSON, DAVE, US
(72) BRICE, ROBERT, US
(73) INTERBOLD, US

(51) Int.Cl.⁶ B41J 15/04, B41J 33/54, B41J 32/00

(30) 1994/03/15 (08/213,411) US

(54) **IMPRIMANTE POUR DISTRIBUTEUR AUTOMATIQUE DE BILLETS**

(54) **PRINTER MECHANISM FOR AUTOMATED TELLER MACHINE**

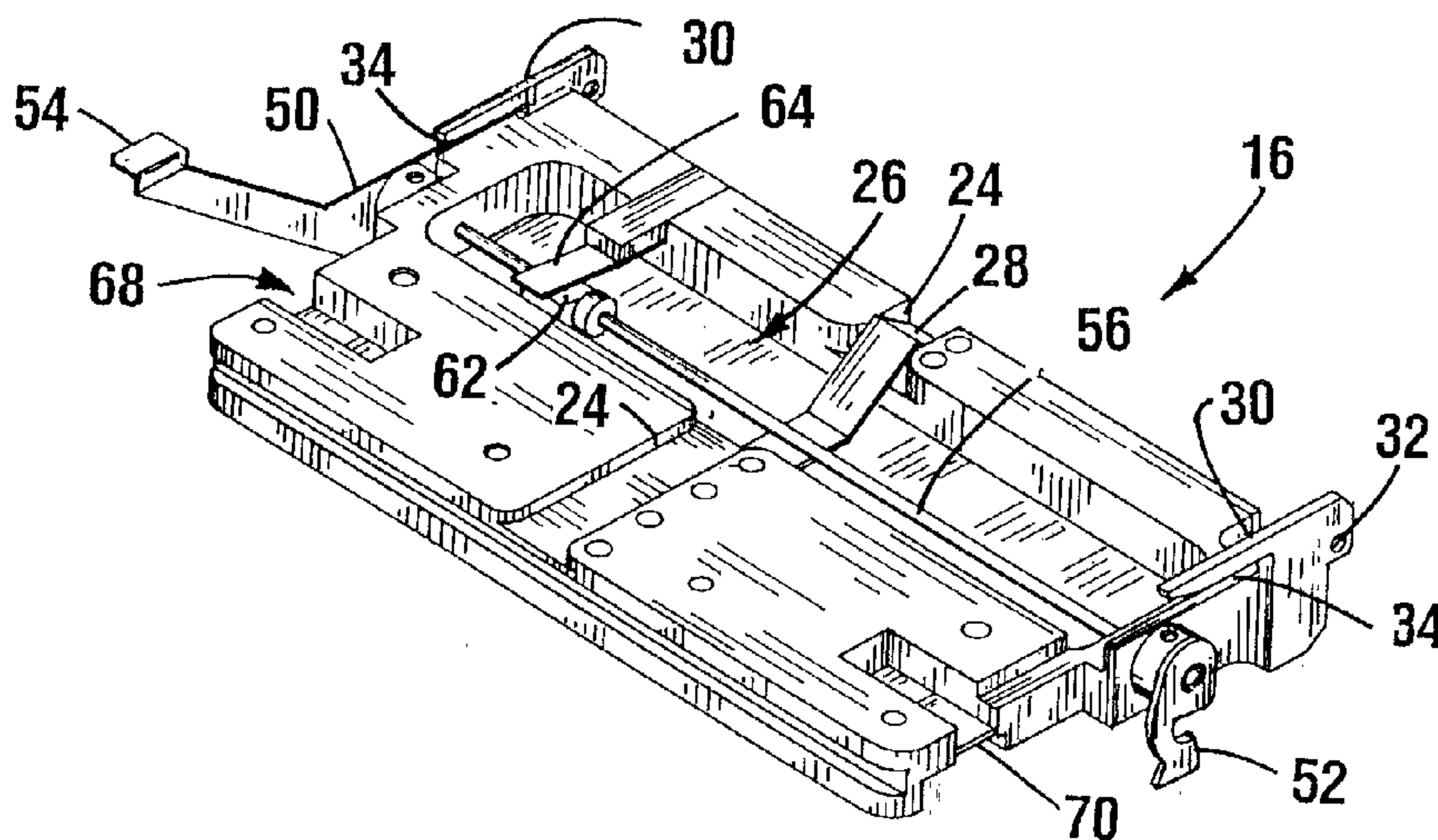

(57) Imprimante de bordereaux pour distributeur automatique de billets comportant une plaque supérieure (16) montée pivotante sur deux parois latérales (12) espacées et supportant une cartouche de ruban encreur (18) présentant deux protubérances dirigées (38) vers le

(57) A statement printer of an automated teller machine includes a top plate (16) pivotally mounted on a pair of spaced side walls (12). The top plate supports a ribbon cartridge (18) thereon. The cartridge includes a pair of downward extending projections (38) which are





(11) (21) (C) **2,179,414**
(86) 1995/03/07
(87) 1995/09/21
(45) 2000/05/02

bas et venant s'insérer dans un évidement longitudinal (24) pratiqué dans la plaque supérieure (16). Des encoches et les protubérances longitudinales (40) servent à encliqueter un ressort à lame (28) en vue du positionnement de la cartouche. La plaque supérieure présente également deux doigts (30) munis de fentes (34) destinées à recevoir les ailettes (36) s'étendant depuis les côtés de la cartouche. Le guidage s'opérant entre les protubérances s'étendant vers le bas et les ailettes sur la cartouche (36) et l'évidement longitudinal et les fentes pratiquées au sommet de la plaque, permet de positionner la cartouche sur cette dernière ou de l'enlever, ce qui facilite le changement de la cartouche dans l'espace confiné à l'intérieur d'un distributeur automatique de billets.

accepted in a longitudinally extending recess (24) in the top plate. Notches (40) and the longitudinally extending projections engage a leaf spring (28) to position the cartridge thereon. The top plate further includes a pair of finger projections (30) having slots (34) for accepting wing projections (36) that extend from the sides of the cartridge. The guided relationship between the downward extending projections and wing projections on the cartridge and the longitudinal recess and the slots on the top plate enable the cartridge to be guided into position on and off the top plate which facilitates changing the cartridge in the confined space inside an automated teller machine.





INTERNATIONAL APPLICATION PUBLISHED UNDER THE PATENT COOPERATION TREATY (PCT)

<p>(51) International Patent Classification ⁶ : B41J 15/04, 32/00, 33/54</p>	<p>A1</p>	<p>(11) International Publication Number: WO 95/25014 (43) International Publication Date: 21 September 1995 (21.09.95)</p>
---	-----------	--

(21) International Application Number: PCT/US95/02714
 (22) International Filing Date: 7 March 1995 (07.03.95)
 (30) Priority Data:
 08/213,411 15 March 1994 (15.03.94) US
 (71) Applicant: INTERBOLD [US/US]; 5995 Mayfair Road, North Canton, OH 44720 (US).
 (72) Inventors: BRANNAN, Jeffrey, A.; 5108 Beachview Circle NW, Massillon, OH 44647 (US). PHAM, Tuyen, Van; 4 Rolling Village Lane, Massillon, OH 44647 (US); MASON, Thomas, S.; 1205 Echo Street NE, Canton, OH 44721 (US). DRUMMOND, Jay, Paul; 3205 Roanoke Street NW, Massillon, OH 44646 (US). HILL, Jeffrey, A.; 6216 Chermont Street NW, Canton, OH 44718 (US). BRUSS, Paul, T.; 416 Peak Drive, Riverton, WY 82501 (US). HAMMER, Mark; 301 Elizabeth, Riverton, WY 82501 (US). ROWE, Jim; 607 Glacier Circle, Riverton, WY 82501 (US).
 (74) Agent: JOCKE, Ralph, E.; 231 South Broadway, Medina, OH 44256 (US).

(81) Designated States: AM, AT, AU, BB, BG, BR, BY, CA, CH, CN, CZ, DE, DK, EE, ES, FI, GB, GE, HU, JP, KE, KG, KP, KR, KZ, LK, LR, LT, LU, LV, MD, MG, MN, MW, MX, NL, NO, NZ, PL, PT, RO, RU, SD, SE, SG, SI, SK, TJ, TT, UA, UG, UZ, VN, European patent (AT, BE, CH, DE, DK, ES, FR, GB, GR, IE, IT, LU, MC, NL, PT, SE), OAPI patent (BF, BJ, CF, CG, CI, CM, GA, GN, ML, MR, NE, SN, TD, TG), ARIPO patent (KE, MW, SD, SZ, UG).

Published **2179414**
 With international search report.

(54) Title: PRINTER MECHANISM FOR AUTOMATED TELLER MACHINE

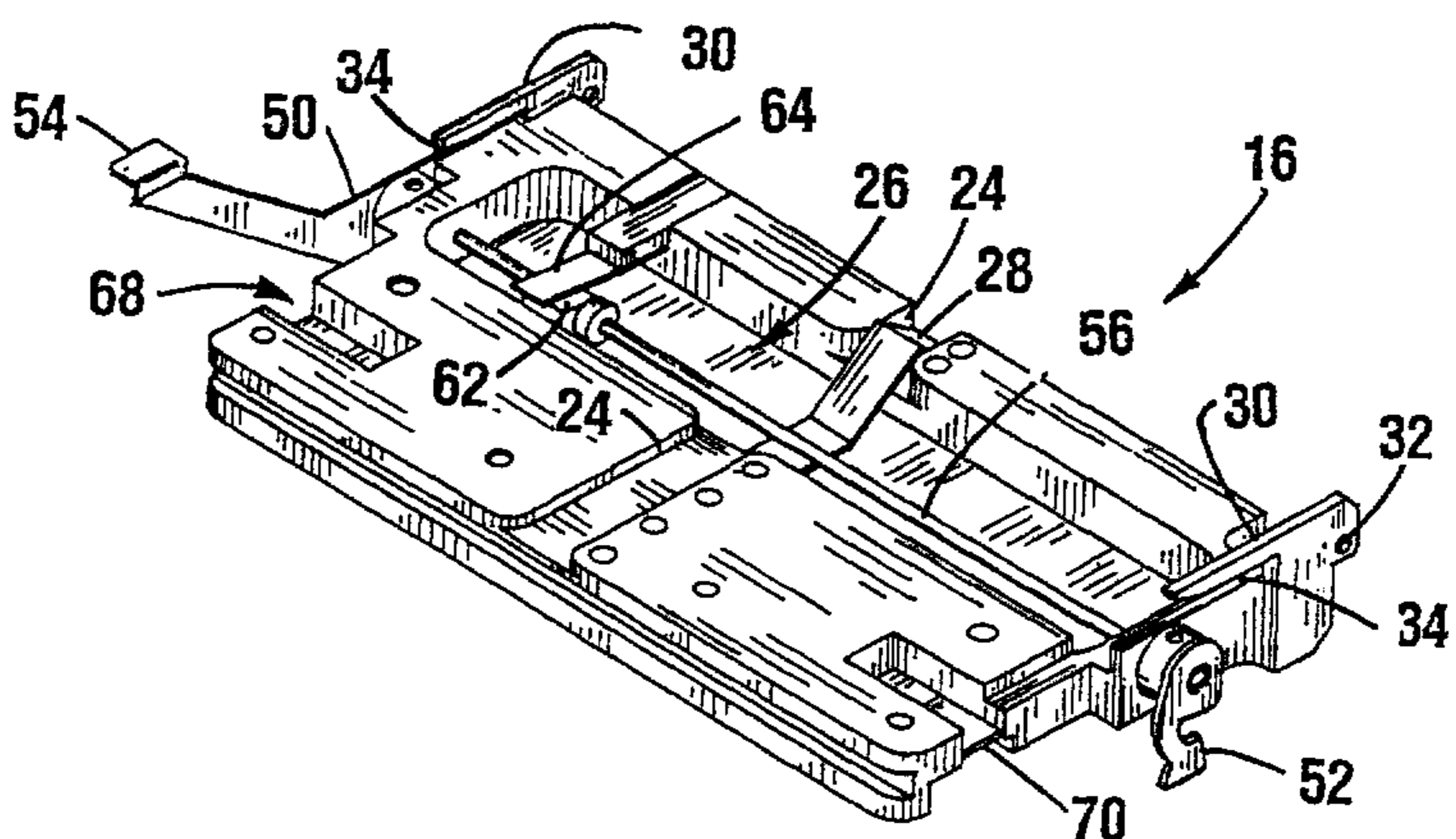

(57) Abstract

A statement printer of an automated teller machine includes a top plate (16) pivotally mounted on a pair of spaced side walls (12). The top plate supports a ribbon cartridge (18) thereon. The cartridge includes a pair of downward extending projections (38) which are accepted in a longitudinally extending recess (24) in the top plate. Notches (40) and the longitudinally extending projections engage a leaf spring (28) to position the cartridge thereon. The top plate further includes a pair of finger projections (30) having slots (34) for accepting wing projections (36) that extend from the sides of the cartridge. The guided relationship between the downward extending projections and wing projections on the cartridge and the longitudinal recess and the slots on the top plate enable the cartridge to be guided into position on and off the top plate which facilitates changing the cartridge in the confined space inside an automated teller machine.

DESCRIPTION

Printer Mechanism for Automated Teller Machine

TECHNICAL FIELD

5 This invention relates to banking devices and particularly to automated teller machines. Specifically this invention relates to a printer mechanism for use in an automated teller machine that can be used to print customer statements, checking account statements, vouchers, scrip, and other documents.

BACKGROUND ART

10 Automated teller machines (ATM's) are known in the prior art. Banking customers may access their accounts using a magnetically encoded card. Generally the customer will insert their card into the ATM which will correlate the identifying information encoded on the card with a personal identification number provided by the customer. This verifies the customer's identity to the computer system which operates the machine. Thereafter the customer may use
15 the ATM to conduct banking transactions as well as to check the status of various accounts that they have with the financial institution. When all the transactions and inquiries are completed, the customer will receive his card back from the ATM along with one or more receipts documenting the transactions performed.

20 As more people conduct their banking transactions electronically using ATM's, there is a need to provide more information concerning the status of their accounts. Customers often want to know, for example, what checks have cleared and/or what other deductions and/or charges may have been applied against their accounts. Customers may also wish to obtain information about other services provided by the financial institution such as investments,
25 retirement accounts or the terms available for loans.

It is usually not possible to print much information on a receipt that is provided by an ATM. This is because such receipts are usually fairly small in

2179414

2

size and are much like a cash register tape. To provide all the information that customers want in a legible format, larger sheets are needed.

Given the space constraints within the interior of an automated teller machine, it has been difficult to obtain enough space to accommodate a printer that can print large sheets. Because ATM's must operate unattended for extended periods of time, a substantial quantity of paper is required. Large sheets of paper will consume valuable space within the automated teller machine and further complicate incorporating a suitable printing mechanism.

Other factors also present difficulties in attempting to use statement printers within an automated teller machine. Wide sheets of paper tend to pucker or become caught when fed into printers. This problem is complicated due to the confined space within an automated teller machine. As a result, properly threading the paper into a printer becomes a problem. A similar problem is the need to periodically change the ribbon cartridge on the printers. Due to the limited space and access, it is often difficult to properly align and secure a new print cartridge after the previous cartridge has been removed.

Other problems associated with large statement printers in automated teller machines involve the need to obtain the maximum useful life out of a printer cartridge and to compensate for the decrease in available ink as a printer cartridge is used. In addition, there is often no satisfactory means for monitoring when the paper supply which is being used by a statement printer has reached a point where a replenishment is required. This task is particularly complicated because paper is used at different rates, and because stacks of paper are not necessarily uniform. This makes it difficult to determine when replenishment of paper is required.

Another problem with statement printers in automated teller machines involves providing a reliable cutting mechanism for cutting the paper after the statement has been printed. While cutting mechanisms are available, their size and complexity often makes it impractical to use them within an automated teller machine.

Thus there exists a need to provide a statement printer within an automated teller machine that overcomes the deficiencies and problems which have existed in the prior art.

DISCLOSURE OF INVENTION

5 It is an object of the present invention to provide a statement printer that is capable of printing on large sheets and yet is sufficiently compact to be housed within an automated teller machine.

It is a further object of the present invention to provide a statement printer on which it is easy to change the print cartridge within the restricted space in the
10 interior of an automated teller machine.

It is a further object of the present invention to provide a statement printer which simplifies the loading of paper therein.

It is a further object of the present invention to provide a statement printer that reduces skewing, pucker and prevents folds from being pressed into the
15 paper.

It is a further object of the present invention to provide a statement printer that enables rapid and reliable cutting of wide statement sheets.

It is a further object of the present invention to provide a statement printer that may be operated for long periods without a need for service.

20 It is a further object of the present invention to provide a statement printer that provides a signal when the paper supply is low.

It is a further object of the present invention to provide a statement printer that maintains the printing quality despite the aging of the ribbon cartridge.

25 Further objects of the present invention will be made apparent in the following Best Mode for Carrying Out the Invention and the appended claims.

The foregoing objects are accomplished in the preferred embodiment of the invention by a statement printer having a housing. The housing includes a cartridge-supporting top plate that is pivotally mounted. The top plate includes a longitudinally extending channel having a leaf spring extending upwards near
30 a front portion thereof.

2179414

4

A print ribbon cartridge which is replaceably mounted on the top plate includes guides which extend downward in straddling relation of the top plate, so that the print ribbon extends transversely across the bottom of the plate. The print cartridge further includes a pair of spaced, longitudinally extending
5 projections which are accepted in the recess in the top plate in close fitting relation. The projections of the cartridge include a pair of transversely aligned notches wherein the leaf spring is accepted when the cartridge is in properly mounted position. The leaf spring holds the cartridge in the properly aligned location during use.

10 The cartridge further includes a pair of transversely extending wing projections which extend from opposed sides of the cartridge. The top plate includes a pair of spaced slots for accepting the wing projections therein. The slots serve to hold the cartridge against the top plate and counter the force of the leaf spring.

15 The cartridge of the present invention may be readily changed within the limited confines of an automated teller machine. The pivoting top plate of the statement printer is tilted upward by turning a release mechanism which disposes the ribbon of the cartridge from the impact area of the print head. The top plate
20 may be pivoted so that the plate extends to a near vertical position. A person may thereafter slide the cartridge off the top plate, providing sufficient initial force so as to disengage the leaf spring from the cut-outs in the spaced projections. Further upward movement of the cartridge disengages the wing projections from the slots and enables the cartridge to be removed as the ribbon is no longer in straddling relation of the top plate.

25 Thereafter a new cartridge may be installed by bringing a new cartridge adjacent the top plate such that the spaced projections are aligned in interfitting relation with the recess in the top plate. The new cartridge is slid downwardly and forwardly on the top plate such that the wing projections are accepted in the slots and the leaf spring engages the cut-outs in the spaced projections. As this
30 is done the cartridge is automatically positioned so that the guides straddle the top plate and the ribbon is positioned under the top plate for proper printing.

Once the new cartridge is installed, the top plate is returned to its original position adjacent to the print head of the device. The feed rollers of the printer are then operable to move the paper between the top plate and the print ribbon so that the statement information may be printed thereon.

5 The cooperating print cartridge and top plate enable easy alignment, installation and removal of the cartridge within the limited confines of the interior of an automated teller machine. The design enables an unskilled individual to install the cartridge by "feel" in situations where visibility is limited. Further, the pivoting character of the top plate enables movement to any one of a number of
10 rotational positions wherein the cartridge may be replaced by a person located either in front of or behind the printer. As a result, the statement printer may be readily installed in automated teller machines that are serviced either from the front or the rear.

BRIEF DESCRIPTION OF DRAWINGS

15 Figure 1 is an isometric view of the statement printer of the present invention shown with its top plate lifted and with its lower paper guide plate removed so as to expose the print head and cutting mechanism.

Figure 2 is an isometric view of the preferred embodiment of the print ribbon cartridge of the present invention.

20 Figure 3 is an isometric view of the top plate of the statement printer.

Figure 4 is an isometric view of the lower surface of the printer cartridge.

Figure 5 is a partial cross-sectional view of the top plate with the printer cartridge shown mounted thereon.

25 Figure 6 is a partial cross-sectional side view of the statement printer showing the major internal components thereof.

Figure 7 is a partial cross-sectional front view of the statement printer showing the drive mechanism for the print head.

Figure 8 is a plan view of the lower drive roll shaft of the statement printer.

Figure 9 is a side view of a drive roller on the lower drive roll shaft shown in Figure 8.

Figure 10 is a plan view of the upper drive roll shaft of the statement printer.

5 Figure 11 is a cross-sectional view of a drive roller taken along line 11-11 in Figure 10.

Figure 12 is a cross-sectional view of a drive roller taken along line 12-12 in Figure 10.

10 Figure 13 is a cross-sectional view of a drive roller taken along line 13-13 in Figure 10.

Figure 14 is a cross-sectional view of a drive roller taken along line 14-14 in Figure 10.

Figure 15 is a side view of the upper and lower drive rollers showing statement paper between the rollers having creases and puckers therein.

15 Figure 16 is a view similar to Figure 15 showing the paper after having moved a distance through the rollers.

Figure 17 is a view similar to Figure 16 showing the paper after it has undergone further movement.

20 Figure 18 is a view similar to Figure 17 showing the paper after the rollers have undergone further movement and showing the final orientation of the paper without creases or puckers.

Figure 19 is a top view of the print head and cutter mechanism of the statement printer.

25 Figure 20 is a back view of the print head shown in Figure 19 with the cutter wheel shown in a cutting position.

Figure 21 is a top view of the print head and cutting wheel of the statement printer of the present invention shown in the cutting position.

Figure 22 is a back view of the print head and cutter shown in Figure 21.

30 Figure 23 is a top view of the print head and cutter mechanism shown with the cutter in a retracted position.

Figure 24 is a back view of the print head and cutter shown in Figure 23.

Figure 25 is a front view of the print head and cutter mechanism with the actuating lever shown in the cutting position.

Figure 26 is a front view of the print head and actuating lever shown in the retracted position.

5 Figure 27 is an isometric view of the actuating lever which serves to move the cutter mechanism.

Figure 28 is an exploded isometric view of the paper holding tray and low paper actuating mechanism of the present invention.

10 Figure 29 is a partial cross-sectional view demonstrating the operation of the low paper actuating mechanism of the present invention.

Figure 30 is a side view of the print head, guide block and cutter mechanism.

Figure 31 is a flow chart for the control of the print head.

Figure 32 is a graph of the print striking force used versus ribbon age.

15 BEST MODES FOR CARRYING OUT INVENTION

Referring now to the drawings and particularly to Figure 1, there is shown therein the preferred embodiment of the statement printer of the present invention, generally indicated 10. The device includes a housing including a pair of spaced side walls 12 which are connected to a tray portion generally indicated 14. The device further includes a top plate 16 which is pivotally mounted between the sidewalls. In Figure 1 top plate 16 is shown in its raised position and the bottom guide plate is removed to expose the other components of the machine. When the printer device is in operation the top plate is in the down and locked position and a lower guide plate is installed as shown in Figure 6.

25 The printer of the present invention includes a print ribbon cartridge 18 which is shown in greater detail in Figure 2. Cartridge 18 holds a print ribbon 20 which is impregnated with ink and which extends across the underside of the top plate when the print cartridge is mounted thereon. The print cartridge further includes a pair of downward extending ribbon guides 22 which guide the ribbon

20 and straddle the top plate 16 of the statement printer when the cartridge is mounted thereon.

As shown in Figure 3, top plate 16 includes a longitudinally extending recess 24 in the top thereof. Recess 24 extends on both sides of a laterally extending depressed area 26. A leaf spring 28 extends upwardly in the forward section of recess 24. The leaf spring includes a pointed angled top which is directed upwards.

The top plate further includes a pair of spaced finger projections 30. The finger projections include openings 32 at the front thereof which are sized for accepting a pin that enables the top plate to pivot with respect to the side walls 12. The finger projections 30 also define slots 34 which extend between the projections and the upper surface of the top plate.

Printer cartridge 18 includes on each side an extending wing projection 36. The wing projections 36 are sized for acceptance in slots 34. The wing projections 36 are positioned so that when the cartridge is mounted on the top plate, the finger projections 30 hold the cartridge 18 in close abutting relation to the top plate.

As shown in Figure 4, the lower side of cartridge 18 includes a pair of spaced downward extending projections 38. The downward extending projections extend longitudinally the length of the cartridge. Each includes a V-shaped notch 40 near the front of the cartridge.

When the print cartridge 18 is properly installed on the top plate, the pointed leaf spring 28 nests in the notches 40. In the preferred embodiment the notches are oriented so that the leaf spring is engaged when the wing projections on the cartridge are inserted to the full depth of the slots 34 formed by finger projections 30.

The construction of the print cartridge and top plate assures that the cartridge is in the proper position for printing documents. It further provides for an easy snap-in and snap-out fit. This enables the cartridge to be changed by a non-technician such as a bank teller. A fundamental advantage of this construction is that it is particularly well-suited for use within the confined space

inside an automated teller machine. The ability of the top plate 16 to pivot about the openings 32 allows the top plate to be moved out of the printing position through an arc of rotation to a position beyond the vertical. This enables a person to replace the cartridge while standing in a position either in front of or
5 in back of the statement printer.

A further advantage of this design is that the spaced projections 38 on the bottom of the cartridge may be guided by feel in the recess 24 on the back of the plate. As a result, the cartridge may be readily installed in the proper location without the need for the person changing the cartridge to see the exact position
10 of the cartridge. This is particularly important when the printer is mounted in an obscure location within the automated teller machine. The pointed leaf spring 28 also assures that the cartridge 18 is uniformly locked in position on the top plate and the construction enables the technician to feel locking action of the leaf spring against the cartridge, thus assuring proper installation.

As shown in Figure 4, the cartridge 18 includes a ribbon drive post 42
15 therein. The drive post has a chamfered, self-centering recess in the bottom thereof which accepts the top of the ribbon drive shaft 44 which is best shown in Figure 1. The drive post in the cartridge has a knob 46 connected at the top thereof which enables the manual take up of the ribbon.

To enable the ribbon drive shaft to disengage from the drive post of the
20 cartridge during a cartridge change, the top plate includes an opening 48 therethrough (see Figure 1). This enables the cartridge and the plate to move away from the ribbon drive shaft as the top plate 16 is raised. Of course, when the top plate is lowered, the ribbon drive shaft 44 extends upward through
25 opening 48 and engages the recess in the bottom of the ribbon drive post 42 of the cartridge. As a result, a person changing the ribbon cartridge in the statement printer need not be concerned about disengaging the drive mechanism for the ribbon, as it will automatically occur when the top plate is raised.

As shown in Figures 1 and 3, the top plate 16 includes a pair of latching
30 levers 50 and 52. Latching lever 52 includes a handle portion 54. The latching levers are connected by a shaft 56 that extends through the depressed area 26 in

the top of the top plate 16. The latching levers 50 and 52 each include recesses 58 that accept and latch on pins 60 that extend outward on the side walls 12 of the device. The engagement of pins 60 in the recesses serves to latch the top plate in position.

5 As shown in Figure 3, a cam 62 on shaft 56 engages a flat spring 64 which biases the latching levers 50 and 52 towards the engaging position. An advantage of this design is that the latching levers will tend to be in the position shown in Figures 1 and 3 unless manual force is applied to the handle portion 54. If the top plate should fall downward, the bottom faces 66 of the latching levers
10 will engage the pins and prevent the top plate from slamming against the print head, cutter or other components of the statement printer assembly.

The top plate further includes a pair of lateral recesses 68 which have flat springs 70 mounted therein. When the top plate is engaged to pins 60 by the latching levers, the flat springs 70 are biased upwardly by pins 72 that extend
15 inward from the side walls. The biasing action of the leaf springs 70 against the pins 72 provides for solid positioning of the top plate when it is latched in the down position.

The top plate further has a cutter bar 74 mounted thereon. The cutter bar is comprised of hardened metal and is positioned in a recess in the bottom side
20 of the top plate. The cutter bar cooperates with a cutter disk 76 to cut the paper that has been printed on by the statement printer as hereafter described.

As best shown in Figures 1 and 19 through 27, the cutter disk 76 has an outer tapered band 78 and a central band 80. As later explained, the tapered band is sized for being in close abutting relation with the trailing edge of the
25 cutter bar 76 to slice through the paper as the cutter disk moves across a sheet of paper.

Cutter disk 76 is mounted in a u-shaped arm 82. The u-shaped arm is mounted to a shaft 84. Shaft 84 extends through a print-head guide block 86. A spring-loaded button head 88 is mounted on shaft 84 at the opposed end of the
30 guide block from arm 82. The button head 88 is biased in the forward direction by a coil spring 90. An actuating lever 92 that is best shown in Figures 25

through 27 is mounted on shaft 84 between the button head 88 and the spring 90. Actuating lever 92 has a first arm 94, and a second arm 96 extending perpendicular to its first arm. The second arm 96 has a pin 98 extending forward therefrom as best shown in Figure 27. First arm 94 has a pin thereon that is
5 connected to a torsion spring 100. Torsion spring 100 has an opposed end that is connected to a spring-mounting pin on the guide block.

As best shown in Figures 25 and 26, actuating lever 92 operates to move shaft 84 (and consequently cutter disk 76) up and down. Guide block 86 is driven by a belt drive inside the housing, as later explained. The guide block is
10 mounted on an upper guide rod 102 and a lower guide bar 104 (see Figure 30). Lever stops 106 are in aligned arrangement with pin 98 on the actuating lever, and are positioned at the extremes of travel of the guide block as best shown in Figures 25 and 26. As the guide block 86 moves in the direction of arrow A as shown in Figure 26, the pin 98 on actuating lever 92 engages lever stop 106.
15 When this occurs, the actuating lever is rotated in a counter-clockwise direction as shown in Figures 25 and 26, so that the first arm 94 moves upward. The torsion spring 100 serves to bias the actuating lever and keep it in this position. When the guide block moves to the other extreme of its travel at the opposed end of the housing, pin 98 engages another lever stop. This opposite hand lever stop
20 when engaged moves the lever back to the position shown in Figure 26. The torsion spring then operates to bias the actuating lever to this position. The torsion spring 100 thereby operates to hold the actuating lever 92 in whichever one of the positions it is currently in.

As previously discussed, actuating lever 92 is connected through shaft 84
25 to the cutter disk 76. As a result, the rotation of shaft 84 by the actuating lever causes the cutter disk to move correspondingly up and down. Thus when the guide block reaches one extreme of its travel as shown in Figures 19 and 20, the cutter disk will move up. Thereafter when the guide block reaches the other extreme of its travel which is shown in Figures 21 through 24, the cutter will
30 move down.

In addition, the cutter mechanism of the present invention includes cam rollers 108 at the extremes of travel of the guide block. As shown in Figures 19, 21 and 23, the function of the cam rollers is to depress the button head against the force of coil spring 90. This causes the cutter disk to move outwardly. The
5 button head includes flattened cam engaging surfaces 89 thereon, to facilitate ease of engagement with the cam rollers and to facilitate the rotation of the button head (Figures 25-26). When the guide block moves so that the button head disengages from a cam roller, the cutter disk moves under the force of spring 90 inward towards the guide block. As a result, if the cutter disk is in the upward
10 position, the tapered band 78 will be positioned abuttingly against the edge of the cutter bar 74. This enables a clean, sharp cut of the paper.

At the other extreme of travel of the guide block, when the cutter disk is retracted downward, the engagement of the cam roller and the button head again moves the cutter disk away from the cutter bar and allows it to be readily retract-
15 ed. As a result, the cam rollers minimize the risk of possible impacts between the cutter disks and the edge of the cutter bar and further serve to minimize the friction associated with engaging and disengaging the cutting disk and the cutter bar. In addition, the central band 80 on the cutter disk rides on the bottom of the cutter bar and serves to provide precise positioning of the cutter disk.

20 In operation, when it is desired to cut the paper that is passing through the machine, guide block 86 is moved to the extreme of travel shown on the right side of the device in Figure 1. This causes the cutter disk to rise and engage the cutter bar. The guide block then moves transversely across the paper which the cutter disk cuts along the entire length of the cutter bar. When the guide block
25 reaches the other side of the housing, the cutter disk retracts downward.

As previously mentioned, the guide block 86 also has mounted thereon a print head 110. The print head includes a plurality of impact pins (not separately shown) which are positioned in an impact area 112. As best shown in Figure 1, the impact area 112 of the print head is positioned below ribbon 20 when the top
30 plate 16 is in the down position.

As best shown in Figures 6, 7, and 30, the print head is driven back and forth in the housing of the statement printer on upper guide rod 102 and lower guide bar 104. The guide block 86 which holds the print head is moved by a belt 114. Belt 114 is driven by a motor 116 which drives the belt through a pulley arrangement. In operation the motor controls movement of the guide block and thus selectively moves the print head back and forth as printing is accomplished on the paper.

When the statement is printed and the paper is advanced in the manner hereafter described, the motor moves the guide block 86 to the first extreme of travel to raise the cutter disk 76, moves it across the sheet, cutting the paper, until it reaches its other extreme of travel where the cutter retracts. The cut statement is then ready to be passed on to the next device, which in the preferred form of the invention is a statement presenter which stacks the statements and presents the stack to the ATM customer.

A further novel feature of the present invention is the ability of the invention to remove puckers and creases from the paper passing therethrough. The paper-moving invention includes a lower roll shaft 118 which is best shown in Figures 8 and 9. Lower roll shaft 118 has 4 round rubber rolls 120 mounted thereon. The rolls 120 are preferably rubber or other material that is suitable for providing good frictional engagement with the paper to be moved through the statement printer. The invention further includes an upper roll shaft 122 which, as shown in Figure 1, is preferably located above and adjacent to lower roll shaft 118.

As best shown in Figures 10 through 14, upper roll shaft 122 has 4 flat spot rolls 124, 125, 126 and 127 mounted thereon. As shown in Figures 11 through 14, the flat spot rolls each have a flat spot. The flat spot on each roll is angularly disposed from the flat spot on an adjacent roll. The flat spots are sized so that when a flat spot is directed towards an adjacent lower roll 120, the paper is enabled to move laterally in between. However, paper control is maintained by always providing contact with at least two drive rollers at all

times. During each rotation of upper roll shaft 122, each of the flat spots on the rollers passes the adjacent roll.

As shown in Figure 6, lower roll shaft 118 is driven by a motor 128. Motor 128 is a stepping motor which drives a toothed belt 129 which engages a pulley on the lower roll shaft. Motor 128 enables accurate control of the rotation of the lower roll shaft and the rolls 120 thereon. The upper roll shaft 122 has its rolls 124, 125, 126 and 127 generally in engagement with the rolls 120. As a result, the upper roll shaft rotates therewith.

The use of the flat spot rolls enables the smoothing of puckers and creases in the paper that is passed through the statement printer. It also avoids pressing folds into the paper as often occurs with other printers. This is best illustrated in Figures 15 through 18. As shown in Figure 15, the paper 130 between the rolls will sometimes have puckers or creases as shown between the outboard rolls in Figure 15. This is particularly common after the paper has first been fed into the rolls. This is more of a problem with wide paper, and is more common within an automated teller machine wherein there is limited room, and it is difficult to see and the paper is prone to misalignment.

As shown in Figures 16, 17 and 18, as each of the flat spots on the flat spot rolls approaches the face of the cooperating roll 120, the puckers and creases are enabled to smooth out because the paper 130 may move laterally. As a result, within a matter of a very few rotations the paper has reached a perfectly smooth and aligned condition as shown in Figure 18. Of course, the statement printer also has a paper lead-in tray 132 as shown in Figure 6 which includes upright guiding edges thereon to urge the paper to track straight and to help a technician who must initially feed the paper between the rolls of the statement printer.

In the preferred embodiment of the invention, the guide rolls are operated under control of a printer control which includes a processor. Each time the top plate 16 is lowered to a non-printing position, which indicates a paper jam or a cartridge change, the processor causes the rolls to drive the paper back and forth several inches. This removes puckers and creases in the paper and assures that

the paper extends above the ribbon 20. As shown in Figure 1, a switch 29 is used to sense when the top plate has been moved to the down position. Switch 29 also serves to verify that the top plate is properly latched before printing is commenced.

5 Another novel feature of the statement printer of the present invention is its ability to accommodate large stacks of paper. This enables the printer to operate unattended for a long period of time. However, any stack of paper will eventually be depleted and require replenishment.

10 The statement printer of the present invention includes a novel mechanism which enables the printer to provide a signal when the paper is low. As shown in Figure 28 the tray portion 14 of the device includes an outer tray 134 and a middle tray 136 which nests within the upright walls 138 of the outer tray. An inner tray 140 is positioned inside the middle tray 136. The inner tray 140 includes a pair of pivots 142 at the rear thereof. The pivots 142 suspend the rear of the inner tray slightly above the surface of the middle tray 136. As a result
15 the inner tray 140 is pivotally movable to a slight degree within the middle tray 136.

The inner tray further includes a tab 144 which extends laterally outward therefrom. A leaf spring 146 includes a yoke 148 which has a pin extending
20 therethrough (see Figure 29). The pin extending through yoke 148 extends through the wall of the middle tray 136 and engages the upright walls 138 of the outer tray. The mechanism further includes an overlying bracket 150 which has a slot 152 therein. The bracket 150 includes a downward-extending flange 154 which engages an upright wall 138 of the outer tray and is fixably mounted
25 thereto by conventional fastening means.

An adjusting slider 156 is mounted below bracket 150. Slider 156 includes a roller pin 158 which extends below leaf spring 146. Slider 156 further includes a threaded stud 160 which extends upward through slot 152 and is threadably engaged with a knob 162. As shown in Figure 29, leaf spring 146
30 engages the underside of tab 144. As a result, leaf spring 146 tends to bias the front of the inner tray 140 upward. Because stud 160 is selectively movable in

2179414

16

slot 152, the amount of biasing force exerted by leaf spring 146 on tab 144 is adjustable. This enables selective adjustment of the weight of the paper that can reside on inner tray 140 before tab 144 will rise upward in response to the biasing force.

5 An electrical switch 164 is positioned to actuate in response to the rising of tab 144 and to generate a signal. As a result when the weight of the paper on the inner tray 140 has decreased to a point where the biasing force of the leaf spring 146 overcomes the weight of the paper, switch 164 will send a signal which indicates that the amount of paper available for the statement printer is low
10 and needs to be replaced.

In the preferred form of the invention, bracket 150 adjacent to slot 152 is graduated to indicate the positions of knob 162 which correspond to the amount of paper remaining when the inner tray will rise and provide a signal. This enables accurate setting of when the low paper signal is given. In addition,
15 large amounts of paper may be placed on the inner tray 140 without causing any damage, as the movable front of the inner paper tray will not move any further than to engage the upper surface of middle tray 136. As a result, the statement printer of the invention provides a reliable and accurate indication of when the paper is low. This enables it to run unattended for long periods of time.

20 In alternative embodiments of the invention the middle tray may be eliminated. In such designs the inner tray is pivotally mounted directly in the outer tray.

As best shown in Figure 6, the path of paper 130 through the statement printer is through the lead-in tray 132 and between the rollers on the upper and
25 lower roll shafts 122 and 118 respectively. The paper then passes below the top plate 16 and above a lower guide plate 164 which extends above the guide block 86 and the print head 110 so as to support the paper. The guide plate 164 terminates rearwardly where the printer ribbon 20 passes under the top plate 16, and serves to direct the paper above the ribbon. The printer further includes a
30 support plate 166 as best shown in Figure 1 which is arcuate in cross section and extends between the side walls 12. The support plate holds the paper upward and

adjacent to the cutter bar 74. Support plate 166 is preferably coated with a non-stick, plastic material to facilitate free passage of the paper thereover.

5 In operation, the paper is moved through the statement printer by the action of the rolls 120 which are driven by motor 128. As the paper is advanced, the print head 110 is moved back and forth in the guide block and is operated under the printer control as directed by signals from a remote processor to print the characters on the advancing paper. The print head is operated under the printer control so as to correlate between the advance of the paper by rollers 120 and the movement of the print head 110 across the paper.

10 A further novel aspect of the present invention is that the computer processor which controls the operation of the print head functions to maintain print quality as the ribbon ages and ink is depleted. Cartridge 18 is such that the ribbon 22 may pass the print head many times during its useful life. The processor which controls the operation of the print head is programmed with information concerning the anticipated depletion of the ink from the ribbon with each pass of the ribbon over the print head and the printing of characters therewith. This information is used to modify the strike force of the pins of the print head 110. As a result, the life of the ribbon as well as the life of the print head is extended.

20 In operation, a central processor 170 either in the ATM or remote has stored in a non volatile memory 172 associated therewith a "strike force versus age" curve for ribbon cartridge 18 such as shown in Figure 32. The central processor sends signals representative of characters to be printed to the control module 174 which includes processor and circuitry which drives the printer. The control circuitry is adapted to run in either draft or letter quality modes in accordance with signals from the central processor. This enables the institution operating the ATM to vary the print quality for various types of documents. The signals which are presented to the printer control are generally presented as ASCII characters, however graphics may also be printed by signals presented in a bit mapped format.

25

30

The printer control 174 is initialized with a value for the striking force of the needles of the print head 110 based on an initialization signal from the central processor 170. The printer control module 174 then converts the signals into the striking signals for the needles, the signals for the movement of the head and for movement of the rolls 120 that move the paper. The control module 174 changes the pulse width of the electrical signals that drive the needles of the print head. As a result the "newer" the ribbon, the more ink that is present and the less the striking force required to attain the desired print quality. The reduced striking force is attained by lessening the pulse width of the signals that drive the needles.

Upon completion of printing a document the printer control totals the number of needle firings. This number is calculated by a counting routine 176 in the control module. The total is divided by a constant to produce an approximate number of "draft characters". This number is reported to the central processor 120 where it is added to the prior total number of draft characters printed for the ribbon. The total is then stored in the non-volatile memory 172 associated with the central processor.

At the start of the next transaction conducted through the ATM which requires the printer to operate, the central processor 170 reads the accumulated ribbon use data stored in memory 172. It then forwards the data to the printer control module 174 to adjust the pulse width of the signals that activate the needles of the print head 110. As the ribbon cartridge is used and the ink depleted, the strike force of the needles is increased to maintain the print quality.

The printer of the present invention also tracks the use of the ribbon and generates a signal warning of the depletion of the ribbon cartridge. This signal is generated by the central processor based on the amount of characters stored in the memory reaching a preset limit. When the ribbon is replaced the person who replaces the ribbon inputs a signal to the central processor to reset its memory and begin the process anew.

Because the needles of the print head do not strike with full force when the ribbon is new the ink is conserved on the ribbon. This increases the life of

the ribbon. Reducing the impact force during much of the print head's use also prolongs its life. This reduces the frequency of maintenance and reduces cost.

Thus the new statement printer of the present invention achieves the above-stated objectives, eliminates difficulties encountered in the use of prior devices and systems, solves problems and attains the desirable results described
5 herein.

In the foregoing description certain terms have been used for brevity, clarity and understanding, however, no unnecessary limitations are to be implied therefrom because such terms are for descriptive purposes and are intended to be
10 broadly construed. Moreover, the descriptions and illustrations given are by way of examples and the invention is not limited to the exact details shown and described.

Having described the features, discoveries and principles of the invention, the manner in which it is constructed and operated and the advantages and useful
15 results attained, the new and useful structures, devices, elements, arrangements, parts, combinations, systems, equipment, operations and relationships are set forth in the appended claims.

WE CLAIM:

1. A printer cartridge detachably mounted on a support plate of a printer, said support plate including a longitudinally extending recess and a resilient outward extending leaf spring, said cartridge comprising:
 - at least one longitudinally extending projection, said longitudinally extending projection acceptable in said recess in close fitting relation whereby said cartridge is aligned on said support plate;
 - at least one notch in said projection for accepting said resilient leaf spring therein when said cartridge is in an aligned condition.
2. The printer cartridge according to claim 1 wherein said cartridge comprises a pair of laterally extending wing projections extending from opposed sides of said cartridge, said wing projection acceptable in spaced longitudinally extending slots in said support plate.
3. The printer cartridge according to claim 1 wherein said cartridge comprises a first face surface, said first face surface in supporting relation with said support plate when said cartridge is mounted thereon, and wherein said longitudinally extending projection extends outward from said first face surface.
4. The printer cartridge according to claim 3 wherein said cartridge comprises a pair of spaced side walls extending transversely of said first face surface, and wherein said cartridge further comprises a pair of wing projections extending outward from each of said side walls.
5. The printer cartridge according to claim 4 wherein said first face surface is a generally planar surface and wherein said wing projections are generally aligned with and extend parallel to said first face surface.

6. The printer cartridge according to claim 5 wherein said longitudinally extending projection includes a tapered surface disposed longitudinally from said notch, and wherein said tapered surface is disposed on a first longitudinal side of said notch, said tapered surface extending in a direction away from said first face surface and toward said notch, whereby said tapered surface depresses said leaf spring prior to engagement in said notch as said cartridge is engageably mounted on said support plate.
7. The printer cartridge according to claim 4 wherein said cartridge comprises a pair of transversely spaced longitudinally extending projections, said spaced projections acceptable in interfitting relation to spaced walls bounding said recess of said support plate, whereby movement of said cartridge in the traverse direction on said support plate is minimized when said cartridge is mounted thereon.
8. The printer cartridge according to claim 4 wherein said recess of said support plate is bounded by spaced parallel extending recess surfaces, and wherein said cartridge comprises a pair of opposed projection wall surfaces, wherein said projection wall surfaces are acceptable in guided interfitting relation between said recess surfaces when said cartridge is mounted on said support plate.
9. The cartridge according to claim 4 wherein said cartridge includes a ribbon drive post, said ribbon drive post accessible through an opening in said first face surface.
10. The cartridge according to claim 4 and further comprising a pair of spaced ribbon guides extending from said cartridge, and wherein said support plate is acceptable between said ribbon guides.
11. A printer mechanism comprising:

a frame;

a top plate supported on said frame;

a printer cartridge;

longitudinally and transversely extending projections on one of said top plate or said printer cartridge, said other of said top plate or cartridge including recesses accepting said longitudinally and transversely extending projections therein in nested relation when said printer cartridge is mounted on said top plate.

12. The printer according to claim 11 wherein paper is movable on said printer adjacent said cartridge, and further comprising a plurality of aligned engaging pairs of paper feed rolls, said paper extending between each of the rolls of said pairs, and wherein at least one of said rolls in each said pair includes a circumferential flat spot, whereby said paper is not held between said roll pair when said flat spot is adjacent said paper.
13. The printer according to claim 12 wherein said flat spots on said rolls are angularly disposed from one another and wherein during movement of said paper, flat spots on adjacent roll pairs are not concurrently adjacent the paper.
14. The printer according to claim 12 further comprising a first roll shaft, said first roll shaft extending traverse to the direction of paper travel and wherein each of said rolls with a flat spot is mounted on said first roll shaft, wherein said flat spots are angularly disposed from one another, whereby at least one roll with a flat spot engages said paper and at least one roll with a flat spot does not engage said paper.
15. The printer according to claim 14 further comprising:

a second roll shaft, said second roll shaft extending parallel to said first roll shaft, and wherein a plurality of rolls are disposed on said second roll shaft adjacent said rolls with flat spots on said first roll shaft;

a stepper motor, said stepper motor operatively connected to said second roll shaft for rotation thereof, whereby said rolls move said paper when said second roll shaft is rotated.

16. The printer according to claim 15 further comprising control means, wherein said printer control means causes said stepper motor to rotate the second roll shaft several times in one direction and then rotates the second roll shaft several times in the opposite direction, whereby the paper is oscillated back and forth between the rolls.
17. The printer according to claim 16 further comprising top plate position sensing means, said position sensing means communicating a signal to said print control means when said top plate is moved to a nonprinting position, whereby said signal causes said print control means to initiate said paper oscillation.
18. The printer according to claim 11 wherein said top plate is rotatably mounted on said frame, and wherein said printer further comprises a latching lever in operative connection with said top plate, said latching lever engageable with said frame, and wherein said latching lever is engaged with said frame in an operative position of said top plate, and further comprising a spring biasing said top plate against an engaging force of said latching lever when said latching lever engages said frame.
19. The printer according to claim 18 and wherein said frame comprises a pin, said latching lever engageable with said pin when said top plate is in the operative position, and wherein said latching lever further comprises a face engageable with said pin wherein said face engages said pin in abutting relation to prevent movement of said top plate toward said operative position, and wherein said

printer further comprises a further spring biasing said face of said latching lever to a position wherein said face of said lever engages said pin, whereby said top plate is prevented from inadvertently moving to the operative position.

20. The printer according to claim 18 wherein said top plate comprises a transversely extending recess and wherein a leaf spring extends in said transversely extending recess, and wherein said leaf spring biases said top plate against a force of said latching lever holding said top plate in the operative position.
21. The printer according to claim 11 and further comprising a print means for printing on an adjacent paper, said print means mounted on a guide block movably mounted on said frame, and further comprising a cutter movably mounted on said guide block, and a lever operatively connected to said cutter, said printer further including lever stops at extremes of travel of said guide block on said frame, and wherein engagement of said lever with a first lever stop moves said cutter to a cutting position cutting said paper, and wherein engagement of said lever with a second lever stop moves said cutter to a noncutting position.
22. The printer according to claim 21 and further comprising a cutting edge, said paper extending between said guide block and said cutting edge, and wherein said cutter is connected to said lever by a shaft, said shaft movable both rotationally and longitudinally on said guide block, and wherein said printer includes first and second cam rollers adjacent said first and second lever stops respectively, and wherein said shaft is operatively engaged with said cam rollers upon engagement with said lever stops, whereby said cutter is disposed from said cutting edge prior to movement of said cutter adjacent to or away from said cutting edge.
23. The printer according to claim 22 and further comprising a cutter bar, and wherein said cutting edge is an edge of said cutter bar, and wherein said cutter

is a rotatable cutter, said rotatable cutter including a first circumferentially extending band and a second circumferentially extending band, and wherein when said cutter is in the cutting position said first circumferential band is engaged in rolling relation on said cutter bar and said second circumferential band is adjacent to said cutting edge.

24. The printer according to claim 22 wherein said shaft has a further lever arm in operative connection therewith, said further lever arm movable between first and second positions with movement of said cutter between cutting and non-cutting positions respectively, said printer further comprising a lever spring in operative connection with said further lever arm, and wherein said lever spring biases said further lever arm toward a then current position of said further lever arm.
25. The printer according to claim 11 and further comprising:
- a tray whereby a stack of paper is supportable on said tray;
 - a pivot rotationally mounting said tray on said frame;
 - a leaf spring having a first end and a second end, said first end of said leaf spring engaged with said frame and said second end of said leaf spring in operative engagement with said paper tray;
 - and a sensor sensing said tray moving responsive to depletion of said paper stack.
26. The printer according to claim 25 and further comprising a slider movably engageable between said frame and said leaf spring, wherein movement of said slider selectively changes the biasing force applied by said leaf spring on said paper tray.

26. The printer according to claim 25 and further comprising a slider movably engageable between said frame and said leaf spring, wherein movement of said slider selectively changes the biasing force applied by said leaf spring on said paper tray.
27. The printer according to claim 11 wherein said print cartridge is a ribbon cartridge and wherein said printer further comprises an impact print head having members striking a ribbon extending from said print cartridge, said printer further comprising a processor and a memory in operative connection with said print head wherein said processor is operative to count characters printed by said print head on said ribbon and to store the total number of characters printed in the memory, and wherein said printer is operative to modify a striking force of said print head against said ribbon responsive to the number stored in said memory.
28. The printer according to claim 27 wherein said processor provides a signal when the number of characters printed with said ribbon exceeds a limit.
29. The printer according to claim 27 and further comprising means for resetting said memory upon installation of a new print cartridge.
30. The printer according to claim 27 and further comprising a printer control module in operative connection with said processor and said print head, and wherein the number of impacts by said print head with said ribbon is divided by a constant to achieve a number of draft characters printed by said print head wherein said number of draft characters is stored in said memory.
31. The printer according to claim 27 wherein said printer control delivers signals to said print head and wherein a pulse width of the signals to said print head is modified responsive to the number of draft characters stored in the memory.

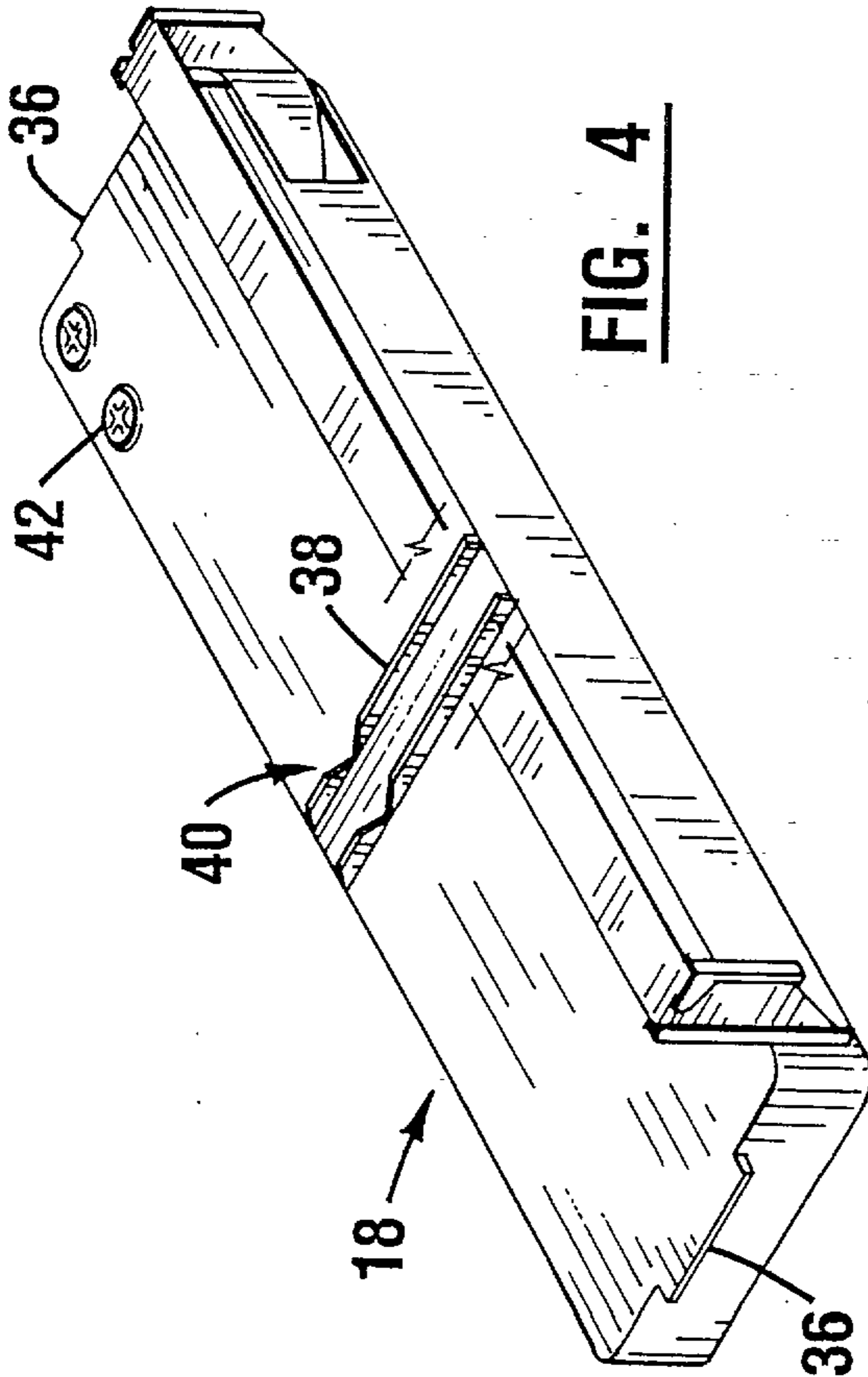

FIG. 4

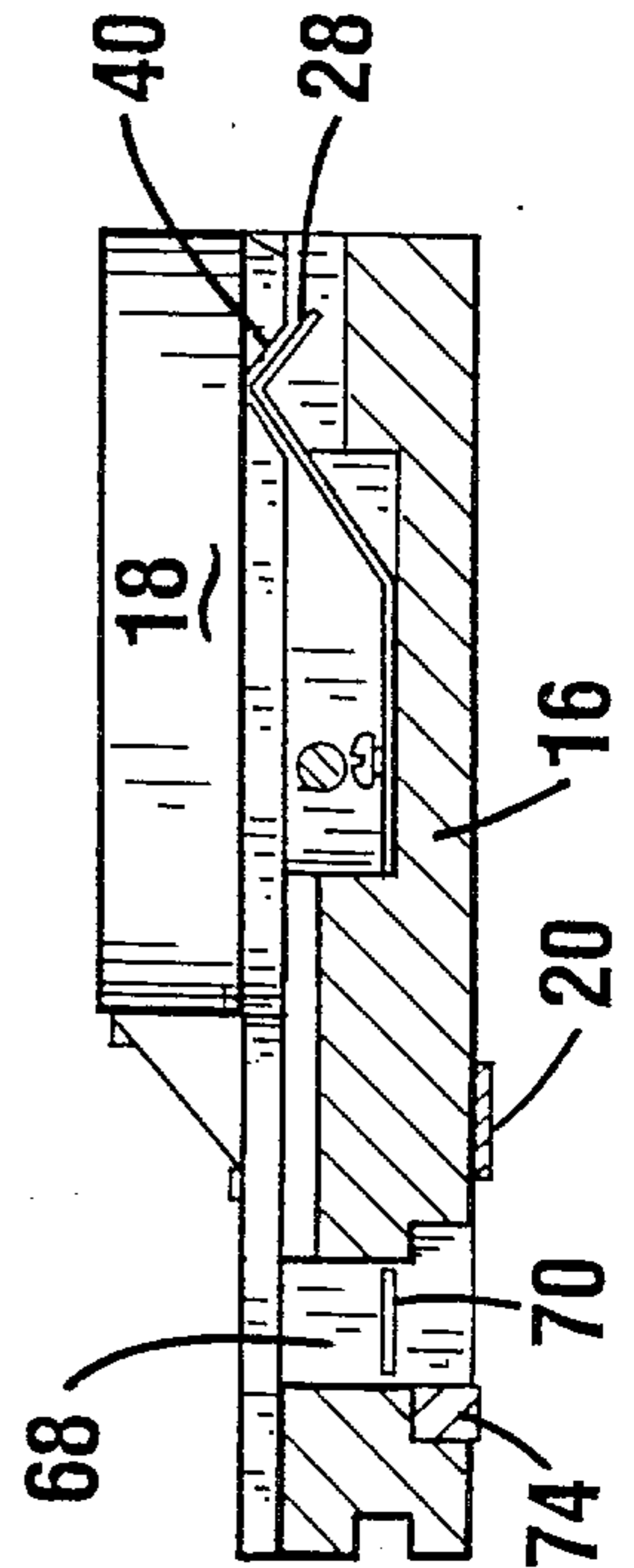

FIG. 5

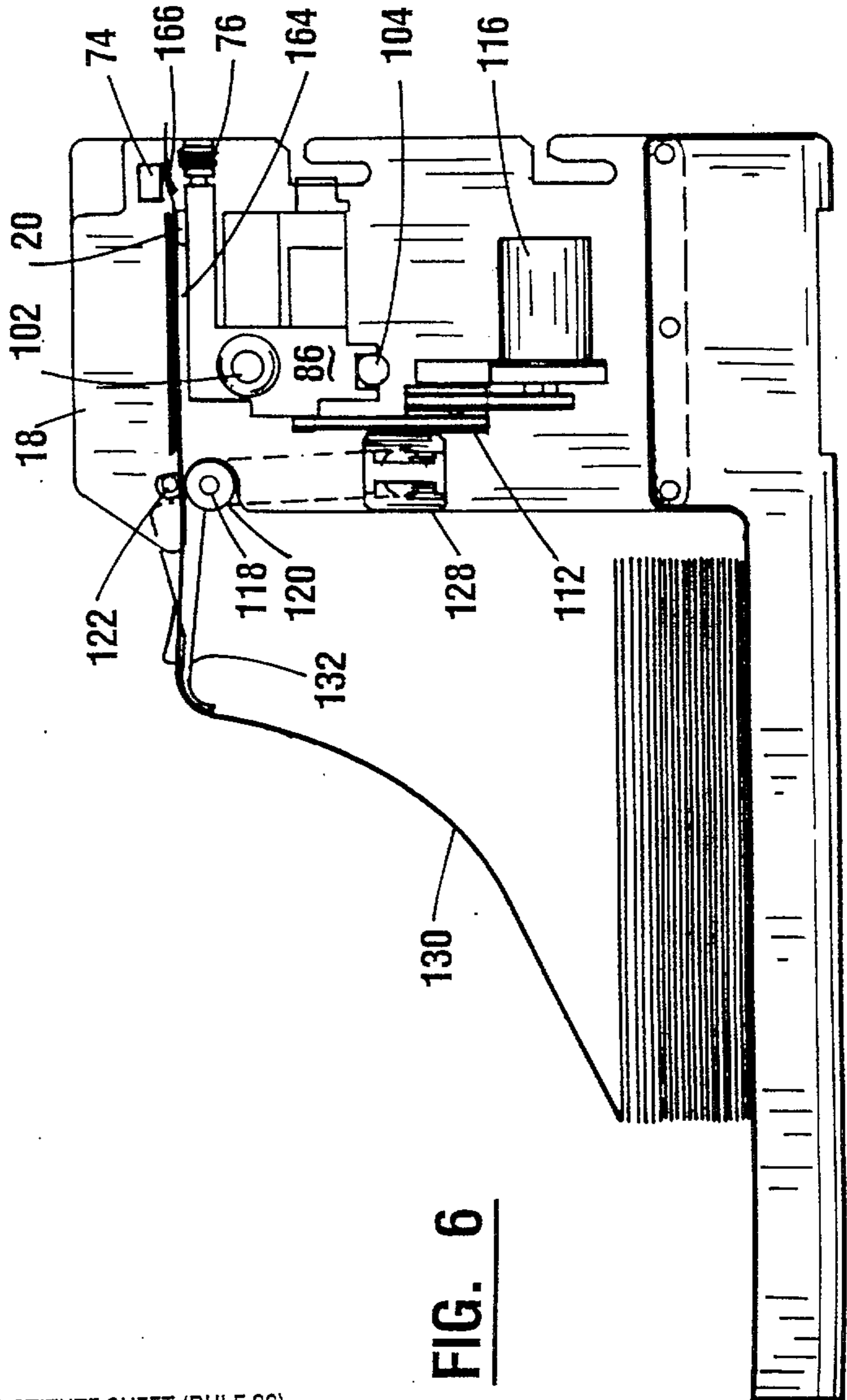

FIG. 6

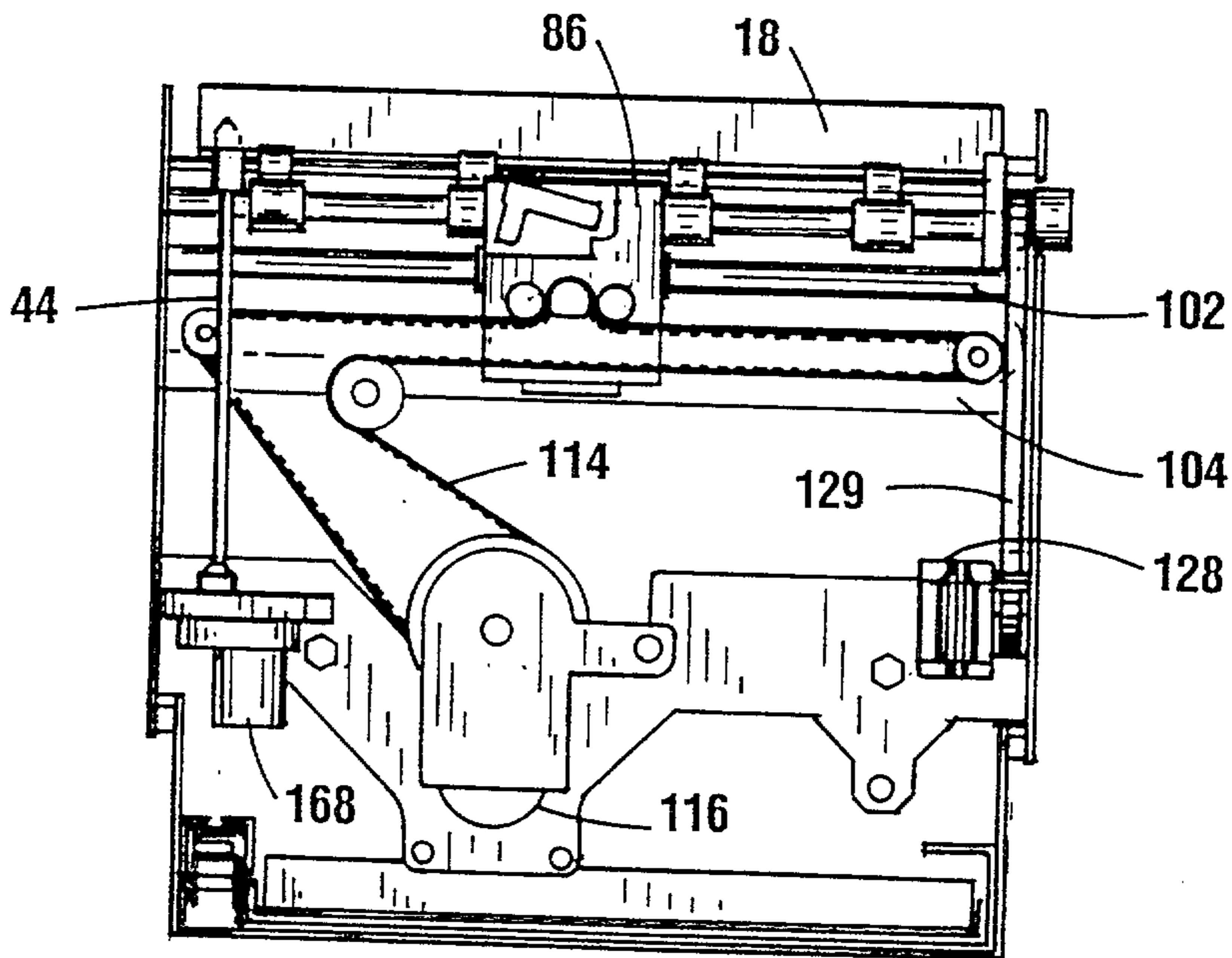

FIG. 7

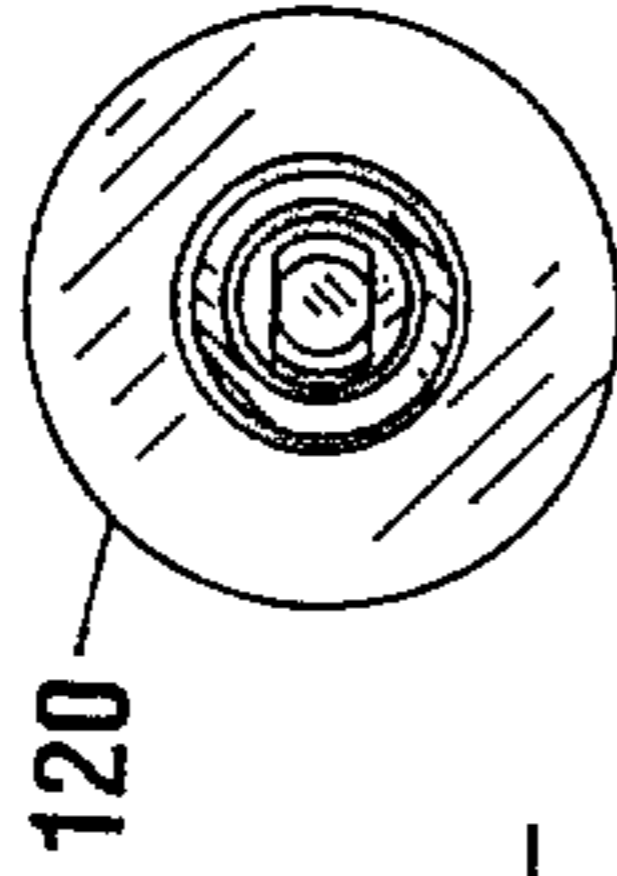

FIG. 9

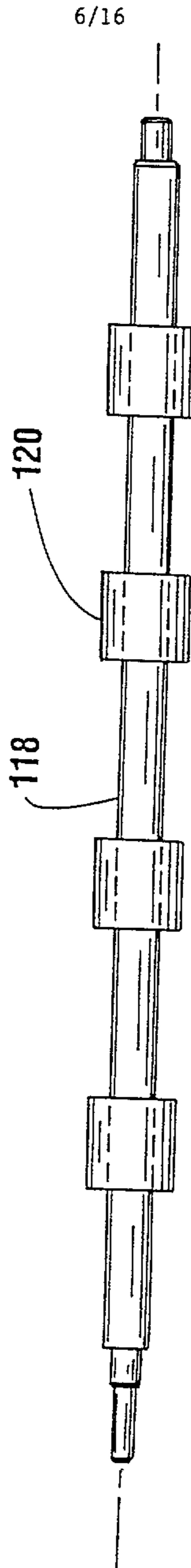

FIG. 8

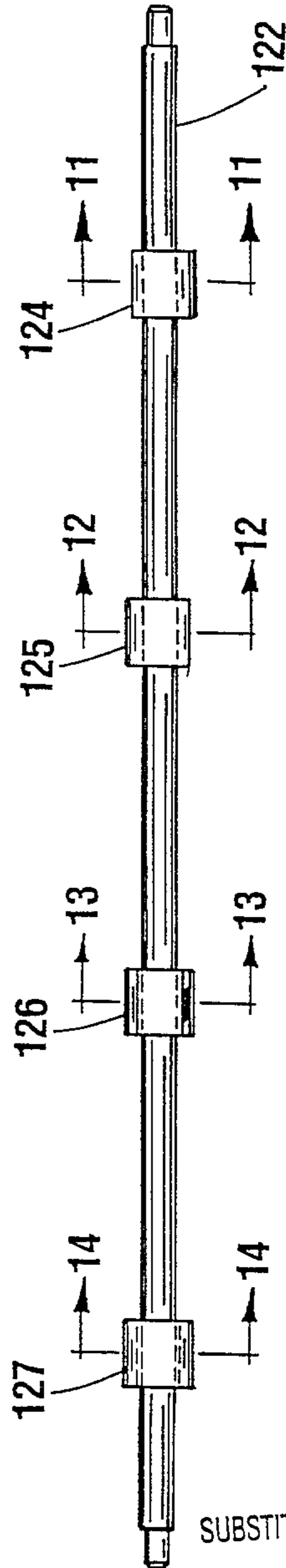

FIG. 10

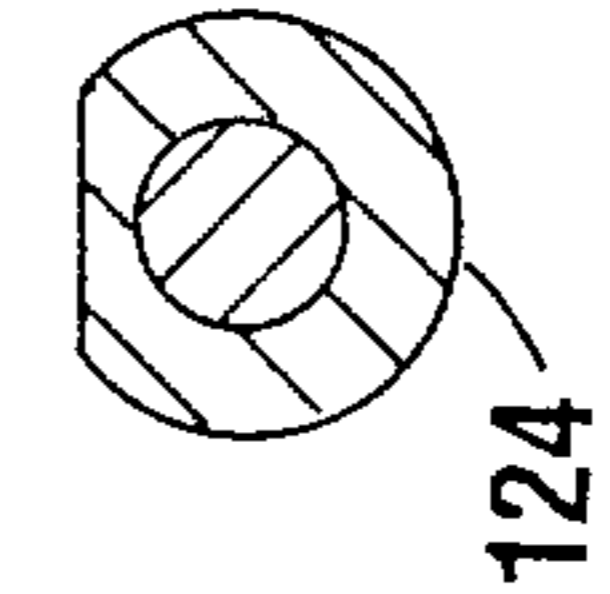

FIG. 11

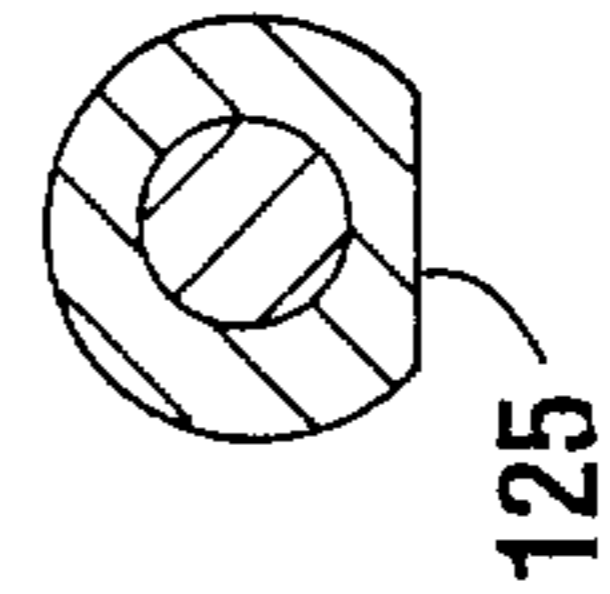

FIG. 12

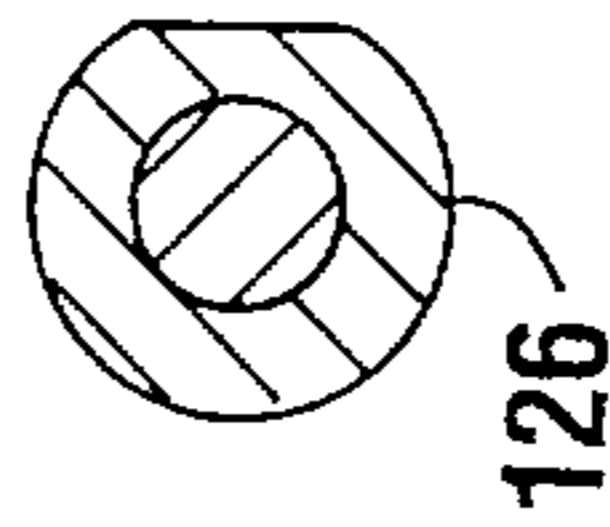

FIG. 13

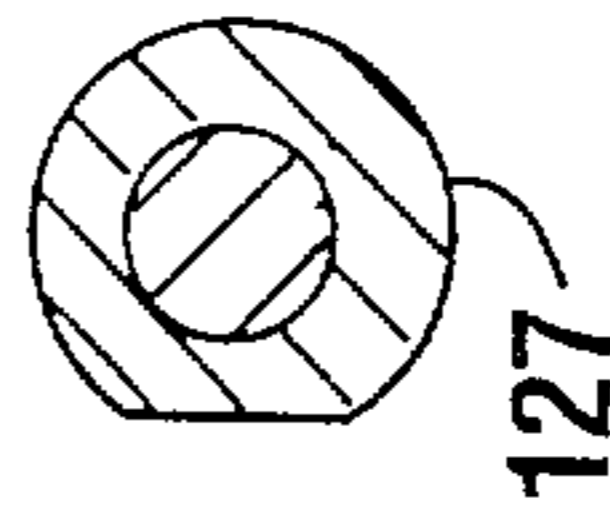

FIG. 14

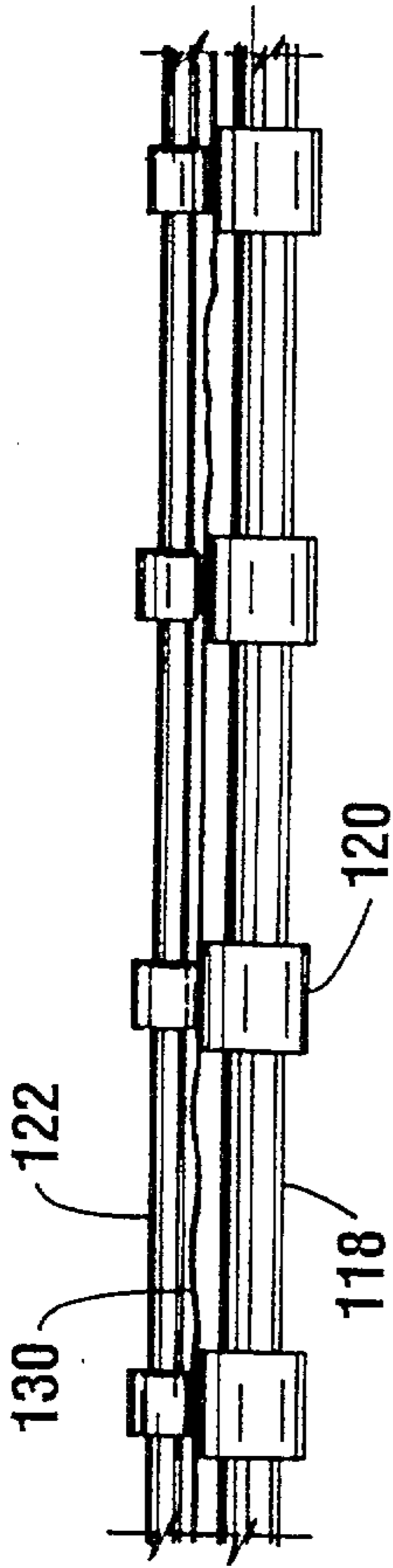

FIG. 15

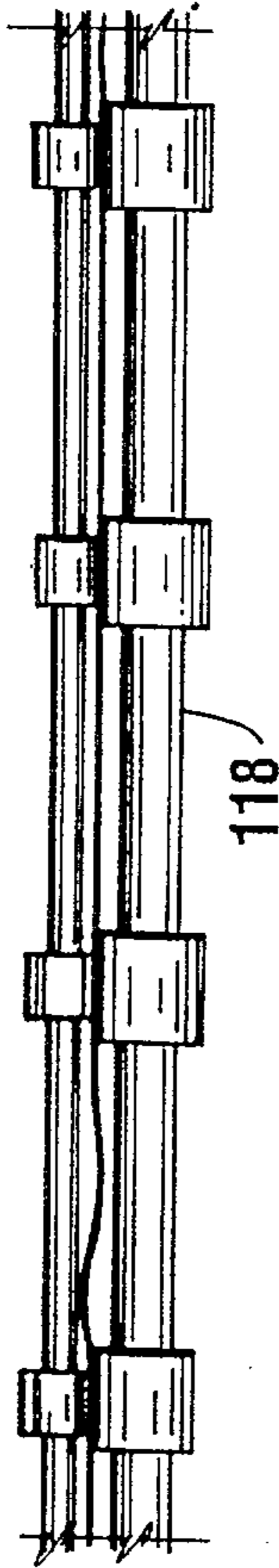

FIG. 16

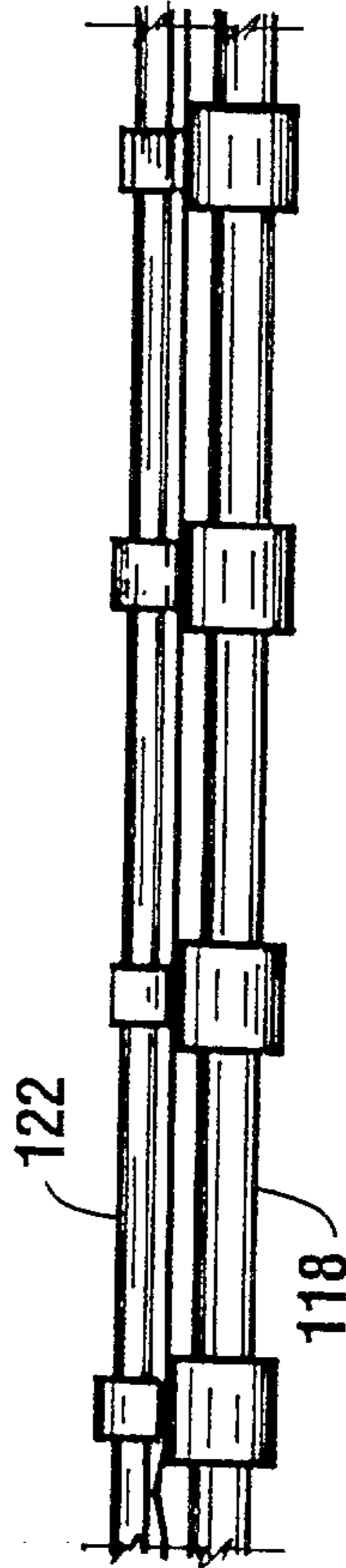

FIG. 17

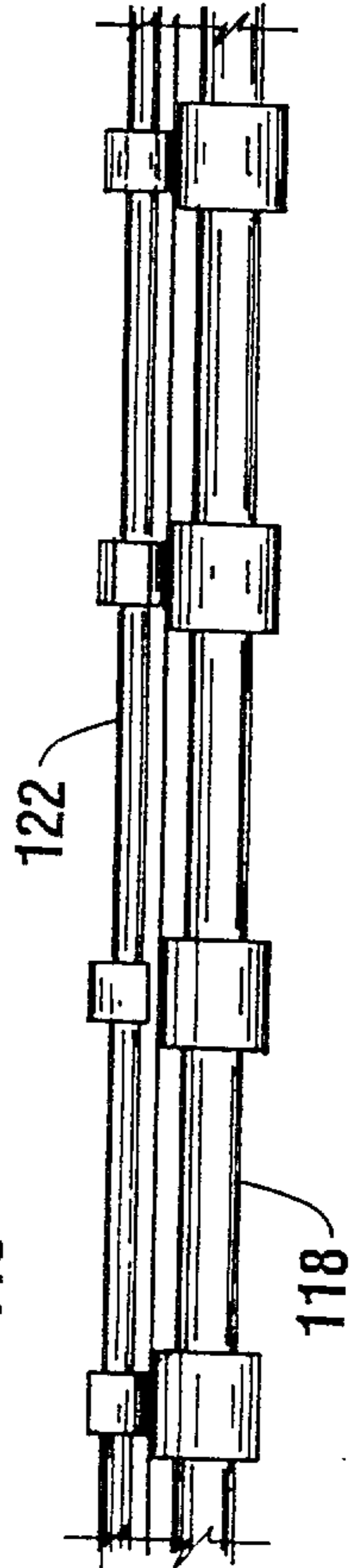

FIG. 18

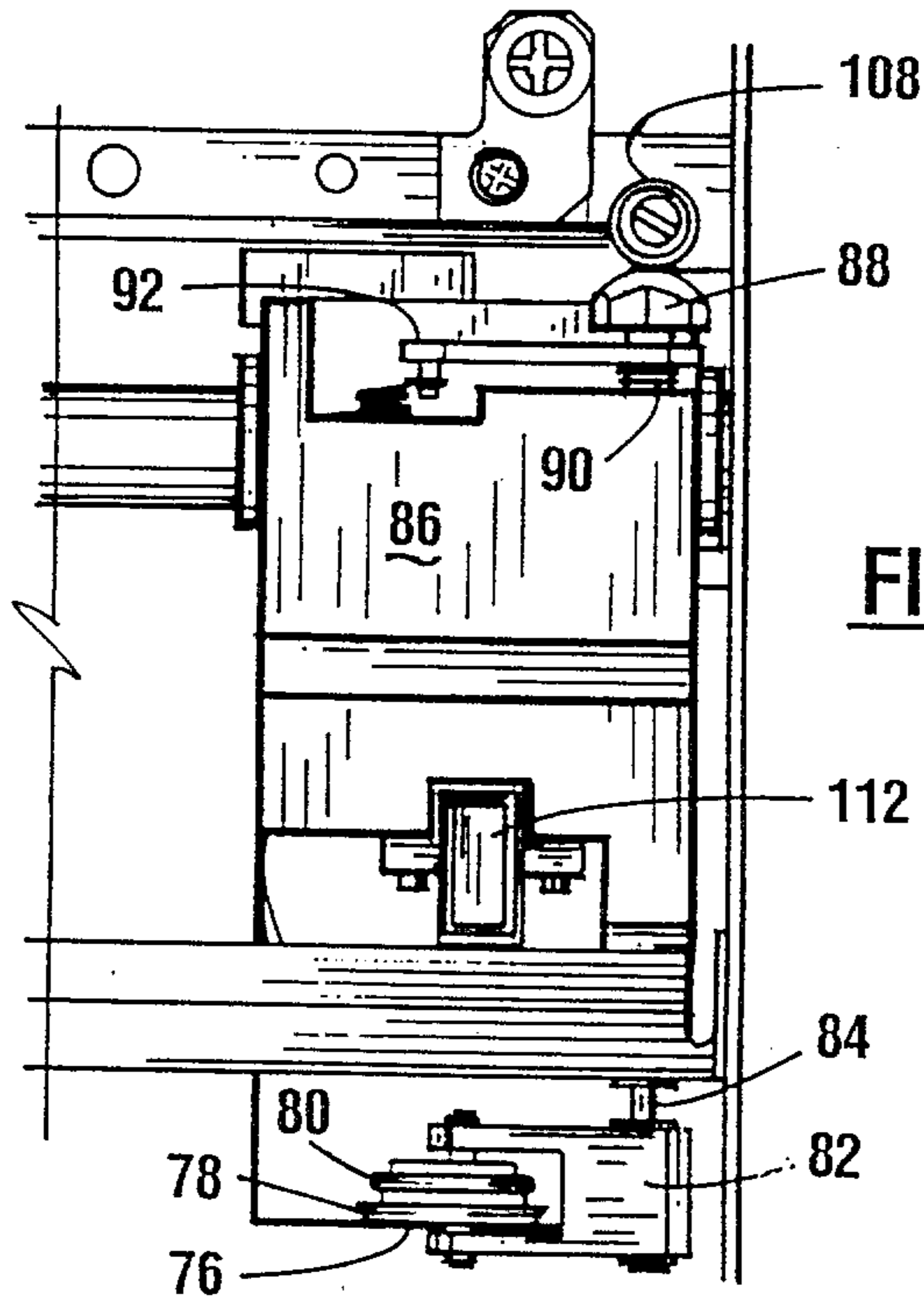

FIG. 19

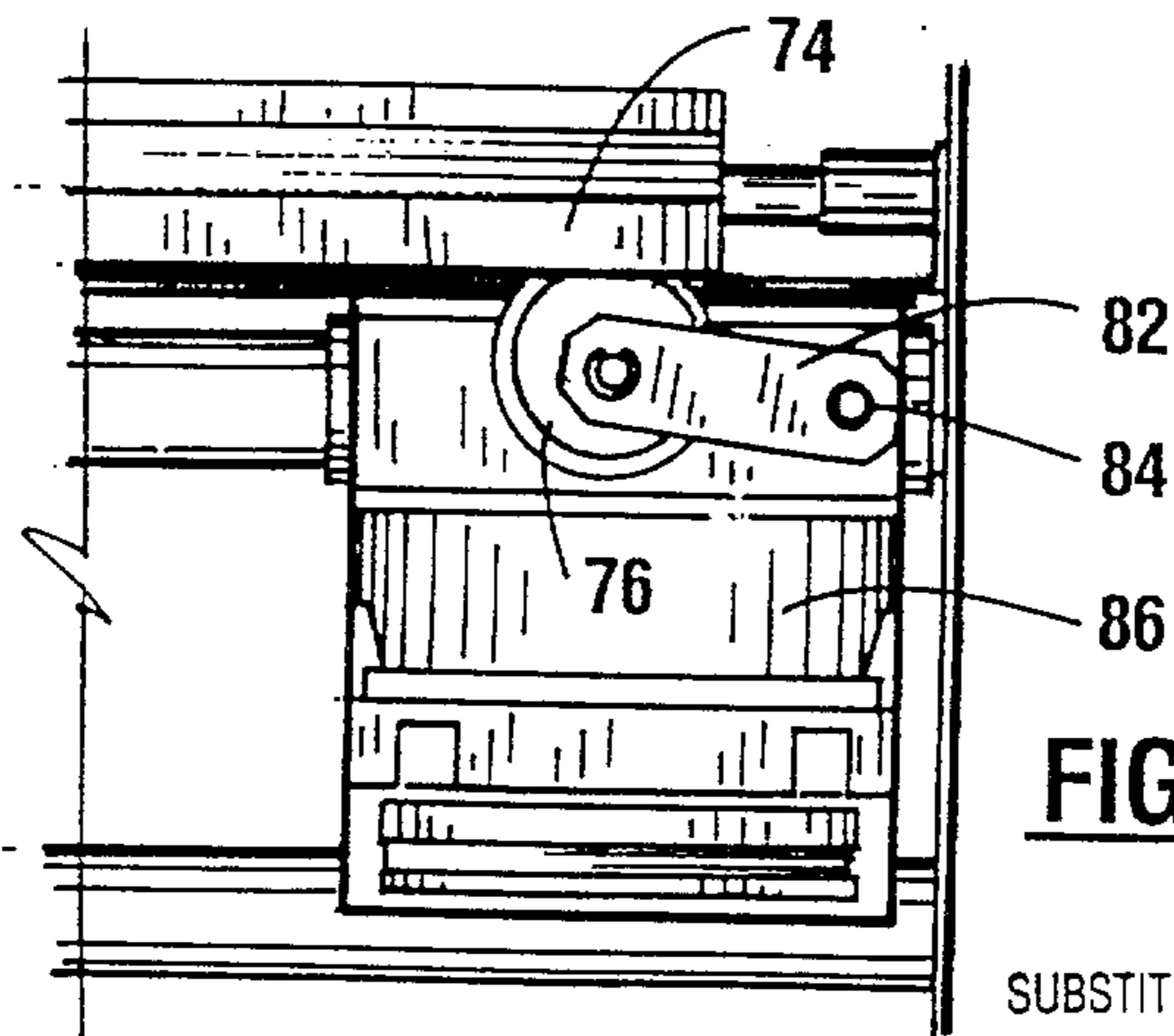

FIG. 20

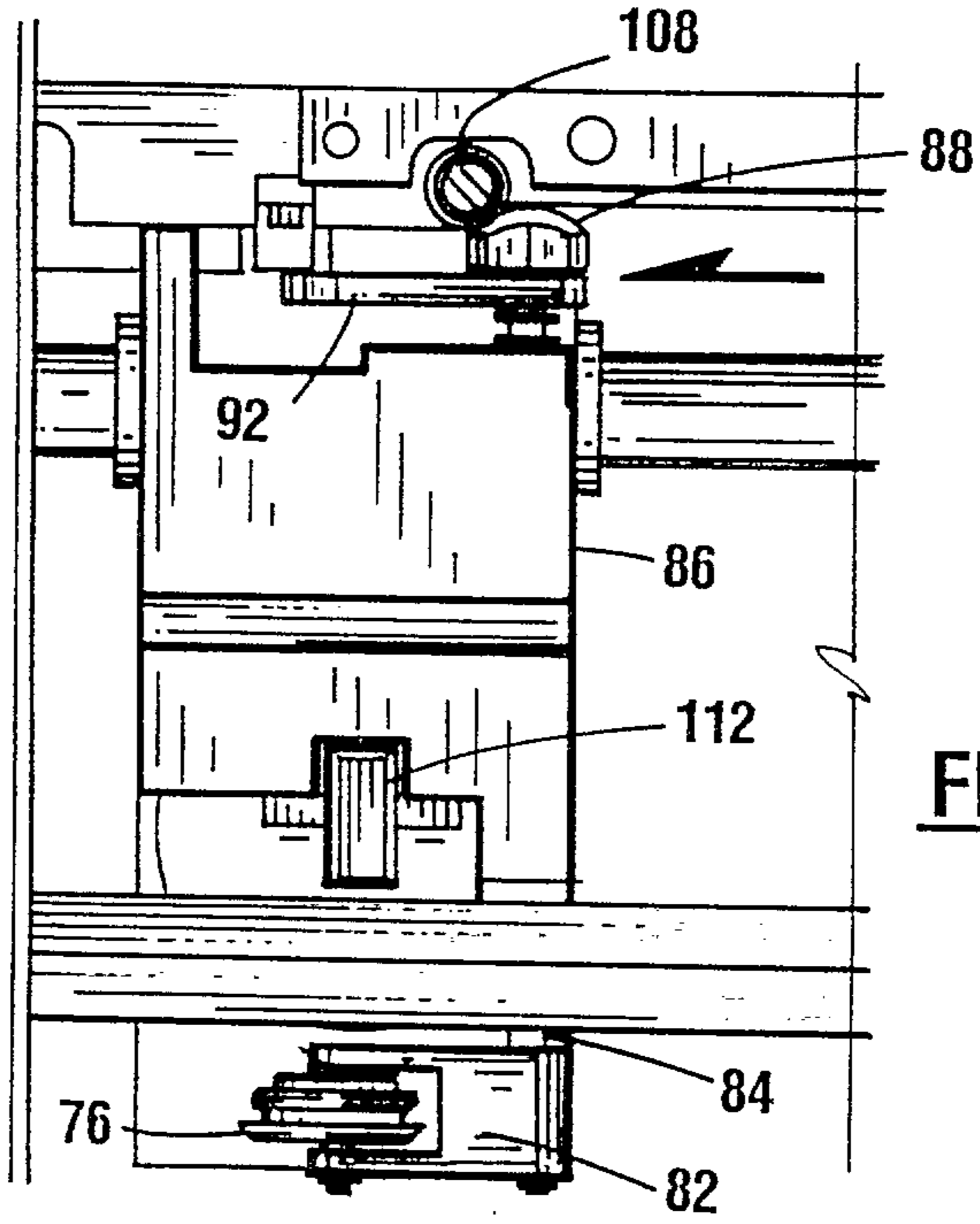

FIG. 21

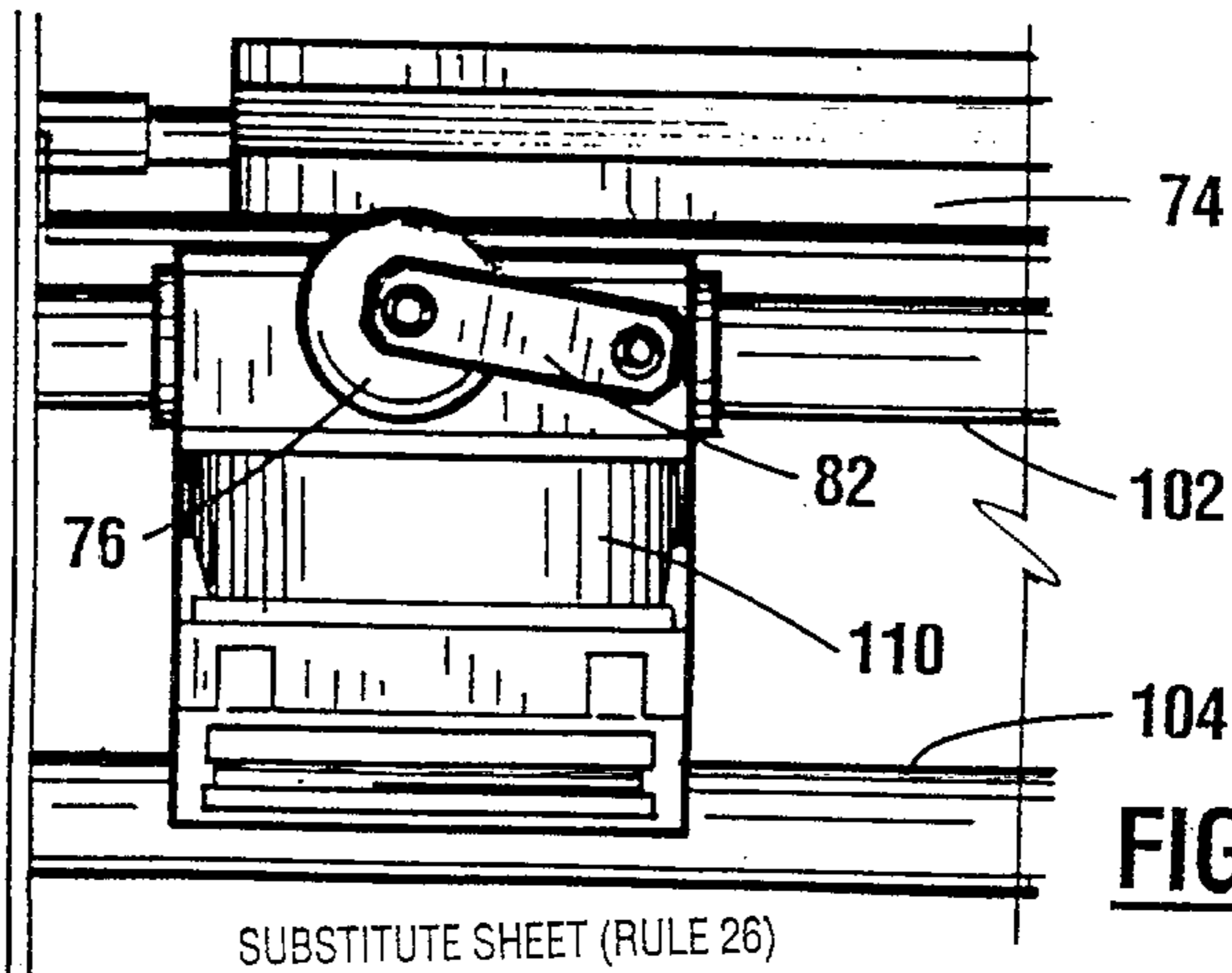

FIG. 22

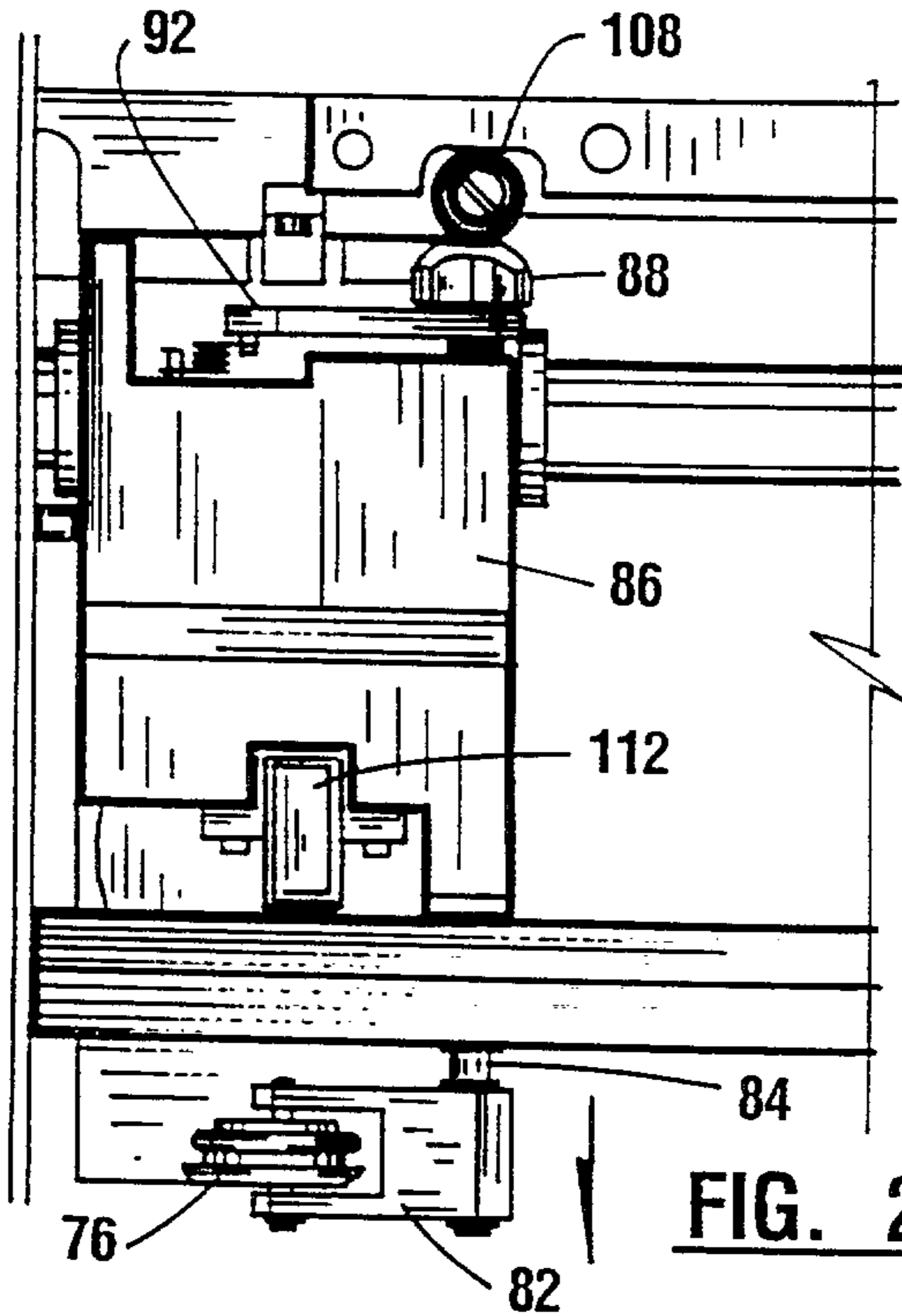

FIG. 23

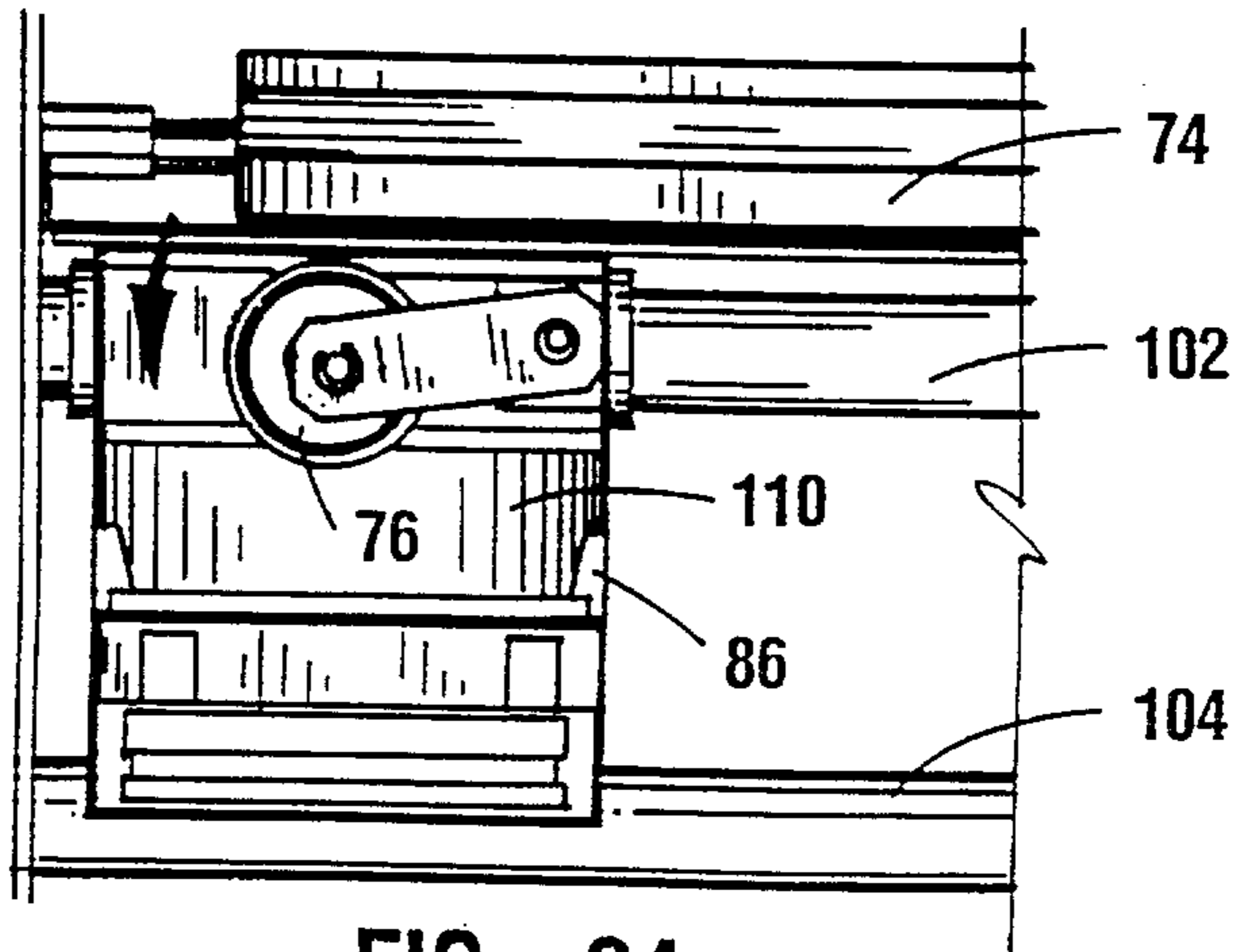

FIG. 24

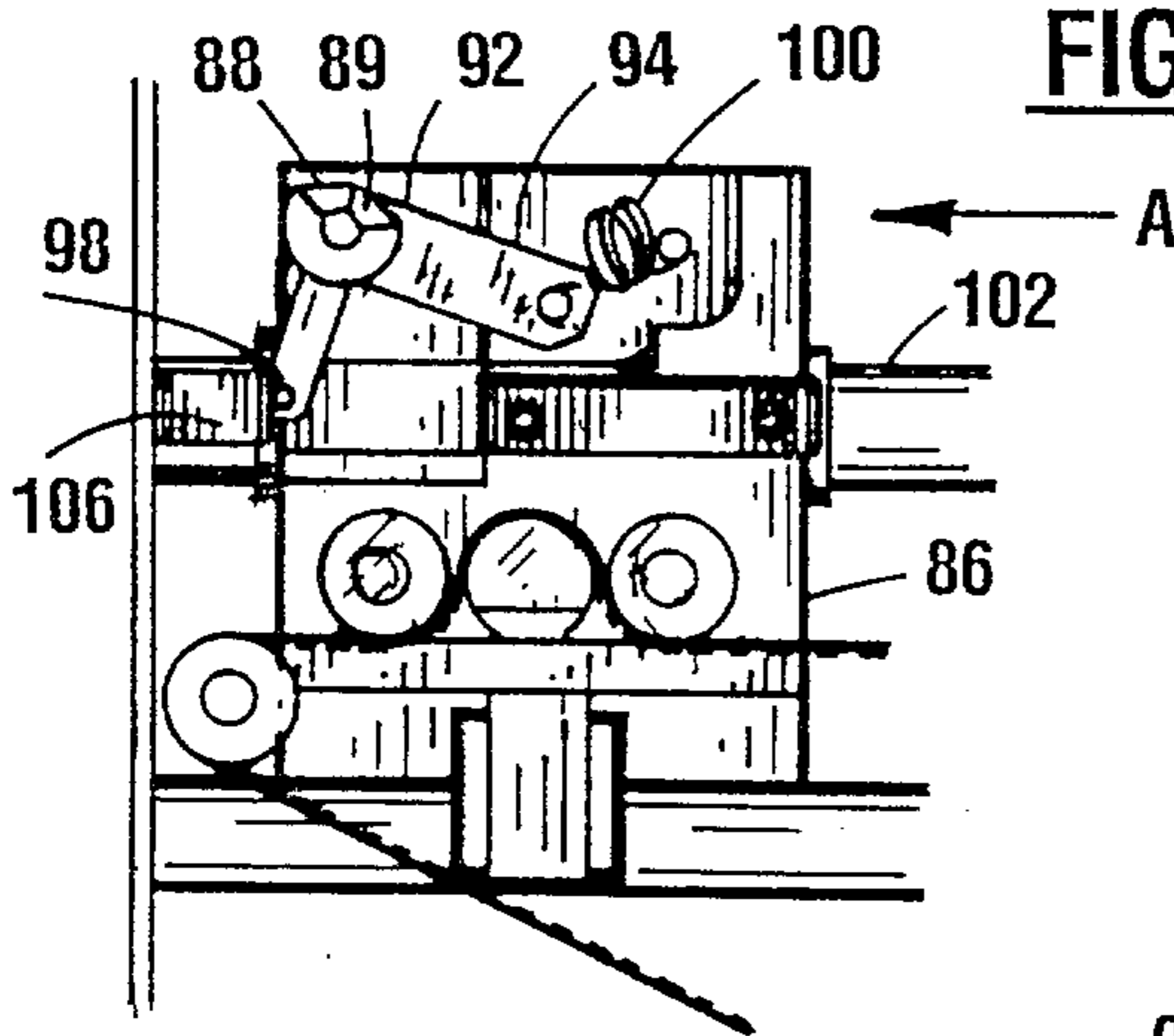

FIG. 26

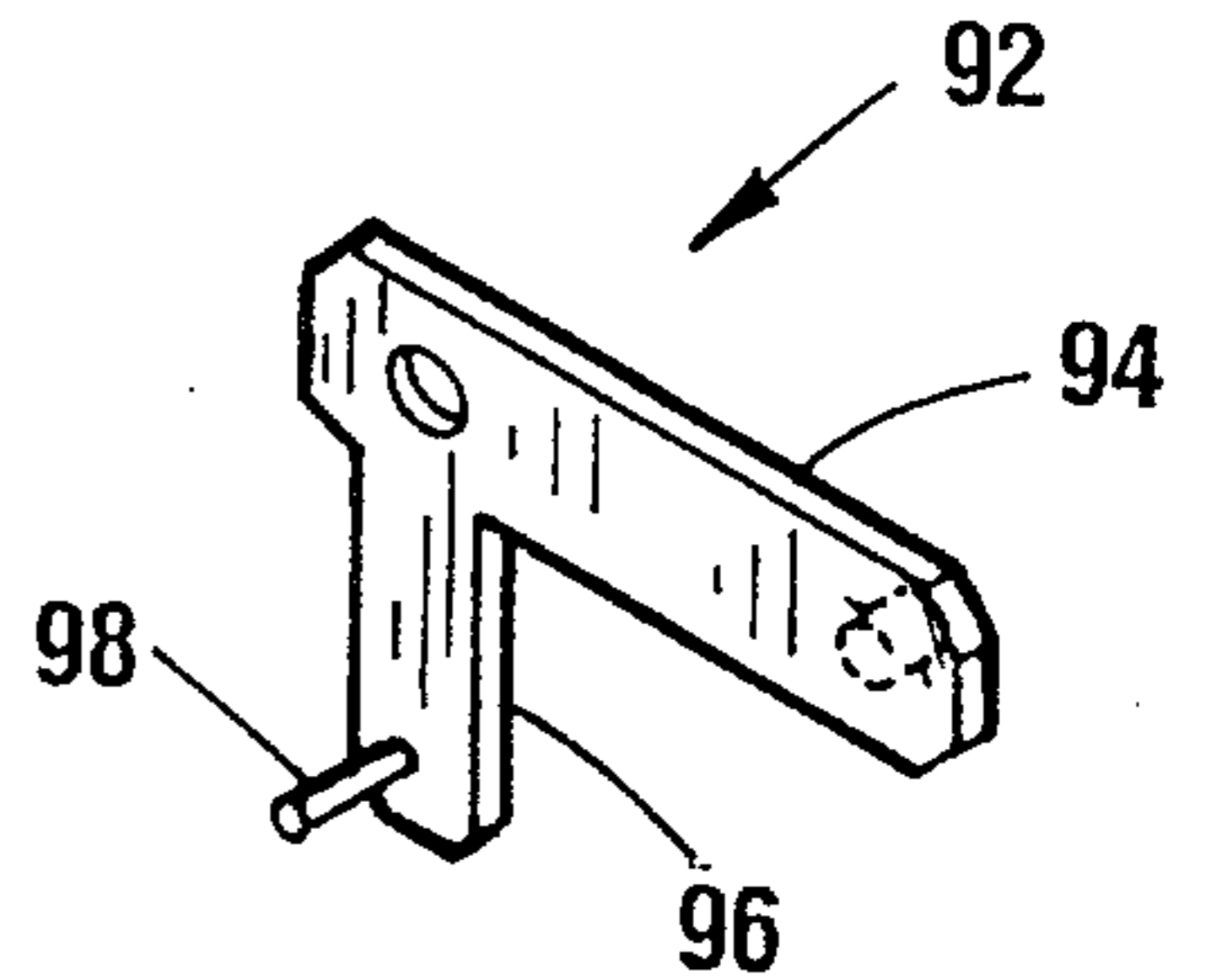

FIG. 27

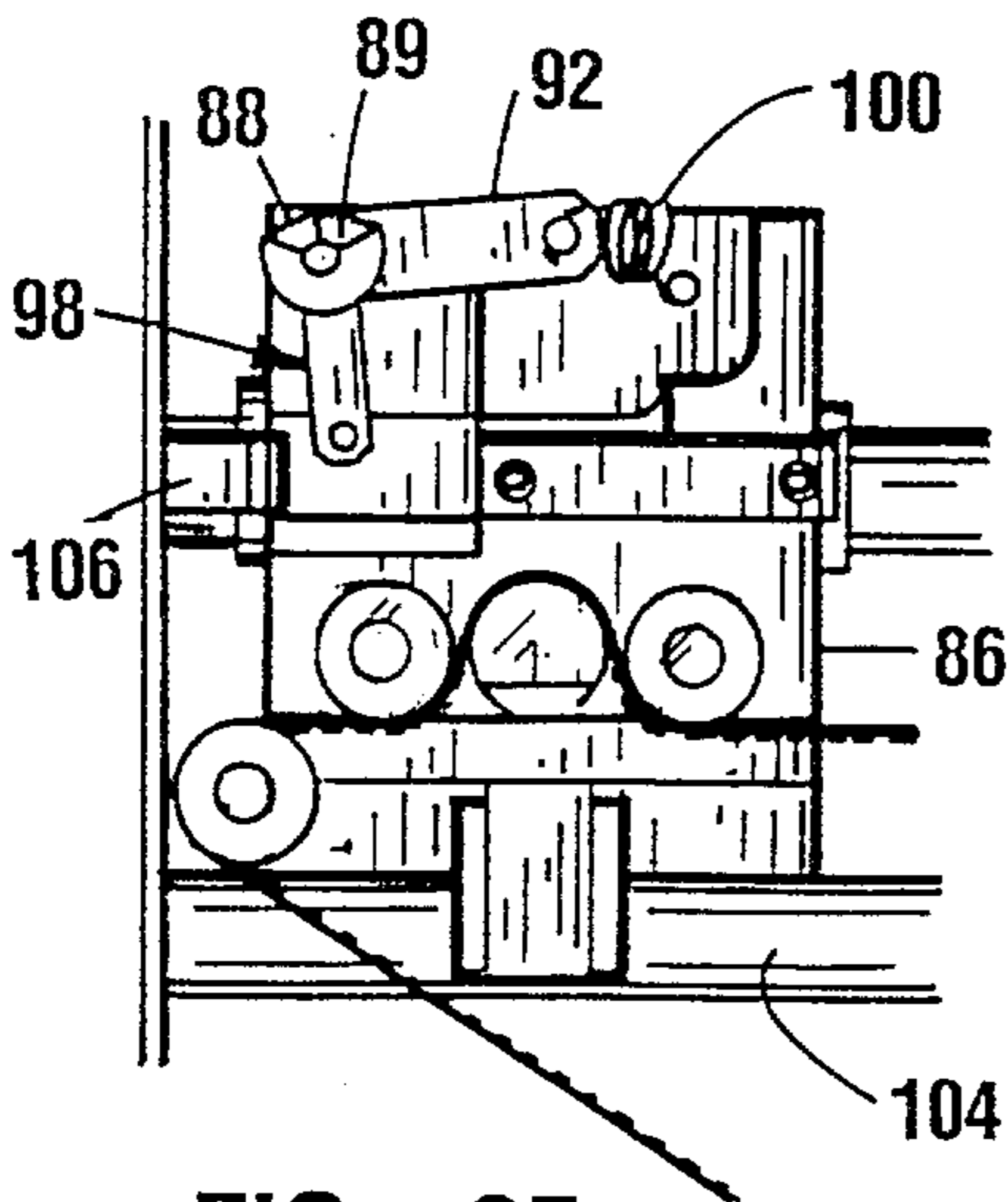

FIG. 25

13/16

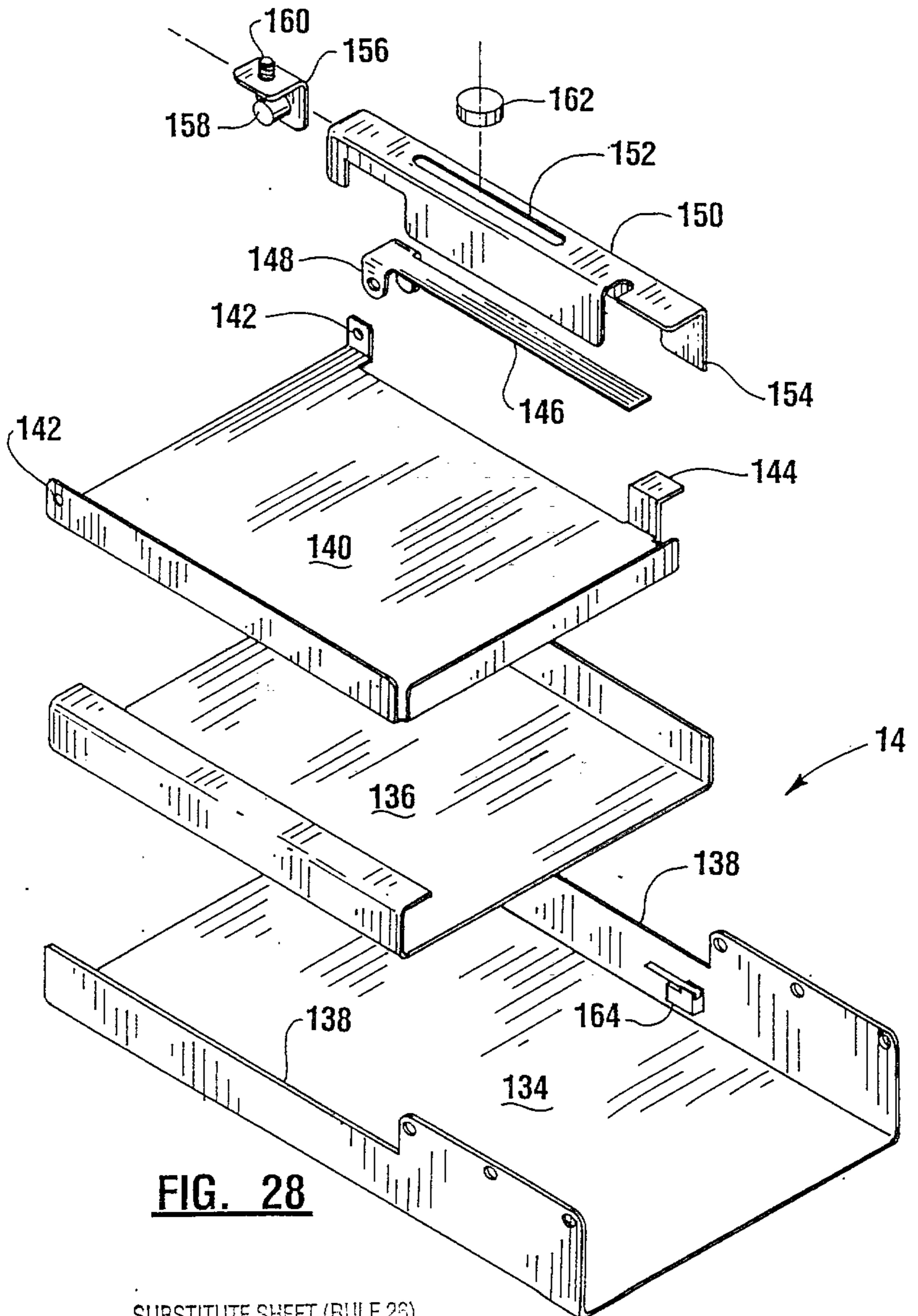

FIG. 28

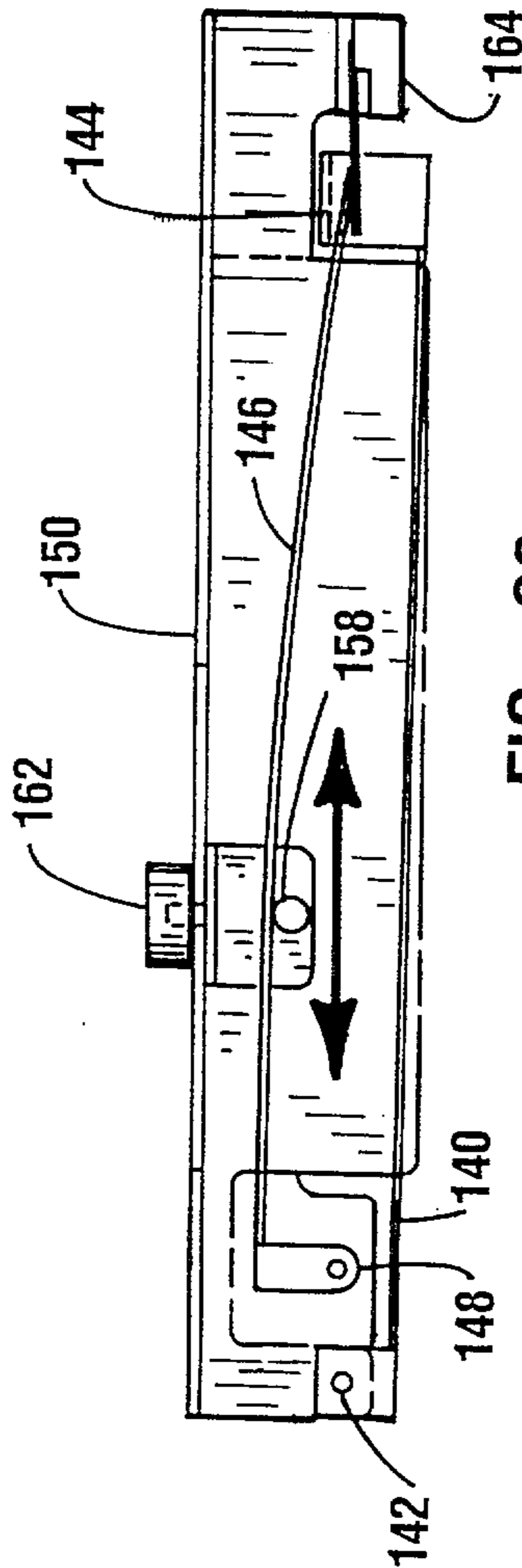

FIG. 29

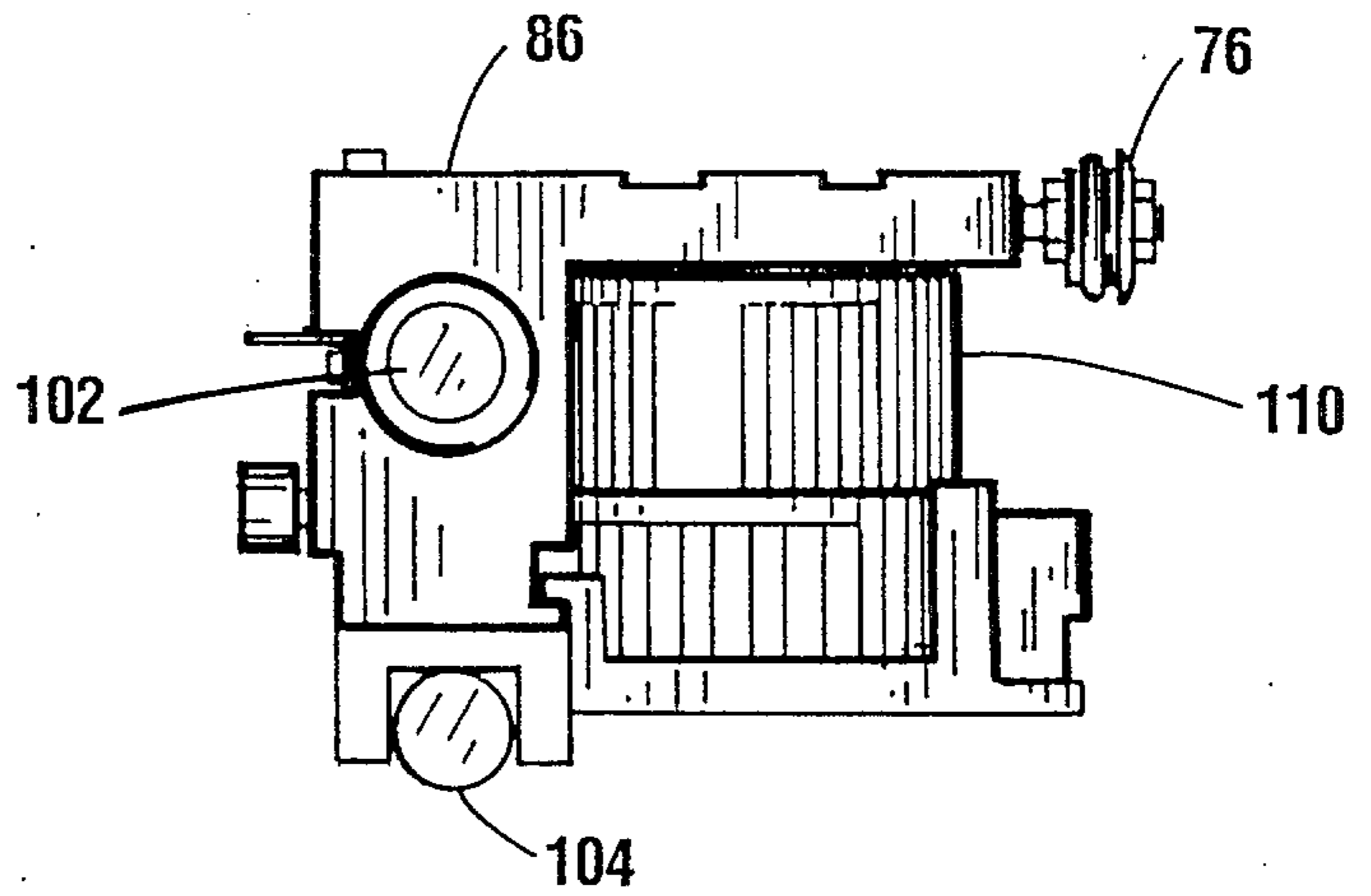

FIG. 30

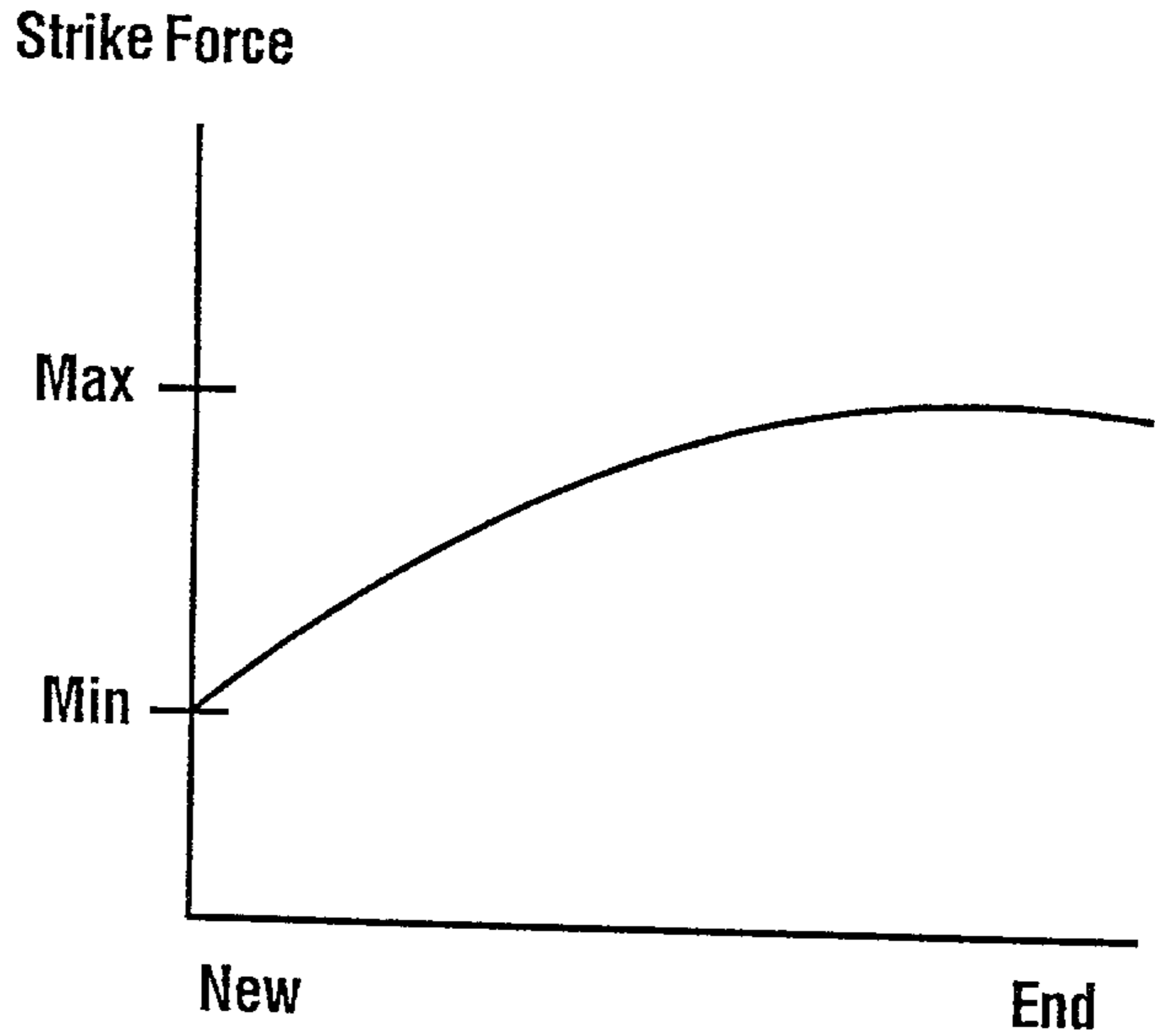

FIG. 32

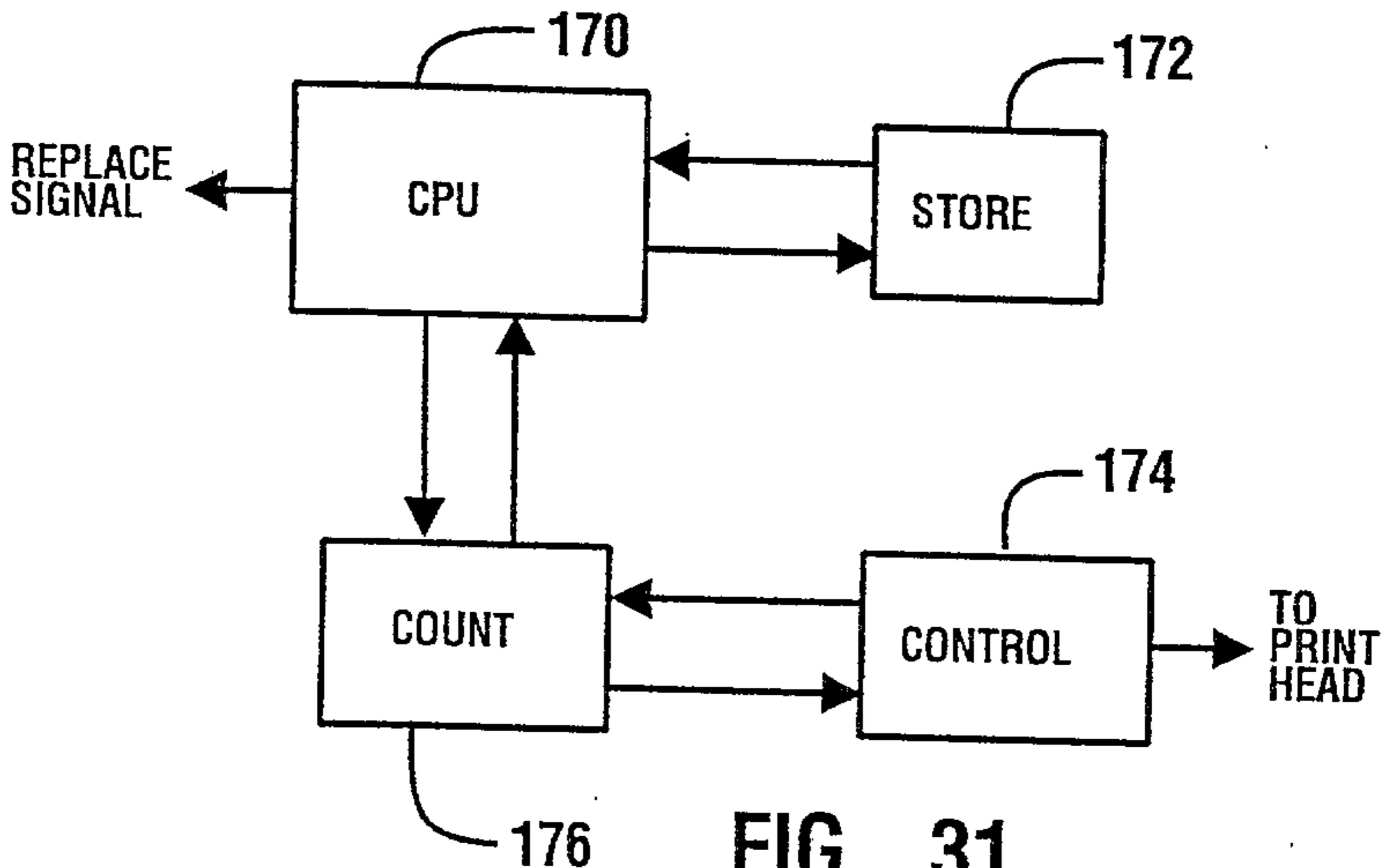

FIG. 31