



## INTERNATIONAL APPLICATION PUBLISHED UNDER THE PATENT COOPERATION TREATY (PCT)

<p>(51) International Patent Classification <sup>6</sup> : <b>H04N 7/24</b></p>	<p><b>A2</b></p>	<p>(11) International Publication Number: <b>WO 99/34601</b></p> <p>(43) International Publication Date: 8 July 1999 (08.07.99)</p>
<p>(21) International Application Number: PCT/JP98/05908</p> <p>(22) International Filing Date: 25 December 1998 (25.12.98)</p> <p>(30) Priority Data: 9/358546 25 December 1997 (25.12.97) JP</p> <p>(71) Applicant (for all designated States except US): KABUSHIKI KAISHA TOSHIBA [JP/JP]; 72, Horikawa-cho, Saiwai-ku, Kawasaki-shi, Kanagawa-ken 210-8572 (JP).</p> <p>(72) Inventors; and (75) Inventors/Applicants (for US only): OTOMO, Hitoshi [JP/JP]; 4-32-B302, Komaoka, Tsurumi-ku, Yokohama-shi, Kanagawa-ken 230-0071 (JP). TODOKORO, Shigeru [JP/JP]; 891-33, Kameino, Fujisawa-shi, Kanagawa-ken 252-0813 (JP). MIMURA, Hideki [JP/JP]; A-104, Marine-City-Kanazawabunko, 391, Shibacho, Kanazawa-ku, Yokohama-shi, Kanagawa-ken 236-0012 (JP).</p> <p>(74) Agents: SUZUYE, Takehiko et al.; Suzuye &amp; Suzuye, 7-2, Kasumigaseki 3-chome, Chiyoda-ku, Tokyo 100-0013 (JP).</p>		<p>(81) Designated States: CN, KR, US, European patent (DE, FR, GB).</p> <p><b>Published</b> <i>Without international search report and to be republished upon receipt of that report.</i></p>
<p>(54) Title: SYSTEM OF SHARING OBJECTS HAVING A PLURALITY OF CONTENTS</p>		
<p>(57) Abstract</p> <p>In order to use video contents created according to DVD video in DVD audio, audio and video sub-directories are located under a root directory. The video sub-directory includes video contents and their management information. The audio sub-directory includes audio contents and their management information. The video management information can only access the video contents. However, the audio management information can access not only the audio contents but also the video contents.</p>		

**FOR THE PURPOSES OF INFORMATION ONLY**

Codes used to identify States party to the PCT on the front pages of pamphlets publishing international applications under the PCT.

AL	Albania	ES	Spain	LS	Lesotho	SI	Slovenia
AM	Armenia	FI	Finland	LT	Lithuania	SK	Slovakia
AT	Austria	FR	France	LU	Luxembourg	SN	Senegal
AU	Australia	GA	Gabon	LV	Latvia	SZ	Swaziland
AZ	Azerbaijan	GB	United Kingdom	MC	Monaco	TD	Chad
BA	Bosnia and Herzegovina	GE	Georgia	MD	Republic of Moldova	TG	Togo
BB	Barbados	GH	Ghana	MG	Madagascar	TJ	Tajikistan
BE	Belgium	GN	Guinea	MK	The former Yugoslav Republic of Macedonia	TM	Turkmenistan
BF	Burkina Faso	GR	Greece	ML	Mali	TR	Turkey
BG	Bulgaria	HU	Hungary	MN	Mongolia	TT	Trinidad and Tobago
BJ	Benin	IE	Ireland	MR	Mauritania	UA	Ukraine
BR	Brazil	IL	Israel	MW	Malawi	UG	Uganda
BY	Belarus	IS	Iceland	MX	Mexico	US	United States of America
CA	Canada	IT	Italy	NE	Niger	UZ	Uzbekistan
CF	Central African Republic	JP	Japan	NL	Netherlands	VN	Viet Nam
CG	Congo	KE	Kenya	NO	Norway	YU	Yugoslavia
CH	Switzerland	KG	Kyrgyzstan	NZ	New Zealand	ZW	Zimbabwe
CI	Côte d'Ivoire	KP	Democratic People's Republic of Korea	PL	Poland		
CM	Cameroon	KR	Republic of Korea	PT	Portugal		
CN	China	KZ	Kazakstan	RO	Romania		
CU	Cuba	LC	Saint Lucia	RU	Russian Federation		
CZ	Czech Republic	LI	Liechtenstein	SD	Sudan		
DE	Germany	LK	Sri Lanka	SE	Sweden		
DK	Denmark	LR	Liberia	SG	Singapore		
EE	Estonia						

## D E S C R I P T I O N

SYSTEM OF SHARING OBJECTS HAVING  
A PLURALITY OF CONTENTS

5

## Technical Field

The present invention relates to a system for sharing objects of a plurality of contents (various video contents, various audio contents, and the like).

10

## Background Art

Also, the present invention relates to an information medium having management data for sharing objects of a plurality of contents, an apparatus for playing back information recorded on the medium, a method of recording information containing the management data on  
15 the medium, and a method of playing back information from the medium on the basis of the management data.

20

As optical discs that can record video (moving picture) data with high quality and at high density, and can record various kinds of information such as multiangle video data, sub-picture data, multilingual audio data, multichannel audio data, and the like, DVD video discs have been developed, and are beginning to be put into the market (DVD is an abbreviation for  
25 a digital versatile disc).

The DVD video disc standards can support compressed multichannel audio (AC-3, MPEG, and the like) and non-compressed linear PCM (from a sampling

rate of 48 kHz/16 quantization bits to a sampling rate of 96 kHz/24 quantization bits). Linear PCM of DVD video has high-sound quality specifications with high sampling rate and high quantization bits superior to conventional music CDs (a sampling rate of 44.1 kHz/16 quantization bits). Especially, linear PCM having a sampling rate of 96 kHz/20 to 24 quantization bits qualifies for the next generation digital audio discs (so-called super CDs or super audio discs).

However, DVD video specifications give priority to video over audio, and audio priority specifications superior to audio specifications of DVD video in terms of not only the sampling frequency and the number of quantization bits but also the number of recordable channels, recordable time, and the like, are yet to come.

To meet such demand, DVD audio specifications are being explored (however, the DVD audio specifications are not yet a prior art). The DVD audio specifications can support up to linear PCM having a sampling rate of 192 kHz and 24 quantization bits as well as linear PCM having a sampling rate of 48 kHz to 96 kHz and 16 to 24 quantization bits. In the future version up of DVD audio specifications, higher-sound quality specifications may be introduced.

DVD audio can cope with such future scale-up since it can commonly use some specifications of DVD video

capable of large-amount recording that includes even digital Hi-Vision video as a target.

Also, DVD audio can take future technical, market, and economic advantages that will become available  
5 along with the improvement of DVD video.

For example, when a large-amount DVD disc which will be available in the future in DVD video is used in DVD audio, the sampling frequency, the number of quantization bits, the number of recording channels,  
10 and the like used in recording can be increased considerably if the recording time remains the same. The technique of a DVD video recorder which will be put into the market in the near future and uses a DVD-RAM (or rewritable DVD-RW or write-once DVD-R) can be used  
15 in a DVD audio recorder that will become available soon.

Furthermore, if the market scale expands as DVD video prevails, media (DVD-ROM discs, DVD-RAM/DVD-RW discs, DVD-R discs, and the like), components (disc drive, optical pickup, various ICs, and the like),  
20 various control programs, and the like are standardized, and a cost reduction of DVD audio products having many features and high sound quality is promoted. With the spread of DVD audio, DVD video can also take future technical, market, and economical advantages that will  
25 become available along with the improvement of DVD audio.

As a management method for controlling playback of

video (moving picture) or audio (music or the like) contents, it is a common practice to manage playback of contents produced according to their purposes. By contrast, with recent diversification of users' requirements, video and music have vague boundary, and requirements for partly using the contents that can be independently played back as video in music or for commonly using contents by allowing video created for music to be played back as video alone are increasing among producers of these contents (contents providers).

The DVD audio specifications according to the present invention can meet such requirements of the contents providers. More specifically, the DVD audio specifications normally give priority to audio over video, but it is possible to build a system compatible with both DVD video and DVD audio. That is, the DVD audio specifications can provide an audio only disc (A disc) including DVD audio contents alone, and an audio + video disc (AV disc) including both audio and video contents. In such case, upon playing back the audio contents of an AV disc, its video contents can also be accessed.

In the DVD audio specifications according to the present invention, not only video picture data as subsets of the DVD video specifications, but also high-resolution still picture data, text information, and menu data (visual menu data that can be freely designed

by the contents provider) can be added to audio data with high-sound quality specifications.

#### Disclosure of Invention

It is the first object of the present invention to provide a digital information medium which can access not only DVD audio information but also part (e.g., some video data) of DVD video information in the aforementioned DVD audio specifications.

It is the second object of the present invention to provide an apparatus for playing back information from the digital information medium.

It is the third object of the present invention to provide a method of recording information on the digital information medium.

It is the fourth object of the present invention to provide a method of playing back information from the digital information medium.

In order to achieve the first object, in a digital information medium according to the present invention, first and second contents (ATS, VTS) for different purposes are recorded on a plurality of independent areas (DVD audio zone, DVD video zone). The first and second contents (ATS, VTS) respectively have first and second management blocks (AMG, VMG) to manage playback of their contents. The first management block (AMG) has first information (AMGI) for managing accesses to both the first contents (ATS) and second contents (VTS).

In the medium of the first object, the second management block (VMG) may have second information (VMGI) for managing accesses to the second contents (VTS).

5 In the medium of the first object, the first management block (AMG) has physically or logically smaller address numbers than the second management block (VMG) or the second contents (VTS).

10 In the medium of the first object, the first contents (ATS#1) may include information (link information) for accessing the second contents (VTS).

In the medium of the first object, files of recorded information may be managed by a hierarchical file structure including the following sub-directories and root directory. That is, recorded information files can be managed by: a first sub-directory (ATS directory) including a data file (ATS\_01\_0.AOB) for storing the first contents (ATS) and a data file (AUDIO\_TS.IFO) for storing the first information (AMGI); a second sub-directory (VTS directory) including a data file (VTS\_01\_1.VOB) for storing the second contents (VTS) and a data file (VIDEO\_TS.IFO) for storing the second information (VMGI); and a root directory containing the first sub-directory (ATS directory) and the second sub-directory (VTS directory).

15

20

25

In the medium of the first object, the data file (ATS\_01\_0.AOB) in the first directory (ATS directory)

may be formed by objects (AOTT) which contain at least audio data but do not contain video data); and the data file (VTS\_01\_1.VOB) in the second sub-directory (VTS directory) may be formed by objects (VTS) which contain  
5 video data.

In the medium of the first object, the first information (AMGI) may contain first search information (ATT\_SRP for AOTT) for accessing the objects (AOTT) which contain audio data but do not contain any video  
10 data, and second search information (ATT\_SRP for AVTT) for accessing the objects (VTS) containing video data.

In the medium of the first object, the second information (VMGI) may contain search information (ATT\_SRP for AVTT) for accessing only the objects (VTS)  
15 containing video data.

In order to achieve the first object, an optical disc according to the present invention has a lead-in area (27) at the center, and a volume space (28) and lead-out area (26) in turn around the lead-in area; the  
20 volume space (28) contains an audio zone (71) and then a video zone (72); the audio zone (71) contains audio management information (AMG) and audio contents (ATS); and the video zone (72) contains video management information (VMG) and video contents (VTS). In this  
25 optical disc, the audio contents (ATS) and video contents (VTS) can contain data cells (VTS\_C#2 and the like) which are commonly managed by the audio

management information (AMG).

In the optical disc of the first object, the video contents (VTS) can contain data cells (VTS\_C#2 and the like) managed by the video management information (VMG),  
5 and each of the data cells (VTS\_C#2 and the like) managed by the audio management information (AMG) or video management information (VMG) can be formed by a set of data packs each having a predetermined size (2,048 bytes).

10 Furthermore, in order to achieve the first object, another optical disc according to the present invention has a lead-in area (27) at the center, and a volume space (28) and lead-out area (26) in turn around the lead-in area; the volume space (28) contains an audio  
15 zone (71) and then a video zone (72); the audio zone (71) contains audio management information (AMG) and audio contents (ATS); and the video zone (72) contains video management information (VMG) and video contents (VTS). In this optical disc, the audio contents (ATS)  
20 contain one or more data cells (audio cell, picture cell, silent cell) managed by the audio management information (AMG), and each data cell (audio cell, picture cell, silent cell) is formed by a set of one or more data packs (A\_PCK, SPCT\_PCK, and the like) each  
25 having a predetermined size (2,048 bytes).

In the other optical disc of the first object, at least one data cell (audio cell) can be formed by packs

(A\_PCK) of audio information.

In the other optical disc of the first object,  
at least one data cell (silent cell) can be formed by  
packs (A\_PCK) of audio information consisting of silent  
5 information.

In the other optical disc of the first object,  
the audio contents (ATS) may contain audio title set  
information (ATSI) for managing its contents, the audio  
title set information (ATSI) may contain program chain  
10 information (ATS\_PGCI in ATS\_PGCIT) for managing one or  
more programs (PG#) that form the audio contents (ATS),  
and the program chain information (ATS\_PGCI) may  
contain information (ATS\_C\_SA, ATS\_C\_EA in FIG. 28)  
indicating the recorded positions of the data cells  
15 (audio cell, picture cell, silent cell).

In the other optical disc of the first object, the  
audio contents (ATS) can contain an audio title set  
(ATT or AVTT) which includes information pertaining to  
both audio and video, and an audio only title set  
20 (AOTT) which includes information pertaining to only  
audio.

In the other optical disc of the first object,  
the audio management information (AMG) can contain  
information (ATT\_SRPT in FIG. 20, the location of which  
is specified by ATT\_SRPT\_SA in AMGI\_MAT in FIG. 18) of  
25 a search pointer (ATT\_SRP) for accessing the audio  
title set (ATT).

In the other optical disc of the first object, the audio management information (AMG) can contain information (AOTT\_SRPT in FIG. 20, the location of which is specified by AOTT\_SRPT\_SA in AMGI\_MAT in FIG. 18) of a search pointer (AOTT\_SRP) for accessing the audio only title set (AOTT).

In the other optical disc of the first object, the audio contents (ATS) can contain audio data (AOTT\_AOB) digitally converted by a predetermined sampling frequency (e.g., 192 kHz) selected from a plurality of different sampling frequencies (48 kHz, 96 kHz, 192 kHz, and the like) and a predetermined number of quantization bits (e.g., 20 bits) selected from a plurality of different numbers of quantization bits (16 bits, 20 bits, 24 bits, and the like), and attribute information (AOTT\_AOB\_ATR in FIG. 25 included in ATSI in FIG. 24) indicating the predetermined sampling frequency (e.g., 192 kHz) and the predetermined number of quantization bits (e.g., 20 bits) used for this audio data (AOTT\_AOB).

In order to achieve the second object, a playback apparatus according to the present invention has an audio management block (AMG) for managing audio contents (ATS) and their playback, and a video management block (VMG) for managing video contents (VTS) and their playback, the audio management block (AMG) plays back the audio contents (ATS) or video

contents (VTS) from a digital information medium  
(AV disc 10) containing audio management information  
(AMGI) for managing accesses to the audio contents  
(ATS) and video contents (VTS). This playback  
5 apparatus comprises: management information extraction  
means (30, 50 to 54) for extracting contents (ATT\_SRP  
in FIG. 20) of the audio management information (AMGI)  
from the digital information medium (10); audio  
contents extraction means (30, 50 to 54, 60) for  
10 extracting contents (audio cells and the like in  
FIG. 7) of the audio contents (ATS) on the basis of the  
contents (ATT\_SRP for AOTT in FIG. 20) of the audio  
management information (AMGI); and video contents  
extraction means (30, 50 to 54, 58) for extracting  
15 contents (video cells in FIG. 8) of the video contents  
(VTS) on the basis of other contents (ATT\_SRP for AVTT  
in FIG. 20) of the audio management information (AMGI).

The playback apparatus of the second object can  
play back a digital information medium (AV disc 10)  
20 which contains audio data (AOTT\_AOB) digitally  
converted by a predetermined sampling frequency (e.g.,  
192 kHz) selected from a plurality of different  
sampling frequencies (48 kHz, 96 kHz, 192 kHz, and the  
like) and a predetermined number of quantization bits  
25 (e.g., 20 bits) selected from a plurality of different  
numbers of quantization bits (16 bits, 20 bits, 24 bits,  
and the like), and attribute information (AOTT\_AOB\_ATR

in FIG. 25 included in ATSI in FIG. 24) indicating the predetermined sampling frequency (e.g., 192 kHz) and the predetermined number of quantization bits (e.g., 20 bits) used for this audio data (AOTT\_AOB). In this  
5 playback apparatus, the management information extraction means (50) detects the predetermined sampling frequency (e.g., 192 kHz) and the predetermined number of quantization bits (e.g., 20 bits) from the attribute information (AOTT\_AOB\_ATR), and the  
10 apparatus further comprises display means (4B) for displaying (the right end on FL display unit 4B in FIG. 30) the detected predetermined sampling frequency (e.g., 192 kHz) and predetermined number of quantization bits (e.g., 20 bits).

15 In order to achieve the third object, in a recording method according to the present invention, upon recording information on an information recording medium (10) having a volume space (28) including an audio zone (71) and video zone (72) located after the  
20 audio zone (71), audio management information (AMG) and audio contents (ATS) are recorded on the audio zone (71), and video management information (VMG) and video contents are recorded on the video zone (72).

25 In order to achieve the fourth object, in a playback method according to the present invention, upon playing back information from an information recording medium (10) on which an audio zone (71) which

records audio management information (AMG) and audio contents (ATS), and a video zone (72) which records video management information (VMG) and video contents (VTS) are recorded, the audio contents (ATS) or video contents (VTS) are accessed on the basis of the audio management information (AMG) to play back their contents, and the video contents are accessed on the basis of the video management information (VMG) to play back their contents.

#### 10 Brief Description of Drawings

FIG. 1 is a perspective view for explaining the structure of an optical disc which can be used as a recording medium of DVD audio;

15 FIG. 2 is a view for explaining the correspondence between a data recording area and recording tracks of data recorded there in the optical disc shown in FIG. 1;

20 FIG. 3 is a view for explaining the hierarchical structure of information recorded in a DVD audio zone of various kinds of information recorded on the optical disc shown in FIG. 2;

25 FIG. 4 is a view for explaining the hierarchical structure of information recorded in a DVD video zone of various kinds of information recorded on the optical disc shown in FIG. 2;

FIG. 5 is a view for explaining an example of video information (VTS\_C#2 or the like) which is

commonly accessed from both program chain information (ATS\_PGCI) in the DVD audio zone in FIG. 3 and program chain information (VTS\_PGCI) in the DVD video zone shown in FIG. 4;

5           FIG. 6 is a view for explaining an example of the data structure of the recording contents (AOTT\_AOBS) in the DVD audio zone shown in FIG. 3;

          FIG. 7 is a view for explaining another example of the data structure of the recording contents  
10 (AOTT\_AOBS) in the DVD audio zone shown in FIG. 3;

          FIG. 8 is a view for explaining an example of the data structure of the recording contents (VTSTT\_VOBS) in the DVD video zone shown in FIG. 4;

          FIG. 9 is a view for explaining an example of  
15 the data structure of the user accessible DVD audio recording contents recorded on one face of the optical disc shown in FIG. 1;

          FIG. 10 is a view for explaining an example of the directory structure of information (DVD audio and  
20 video data files) recorded on the optical disc shown in FIG. 1;

          FIG. 11 is a view for explaining another example of the directory structure of information (DVD audio and video data files) recorded on the optical disc  
25 shown in FIG. 1;

          FIG. 12 is a view for explaining an access from a directory on the audio contents side to files in

a directory on the video contents side in the directory structure shown in FIG. 10;

FIG. 13 is a view for explaining a link of a file in a directory on the audio contents side to that in  
5 a directory on the video contents side in the directory structure shown in FIG. 10;

FIG. 14 is a view for explaining an example of the file access process in FIG. 12 in a volume space shown in FIGS. 3 and 4;

10 FIG. 15 is a view for explaining another example of the file access process in FIG. 12 in the volume space shown in FIGS. 3 and 4;

FIG. 16 is a view for explaining still another example of the file access process in FIG. 12 in the  
15 volume space shown in FIGS. 3 and 4;

FIG. 17 is a view for explaining the recording contents of audio manager information (AMGI) in the DVD audio zone shown in FIG. 3;

FIG. 18 is a view for explaining the recording  
20 contents of an audio manager information management table (AMGI\_MAT) included in the audio manager information (AMGI) shown in FIG. 17;

FIG. 19 is a view for explaining the contents of an audio title search pointer table (ATT\_SRPT) included  
25 in the audio manager information (AMGI) shown in FIG. 17;

FIG. 20 is a view for explaining the contents of

an audio title search pointer (ATT\_SRP) included in the audio title search pointer table (ATT\_SRPT) shown in FIG. 19;

FIG. 21 is a view for explaining the contents of an audio only title search pointer table (AOTT\_SRPT) included in the audio manager information (AMGI) shown in FIG. 17;

FIG. 22 is a view for explaining the contents of an audio only title search pointer (AOTT\_SRP) included in the audio only title search pointer table (AOTT\_SRPT) shown in FIG. 21;

FIG. 23 is a view for explaining the relationship between an audio only title group (AOTT\_GR) accessed by the audio only search pointer (AOTT\_SRP) in the audio manager information (AMGI) shown in FIG. 17, and an audio title group (ATT\_GR) accessed by the audio title search pointer (ATT\_SRP) in that audio manager information (AMGI);

FIG. 24 is a view for explaining the recording contents of an audio title set (ATS) in the DVD audio zone shown in FIG. 3;

FIG. 25 is a view for explaining the recording contents of audio title set information management table (ATSI\_MAT) included in audio title set information (ATSI) shown in FIG. 24;

FIG. 26 is a view for explaining the contents of an audio title set program chain information table

(ATS\_PGCIT) included in the audio title set information (ATSI) shown in FIG. 24;

FIG. 27 is a view for explaining the contents of audio title set program information (ATS\_PGI) shown in  
5 FIG. 26;

FIG. 28 is a view for explaining the contents of audio title set cell playback information (ATS\_C\_PBI) shown in FIG. 26;

FIG. 29 is a block diagram showing an example of  
10 an apparatus for playing back information recorded in the audio zone shown in FIG. 3 or the video zone shown in FIG. 4 from the optical disc shown in FIG. 1;

FIG. 30 is a view showing an example of a front panel of the playback apparatus shown in FIG. 29;

15 FIG. 31 is a plan view of a double-layered optical disc according to an embodiment of the present invention when viewed from the read laser receiving face side;

FIG. 32 is a partial schematic sectional view of  
20 the double-layered optical disc shown in FIG. 31;

FIG. 33 is a partial schematic sectional view showing a modification of FIG. 32, in which two-substrate-joined optical disc OD has a single information recording layer;

25 FIG. 34 is a partial schematic sectional view showing another modification of FIG. 32, in which two-substrate-joined optical disc OD has a single

information recording layer;

FIG. 35 is a graph showing changes in allowable range of the thickness (ordinate) of a substrate to be joined as a function of the refractive index (abscissa) of a substrate material, when coherent light having a wavelength of 650 nm is used and a pair of substrates each having a single substrate/single recording layer structure are used; and

FIG. 36 is a graph showing changes in allowable range of the thickness (ordinate) of a substrate to be joined as a function of the refractive index (abscissa) of a substrate material, when coherent light having a wavelength of 650 nm is used and a pair of substrates each having a single substrate/dual recording layer structure are used.

#### Best Mode of Carrying Out the Invention

A digital information recording/playback system according to an embodiment of the present invention will be described hereinafter with reference to the accompanying drawings.

FIG. 1 is a perspective view for explaining the structure of an optical disc that can be used as a recording medium of DVD audio.

As shown in FIG. 1, this optical disc 10 has a structure obtained by adhering a pair of transparent substrates 14 each having recording layer 17 using adhesive layer 20. Each substrate 14 can be formed of

a 0.6-mm thick polycarbonate film, and adhesive layer 20 can consist of a very thin (e.g., 40 to 70  $\mu\text{m}$  thick) ultraviolet setting resin. When the pair of 0.6-mm thick substrates 14 are adhered to each other so that their recording layers 17 contact each other on the faces of adhesive layer 20, a 1.2-mm thick large-amount optical disc 10 is obtained.

Optical disc 10 has center hole 22, and clamp areas 24 used for clamping optical disc 10 upon its rotation are formed around center hole 22 on the two faces of the disc. Center hole 22 receives the spindle of a disc motor when disc 10 is loaded into a disc drive (not shown). Optical disc 10 is clamped at its clamp areas 24 by a disc clasper (not shown).

Optical disc 10 has information areas 25 that can record video data, audio data, and other information around clamp areas 24.

Each information area 25 has lead-out area 26 on its outer periphery side, and lead-in area 27 on its inner periphery side that contacts clamp area 24. The area between lead-out and lead-in areas 26 and 27 is defined as data recording area 28.

On recording layer (optical reflection layer) 17 of information area 25, a recording track is continuously formed in, e.g., a spiral pattern. The continuous track is divided into a plurality of physical sectors, which have serial numbers.

Various data are recorded on optical disc 10 using these sectors as recording units.

Data recording area 28 serves as an actual data recording area, and includes an audio data recording area, and DVD video data recording area. (In case of  
5 a pure audio disc, the DVD video data recording area may not be used.)

The DVD audio data recording area mainly records audio data as pit trains (physical shapes or phase  
10 states that bring about change in optical conditions) as recording/playback information. In some cases, the DVD audio data recording area may record still picture data. The audio data recorded on this DVD audio data recording area can contain silent data (not a silent  
15 part of music but data which does not produce any sound intentionally) in addition to normal music data.

On the other hand, the DVD video data recording area records, as recording/playback information, video data (main picture data) such as a movie or the like,  
20 sub-picture data such as superimposed dialogs, menus, and the like, and audio data such as words, effect sounds, and the like as similar pit trains.

When optical disc 10 is a double-sided recording RAM disc (or a rewritable disc; DVD-RW disc) in which  
25 each face has one recording layer, each recording layer 17 can be formed by three layers, i.e., by sandwiching a phase-change recording material layer (e.g.,

Ge<sub>2</sub>Sb<sub>2</sub>Te<sub>5</sub>) between two zinc sulfide·silicon oxide (ZnS·SiO<sub>2</sub>) mixture layers.

When optical disc 10 is a single-sided recording RAM disc in which each face has one recording layer, recording layer 17 on the side of read-out face 19 can be formed by three layers including the phase-change recording material layer. In this case, layer 17 on the side opposite to read-out face 19 need not be an information recording layer but may merely be a dummy layer.

When optical disc 10 is a one-side read type double-layered RAM/ROM disc, two recording layers 17 can comprise a single phase-change recording layer (on the side farther from read-out face 19; read/write), and a single semi-transparent metal reflection layer (on the side closer to read-out face 19; read-only).

When optical disc 10 is a write-once DVD-R, a polycarbonate substrate is used, gold can be used as a reflection layer (not shown), and an ultraviolet setting resin can be used as a protection layer (not shown). In this case, an organic dye is used in recording layer 17. As the organic dyes, cyanine, squarilium, chroconic, and triphenylmethane dyes, xanthene and quinone dyes (naphthoquinone, anthraquinone, and the like), metal complex dyes (phthalocyanine, porphyrin, dithiol complex, and the like), and so forth can be used.

Data can be written on such DVD-R disc using a semiconductor laser having a wavelength of 650 nm and an output of about 6 to 12 mW.

When optical disc 10 is a one-side read type double-layered ROM disc, two recording layers 17 can be comprised of a single metal reflection layer (on the side farther from read-out face 19) and a single semi-transparent reflection layer (on the side closer to read-out face 19).

In case of read-only DVD-ROM disc 10, pit trains are pre-formed by a stamper on substrate 14, and a reflection layer of, e.g., a metal, is formed on that face of substrate 14, which is formed with pit trains. The reflection layer is used as recording layer 17. In such DVD-ROM disc 10, no grooves serving as recording tracks are especially formed, and the pit trains formed on the face of substrate 14 serve as tracks.

In various types of optical discs 10 described above, read-only ROM information is recorded on recording layer 17 as an embossed pattern signal. By contrast, no such embossed pattern signal is formed on substrate 14 having read/write (or write-once) recording layer 17, and a continuous groove is formed instead. A phase-change recording layer is formed on such groove. In case of a read/write DVD-RAM disc, the phase-change recording layer in land portions is also used for information recording in addition to the

groove.

When optical disc 10 is of one-side read type (independently of one or two recording layers), substrate 14 on the rear side viewed from read-out face 19 need not always be transparent to the read/write laser beam used. In this case, a label may be printed on the entire face of substrate 14 on the rear side.

FIG. 2 is a view for explaining the correspondence between data recording area 28 and recording tracks of data recorded there on optical disc 10 shown in FIG. 1.

When disc 10 is a DVD-RAM (or DVD-RW), disc 10 itself is stored in a cartridge (not shown) to protect its delicate disc surface. When DVD-RAM disc 10 in the cartridge is inserted into the disc drive of a DVD player (FIGS. 29 and 30), disc 10 is pulled out from the cartridge, is clamped by the turntable of a spindle motor (not shown), and is rotated to face an optical head (not shown).

On the other hand, when disc 10 is a DVD-R or DVD-ROM, disc 10 itself is not stored in the cartridge, and bare disc 10 is directly set on the disc tray of a disc drive.

Recording layer 17 of information area 25 shown in FIG. 1 is formed with a continuous data recording track in a spiral pattern. The continuous track is divided into a plurality of logical sectors (minimum recording units) each having a given storage amount, as shown in

FIG. 2, and data are recorded with reference to these logical sectors. The recording amount per logical sector is determined to be 2,048 bytes (or 2 kbytes) which are equal to the data length of one pack.

5           Data recording area 28 is an actual data recording area, which records management data and audio data for DVD audio, and similarly records management data, main picture (video) data, sub-picture data, and audio data for DVD video.

10           When disc 10 shown in FIG. 2 is a DVD-RAM disc, its data recording area 28 can be divided into a plurality of ring-shaped (annular) recording areas (a plurality of recording zones), although not shown. The angular velocity upon rotation of the disc varies  
15           in units of recording zones. However, within each zone, a constant linear or angular velocity can be set. When disc 10 shown in FIG. 2 is a DVD-ROM disc, various data are recorded on the entire data recording area 28 at a constant linear velocity.

20           FIG. 3 is a view for explaining the hierarchical structure of information recorded in the DVD audio zone of various kinds of information recorded on optical disc 10 shown in FIG. 2.

          Data recording area 28 formed on optical disc 10  
25           shown in FIG. 2 has a structure, as shown in FIG. 3. The logical format of this structure is defined to comply with, e.g., the Universal Disc Format (UDF)

Bridge (a hybrid of UDF and ISO9660) as one of standard formats.

Data recording area 28 between lead-in area 27 and lead-out area 26 is assigned as a volume space. Volume space 28 can include a space for information of the volume and file structures (volume/file structure 70), a space for the application of the DVD format (DVD audio zone 71 and DVD video zone 72), and a space for an application other than that of this format (other recording area 73).

Volume space 28 is physically divided into a large number of sectors, and these physical sectors have serial numbers. The logical addresses of data recorded on this volume space (data recording area in FIG. 2) 28 mean logical sector numbers, as defined by the UDF Bridge. The logical sector size in this space is 2,048 bytes (or 2 kbytes) as in the physical sector size. The logical sector numbers are assigned serial numbers in ascending order of physical sector numbers.

Unlike the logical sectors, each physical sector is added with redundant information such as error correction information and the like. For this reason, the physical sector size does not strictly match the logical sector size.

As shown in FIG. 3, volume space 28 includes volume/file structure area 70, DVD audio zone 71, DVD video zone 72, and other recording area 73.

These areas (70 to 73) are split up on the boundaries of logical sectors in FIG. 2. Note that one logical sector is defined to be 2,048 bytes, and one logical block is also defined to be 2,048 bytes. Hence, one  
5 logical sector is defined equivalently with one logical block.

Volume/file structure area 70 corresponds to a management area defined by the UDF Bridge. Based on the description of this area 70, the contents of audio  
10 manager 711 are stored in an internal system memory of the DVD player (FIG. 29; to be described later).

DVD audio zone 71 consists of audio manager (AMG) 711 and one or more audio title sets (ATS#m) 712 (the maximum number m of audio title sets is 99).

15 AMG 711 is comprised of audio manager information (AMGI) file 7110, video object set (AMGM\_VOBS) file 7111 for an audio manager menu, and audio manager information backup (AMGI\_BUP) file 7112. Note that AMGM\_VOBS 7111 is an optional file, and is not present  
20 in some cases.

Each ATS 712 is comprised of audio title set information (ATSI) file 7120, audio object set (AOTT\_AOBS) file 7121 for an audio only title, and audio title set information backup (ATSI\_BUP) file 7123.  
25 Note that AOTT\_AOBS 7121 consists of one to nine files, which are optional files and are not present in some cases.

As will be described later with reference to FIG. 6, AOTT\_AOBS 7121 defines a set of one or more audio objects AOB. Each AOB defines a set of one or more audio title set cells (ATS\_C#). A set of one or more cells make up an audio title set program, and a set of one or more programs make up audio title set program chain PGC.

Considering one PGC as a single opera, a plurality of cells that form this PGC can be explained as music pieces or song parts of various scenes in that opera. The contents of this PGC (or the contents of each cell) are determined by the software provider who produces the contents recorded on disc 10. More specifically, the provider can program to play back cells that form AOTT\_AOBS 7121 using cell playback information ATS\_C\_PBI written in program chain information ATS\_PGCI in ATS as he or she intended. (ATS\_PGCI and ATS\_C\_PBI will be explained later with reference to FIGS. 24 to 28.)

Other recording area 73 can record information that can be used in video title sets VTS 72 mentioned above or other kinds of information that do not pertain to video title sets. This area 73 is not mandatory, and may be deleted if it is not used.

FIG. 4 is a view for explaining the hierarchical structure of information recorded in the DVD video zone of various kinds of information recorded on the optical

disc shown in FIG. 2. An explanation pertaining to DVD video zone 72 will be given below except for that already described with reference to FIG. 3.

Based on the description of volume/file structure area 70, the contents of video manager 721 are stored  
5 in the internal system memory of the DVD player (FIG. 29; to be described later).

DVD video zone 72 is comprised of video manager (VMG) 721 and one or more video title sets (VTS#n) 722  
10 (the maximum number n of video title sets is 99).

VMG 721 consists of video manager information (VMGI) file 7210, video object set (VMGM\_VOBS) file 7221 for a video manager menu, and video manager information backup (VMGI\_BUP) file 7212. Note that  
15 VMGM\_VOBS 7211 is an optional file, and is not present in some cases.

Each VTS 722 is comprised of video title set information (VTSI) file 7220, video object set (VTSM\_VOBS) file 7221 for a video title set menu,  
20 video object set (VTSTT\_VOBS) file 7222 for a video title set title, and video title set information backup (VTSI\_BUP) file 7223. Note that VTSM\_VOBS 7221 is an optional file, and is not present in some cases.

Each video title set VTS 72 stores video data  
25 (video pack to be described later) compressed by MPEG, audio data compressed by a predetermined format or uncompressed audio data (audio pack),

runlength-compressed sub-picture data (sub-picture pack  
to be described later; including bitmap data, each  
pixel of which is defined by a plurality of bits),  
and also information for playing back these data  
5 (navigation pack to be described later; including  
presentation control information and data search  
information).

As will be described later with the aid of FIG. 8,  
VTSTT\_VOBS 7222 defines a set of one or more video  
10 objects VOB. Each VOB defines a set of one or more  
video title set cells (VTS\_C#). A set of one or more  
cells make up a video title set program, and a set of  
one or more programs make up a video title set program  
chain.

15 Assuming that one PGC corresponds to one drama, a  
plurality of cells that make up this PGC can correspond  
to various scenes in that drama. The contents of  
the PGC (or those of cells) are determined by, e.g.,  
a software provider who produces the contents recorded  
20 on disc 10. More specifically, as in ATS\_PGCI  
described above with reference to FIG. 3, the provider  
can program to play back cells that form VTSTT\_VOBS  
7222 using cell playback information (not shown)  
written in program chain information VTS\_PGCI in VTS as  
25 he or she intended.

FIG. 5 is a view for explaining common accesses to  
specific video information (VTS\_C#2, VTS\_C#3, VTS\_C#5)

from program chain information ATS\_PGCI in the DVD audio zone in FIG. 3 and program chain information VTS\_PGCI in the DVD video zone in FIG. 4 (but by different methods). In other words, FIG. 5 exemplifies  
5 a case wherein single video object VOB is referred to by different methods from playback units on both the audio and video sides.

More specifically, upon video playback from the video title set side, cells VTS\_C#1 to VTS\_C#6 in VOB  
10 are played back in turn in accordance with cell playback information (not shown) in VTS\_PGCI.

On the other hand, upon video playback (or still playback) from the audio title set side, cells VTS\_C#2, VTS\_C#3, and VTS\_C#5 in VOB are selectively played back  
15 in accordance with cell playback information (FIG. 28) in ATS\_PGCI.

In this case, since ATS and VTS need not independently have identical cell data (VTS\_C#2, VTS\_C#3, and VTS\_C#5) in single disc 10, the limited  
20 resource of disc 10 can be effectively used.

FIG. 6 shows an example of the data structure of the recording contents (AOTT\_AOBS) in the DVD audio zone shown in FIG. 3.

AOTT\_AOBS 7121 described above with the aid of  
25 FIG. 3 defines a set of one or more audio objects AOTT\_AOB#, as shown in FIG. 6. A set of one or more cells ATS\_C# form a program, and a set of one or more

programs form program chain PGC. This PGC forms a logical unit indicating the entire or partial audio title.

In the example shown in FIG. 6, each audio cell  
5   ATS\_C# is comprised of a set of audio packs A\_PCK each having a 2,048-byte size. These packs serve as minimum units upon data transfer. On the other hand, the minimum unit for logical processing is a cell, and the logical processing is done in units of cells.

10         FIG. 7 shows another example of the data structure of the recording contents (AOTT\_AOBS) in the DVD audio zone shown in FIG. 3. In the example shown in FIG. 7, the cell and pack formats are different from those in FIG. 6.

15         More specifically, audio object AOTT\_AOB#1 shown in FIG. 7 contains picture cell ATS\_C#1, silent cell ATS\_C#2, audio cell ATS\_C#3, and the like. The next AOTT\_AOB#2 may contain audio cells ATS\_C alone, although not shown. The audio object mainly contains  
20   audio cells, but a picture cell and/or silent cell are/is appended appropriately.

       Picture cell ATS\_C#1 may consist of one or more still picture packs SPCT\_PCK, and silent cell ATS\_C#2 may consist of one or more silent audio packs A\_PCK.  
25   The playback time of the silent cell is set at about 0.5 sec or more. Audio cell ATS\_C#3 consists of audio packs A\_PCK and also appropriately contains real time

information packs RTI\_PCK having real time information.

Upon data transfer of still picture pack SPCT\_PCK during playback of a DVD audio player, sound is interrupted for a short period of time (about 0.5 sec to 0.6 sec) during transfer. This sound interruption is called an audio gap. Since it is inconvenient if an audio gap is produced in the middle of music playback, still picture pack SPCT\_PCK is normally transferred before the beginning of album playback in FIG. 9, before the beginning of playback of a specific group, or before the beginning of a specific track.

Once still picture pack SPCT\_PCK has been transferred inside the DVD audio player, a still picture corresponding to the contents of this SPCT\_PCK is held in a picture memory in the player. The still picture in this memory can be continuously played back during playback of the contents (music or the like) of audio packs A\_PCK (the still picture can be cleared from the monitor any time the user desires).

FIG. 8 shows an example of the data structure of the recording contents (VTSTT\_VOBS) in the DVD video zone shown in FIG. 4.

VTSTT\_VOBS described above using FIG. 4 defines a set of one or more video objects VOB#, as shown in FIG. 8. Each VOB defines a set of one or more cells VTS\_C#. Each VTS\_C defines a set of one or more video object units VOB#. A set of one or more cells VTS\_C#

make up a program, and a set of one or more programs make up program chain PGC. This PGC forms a logical unit indicating the entire or partial audio title.

As shown in FIG. 8, each VOB is constituted as a set (pack sequence) of video packs (MPEG-compressed moving picture data), sub-picture packs (runlength-compressed bitmap data), and audio packs (non-compressed linear PCM audio data or compressed multichannel audio data) to have a navigation pack at the beginning of the sequence. That is, video object unit VOB is defined as a set of all packs recorded from a certain navigation pack to a pack immediately before the next navigation pack. This navigation pack is built in each video object unit VOB to realize angle change (non-seamless angle change playback and seamless angle change playback).

Each of these packs serves as a minimum unit for data transfer as in FIG. 6 or 7. The minimum unit for logical processing is a cell, and logical processing is done in units of cells.

The playback time of VOB corresponds to that of video data made up of one or more picture groups (groups of pictures; to be abbreviated as GOPs), and is set to fall within the range from 0.4 sec to 1.2 sec. One GOP is screen data which normally has a playback time of about 0.5 sec in the MPEG format, and is compressed to play back approximately 15 pictures

during this interval.

When VOBU includes video data, a video datastream is formed by arranging GOPs (complying with MPEG) each consisting of video packs, sub-picture packs, and audio packs. However, independently of the number of GOPs, VOBU is defined with reference to the playback time of GOPs, and a navigation pack is always set at the beginning of VOBU.

Upon playback for DVD video, even playback data consisting of audio data and/or sub-picture data alone is formed using VOBU as one unit. For example, assume that VOBU is formed by audio packs alone to have a navigation pack at its beginning. In this case, the audio packs to be played back in the playback time (0.4 sec to 1.2 sec) of VOBU to which the audio data belong are stored in that VOBU as in VOB of video data.

As shown in FIG. 8, VTSTT\_VOBS is defined as a set of one or more VOBs, and VOBs in this VOBS are used for the same purpose.

VOBS for menus normally consists of one VOB, which stores a plurality of menu screen display data. By contrast, VOBS for a title set normally consists of a plurality of VOBs.

Taking a concert video title of a certain rock band as an example, VOBs that form video object set VTSTT\_VOBS for a title set correspond to picture data of the performance of that band. In this case, by

designating given VOB, for example, the third tune in the concert of the band can be played back.

VOB that forms video object set VTSM\_VOBS for menus stores menu data of all the tunes performed in the concert of the band, and a specific tune, e.g., an encore, can be played back according to the menu display.

Note that one VOB can form one VOBS in a normal video program. In this case, a single video stream comes to an end in one VOB.

On the other hand, in case of a collection of animations having a plurality of stories or an omnibus movie, a plurality of video streams (a plurality of video chains PGC) can be set in single VOB in correspondence with the respective stories. In this case, the individual video streams are stored in corresponding VOBS. An audio stream and sub-picture stream pertaining to each video stream end in corresponding VOB.

Video objects VOB are assigned identification numbers (#i;  $i = 0$  to  $i$ ), and that VOB can be specified by the identification number. VOB consists of one or more cells. A normal video stream consists of a plurality of cells, but a video stream for menus often consists of single cell. The cells are assigned identification numbers (#j;  $j = 0$  to  $j$ ) as in VOBS.

FIG. 9 shows the recording contents of user

accessible DVD audio zone 71, i.e., an example of the data structure recorded on one side (single- or double-layered) of the optical disc in FIG. 1.

In DVD audio, the hierarchical structure defined  
5 by an album, groups, tracks, and indices is prepared as the management structure for the recording contents viewed from the software production side.

The album corresponds to one side of DVD audio disc 10, and for example, "Vol. 1 of works of  
10 Beethoven" can be assigned to this album. In such case, this album may be made up of group #1 of Symphony No. 1 to group #9 of Symphony No. 9.

Each group (e.g., group #1) is made up of tracks #1 to #4 corresponding to the first to fourth movements  
15 of the corresponding symphony (Symphony No. 1). Furthermore, each track is comprised of indices #1 to #i obtained by dividing the contents of the track into i pieces.

When the user plays back DVD audio disc 10  
20 produced with the hierarchical structure shown in FIG. 9, the user sets that disc 10 on the DVD audio player (FIGS. 29 and 30), and then can select group #1 and track #1 by operating a remote controller (not shown).

25 After this selection, when the user presses the playback button of the remote controller, the DVD audio player starts playback from the beginning of the first

movement of Symphony No. 1 of Beethoven. Furthermore, when the user designates a specific index using the remote controller, the designated index part is reached by search, and playback restarts from that part.

5 (The first index part of the first track of the first group in that album can be played back as a default without any user's designation.)

Note that the user can recognize a title (e.g., a specific movie title or the like) in case of playback  
10 of a DVD video disc. However, in case of a DVD audio disc, the user cannot see the "title". The user can only see "album", "group", "track", and "index" shown in FIG. 9.

FIG. 10 shows the directory structure of  
15 information (DVD audio and video data files) recorded on the optical disc shown in FIG. 1. FIG. 10 shows an example of the file directory structure defined by the DVD file format.

As in the hierarchical file structure used by  
20 a versatile operating system of a computer, the subdirectory of video title set VTS and that of audio title set ATS, the user-defined directory, and the like are located in succession under the root directory.

Various video files (files VMGI, VMGM, VTSI, VTSM,  
25 VTS, and the like; see FIG. 4) are located in the subdirectory of video title set VTS to manage the individual files systematically.

Also, various audio files (files AMGI, ATSI, ATS, and the like; see FIG. 3) are located in the subdirectory of audio title set ATS to manage the individual files systematically.

5           The user can access a specific file (e.g., specific VTS or ATS) by designating the path from the root directory to that file.

          Upon playing back a DVD video disc created according to the DVD video format, a DVD video player  
10           manufactured according to the DVD video format reads management information (VMG) located in the video title set VTS directory beneath the root directory first, and plays back video contents in accordance with that information. However, VMG can only play back the video  
15           contents (VTS) recorded in the VTS directory.

          On the other hand, upon playing back a DVD audio disc created according to the DVD audio format, a DVD audio player (or a DVD-Video/DVD-Audio compatible  
20           player) manufactured in accordance with the DVD audio format reads management information (AMG) located in the audio title set ATS directory under the root directory, and plays back audio contents in accordance with that information. In this case, AMG can play back not only the audio contents (ATS) recorded in the ATS  
25           directory but also the video contents (VTS) in the VTS directory (this mechanism will be explained later with reference to FIG. 12 and the subsequent figures).

FIG. 11 shows another example of the directory structure of information (DVD audio and video data files) recorded on the optical disc shown in FIG. 1.

In the example shown in FIG. 10, both the VTS and  
5 ATS directories are located on the same layer level under the root directory. On the other hand, in the example shown in FIG. 11, the ATS directory (child directory) is located in a layer under the root  
10 directory (parent directory), and the VTS directory (grandchild directory) is located in a layer under the ATS directory.

FIG. 12 is a view for explaining an access from the directory on the audio contents side to a file in the directory on the video contents side in the  
15 directory structure shown in FIG. 10.

More specifically, in the hierarchical management structure for managing data files recorded on AV disc  
20 10, the video title set directory (child directory) and audio title set directory (child directory) are located under the root directory (parent directory).

The video title set (VTS) directory manages files for the video contents recorded on disc 10, and contains a file of video manager VMG and one or more files (logical units of the video contents) of video  
25 title sets VTS (see FIG. 4).

The audio title set (ATS) directory manages files for the audio contents recorded on disc 10, and

contains a file of audio manager AMG and one or more files (logical units of the audio contents) of audio title sets ATS (see FIG. 3).

VMG in the VTS directory manages VTS alone, and  
5 can only access VTS in the VTS directory.

On the other hand, AMG in the ATS directory mainly manages ATS, but can access not only ATS in the ATS directory but also VTS in the VTS directory.

AMG contains audio manager information AMGI  
10 (FIG. 17), AMGI contains audio title search pointer table ATT\_SRPT (FIG. 17), and ATT\_SRPT contains audio only title (AOTT) search pointer ATT\_SRP and audio video (AVTT) search pointer ATT\_SRP (FIG. 20) (their contents will be explained in detail later with  
15 reference to FIGS. 17 to 20).

More specifically, AMG in the ATS directory can access audio title sets ATS#1, ATS#2, ... in the ATS directory by AOTT search pointer ATT\_SRP, and can also access video title sets VTS#1, VTS#2, ... in the VTS  
20 directory by AVTT search pointer ATT\_SRP. In this way, a certain object (e.g., VTS#1) can be shared by both the video and audio contents. This is one of important characteristic features of the "object sharing system" of the present invention.

25 FIG. 13 is a view for explaining a link from a file in the directory on the audio contents side to that in the directory on the video contents side in the

directory structure shown in FIG. 10. FIG. 13 can be considered as a modification of FIG. 12.

More specifically, in the example shown in FIG. 12, since audio manager AMG is capable of accessing both audio title sets ATS and video title sets VTS,  
5 a certain VTS can be shared by the video and audio contents.

On the other hand, in the example shown in FIG. 13, information (e.g., a pointer indicating the address of  
10 a predetermined portion of VTS#1) for linking to a certain video title set (VTS#1 in this case) is written in a certain audio set (ATS#1 in this case). With this information, audio data in, e.g., VTS#1 can be shared by the video and audio contents.

15 FIG. 14 shows the data structure to explain an example of the file access process in FIG. 12 in the volume space shown in FIGS. 3 and 4. The data structure shown in FIG. 14 corresponds to the directory structure shown in FIG. 12.

20 Referring to FIG. 14, the hatched portions exemplify contents shared by the video contents (or video volume) and audio contents (or audio volume).

The principle of the data structure shown in FIG. 14 is to independently record the recording area  
25 (VMG + VTS) for the video contents and the recording area (AMG + ATS) for the audio contents in volume space 28, and to allow AMG to manage the video contents which

are used not only for video but also commonly for audio.

For example, in FIG. 14, video title set VTS#1 managed by VMG can access a portion (cell) in video object sets VOBS#1, while audio title set ATS#1 managed by AMG can access another portion (cell) in VOBS#1. In this example, some cells (see FIG. 8) that make up video object set VOBS#1 of VTS#1 are shared by the video and audio contents.

In the data structure shown in FIG. 14, DVD audio zone 71 is located on the side of smaller addresses (closer to lead-in area 27 in FIG. 3), and DVD video zone 72 is located on the side of larger addresses (closer to lead-out area 26 in FIG. 3). In this case, AMG can always use addresses that change in the + direction (see arrows a and b) upon accessing both ATS and VTS, and need not use addresses in the - direction, resulting in easy construction of the playback system.

FIG. 15 shows the data structure to explain another example of the file access process in FIG. 12 in the volume space shown in FIGS. 3 and 4. FIG. 15 can be considered as a modification of FIG. 14.

In FIG. 14, since the DVD audio zone 71 is located on the side of smaller addresses, and DVD video zone 72 is located on the side of larger addresses, the addresses in the - direction need not be used, as described above.

On the other hand, in FIG. 15, DVD video zone 72

is located on the side of smaller addresses (closer to lead-in area 27 in FIG. 3), and DVD audio zone 71 is located on the side of larger addresses (closer to lead-out area 26 in FIG. 3). In such case, AMG uses the address in the + direction to access ATS, and uses the address in the - direction to access VTS. That is, addressing upon accessing a desired object (cells in ATS or VTS) is cumbersome, and it is inappropriate to use such address allocation in home-use DVD audio players that require low manufacturing cost.

However, when a personal computer having a DVD drive is used as a DVD audio player with the help of software, the cost problem can be avoided even when the data structure shown in FIG. 15 is used. That is, an operating system (or control software) on the personal computer, which has interpreted the data structure shown in FIG. 15, can re-map the addresses onto its own memory and can apparently convert the data structure physically having the address allocation shown in FIG. 15 into that shown in FIG. 14. In this way, an MPU or CPU of that personal computer allows AMG to access both ATS and VTS by designating addresses in the + direction alone as in FIG. 14.

FIG. 16 shows the data structure to explain still another example of the file access process in FIG. 12 in the volume space shown in FIGS. 3 and 4. FIG. 16 can also be considered as a modification of FIG. 14.

In FIG. 14, since the DVD audio zone 71 is located on the side of smaller addresses, and DVD video zone 72 is located on the side of larger addresses, the addresses in the - direction need not be used, as  
5 described above.

By contrast, in the data structure shown in FIG. 16, AMG in DVD audio zone 71 is located on the side of smaller addresses (closer to lead-in area 27 in FIG. 3), and VMG in DVD video zone 72 is located on the  
10 side of larger addresses (closer to lead-out area 26 in FIG. 3) than AMG. In this case, AMG can always use addresses that change in the + direction to access both ATS and VTS, and need not use addresses in the -  
direction. For this reason, the playback system can be  
15 easily constructed as in FIG. 14.

However, since the data structure shown in FIG. 16 is a "nested" structure, i.e., VTS#1 and the like are located in ATS#1, VMG in FIG. 4 cannot recognize that VTS in ATS is present in DVD video zone 72. In such  
20 case, VMG can handle that VTS in ATS as one in other recording area 73.

The data structure shown in FIG. 16 can be used when AMG can access not only ATS but also VTS using other recording area 73.

25 The three different examples shown in FIGS. 14 to 16 have been described as those for the data structure in which "AMG can access both ATS and VTS". The most

preferred data structure is that shown in FIG. 14, since a desired shared object can be accessed by only designating an address in the + direction without re-mapping the addresses.

5           FIG. 17 is a view for explaining the recording contents of audio manager information AMGI in the DVD audio zone shown in FIG. 3.

DVD audio zone 71 can handle two different types of contents, i.e., audio only title AOTT and audio  
10 title with video (or audio-video title) AVTT.

AOTT is a title in audio disc (A disc 10), has no video part, and is defined by ATS recorded underneath the audio title set directory. On the other hand, AVTT is a title in audio disc (AV disc) 10, has video part,  
15 and is defined by VTS recorded underneath the video title set directory. The general name of AOTT and AVTT is defined as ATT (audio title).

DVD audio zone 71 on which the ATT data are recorded is made up of AMG 711 and one or more (a  
20 maximum of 99) audio title sets (ATS#1 to ATS#m) 712.

AMG 711 consists of audio manager information AMGI file 7110, video object set AMGM\_VOBS file (optional file) 7111 for audio manager menus, and audio manager information backup AMGI\_BUP file 7112.

25           AMGI file 7110 contains audio manager information management table AMGI\_MAT, audio title search pointer table ATT\_SRPT, audio only title search pointer table

AOTT\_SRPT, audio manager menu program chain information unit table AMGM\_PGCI\_UT, and audio text data manager ATXTDT\_MG.

5 More specifically, AMG has two pieces of search information ATT\_SRPT and AOTT\_SRPT. ATT\_SRPT is a table that describes search information for both AOTT and AVTT, and AOTT\_SRPT is a table that describes search information for AOTT alone.

10 The reason why the search information is prepared not for AVTT and AOTT but for ATT (the general name of AOTT and AVTT) (ATT\_SRPT in FIG. 20; to be described later) and AOTT (AOTT\_SRPT in FIG. 22; to be described later) is to facilitate the playback methods of various DVD players.

15 FIG. 18 shows the recording contents of audio manager information management table AMGI\_MAT contained in audio manager information AMGI shown in FIG. 17.

20 More specifically, audio manager information management table AMGI\_MAT includes: an audio manager identifier (AMG\_ID); the end address (AMG\_EA) of the audio manager; the end address (AMGI\_EA) of the audio manager information; the version number (VERN) of the format used by optical disc (DVD audio disc) 10 of interest; a volume set identifier (VLMS\_ID); auto play information (AP\_INF) indicating the playback state  
25 after the disc is loaded into the player; the start address (ASVS\_SA) of audio still video set ASVS, which

address is expressed by the number of relative blocks from the first logical block of AMG; the number (TS\_Ns) of title sets; an identifier (PVR\_ID) of the provider (i.e., the producer and distributor of software);

5 the end address (AMGI\_MAT\_EA) of the audio manager information management table; the start address (AMGM\_VOBS\_SA) of an audio manager menu video object set; the start address (ATT\_SRPT\_SA) of the audio title search pointer table; the start address (AOTT\_SRPT\_SA)

10 of the audio only title search pointer table; the start address (AMGM\_PGCI\_UT\_SA) of the audio manager menu program chain information unit table; the start address (ATXTDT\_MG\_SA) of the audio text data manager; a video attribute (AMGM\_V\_ATR) for the audio manager menu video

15 object set; the number (AMGM\_SPST\_Ns) of sub-picture streams for audio manager menus; a sub-picture attribute (AMGM\_SPST\_ATR) for the audio manager menu video object set; the number (AMGM\_AST\_Ns) of audio streams of audio manager menus; an audio attribute

20 (AMGM\_AST\_ATR) for the audio manager menu video object set; and other reserved areas.

In start address AMGM\_VOBS\_SA of the audio manager menu video object set, the start address of AMGM\_VOBS is written as the number of relative blocks from the

25 first logical block of AMG. If AMGM\_VOBS does not exist, "00000000h" is written in this AMGM\_VOBS\_SA.

In start address ATT\_SRPT\_SA, the start address of

ATT\_SRPT is written as the number of relative blocks from the first logical block of AMGI.

In start address AOTT\_SRPT\_SA, the start address of AOTT\_SRPT is written as the number of relative  
5 blocks from the first logical block of AMGI.

ATT\_SRPT\_SA or AOTT\_SRPT\_SA written in AMGI\_MAT in FIG. 18 can indicate the recording location of audio title search pointer table ATT\_SRPT or audio only title search pointer table AOTT\_SRPT in disc 10.

10 FIG. 19 is a view for explaining the contents of audio title search pointer table ATT\_SRPT contained in audio manager information AMGI shown in FIG. 17. AMGI has two different search pointer tables ATT\_SRPT and AOTT\_SRPT, and FIG. 19 shows search pointer ATT\_SRP  
15 that can access both AOTT and AVTT.

More specifically, ATT\_SRPT contained in AMGI includes audio title search pointer table information ATT\_SRPTI and one or more audio title search pointers ATT\_SRP (ATT\_SRP#1 to ATT\_SRP#n). ATT\_SRPTI contains  
20 the number of audio title search pointers, and the end address of ATT\_SRPT.

FIG. 20 is a view for explaining the contents of each audio title search pointer (ATT\_SRP#n in this case) included in audio title search pointer table  
25 ATT\_SRPT shown in FIG. 19.

The DVD audio format handle use not only sound data but also picture data, and AMG has two pieces of

search information ATT\_SRPT and AOTT\_SRPT. ATT\_SRPT shown in FIG. 20 is a table that describes search information for both AOTT and AVTT.

Referring to FIG. 20, audio only title search pointer AOTT\_SRP includes category ATT\_CAT of audio title ATT, number ATT\_PG\_Ns of programs in one audio title ATT, total playback time ATT\_PB\_TM of audio title ATT, audio title set ATS number ATSN, audio title set ATS title number ATS\_TTN, and start address ATS\_SA of audio title set ATS.

Audio video title search pointer AVTT\_SRP includes category ATT\_CAT of audio title ATT, number ATT\_PG\_Ns of programs in one ATT, number AGL\_Ns of angles included in video, total playback time ATT\_PB\_TM of audio title ATT, video title set VTS number VTSN, video title set VTS title number VTS\_TTN, and start address VTS\_SA of video title set VTS.

FIG. 21 is a view for explaining the contents of audio only title search pointer table AOTT\_SRPT contained in audio manager information AMGI shown in FIG. 17. AMGI has two different search pointer tables ATT\_SRPT and AOTT\_SRPT, and FIG. 21 shows search pointer AOTT\_SRP that can access only AOTT.

More specifically, AOTT\_SRPT contained in AMGI includes audio only title search pointer table information AOTT\_SRPTI, and one or more audio only title search pointers AOTT\_SRP (AOTT\_SRP#1 to

AOTT\_SRP#m). AOTT\_SRPTI includes number AOTT\_SRP\_Ns of audio only search pointers, and end address AOTT\_SRPT\_EA of AOTT\_SRPT.

FIG. 22 is a view for explaining the contents of one audio only search pointer (AOTT\_SRP#m in this case) included in audio only title search pointer table AOTT\_SRPT shown in FIG. 21.

The DVD audio format handle use not only sound data but also picture data, and AMG has two pieces of search information ATT\_SRPT and AOTT\_SRPT. AOTT\_SRPT shown in FIG. 22 is a table that describes search information for only AOTT.

More specifically, in FIG. 22, audio only title search pointer AOTT\_SRP includes category ATT\_CAT of audio title ATT, number AOTT\_PG\_Ns of programs in one audio only title AOTT, total playback time AOTT\_PB\_TM of audio only title AOTT, audio title set ATS number ATSN, audio title set ATS title number ATS\_TTN, and start address ATS\_SA of audio title set ATS.

In control information of a playback title defined in audio manager AMG, title group TT\_GR can be designated.

Title group TT\_GR is a set of one or more audio titles ATT, and is defined as a unit for guaranteeing continuous playback of an ATT group. On the user side, each audio title ATT corresponds to a "tune", and title group TT\_GR corresponds to an "album" as a set of tunes

(see FIG. 9). On a record or CD, when playback starts from the first or middle tune of the album, that album can be continuously played back to its end. Likewise, when playback starts from the first or middle ATT in  
5 TT\_GR, playback continues to the end of this TT\_GR.

As title group TT\_GR, the following two groups can be defined.

<A1> Audio title group (ATT\_GR); this ATT\_GR is title group TT\_GR consisting of audio titles ATT  
10 defined in audio title search pointer table ATT\_SRPT.

<A2> Audio only title group (AOTT\_GR); this AOTT\_GR is title group TT\_GR consisting of audio only titles AOTT defined in audio only search pointer table  
AOTT\_SRPT.

15 Audio title group ATT\_GR is used for a player which can play back picture and audio data complying with the audio format (i.e., a player which can play back both AOTT and AVTT), and audio only title group AOTT\_GR is used for a player which can play back only  
20 audio data complying with the audio format (i.e., a player which can play back only AOTT).

Audio title ATT has the following three variations.

<B1> ATT has only AOTT.

<B2> ATT has only AVTT.

25 <B3> ATT has both AOTT and AVTT (in this case, ATT has AVTT and AOTT corresponding to different versions (with and without a picture) of an identical

tune).

In case of <B1>, search information for AOTT is described in both ATT\_SRPT and AOTT\_SRPT (see FIGS. 20 and 22).

5 In case of <B2>, search information for AVTT is described in only ATT\_SRPT (see FIG. 20).

In case of <B3>, search information for AOTT is described in only AOTT\_SRPT, and that for AVTT is described in only ATT\_SRPT (see FIG. 20).

10 FIG. 23 exemplifies the relationship among <B1> to <B3> above. That is, FIG. 23 exemplifies the relationship between audio only title group AOTT\_GR accessed by audio only title search pointer AOTT\_SRP in audio manager information AMGI shown in FIG. 17, and  
15 audio title group ATT\_GR accessed by audio title search pointer ATT\_SRP in that audio manager information AMGI. In other words, FIG. 23 shows an example of the relationship between ATT\_SRPT and AOTT\_SRPT.

Referring to FIG. 23, audio titles ATT#1 and ATT#9  
20 are made up of only audio video titles AVTT, ATT#2 and ATT#3 of audio video titles AVTT and audio only titles AOTT, and ATT#4, ATT#5, ATT#7, and ATT#8 of only audio only titles AOTT.

In the example shown in FIG. 23, nine audio titles  
25 ATT are used, are classified into four groups (GR#1 to GR#4) to form audio title groups ATT\_GR, and are classified into two groups (GR#1 and GR#2) to form

audio only title groups AOTT\_GR.

In this example, audio titles ATT#1 and ATT#9 consist of AVTT alone, and do not include any AOTT. Hence, ATT#1 and ATT#9 do not exist as audio only title group AOTT\_GR.

For this reason, the number (four in this example) of audio title groups ATT\_GR does not generally match that (two in this example) of audio only title groups AOTT\_GR.

It is necessary to maintain consistency of title group TT\_GR upon playing back an ATT group between a player which can play back picture and audio data complying with the audio format (i.e., a player which can play back both AOTT and AVTT), and a player which can play back only audio data complying with the audio format (i.e., a player which can play back only AOTT).

More specifically, even though corresponding ATT\_GR and AOTT\_GR have different GR numbers, they should include identical ATTs and have the same order of ATTs in TT\_GR. Otherwise, the user is confused. Of course, in this case, ATTs (ATT#1 and ATT#9) which consist of AVTT alone but include no AOTT are excluded.

To meet this "demand", "ATT not defined as AOTT" and "ATT defined as AOTT" are prevented from being present in single ATT\_GR. In this way, the consistency in TT\_GR can be maintained for ATTs included in both ATT\_GR and AOTT\_GR.

In the example shown in FIG. 23, ATT\_GR#2 and AOTT\_GR#1, and ATT\_GR#3 and AOTT\_GR#2 are respectively made up of identical ATTs, and have the same orders of ATT in TT\_GR.

5           FIG. 24 is a view for explaining the recording contents of an audio title set (ATS) in the DVD audio zone shown in FIG. 3.

          Audio title set ATS is made up of audio title set information ATSI, audio only title set audio object set  
10 AOTT\_AOBS, and audio title set information backup ATSI\_BUP.

          Audio title set information ATSI includes audio title set management table ATSI\_MAT, and audio title set program chain information table ATS\_PGCIT.

15           Audio title set program chain information table ATS\_PGCIT includes audio title set program chain information table information ATSI\_PGCITI, audio title set program chain information search pointer  
20 ATS\_PGCI\_SRP, and one or more pieces of audio title set program chain information ATS\_PGCI.

          FIG. 25 shows the recording contents of audio title set information management table ATSI\_MAT shown in FIG. 24.

          More specifically, this audio title set information management table ATSI\_MAT includes: an audio title  
25 set identifier (ATSI\_ID); the end address (ATS\_EA) of an audio title set; the end address (ATSI\_EA) of audio

title set information; the version number (VERN) of the audio format used; the end address (ATSI\_MAT\_EA) of the audio title set information management table; the start address (VTS\_SA) of audio only title AOTT video title set VTS; the start address (AOTT\_AOBS\_SA) of an audio only title audio object set or the start address (AOTT\_VOBS\_SA) of an audio only title video object set; the start address (ATS\_PGCIT\_SA) of the audio title set program chain information table; attributes (AOTT\_AOB\_ATR) #0 to #7 of an audio only title audio object set or attributes (AOTT\_VOB\_ATR) #0 to #7 of an audio only title video object set; coefficients (ATS\_DM\_COEFT) #0 to #15 to mix down audio data; and other reserved areas.

15           In start address VTS\_SA of VTS for AOTT, the start address of VTS including VTSTT\_VOBS (FIG. 8) used for AOTT is written when ATS has no AOTT\_AOBS. On the other hand, when ATS has AOTT\_AOBS, "00000000h" is written in VTS\_SA.

20           In AOTT\_AOBS\_SA, the start address of AOTT\_AOBS is written as the number of relative logical blocks from the first logical block of ATS when ATS has AOTT\_AOBS. On the other hand, when ATS has no AOTT\_AOBS, the start address of VTSTT\_VOBS is written as the number of relative logical blocks from the first logical block of VTS that includes VTSTT\_VOBS used for ATS.

25           In ATS\_PGCIT\_SA, the start address of ATS\_PGCIT is

written as the number of relative logical blocks from the first logical block of ATSI.

Eight attributes #0 to #7 are prepared for AOTT\_AOB\_ATR or AOTT\_VOB\_ATR. When ATS has AOTT\_AOBS, the attribute of AOTT\_AOB written in ATS is written in AOTT\_AOBS\_ATR. On the other hand, when ATS has no AOTT\_AOBS, the attribute of an audio stream in VOB used for AOTT\_VOB in ATS is written in AOTT\_VOB\_ATR. In AOTT\_AOB\_ATR or AOTT\_VOB\_ATR, the sampling frequency (44 to 192 kHz) used and the number of quantization bits (16 to 24 bits) are written.

ATS\_DM\_COEFT indicates a coefficient upon mixing down audio data having multichannel outputs (5.1-channel outputs) like in AC-3, DTS, or the like to 2-channel outputs, and is used in only one or more AOTT\_AOBS recorded in ATS. When ATS has no AOTT\_AOBS, "0h" is written in all the bits of 16 coefficients ATS\_DM\_COEFT (#0 to #15). Areas for these 16 coefficients ATS\_DM\_COEFT (#0 to #15) are steadily assured.

Each ATS\_SPCT\_ATR has a 16-bit configuration: 2 bits (bits b15 and b14) on the MSB side represent a video compression mode (MPEG2 or the like); the next 2 bits (bits b13 and b12) a TV system (NTSC, PAL, SECAM, or the like); the next 2 bits (bits b11 and b10) the aspect ratio (4 : 3, 16 : 9, or the like) of a picture; and the next 2 bits (bits b9 and b8) a display mode

(4 : 3 display, 16 : 9 display, letter box display,  
or the like on a TV monitor having a 4 : 3 size).  
The next 2 bits (bits b7 and b6) are reserved bits for  
the future. The next 3 bits (bits b5 to b3) represent  
5 the resolution (720 lines in the horizontal direction ×  
480 lines in the vertical direction in the NTSC system),  
720 lines in the horizontal direction × 576 lines in  
the vertical direction in the PAL system, or the like)  
of a still picture. The last 3 bits (bits b2 to b0) on  
10 the LSB side are reserved bits for the future.

FIG. 26 is a view for explaining the contents  
of audio title set program chain information table  
ATS\_PGCIT included in audio title set information ATSI  
shown in FIG. 24 (the recording location of this  
15 ATS\_PGCIT is written in ATS\_PGCIT\_SA in ATSI\_MAT shown  
in FIG. 25).

This ATS\_PGCIT contains audio title set program  
chain information table information ATS\_PGCITI, audio  
title set program chain information search pointer  
20 ATS\_PGCI\_SRP, and audio title set program chain  
information ATS\_PGCI, as described above.

ATS\_PGCI\_SRP includes one or more audio title  
set program chain information search pointers  
(ATS\_PGCI\_SRP#1 to ATS\_PGCI\_SRP#j), and ATS\_PGCI  
25 includes the same number of pieces of audio title set  
program chain information (ATS\_PGCI#1 to ATS\_PGCI#j) as  
that of pointers ATS\_PGCI\_SRP.

Each ATS\_PGCI serves as navigation data for controlling playback of audio title set program chain ATS\_PGC.

Note that ATS\_PGC is a unit for defining audio only title AOTT, and is made up of ATS\_PGCI and one or more cells (those in AOTT\_AOBS or those in AOTT\_VOBS used as an object for AOTT).

Each ATS\_PGCI contains audio title set program chain general information (ATS\_PGC\_GI), an audio title set program information table (ATS\_PGCIT), an audio title set cell playback information table (ATS\_C\_PBIT), and an audio title set audio still video playback information table (ATS\_ASV\_PBIT).

ATS\_PGCIT includes one or more pieces of audio title set program information (ATS\_PGI#1 to ATS\_PGI#k), and ATS\_C\_PBIT includes the same number of pieces of audio title set cell playback information (ATS\_C\_PBI#1 to ATS\_C\_PBI#k) as the number of pieces of information ATS\_PGI.

On the other hand, ATS\_ASV\_PBIT includes ATS program audio still video playback information search pointers (ATS\_PG\_ASV\_PBI\_SRP#1 to ATS\_PG\_ASV\_PBI\_SRP#m), and ATS audio still video playback information (ATS\_ASV\_PBI#1 to ATS\_ASV\_PBI#n;  $n \leq m \leq 99$ ).

FIG. 27 shows the contents of audio title set program information ATS\_PGI shown in FIG. 26.

This ATS\_PGI includes the contents (ATS\_PG\_CNT)

of an audio title set program, an `ATS_PG` entry cell number (`ATS_PG_EN_CN`), the start presentation time (`FAC_ST_PTM`) of the first audio cell in `ATS_PG`, the playback time (`ATS_PG_PB_TM`) of `ATS_PG`, and the pause  
5 time (`ATS_PG_PA_TM`) of `ATS_PG`.

`ATS_PG_CNT` includes: an entry representing the relationship between the previous and current programs; an entry representing the relationship between the playback time stamps of the previous and current  
10 programs; an entry (`ATRN`) representing the attribute of AOB or that of an audio stream in VOB; and an entry (`DM_COEFTN`) indicating a coefficient table number to mix down AOB in `ATS_PG` (`AOB_PG`) having the number of `AOTT_AOB_ATR` or `AOTT_VOB_ATR` defined in `ATSI_MAT` using  
15 the number of `ATS_DM_COEFT` defined in `ATSI_MAT`.

`ATS_PG_EN_CN` includes an entry of the number (1 to 255) of the first `ATS` cell that forms `ATS_PG`.

`FAC_ST_PTM` includes an entry of lower 32 bits of the playback time stamp (or presentation time stamp  
20 `PTS`) described in the first audio packet in the first audio cell in `ATS_PG`.

`ATS_PG_PB_TM` describes the total playback time of cells in `ATS_PG`. The total playback time (seconds) assumes a value obtained by dividing `ATS_PG_PB_TM`  
25 (32-bit data) by 90,000.

`ATS_PG_PA_TM` describes the pause time that can be defined at the beginning of `ATS_PG`. This pause time

(seconds) assumes a value obtained by dividing  
ATS\_PG\_PA\_TM (32-bit data) by 90,000.

FIG. 28 shows the contents of audio title set cell  
playback information ATS\_C\_PBI shown in FIG. 26.

5           This ATS\_C\_PBI includes an index number  
(ATS\_C\_IXN) of a cell (ATS\_C) in an audio title set,  
the type (ATS\_C\_TY) of ATS\_C, the start address  
(ATS\_C\_SA) of ATS\_C, and the end address (ATS\_C\_EA) of  
ATS\_C.

10           In ATS\_C\_IXN, "01h" is written when ATT has no  
AOBS.

When ATT has AOBS, the contents of ATS\_C\_IXN  
change as follows in accordance with the contents of  
ATS\_C.

15           \*When ATS\_C is the silent cell or picture cell  
described above, "00h" is written in ATS\_C\_IXN as the  
index number of this ATS\_C; and

            \*when ATS\_C is the above-mentioned audio cell,  
one of "1" to "99" is written in ATS\_C\_IXN as the index  
20           number of this ATS\_C.

The index number of the first audio cell (having  
ATS\_C with the smallest number except for picture and  
silent cells) in ATS\_PG is set at "1". Similar index  
numbers may be appropriately assigned to one or more  
25           cells ATS\_C in ATS\_PG.

In all bits of ATS\_C\_TY, "0" is written when ATT  
has no AOBS.

On the other hand, when ATT has AOBS, the composition (ATS\_C\_COMP) of ATS\_C and its usage (ATS\_C\_Usage) are written in ATS\_C\_TY.

More specifically, when the cell of interest is an audio cell consisting of only audio data, "00b" is written in ATS\_C\_COMP (2 bits);

when the cell of interest is an audio cell consisting of audio data and real time information, "01b" is written in ATS\_C\_COMP (2 bits);

when the cell of interest is a silent cell consisting of only audio data, "10b" is written in ATS\_C\_COMP (2 bits); and

when the cell of interest is a picture cell consisting of only still picture data, "11b" is written in ATS\_C\_COMP (2 bits).

On the other hand, ATS\_C\_Usage is written with data (0001b) indicating the usage as a "spotlight part" for highlighting (spotlighting) the currently displayed specific part of audio manager menu AMGM.

When ATS has AOTT\_AOBS, ATS\_C\_SA describes the start address of ATS\_C expressed by the relative logical block number from the first logical blocks of AOTT\_AOBS which records that ATS\_C.

On the other hand, when ATS has no AOTT\_AOBS, ATS\_C\_SA describes the start address of ATS\_C expressed by the relative logical block number from the first logical block in AOTT\_VOBS which records that ATS\_C.

When ATS has AOTT\_AOBS, ATS\_C\_EA describes the end address of ATS\_C expressed by the relative logical block number from the first logical blocks of AOTT\_AOBS which records that ATS\_C.

5           On the other hand, when ATS has no AOTT\_AOBS, ATS\_C\_EA describes the end address of ATS\_C expressed by the relative logical block number from the first logical block in AOTT\_VOBS which records that ATS\_C.

10           FIG. 29 is a block diagram showing an example of an apparatus for playing back information recorded on the audio zone shown in FIG. 3 or the video zone shown in FIG. 4 from the optical disc (DVD audio disc) shown in FIG. 1. This playback apparatus has an arrangement of a DVD video-DVD audio compatible player that can  
15           play back not only audio data but also video data. (Although the detailed description of the arrangement will be omitted, this player may be compatible with existing CDs.)

20           The optical disc playback apparatus shown in FIG. 29 comprises remote controller 5 for accepting user's operations, remote controller receiver 4A for receiving the operation state of remote controller 5, key input portion 4 for accepting user's operations on the playback apparatus main body side, and panel  
25           display 4B which informs the user of his or her operation result, the playback process of DVD audio disc 10, and the like, and is arranged on the playback

apparatus main body (and/or remote controller).

As external devices in addition to these devices,  
monitor 6, and loudspeakers 8L and 8R are prepared.

(The illustrated loudspeakers are used for a 2-channel  
5 stereophonic system. However, upon multichannel  
playback, a required number of loudspeaker systems and  
their drive amplifiers are prepared separately.)

Key input portion 4, panel display 4B, remote  
controller 5, and monitor 6 make up a visual user  
10 interface. Monitor 6 is used not only as a playback  
video monitor of a DVD audio disc with a still picture,  
but also as a display means for, e.g., on-screen  
display OSD or the like. Monitor 6 is not limited to  
a direct-view type CRT display, liquid crystal display,  
15 plasma display, or the like, but may comprise a video  
projector for projecting various video data (menu  
window, still picture obtained by taking the recording  
site, and the like) including OSD information onto  
a large screen, in addition to the direct-view type  
20 display.

User operation information input at remote  
controller 5 is supplied to microcomputer (MPU or CPU)  
500 of system controller 50, which controls the  
operation of the overall playback apparatus, via remote  
controller receiver 4A. Controller 50 also includes  
25 ROM 502 which stores a control program and the like  
executed by MPU 500.

User operation information input at key input portion 4 is directly supplied to MPU 500. MPU 500 appropriately displays the operation conditions (various setup states and playback information of a DVD disc) of the playback apparatus corresponding to the user operation information on panel display 4B.

MPU 500 is connected to RAM 52 and memory interface (memory I/F) 53. The I/O control of RAM 52 is made via memory I/F 53. MPU 500 uses RAM 52 as a work area, and controls the operations of disc drive 30, system processor 54, video decoder 58, audio decoder 60, sub-picture decoder 62, and DAC & reproduction processing block 64 on the basis of various processing programs stored in ROM 502.

Disc drive 30 rotates disc 10 set on a tray (inside DISC-TRAY-INLET in FIG. 30) of the playback apparatus main body, and reads out from disc 10 recorded data (in addition to audio data including voice/music information, main picture data/video data containing moving picture information/still picture information, sub-picture data containing superimposed dialog information/menu information, and the like if they are recorded on disc 10). Readout data are subjected to signal processing such as signal demodulation, error correction, and the like, and are converted into a data sequence in the pack format (see FIGS. 6 to 8). Then, the data sequence is sent to system

processor 54.

System processor 54 has a packet transfer processor (not shown) which determines the types of various packets contained in data played back from disc 10, and distributes data in these packets to the  
5 corresponding decoders (58 to 62).

The packet transfer processor segments the data sequence in the pack format from the disc drive 30 in units of types of packs (navigation pack, video pack, sub-picture pack, audio pack, real time information  
10 pack, and still picture pack). Each segmented pack records transfer time data and ID data indicating the type of data.

System processor 54 transfers the video pack, sub-picture pack, and audio pack respectively to video  
15 decoder 58, sub-picture decoder 62, and audio decoder 60 with reference to the transfer time data and ID data of these packs. Note that the still picture pack is transferred to video decoder 58. The audio pack corresponding to silent cells or real time information pack  
20 is transferred to audio decoder 60.

Also, system processor 54 transfers control data in the navigation pack to RAM 52 via memory I/F 53. MPU 500 controls playback operations of the individual  
25 units of the playback apparatus main body with reference to the transferred control data in the RAM.

Video decoder 58 generates video data before

compression by decoding MPEG-encoded video data in the video pack transferred from system processor 54.

Sub-picture decoder 62 generates bitmap sub-picture data before compression by decoding  
5 runlength-compressed sub-picture data in the sub-picture pack transferred from system processor 54.

This sub-picture decoder 62 has a highlight processor (not shown) for highlighting (in case of DVD video) or spotlighting (in case of DVD audio) decoded  
10 sub-picture data in addition to a sub-picture decoder for decoding sub-picture data from system processor 54.

The sub-picture decoder obtains an original bitmap picture by expanding pixel data (including emphasized pixels, pattern pixels, background pixels, and the  
15 like) in units of a predetermined number of bits (2 bits), which have been runlength-compressed according to a predetermined rule.

The highlight processor (not shown) executes corresponding highlight processing (spotlight  
20 processing) in accordance with highlight information or spotlight information (e.g., the X- and Y-coordinate values which define a rectangular region where a menu selection item is displayed, color code, and highlight color (spotlight color)/contrast value) supplied from  
25 MPU 500.

The highlight processing can be used as a means for helping the user easily recognize a specific

displayed item (a button for selecting a specific item such as the type of playback spoken language, the type of language used for the playback superimposed dialog, and the like; or a button for selecting a specific item  
5 such as the sampling frequency, the number of quantization bits, the number of playback channels, and the like of playback sound) on the visual user interface on monitor 6.

Incidentally, one spotlight part is defined as  
10 a cell. The spotlight is used to specify specially selected part by the content provider. A DVD audio player may selectively present the spotlight parts as an optional function.

When the color and contrast of the decoded  
15 sub-picture data in units of pixels have been changed in correspondence with the highlight information (spotlight information), the changed sub-picture data is supplied to a picture synthesizer (not shown) in video processor 640. The picture synthesizer  
20 synthesizes the decoded picture data and the sub-picture data after the highlight processing (spotlight processing), and the synthesized picture is displayed on monitor 6.

RAM 52 mentioned above includes a menu table for  
25 storing the start addresses of a sub-picture menu, audio menu, angle menu, chapter (program) menu, and the like. To emphasize a specific portion of these menus,

the highlight processing (spotlight processing) may be used.

Audio decoder 60 generates monaural, 2-channel stereophonic, or multichannel stereophonic audio data by decoding audio data in the audio pack transferred from system processor 54. When audio data in the audio pack is compression-encoded data (MPEG, AC-3, or the like), that data is decoded inside audio decoder 60.

Video data (normally, moving picture signal) decoded by video decoder 58, and sub-picture data (normally, superimposed dialog or menu bitmap data) decoded by sub-picture decoder 62 are transferred to video processor 640. In this video processor 640, the video data and sub-picture data are mixed at a predetermined ratio to obtain a final analog video signal (composite video signal, separate S signal, or component signals Y/Cr/Cb). Then, the analog video signal is output to monitor 6.

When the video data decoded by video decoder 58 corresponds to main part of a movie on DVD video disc 10, the sub-picture data normally corresponds to a superimposed dialog in the language selected by the user. Hence, the movie with the superimposed dialog is played back on monitor 6.

When the video data decoded by video decoder 58 corresponds to menu part of the movie, the sub-picture data normally corresponds to characters that make up

the menu and user selection buttons (appropriately highlighted). In such case, a menu background (still picture or moving picture) is displayed on monitor 6 on the basis of the video data, and buttons, the display states of which change in correspondence with user's selection operations, are superimposed on the background picture on the basis of the sub-picture data.

On the other hand, when the video data decoded by video decoder 58 corresponds to a still picture of DVD audio disc 10, the sub-picture data corresponds to, e.g., comment text in the language selected by the user. In such case, a still picture with text is displayed on monitor 6.

Note that video processor 640 includes an OSD unit for generating on-screen display (OSD) data. User's operation at, e.g., remote controller 5 is processed by MPU 500, and the processing result is sent from MPU 500 to the OSD unit of video processor 640. The OSD unit generates picture data corresponding to the processing result from MPU 500, and outputs it in the analog video signal format to monitor 6.

In other words, video processor 640 converts and multiplexes digital signals output from video decoder 58 and sub-picture decoder 62 into an analog signal.

Frame memory 642 is connected to video processor 640. Frame memory 642 is used for multiplexing pictures of the video and sub-picture data, and is also

used for n-split (e.g., 4-split) multiscreen display.

Frame memory 642 can be used when video data from video decoder 58 is frozen as a still picture in case of, e.g., a chapter search, and the still picture is sent to monitor 6 before the target chapter begins to be played back.

Furthermore, frame memory 642 can also be used when an OSD display corresponding to the user's operation result is multiplexed on video data.

Audio data decoded by audio decoder 60 is transferred to DAC & output circuit 644. DAC & output circuit 644 converts the audio data (digital) from audio decoder 60 into an analog audio signal, appropriately amplifies the signal, and then sends that signal to loudspeakers 8L and 8R.

When multichannel audio data are mixed down to 2-channel audio data on the basis of the entry of `ATS_DM_COEFT` in audio title set information management table `ATSI_MAT` (cf. explanation of FIG. 25), the mix-down coefficient (parameter) is sent from MPU 500 to DAC & output circuit 644. Then, DAC & output circuit 644 mixes down multichannel audio data decoded by audio decoder 60 to 2-channel data on the basis of the received coefficient, and outputs 2-channel analog audio signals.

Video processor 640, frame memory 642, and DAC & output circuit 644 make up the DAC & reproduction

processing block.

Note that system processor 54, video decoder 58, audio decoder 60, and sub-picture decoder 62 respectively include system time clock (STC) for operation timings and a register for temporarily storing commands, information, and the like sent from system MPU 500.

FIG. 30 shows an example of the front panel of the playback apparatus shown in FIG. 29. This front panel has fluorescent display (FL display) 4B corresponding to panel display 4B shown in FIG. 29.

FL display 4B shown in FIG. 30 displays an album name and/or group name as characters in accordance with audio text data manager ATXTDT\_MG in AMGI. In the example shown in FIG. 9, "Vol. 1 of works of Beethoven" is displayed as the album name, and "Symphony No. 1" is displayed as the group name.

Also, a numeric indicator on the left side of FL display 4B displays a title number (in case of DVD video) or group number (in case of DVD audio), track number, and index number.

When optical disc 10 set on the disc tray shown in FIG. 30 is an AV disc (a disc having ATT\_SRP shown in FIG. 20), a character indicator on the right side near the center of FL display 4B highlights "AV disc", as shown in FIG. 30. When the set disc is an A disc (a disc having AOTT\_SRP shown in FIG. 22), "A disc" is

highlighted on the character indicator on the right side of FL display 4B. When the set disc is a video disc which has no ATS but consists of only VTS (a disc having no ATS directory shown in FIG. 12), "video disc" is highlighted on the character indicator on the right side of FL display 4B.

Furthermore, a numeric indicator on the right side of FL display 4B indicates the sampling frequency and the number of quantization bits of the audio contents to be played back. These indications can be automatically made on the basis of the contents of AOTT\_AOB\_ATR or AOTT\_VOB\_ATR in audio title set information management table ATSI\_MAT.

A DVD audio player that plays back DVD audio disc (A disc or AV disc) may include the following two types of players:

- <C1> a player that can play back both picture and audio data complying with the audio format, i.e., a player that processes both AOTT and AVTT; and
- <C2> a player that can play back only audio data complying with the audio format, i.e., a player that processes only AOTT.

The player of type <C1> suffices to load only search information (FIG. 20) described in ATT\_SRPT to playback contents.

On the other hand, the player of type <C2> suffices to load only search information (FIG. 22)

described in AOTT\_SRPT to playback contents.

In this manner, the playback methods of the respective types of players can be facilitated. Of course, the player of type <C2> cannot play back ATT#1  
5 and ATT#9 in FIG. 23 since they do not include any AOTT.

The above-mentioned DVD audio player shown in FIG. 29 corresponds to that of type <C1>. The operation of this player will be explained below taking playback of disc 10 with the data structure shown in  
10 FIG. 14 as an example.

When disc 10 with the data structure shown in FIG. 14 is to be played back by a normal DVD video player, this video player loads VMG in the VTS directory under the root directory shown in FIG. 12,  
15 and determines a title to be played back on the basis of the loaded information. The player plays back all or some objects in object set VOBS#1 or VOBS#2 in FIG. 14 in accordance with an instruction of a playback unit defined in VTS corresponding to the determined  
20 title.

In the data structure shown in FIG. 14, the video player recognizes areas other than VMG, VTS#1, and VTS#2 as other recording area 73 (FIGS. 3 and 4). For this reason, the video player can normally play  
25 back VOBS#1 and VOBS#2 independently of data recorded in the areas recognized as other recording area 73. In this case, objects present in other recording area

73 cannot be played back by the video player.

On the other hand, disc 10 with the data structure shown in FIG. 14 is to be played back by the DVD audio player shown in FIG. 29, this audio player loads AMG in the ATS directory under the root directory shown in FIG. 12, and plays back contents on the basis of the loaded information. Upon title designation by AMG, a playback unit defined in VTS recorded in DVD video zone 72 (FIG. 4) can be designated as well as a playback unit defined in ATS recorded in DVD audio zone 71 (FIG. 3).

The playback unit defined in ATS designates not only the playback route of objects (AOBS#1 or AOBS#2) recorded in DVD audio zone 71 but also designates that of audio data recorded in objects (e.g., VOBS#1) in DVD video zone 72.

VOBS#1 indicated by hatching in FIG. 14 exemplifies DVD video part shared from the DVD audio side. Note that arrow (a) indicates a case wherein the playback unit in video zone 72 is referred to, and arrow (b) indicates a case wherein audio part of objects (VOBS#1) in video zone 72 is referred to by the playback unit in audio zone 71.

When audio part of objects (VOBS#1) in video zone 72 is referred to by the playback unit in audio zone 71, the shared reference part (shared by DVD audio and DVD video) can have a definition different from that of

individual units (cell, program, program chain) defined by definition information (VTSI) of the playback unit in video zone 72. That is, the video player and audio player may have different playback methods for even an  
5 identical object (see FIG. 5).

Note that the shared part is used in units of video object units VOBUs. This is because audio data streams and other (video and sub-picture) data streams are packed and time-division multiplexed in units of  
10 VOBUs.

As shown in FIG. 14, since audio zone 71 is physically located in front of video zone 72, the addresses of playback units designated from their management information can be limited to those in  
15 the positive direction. In this way, design and development of an audio player can be simplified.

Note that the operation of the video player using the data structure shown in FIG. 16 is the same as that in FIG. 14 mentioned above.

20 The operation of the audio player using the data structure shown in FIG. 16 is nearly the same as that in FIG. 14. The audio player jumps to the beginning of AMG to load management information, and plays back object sets AOBS#1 and AOBS#2. Although AOBS#1 is an  
25 object in the DVD video zone, ATSI#1 re-defines cells, programs, and a program chain of AOBS#1. Note that AOBS#1 is also used in units of VOBUs.

The embodiment described above has exemplified a case wherein DVD audio data and/or DVD video data contained in volume space 28 are recorded on optical disc 10. However, the data structure (FIGS. 3 to 28) of the present invention is not limited to data recorded on optical disc 10. For example, bit streams containing data with the structure shown in FIGS. 3 and 12 may be received via digital broadcast or digitally communication. (In such case, a radio wave or communication line serves as a medium. Also, a DVD broadcast receiver or a communication terminal such as a personal computer serves as a DVD audio player.)

FIG. 31 is a plan view of double-layered optical disc OD used as another example of a two-substrate-joined information recording medium of the present invention, when viewed from the read laser receiving face side. This optical disc OD has an outer diameter of 120 mm, center hole 70 defining its inner diameter of 15 mm, and a thickness of 1.2 mm, and is prepared by joining two 0.6-mm thick polycarbonate substrates. Each of the joined substrates is formed with a doughnut-like information recording layer (FIG. 31 illustrates only layer 10 of one substrate). The inner diameter of this doughnut-like information recording layer is approximately 45 mm, and its outer diameter is around 117 mm in maximum. Polymer film spacer 60 (an inner diameter of 15 to 16 mm, an outer diameter of 20

to 21 mm, and a thickness around 40  $\mu\text{m}$  to 70  $\mu\text{m}$  (e.g., 50  $\mu\text{m}$ ) is placed coaxial with center hole 70 of optical disc OD with the aforementioned structure, while being sandwiched between the two substrates.

5           As a polymer film used for spacer 60, a polycarbonate film, polyethylene terephthalate film, polyimide film, and the like can be used unless otherwise specified. When label information is printed there, a polycarbonate film is suitable. In this case, upon printing a label, the practical thickness after printing is controlled to a desired thickness (e.g., 10           50  $\mu\text{m}$ ).

          Note that spacer 60 may be omitted as long as the spacing between joined substrates 30 and 40 can be managed to fall within the range between 40  $\mu\text{m}$  to 70  $\mu\text{m}$ . 15

          FIG. 32 is a partially enlarged schematic sectional view of double-layered optical disc OD shown in FIG. 31. As shown in FIG. 32, this disc OD is comprised of polycarbonate substrate 30 for holding a first information recording layer, gold thin film (first recording layer; a thickness of 11 to 14 nm, e.g., around 13 nm) 10 on which first information is recorded, adhesive layer 50 which is transparent with respect to laser beam RL, aluminum-molybdenum alloy thin film (second information recording layer; a thickness of 40 nm or more, e.g., around 100 nm) 20, and polycarbonate substrate 40 for holding the second 25

information recording layer, when viewed from the receiving face of read laser beam RL. On the surface of substrate 40 opposite to the read laser RL receiving face of substrate 30, label LB that prints information (visual pattern information such as characters, graphics, patterns, and the like) pertaining to recorded information (the first information and second information) is adhered, as needed.

Film spacer 60 coaxially sandwiched between substrates 30 and 40 at the position of center hole 70 has a thickness of 50  $\mu\text{m}$ , and adhesive layer 50 sandwiched between substrates 30 and 40 at the same level as spacer 60 has a constant thickness (around 55  $\pm$  15  $\mu\text{m}$ ) nearly the same as the film thickness (50  $\mu\text{m}$ ) of spacer 60. If the thickness of adhesive layer 50 need be increased, the film thickness of spacer 60 can be increased accordingly.

By selecting the film thickness of gold thin film 10 that forms the first information recording layer to fall within the range from 11 nm to 14 nm (preferably, around 13 nm), read laser reflected light beams having nearly the same intensities can be obtained from both first and second information recording layers 10 and 20.

Note that first information recording layer 10 may be formed of another material (gold alloy, copper, silver, brass, copper-zinc alloy, copper-aluminum alloy, or the like) that exhibits a laser reflectance and

laser transmittance equivalent to those of the gold thin film with respect to read laser beam having a wavelength of 650 nm (or 635 nm).

By selecting the film thickness of the aluminum-molybdenum alloy thin film 20 that forms the second information recording layer to be 40 nm or more, the laser reflectance of film 20 can be set at a practically sufficient value (reflectance of 80% or more). In this embodiment, the film thickness setup value of second information recording layer 20 is selected to be around 100 nm.

Second information recording layer 20 can be formed of aluminum alone. However, using an alloy of aluminum and a high-melting point metal such as molybdenum, tantalum, cobalt, chromium, titanium, platinum, or the like, aging (environmental reliability) of the reflectance of thin film 20 for the second information recording layer can be greatly reduced.

Molybdenum has a function of improving the oxidation resistance of second information recording layer 20, but its mixing ratio has a proper range, i.e., falls within the range from 1 to 20 at% in practice. The ratio of molybdenum in aluminum-molybdenum alloy thin film 20 preferably falls within the range from 1 to 20 at%. In this embodiment, the ratio of molybdenum is set at 20 at%. If this ratio is higher than 20 at%, the laser reflectance of second information recording

layer 20 lowers even when thin film 20 has a film thickness of 40 nm or more.

The wavelength of read laser beam RL may be 635 nm in addition to 650 nm mentioned above, or may be shorter. However, if a different wavelength is used, the optimal film thickness of spacer 60 may change (the optimal film thickness may also change depending of the physical properties of adhesive layer 50). It is practical to experimentally determine the optimal film thickness using a plurality of samples after the laser wavelength, the material of adhesive layer 50, the materials of substrates 30 and 40 used in practice are determined. This determination is made so that the C/N (carrier to noise ratio) of the read signal from each of recording layers 10 and 20 has a desired value or more, and a sufficiently high joint strength of substrates 30 and 40 is assured.

The following physical parameters of joined optical disc OD shown in FIGS. 31 and 32 may be used.

[Outer Diameter]

12-cm disc >  $120.00 \pm 0.30$  mm

8-cm disc >  $80.00 \pm 0.30$  mm

[Center Hole 70]

12-cm/8-cm (common) >  $15.00 + 0.15$  mm,  $-0.00$  mm

[Joined Thickness]

12-cm/8-cm (common) >  $1.20 + 0.30$  mm,  $-0.06$  mm

[Inner Diameter of Disc Clamp Area]

12-cm/8-cm (common) > 22.0 mm (maximum)

[Outer Diameter of Disc Clamp Area]

12-cm/8-cm (common) > 33.0 mm (minimum)

5 [Thickness of Disc Clamp Area]

12-cm/8-cm (common) > 1.20 + 0.20 mm, -0.10 mm

[Joined Disc Weight]

12-cm disc > 13g to 20g

8-cm disc > 6g to 9g

10 [Moment of Inertia of Joined Disc]

12-cm disc > 0.040 g·m<sup>2</sup> (maximum)

8-cm disc > 0.010 g·m<sup>2</sup> (maximum)

[Dynamic Balance of Joined Disc]

12-cm disc > 0.010 g·m (maximum)

15 8-cm disc > 0.0045 g·m (maximum)

FIG. 33 schematically shows a partial section of a modification of the one-side read type two-substrate-joined double-layered disc shown in FIG. 32, i.e., joined optical disc OD having a single information recording layer.

20 In the modification shown in FIG. 33, information recording layer 20 shown in FIG. 32 is replaced by dummy layer 20d on which no information is recorded. When information recording layer 10 can store the total volume of data to be stored in disc OD, the modification shown in FIG. 33 can be used. Dummy layer 20d can be formed of an aluminum-based metal thin film painted

with a given information pattern having no practical contents. (Note that "painted with a given information pattern having no practical contents" includes not only a case wherein nothing is really recorded, but also a case wherein simple data such as "0"s or "1"s are fully recorded on the entire recording face.)

FIG. 34 shows a modification of the structure shown in FIG. 33, and schematically illustrates a partial section of two-substrate-joined optical disc OD having a single information recording layer.

In the modification shown in FIG. 34, information recording layer 20 shown in FIG. 32 is replaced by dummy & label layer 20db having a label pattern. If this optical disc OD is found to be a joined single-layered disc by initially reading some information on information recording layer 10, the playback apparatus of this disc OD can be initialized not to access information on dummy & label layer 20db. In such case, since dummy & label layer 20db need not reflect read laser beam RL, the material of dummy & label layer 20db can be selected from various materials. For example, a polycarbonate film printed with a label pattern may be used as dummy & label layer 20db.

In the modifications shown in FIGS. 33 and 34, the thickness of dummy layer 20d or 20db need not be especially controlled. However, the thickness of substrate 40 including that of dummy layer 20d or 20db

is controlled to a predetermined value (0.6 mm).

Using transparency of polycarbonate substrates 30 and 40, characters, patterns, and the like associated with information recorded on the disc may be printed  
5 on spacer 60 sandwiched between substrates 30 and 40. In this way, the spacer 60 portion at the center of the disc can be used as a disc label although its visual information entry amount is small.

In the aforementioned embodiment, an aluminum-  
10 molybdenum alloy thin film is used as second information recording layer 20. However, the present invention is not limited to such specific film. Depending on the embodiment or modification of the present invention, a pure aluminum layer, gold layer,  
15 an alloy layer of aluminum and a high-melting point metal (tungsten, tantalum, nickel, cobalt, platinum, chromium, titanium, or the like) other than molybdenum, which has a high melting point, high strength, and high oxidation resistance, and the like may be used in  
20 practice. However, the material of first information recording layer 10 is limited to that (gold alloy, copper, silver, brass, copper-zinc alloy, copper-aluminum alloy, or the like) that exhibits a laser reflectance and laser transmittance equivalent to those  
25 of gold with respect to a laser beam with a specific wavelength used, when the selected material forms a thin film.

In the above description, ultraviolet setting resin layer (adhesive layer) 50 has a thickness of 50  $\mu\text{m}$ . However, when joined disc OD shown in FIG. 31 is a read-only DVD audio disc (DVD-ROM), this thickness is preferably selected from the range from 40  $\mu\text{m}$  to 70  $\mu\text{m}$ . When joined disc OD shown in FIG. 31 is a read/write DVD audio disc (DVD-RAM or DVD-RW), the thickness of adhesive layer 50 is often preferably smaller than that of a read-only disc. In such case, the thickness of adhesive layer 50 can be selected from the range from 20  $\mu\text{m}$  to 40  $\mu\text{m}$ .

As an outer size of optical disc OD, 5" type (diameter of 120 mm) and 3.5" type (diameter of 80 mm) have been exemplified. The present invention can also be applied to joined optical discs having other sizes such as 2.5" type (diameter of 63 mm) and the like. In this case, the optimal adhesive layer thickness (or the thickness of spacer 60) can be determined in correspondence with the disc size, disc material, disc purpose (ROM or RAM), the type of adhesive, and other conditions.

In the above description, a film ring similar to a disc has been exemplified as spacer 60. However, the shape of spacer 60 is not limited to the ring shape. The inner hole of spacer 60 may have an arbitrary polygonal shape. Similarly, the outer shape of spacer 60 may have an arbitrary polygonal shape as long as

the diameter of its circumscribed circle does not enter the region of the information recording layer shown in FIG. 31. For example, a polygonal film (e.g., a thickness of 50  $\mu\text{m}$ ) which has a hexagonal outer shape that is circumscribed by a circle having a diameter of 33 mm, and an octagonal inner shape that inscribes a circle having a diameter of 15 mm may be used as spacer 60. When disc recorded information (characters, symbols, or graphics) is printed on spacer 60, spacer 60 is preferably not limited to a circular ring to improve its value (mainly in terms of its design).

FIG. 35 is a graph showing changes in allowable range of the thickness (ordinate) of a substrate (30 or 40) to be joined as a function of the refractive index (abscissa) of the substrate material when coherent light having a wavelength of 650 nm is used and a pair of substrates (30, 40) each having a single substrate/single recording layer structure shown in FIG. 32 is used.

In this graph, if the refractive index of the substrate is 1.45, the substrate thickness is controlled to fall within the range from the upper limit of 0.643 (point P01) to the lower limit of 0.583 (point P03) (the central value is 0.615 mm at point P02). For example, if the refractive index of a polycarbonate substrate is 1.56, the substrate thickness is controlled to fall within the range from

the upper limit of 0.630 (point P11) to the lower limit of 0.570 (point P13) (the central value is 0.600 mm at point P12). If the refractive index of the substrate is 1.65, the substrate thickness is controlled to fall within the range from the upper limit of 0.630 (point P21) to the lower limit of 0.570 (point P23) (the central value is 0.600 mm at point P22).

In the embodiment of the present invention, a transparent substrate (30, 40) made of polycarbonate or the like, the thickness of which falls within the range bounded by points P01 to P23 in this graph is used.

FIG. 36 is a graph showing changes in allowable range of the thickness (ordinate) of a substrate to be joined as a function of the refractive index (abscissa) of the substrate material when coherent light having a wavelength of 650 nm is used and a pair of substrates each having a single substrate/dual recording layer structure shown in FIG. 32 are used.

In this graph, if the refractive index of the substrate is 1.45, the substrate thickness is controlled to fall within the range from the upper limit of 0.653 (point Q01) to the lower limit of 0.563 (point Q03). If the refractive index of the substrate is 1.56, the substrate thickness is controlled to fall within the range from the upper limit of 0.640 (point Q11) to the lower limit of 0.550 (point Q13) (the central value is approximately 0.595 mm). If the

refractive index of the substrate is 1.65, the substrate thickness is controlled to fall within the range from the upper limit of 0.640 (point Q21) to the lower limit of 0.550 (point Q23).

5           In the embodiment of the present invention, a transparent substrate (30, 40) made of polycarbonate or the like, the thickness of which falls within the range bounded by points Q01 to Q23 in this graph is used.

10           Incidentally, the term "video" used in this specification refers to a "movie" picture. No video ("movie" picture) can be added to an audio only title AOTT, while a "still" picture can be added to the AOTT. Thus, an audio title set directory AUDIO\_TS may contain still picture data but may not contain video data.

15           According to the present invention, the data structure of the DVD audio format can be realized in a form similar to that of the video format without modifying the DVD video format that has already been put into applications. In this case, an audio volume  
20           can exist in a single volume space to share objects of a video volume. A DVD disc (A disc or AV disc) formed with this data structure can play back appropriate objects in both the video player and audio player.

25           Since the data structure of the present invention is characterized by sharing some objects of DVD video without conflicting existing DVD video, DVD video and DVD audio can expand the infrastructure in cooperation

with each other. This also brings about secondary merits, i.e., a reduction of the manufacturing cost of playback apparatuses, media, and other associated products.

## C L A I M S

1. A digital information recording medium which records first and second contents having different purposes on a plurality of independent regions,

5            wherein said first and second contents respectively have first and second management blocks for managing playback of contents thereof, and

              said first management block has first information for managing access to the first and second contents.

10            2. A medium according to claim 1, wherein said second management block has second information for managing access to said second contents.

              3. A medium according to claim 1 or 2, wherein said first management block has physically or logically  
15 smaller addresses than addresses of said second management block or said second contents.

              4. A medium according to any one of claims 1 to 3, wherein said first contents contain information for accessing said second contents.

20            5. A medium according to any one of claims 1 to 4, wherein files of recording information are managed by a hierarchical file structure including:

              a first sub-directory including a data file which stores said first contents and a data file which stores  
25 said first information;

              a second sub-directory including a data file which stores said second contents and a data file which

stores said second information; and

a root directory including said first and second sub-directories.

5 6. A medium according to claim 5, wherein the data file in said first sub-directory includes an object which contains at least audio data but does not include any video data, and

the data file in said second sub-directory includes an object which contains video data.

10 7. A medium according to claim 6, wherein said first information contains first search information for accessing the object which contains the audio data but does not contain any video data, and second search information for accessing the object which contains the video data.

15 8. A medium according to claim 6 or 7, wherein said second information contains search information for accessing only the object which contains the video data.

20 9. A digital information playback apparatus for playing back audio or video contents from a digital information medium, which has the audio contents and an audio management block for managing playback of the audio contents, and the video contents and a video management block for managing playback of the video contents, and in which said audio management block  
25 includes audio management information for managing access to the audio and video contents, comprising:

management information extraction means for extracting contents of the audio management information from said digital information medium;

audio contents extraction means for extracting contents of the audio contents based on the contents of the audio management information; and

video contents extraction means for extracting contents of the video contents based on other contents of the audio management information.

10           10. An apparatus according to claim 9, wherein said digital information medium includes audio data which is digitally converted by a predetermined sampling frequency selected from a plurality of different sampling frequencies, and a predetermined number of quantization bits selected from a plurality of different numbers of quantization bits, and attribute information indicating the predetermined sampling frequency and the predetermined number of quantization bits used in the audio data,

20           said management information extraction means detects the predetermined sampling frequency and the predetermined number of quantization bits from the attribute information, and

25           said apparatus further comprises display means for displaying the detected predetermined sampling frequency and the detected predetermined number of quantization bits.

11. An information recording method for recording information on an information recording medium which has a volume space that includes an audio zone and a video zone located after said audio zone, comprising  
5 the steps of:

recording audio management information and audio contents in said audio zone; and

recording video management information and video contents on said video zone.

12. An information playback method for playing  
10 back information from an information recording medium on which an audio zone that records audio management information and audio contents, and a video zone that records video management information and video contents,  
15 are recorded, comprising the steps of:

accessing the audio or video contents based on the audio management information to play back contents thereof; and

accessing the video contents based on the video  
20 management information to play back contents thereof.

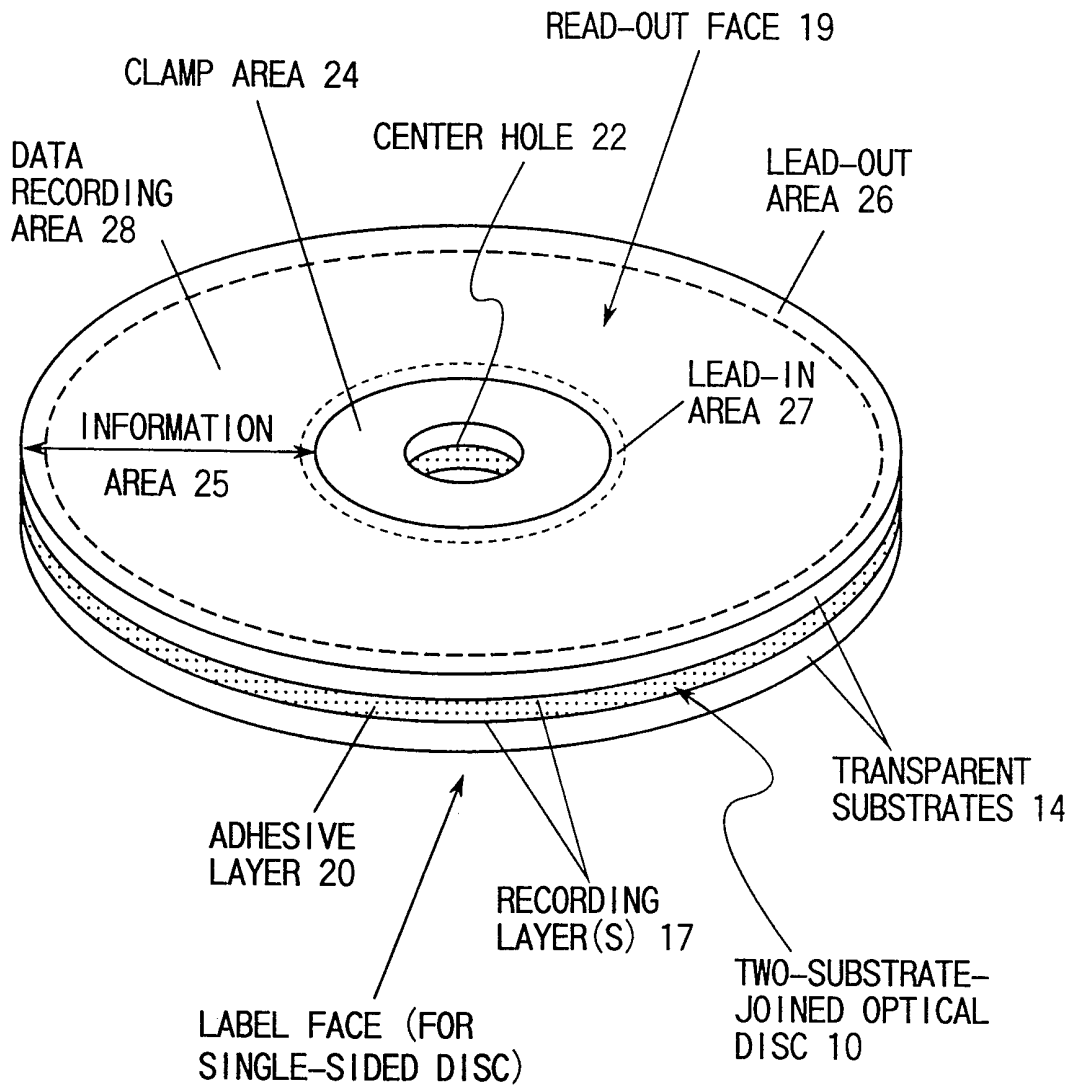

FIG. 1

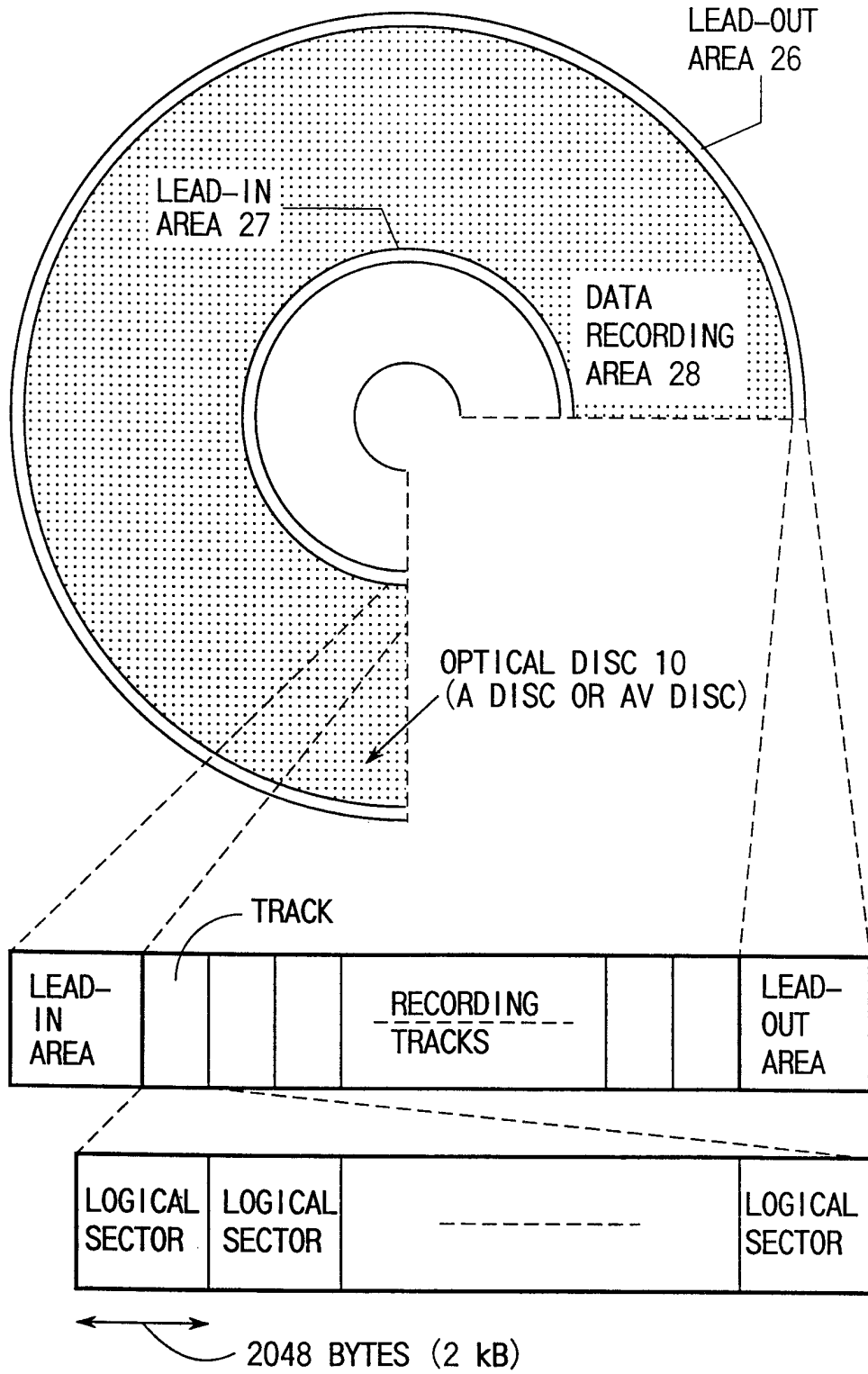

FIG. 2

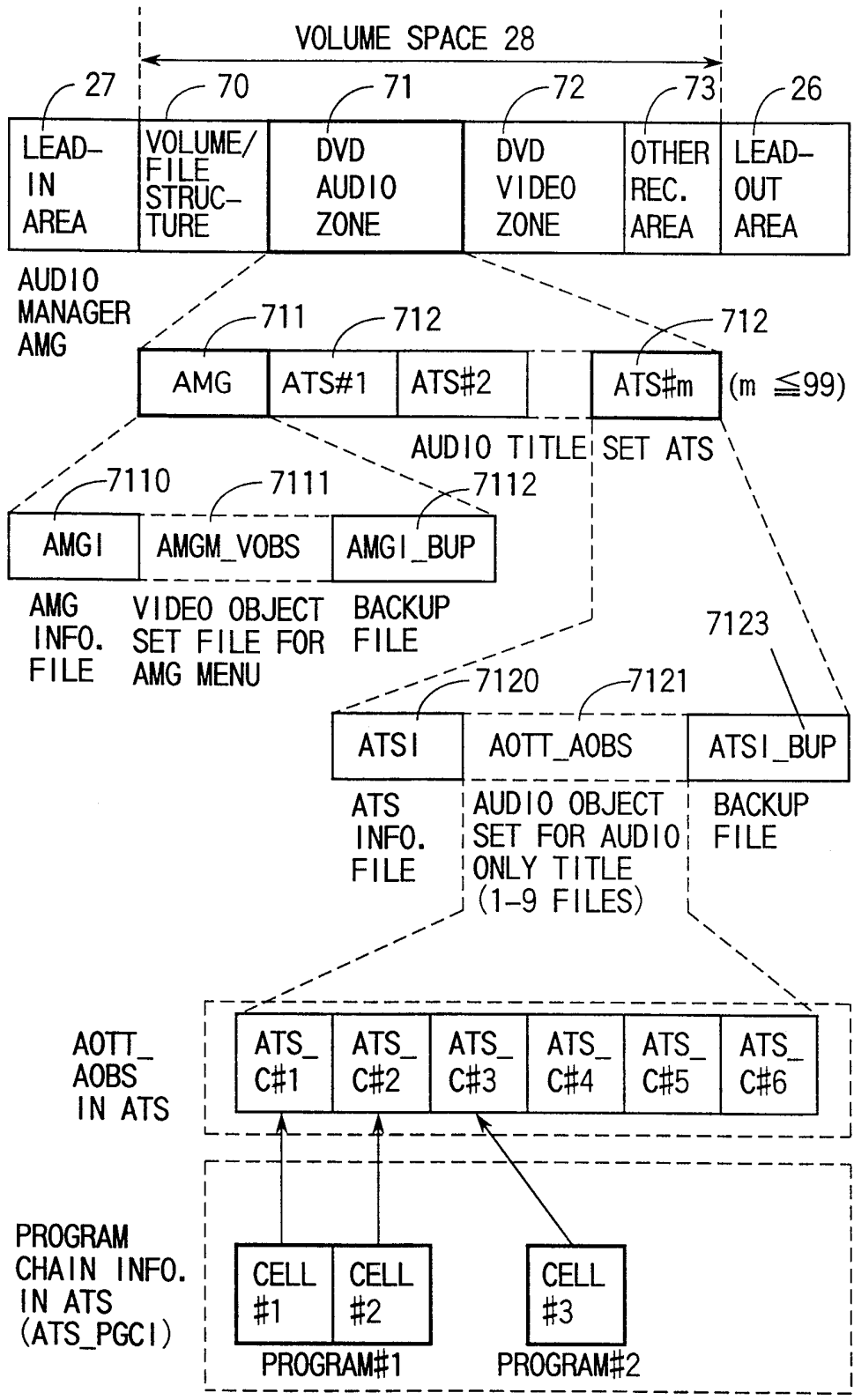

FIG. 3

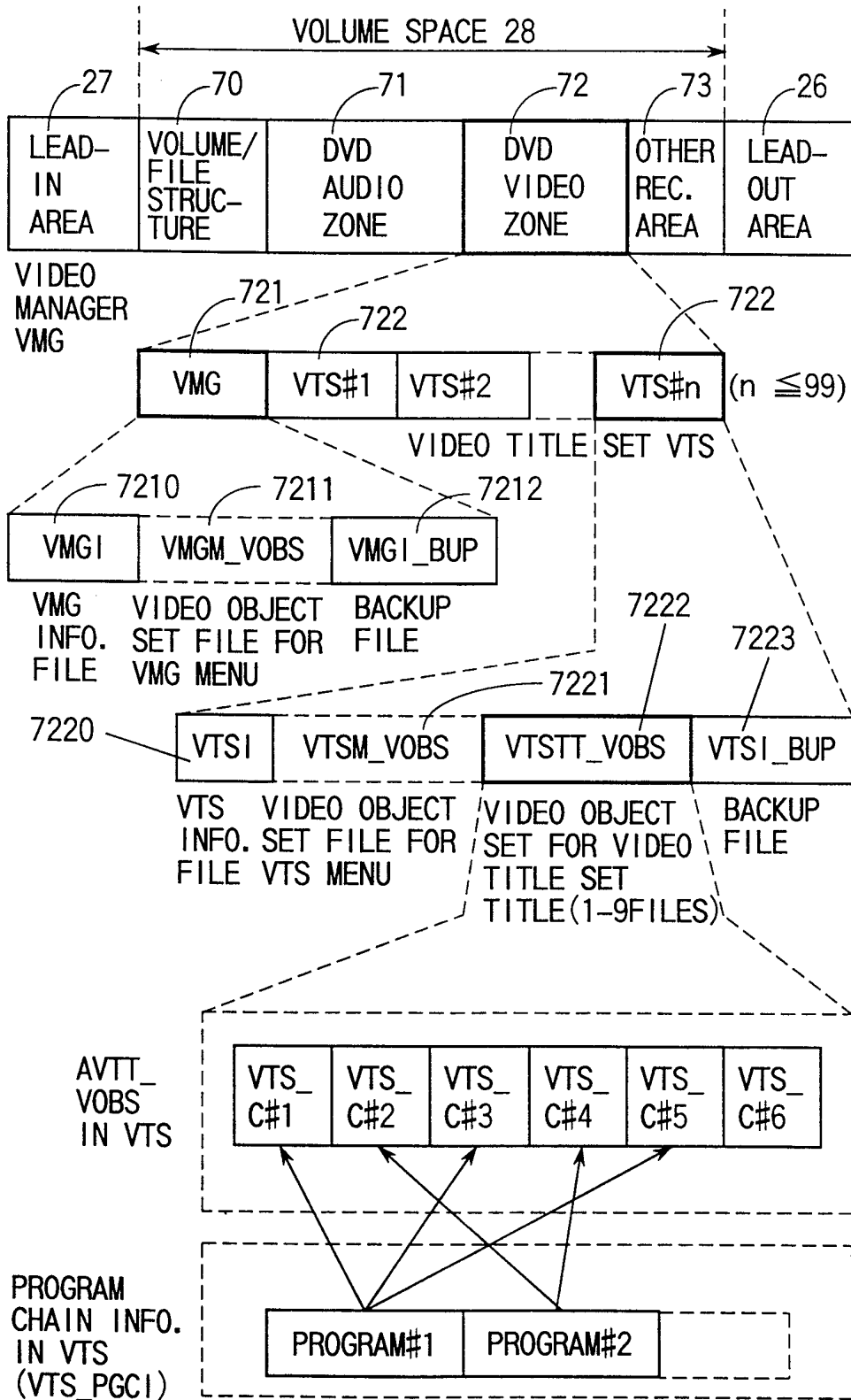

FIG. 4

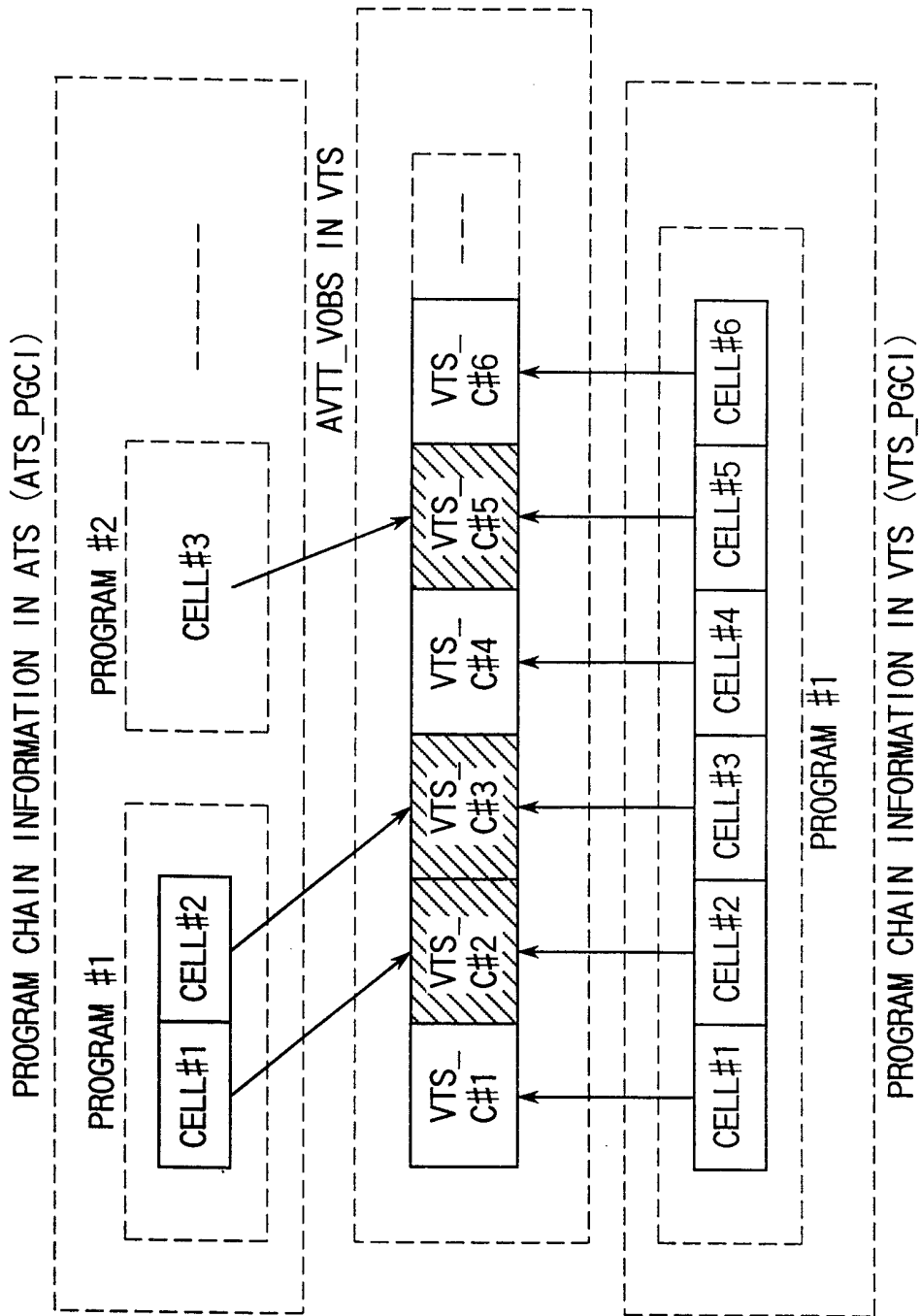

FIG. 5

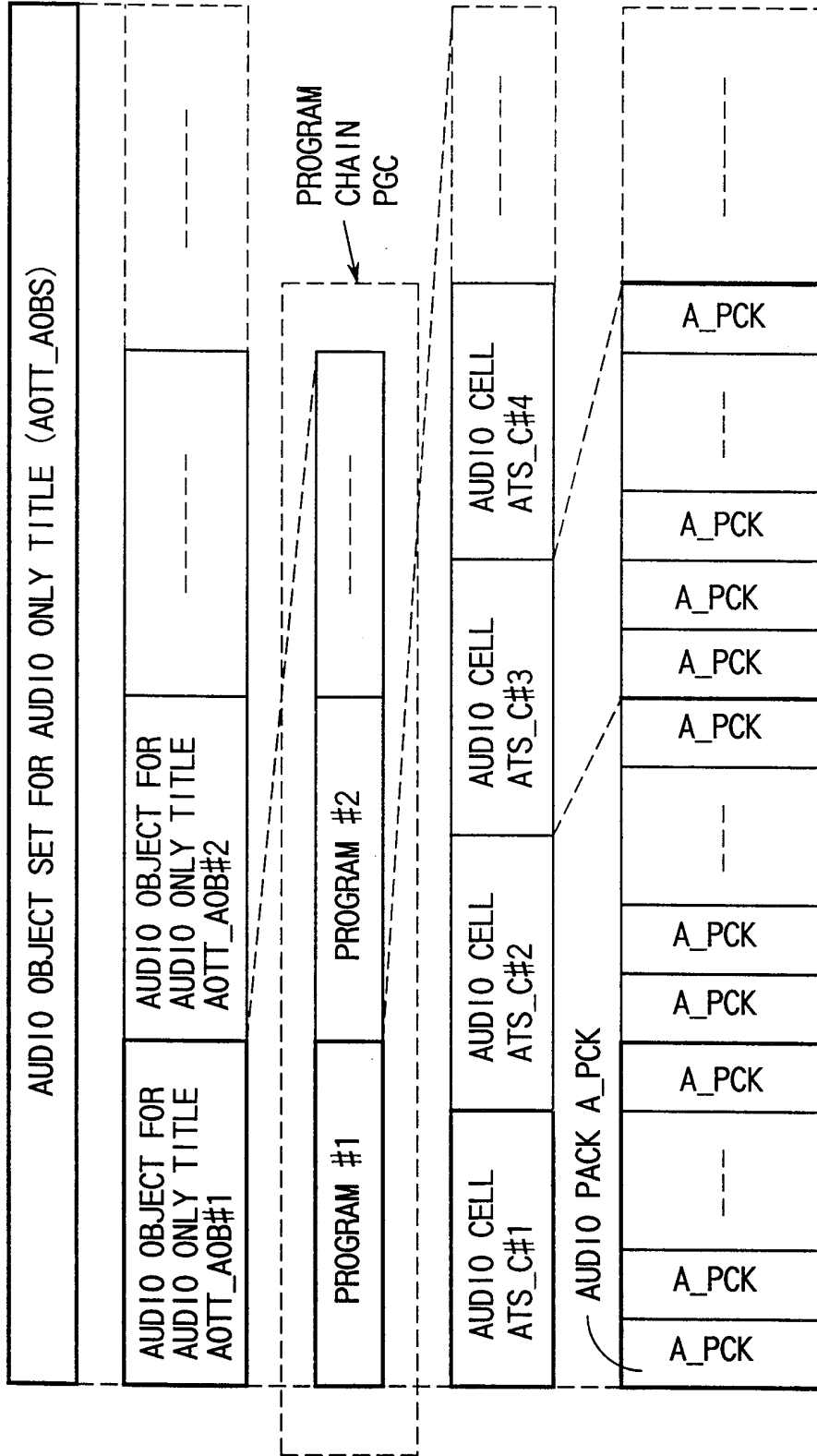

FIG. 6

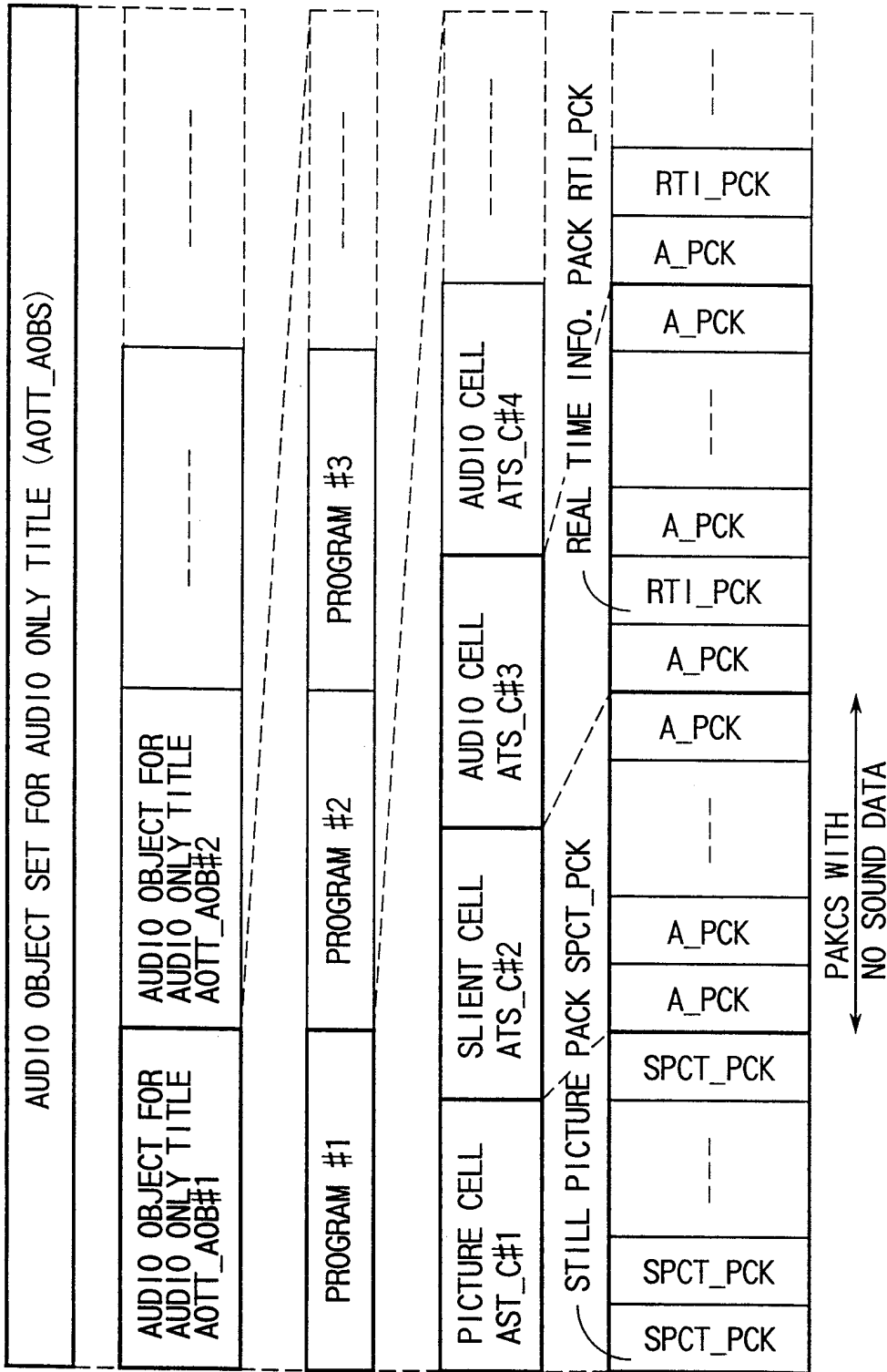

FIG. 7

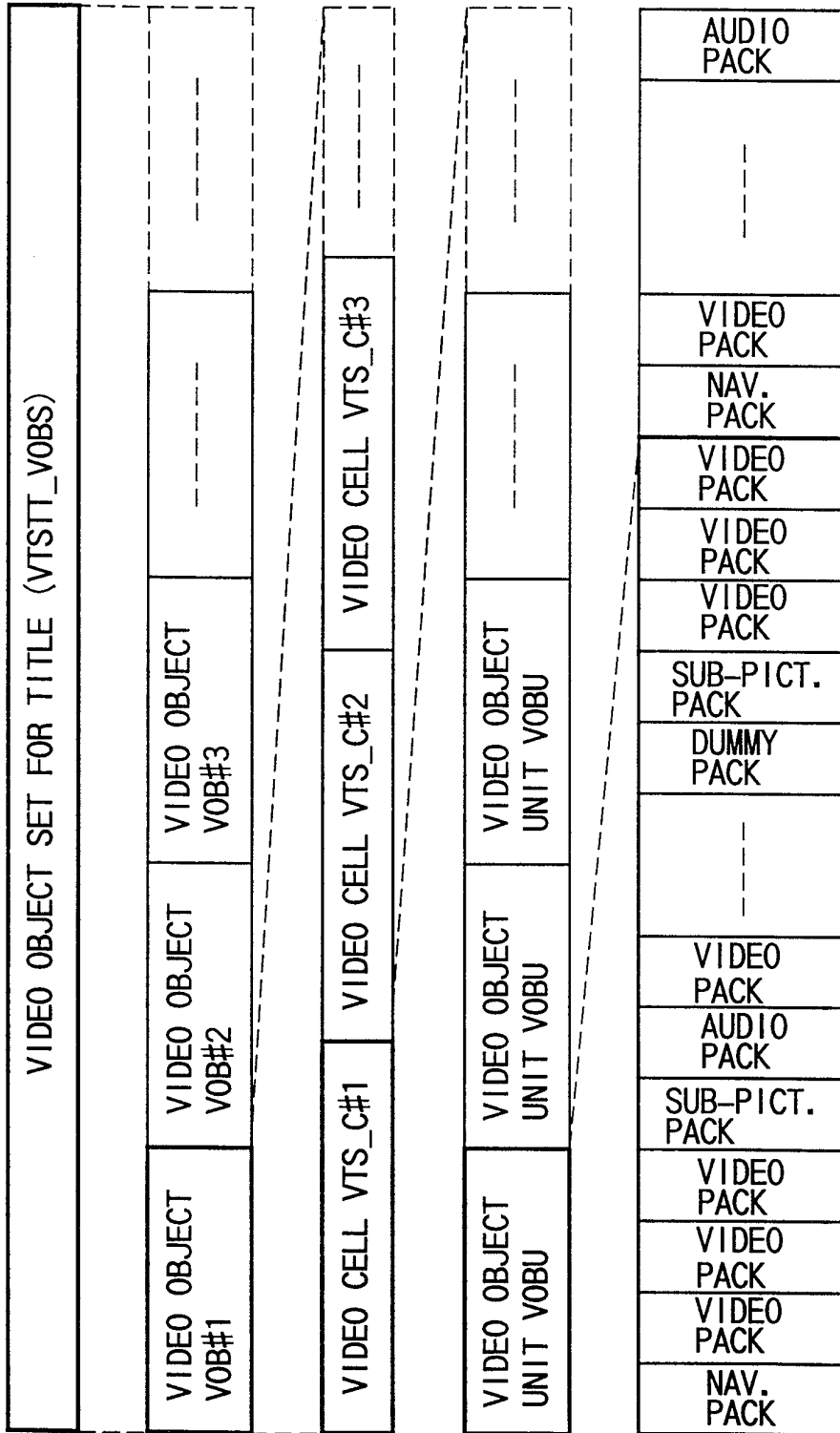

FIG. 8

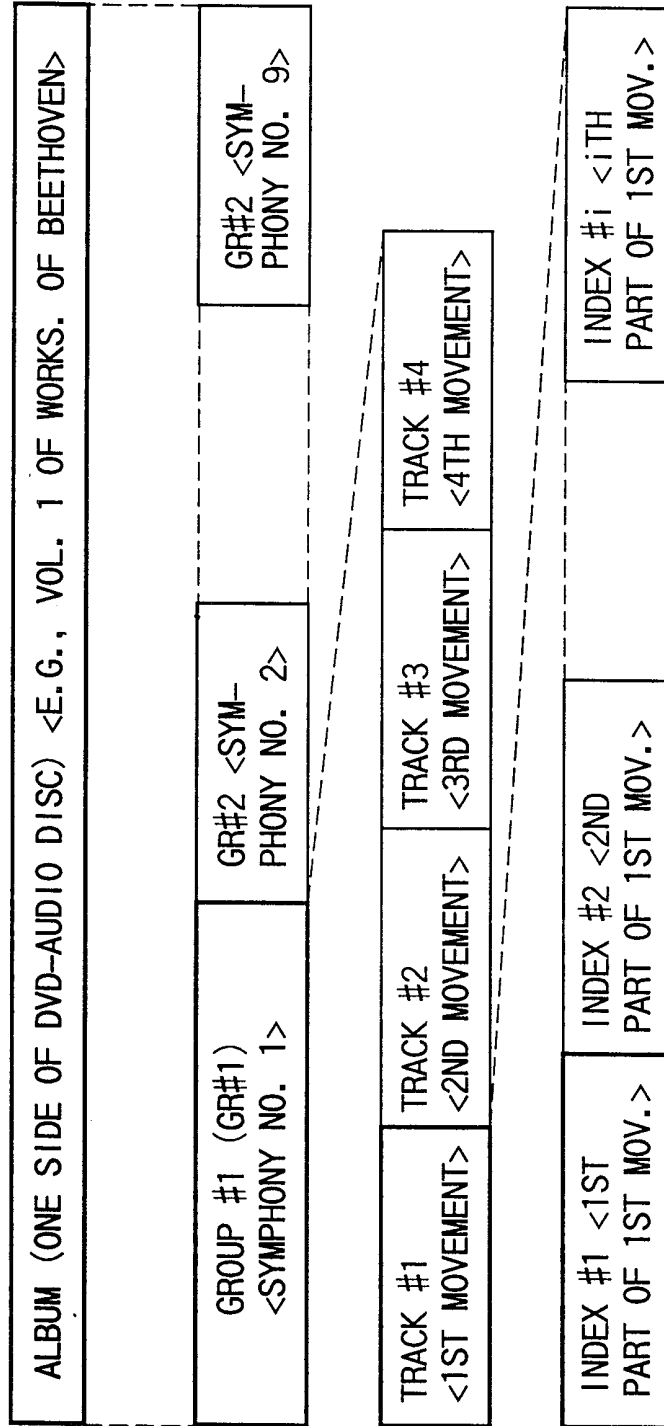

FIG. 9

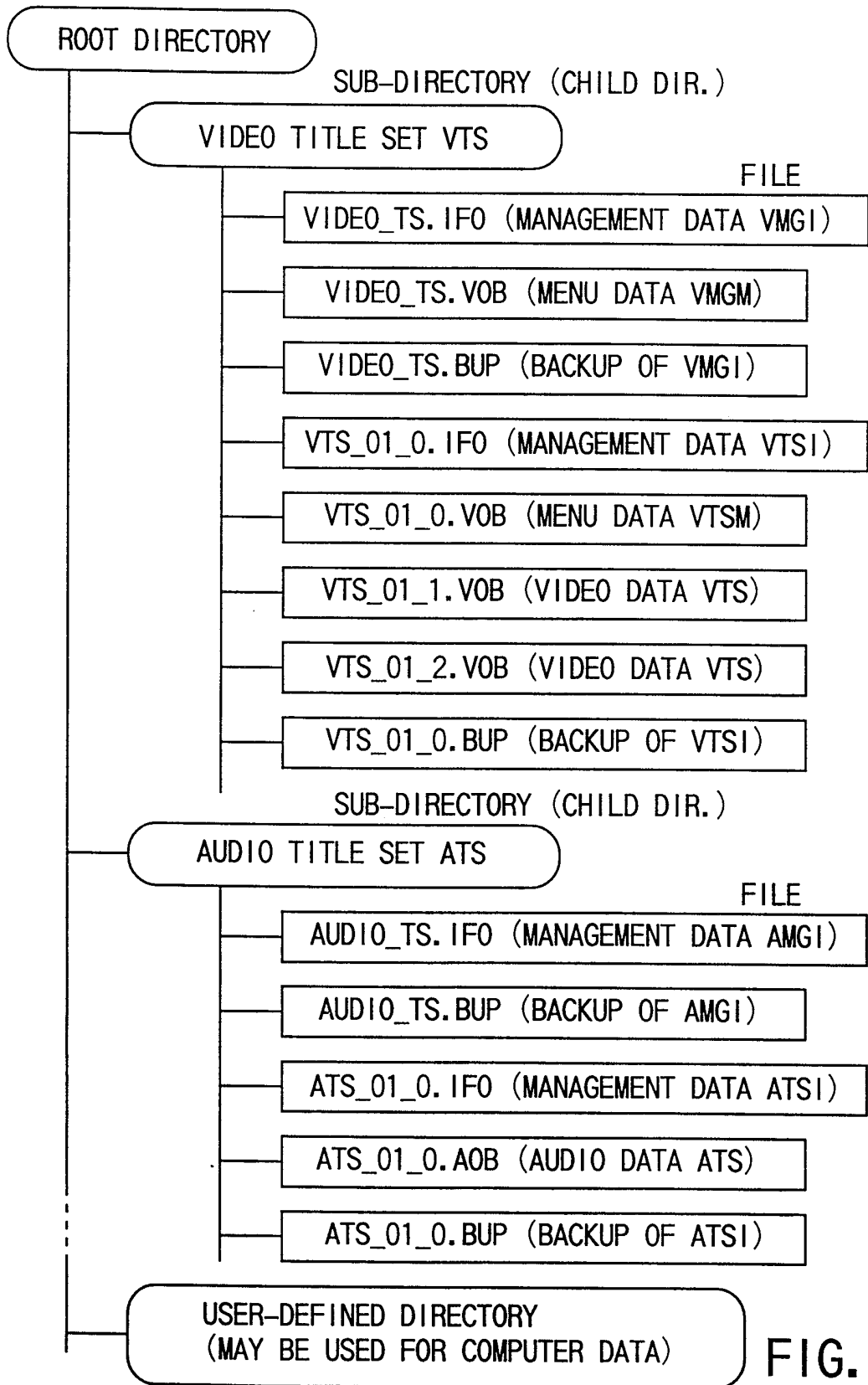

FIG. 10

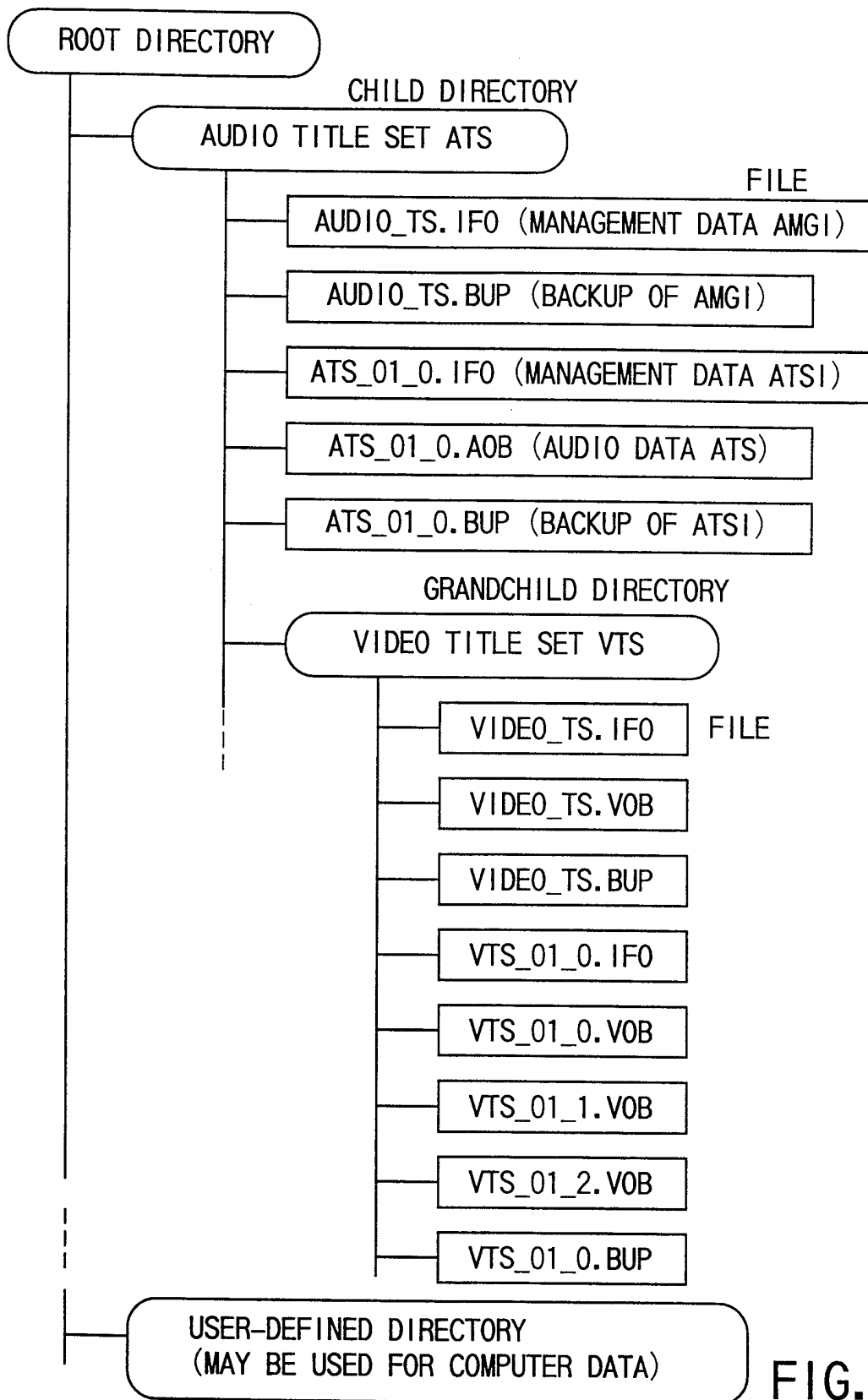

FIG. 11

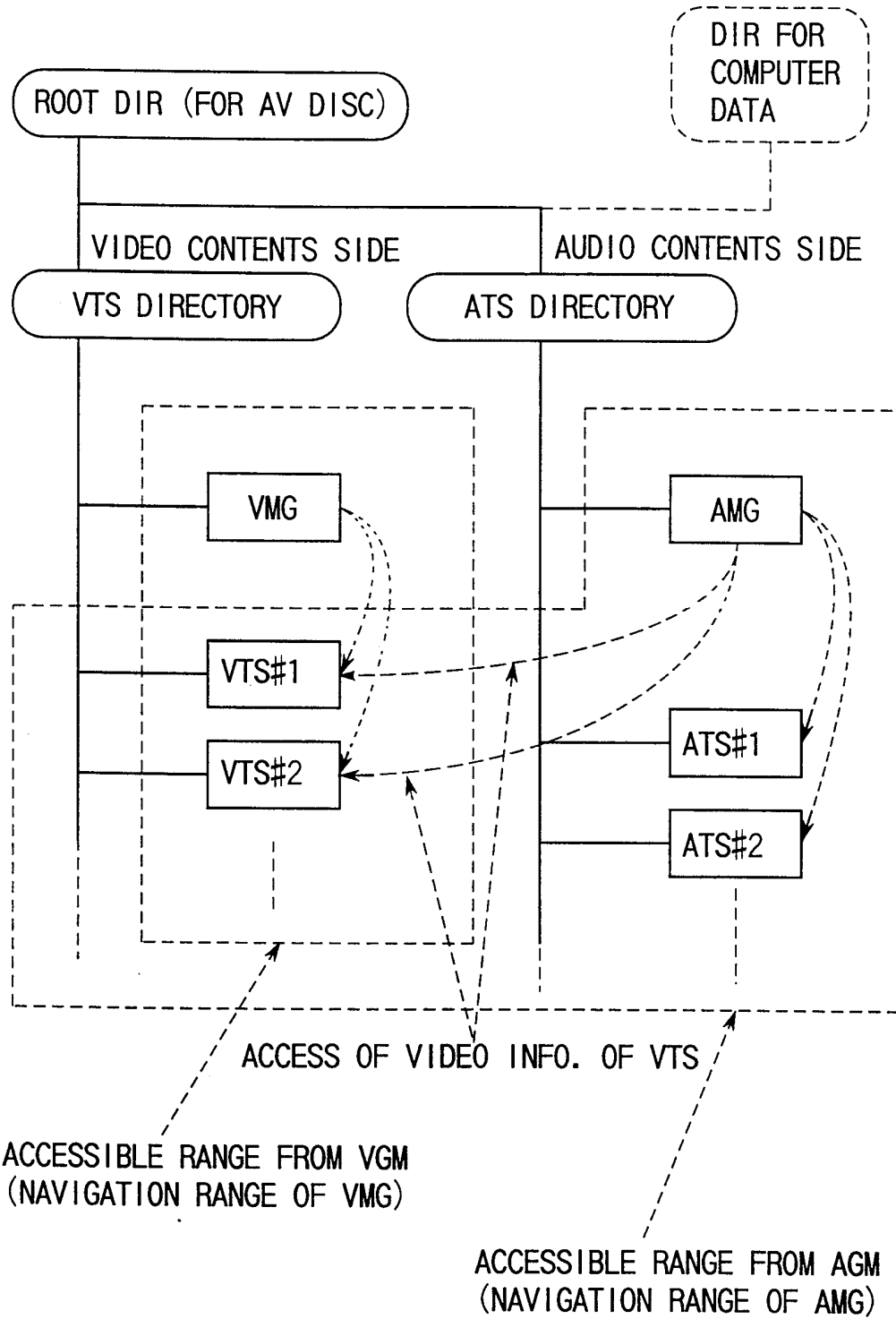

FIG. 12

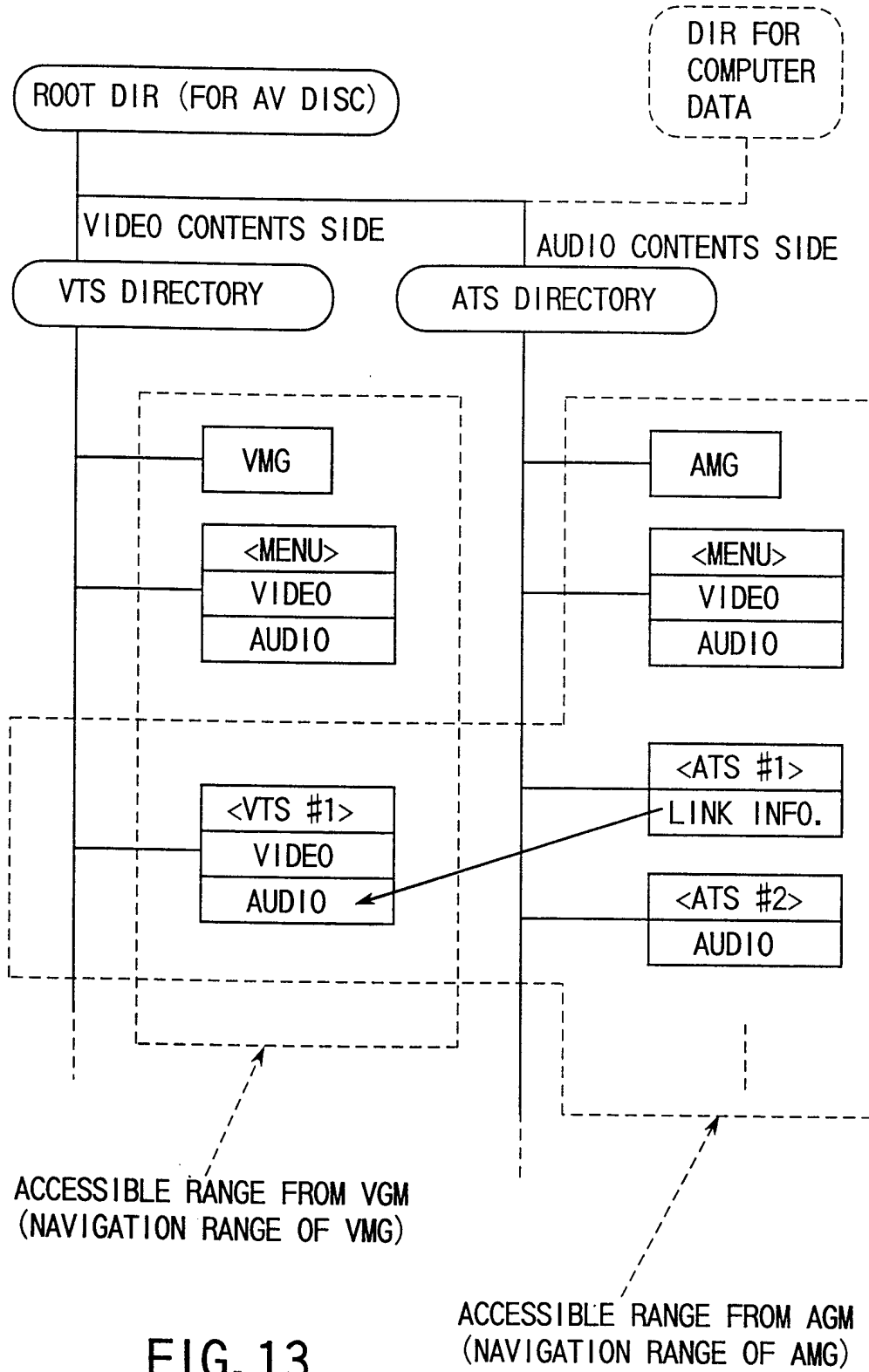

FIG. 13

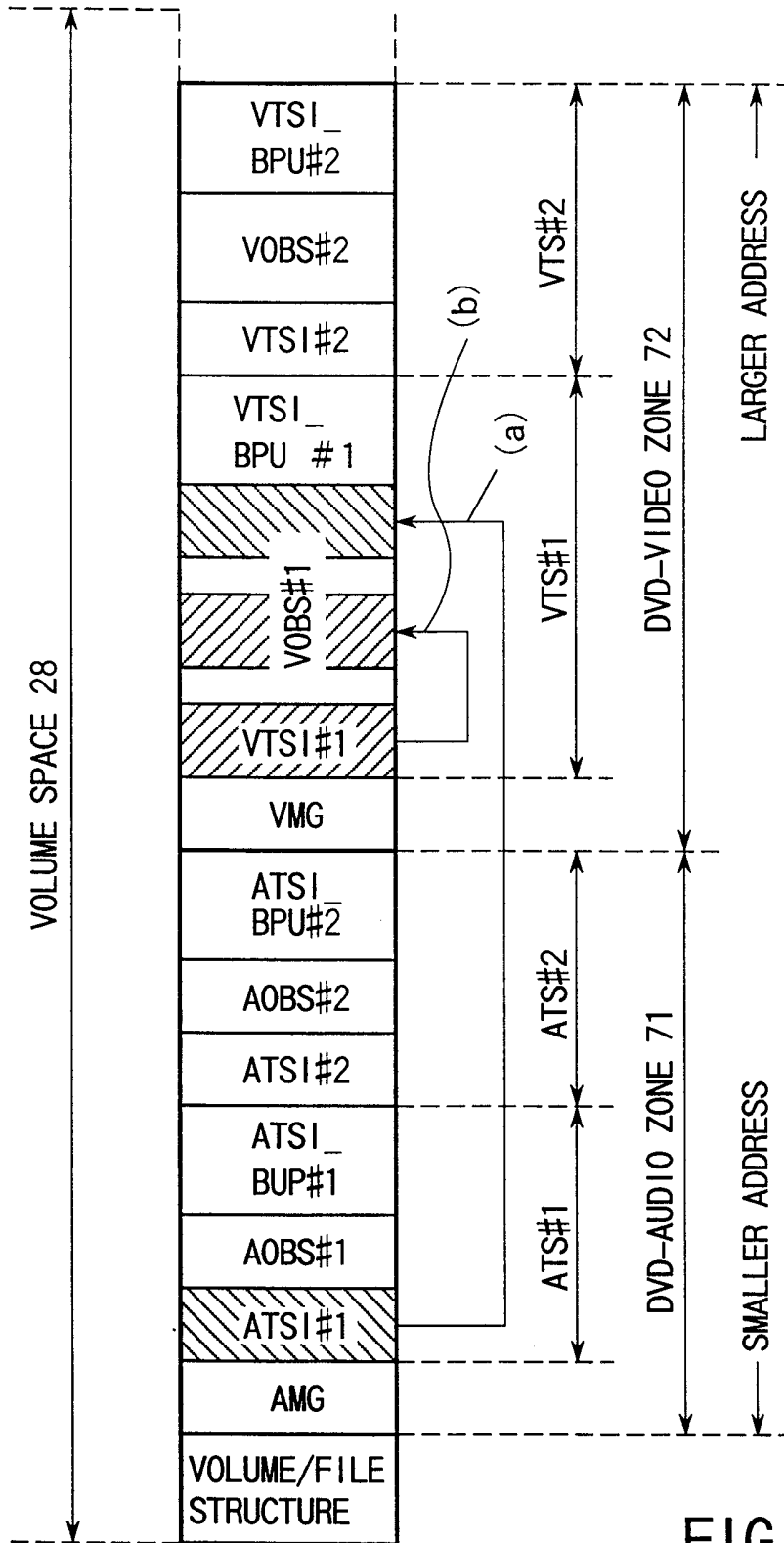

FIG. 14

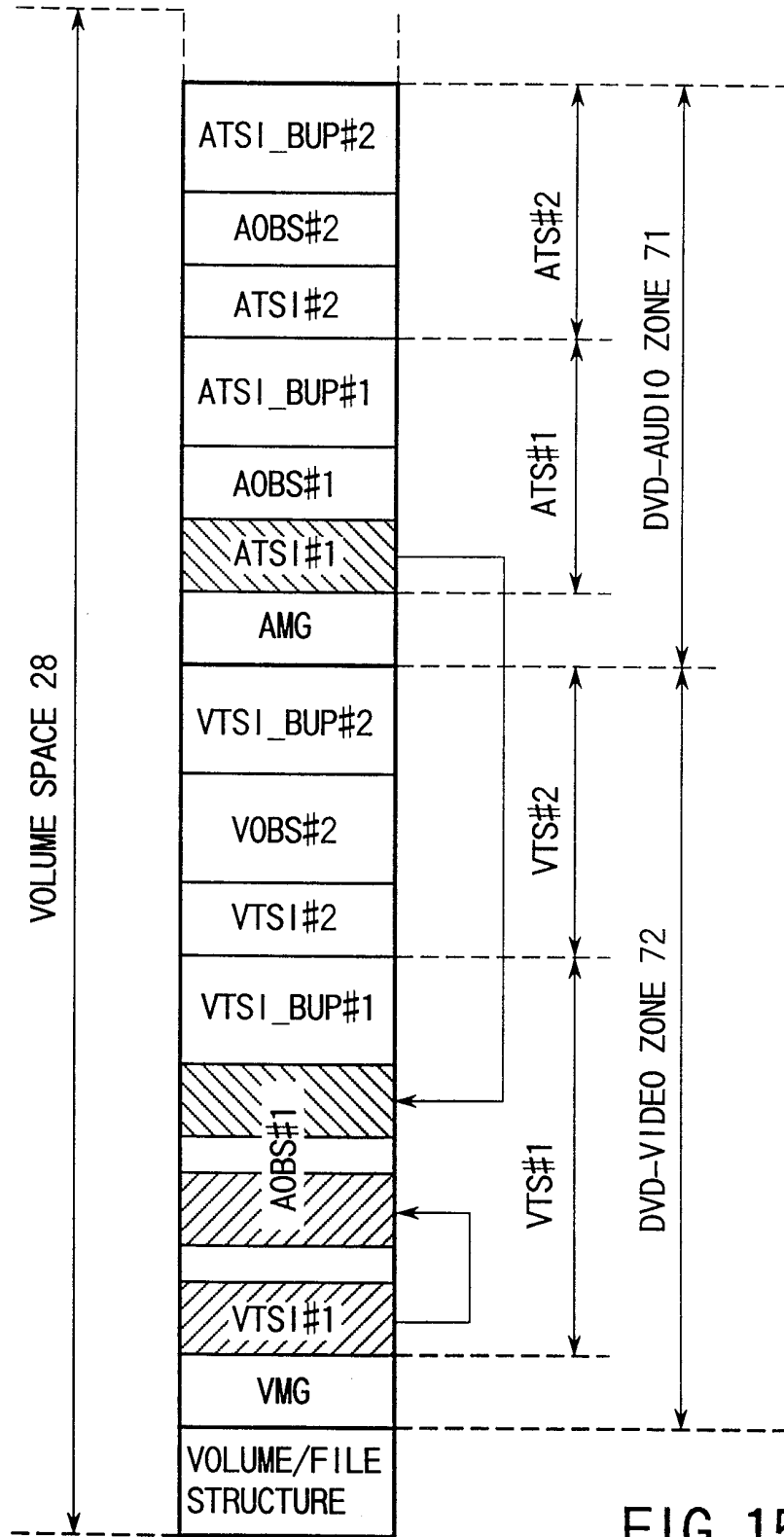

FIG. 15

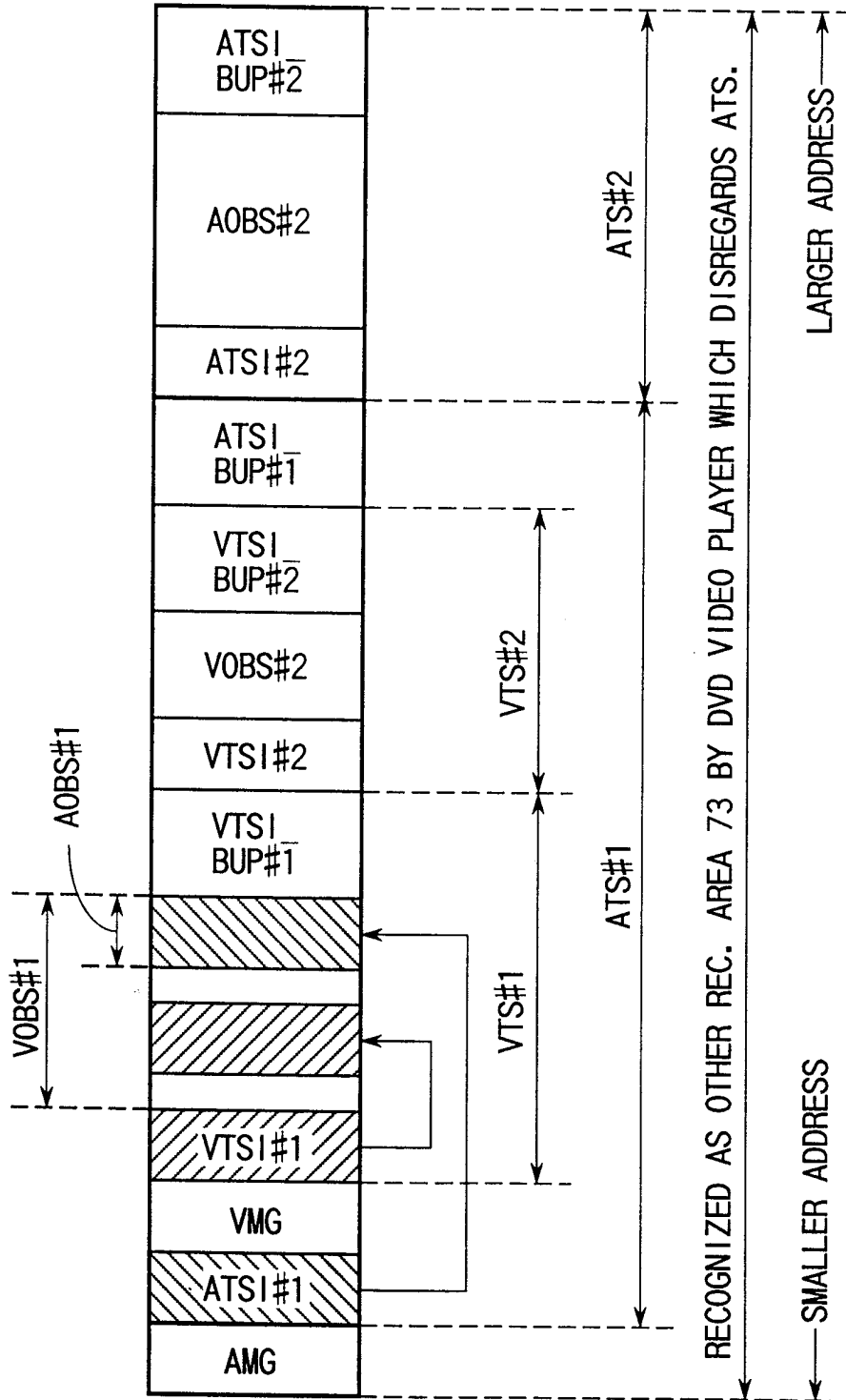

FIG. 16

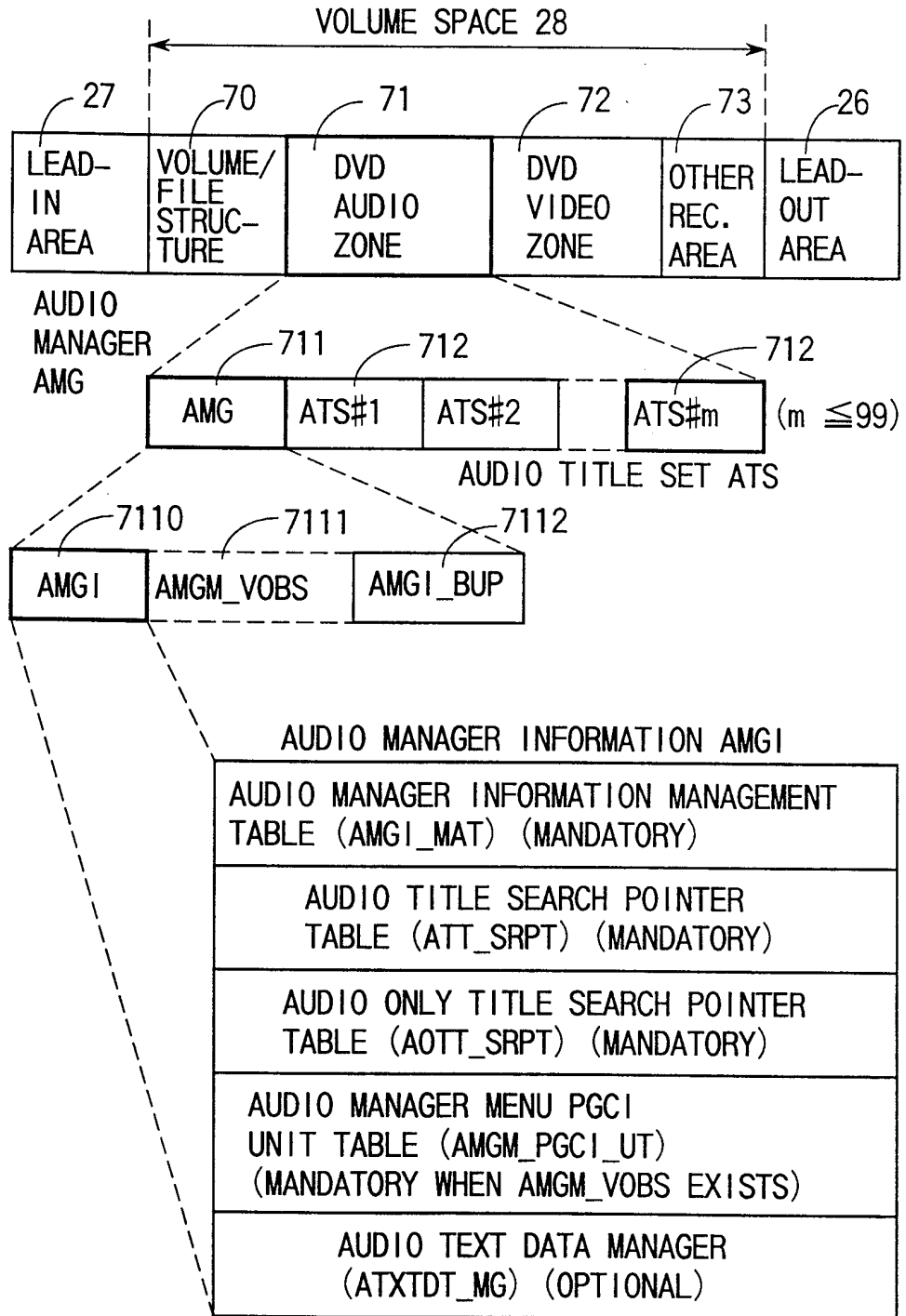

FIG. 17

AUDIO MANAGER INFORMATION MANAGEMENT TABLE AMGI\_MAT

RBP	SYMBOL/FILE NAME	CONTENTS	BYTES
0 - 11	AMG_ID	AMG IDENTIFIER	12
12 - 15	AMG_EA	END ADR. OF AMG	4
16 - 27	RESERVED	RESERVED	12
28 - 31	AMGI_EA	END ADR OF AMGI	4
32 - 33	VERN	VERSION NUMBER OF AUDIO SPEC.	2
34 - 37	RESERVED	RESERVED	4
38 - 45	VLMS_ID	VOLUME SET ID	8
46 - 47	AP_INF	AUTO PLAY INFO.	2
48 - 51	ASVS_SA	START ADR. OF ASVS	4
52 - 61	RESERVED	RESERVED	10
62 - 63	TS_Ns	NUMBER OF TITLE SETS	2
64 - 95	PVR_ID	PROVIDER UNIQUE ID	32
96 - 127	RESERVED	RESERVED	32
128 - 131	AMGI_MAT_EA	END ADR. OF AMGI_MAT	4
132 - 191	RESERVED	RESERVED	60
192 - 195	AMGM_VOBS_SA	START ADR. OF AMGM_VOBS	4
196 - 199	ATT_SRPT_SA	START ADR. OF ATT_SRPT	4
200 - 203	AOTT_SRPT_SA	START ADR. OF AOTT_SRPT	4
204 - 207	AMGM_PGCI_UT_SA	START ADR. OF AMGM_PGCI_UT	4
208 - 211	RESERVED	RESERVED	4
212 - 215	ATXTDT_MG_SA	START ADR. OF ATXTDT_MG	4
216 - 255	RESERVED	RESERVED	40
256 - 257	AMGM_V_ATR	VIDEO ATTRIB. OF AMGM_VOBS	2
258 - 339	RESERVED	RESERVED	82
340 - 341	AMGM_SPST_Ns	NUMBER OF SUB-PICT. STREAMS FOR AMGM	2
342 - 347	AMGM_SPST_ATR	SP ATTRIB. OF AMGM_VOBS	6
348 - 349	AMGM_AST_Ns	AUDIO STREAM NO.	2
350 - 357	AMGM_AST_ATR	AUDIO STREAM ATTRIB.	8
358 - 2047	RESERVED	RESERVED	1690
		TOTAL BYTES	2048

RBP=RELATIVE BYTE POSITIONS

FIG. 18

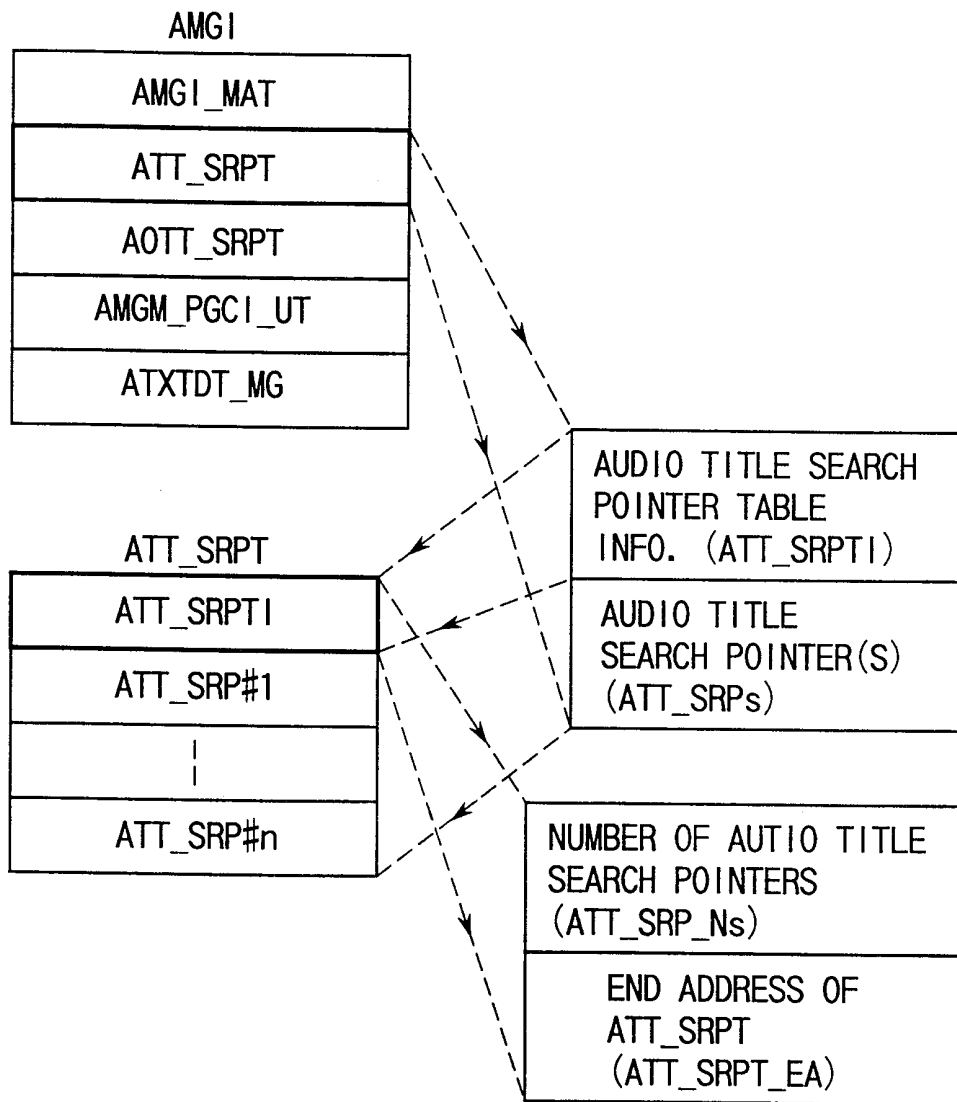

FIG. 19

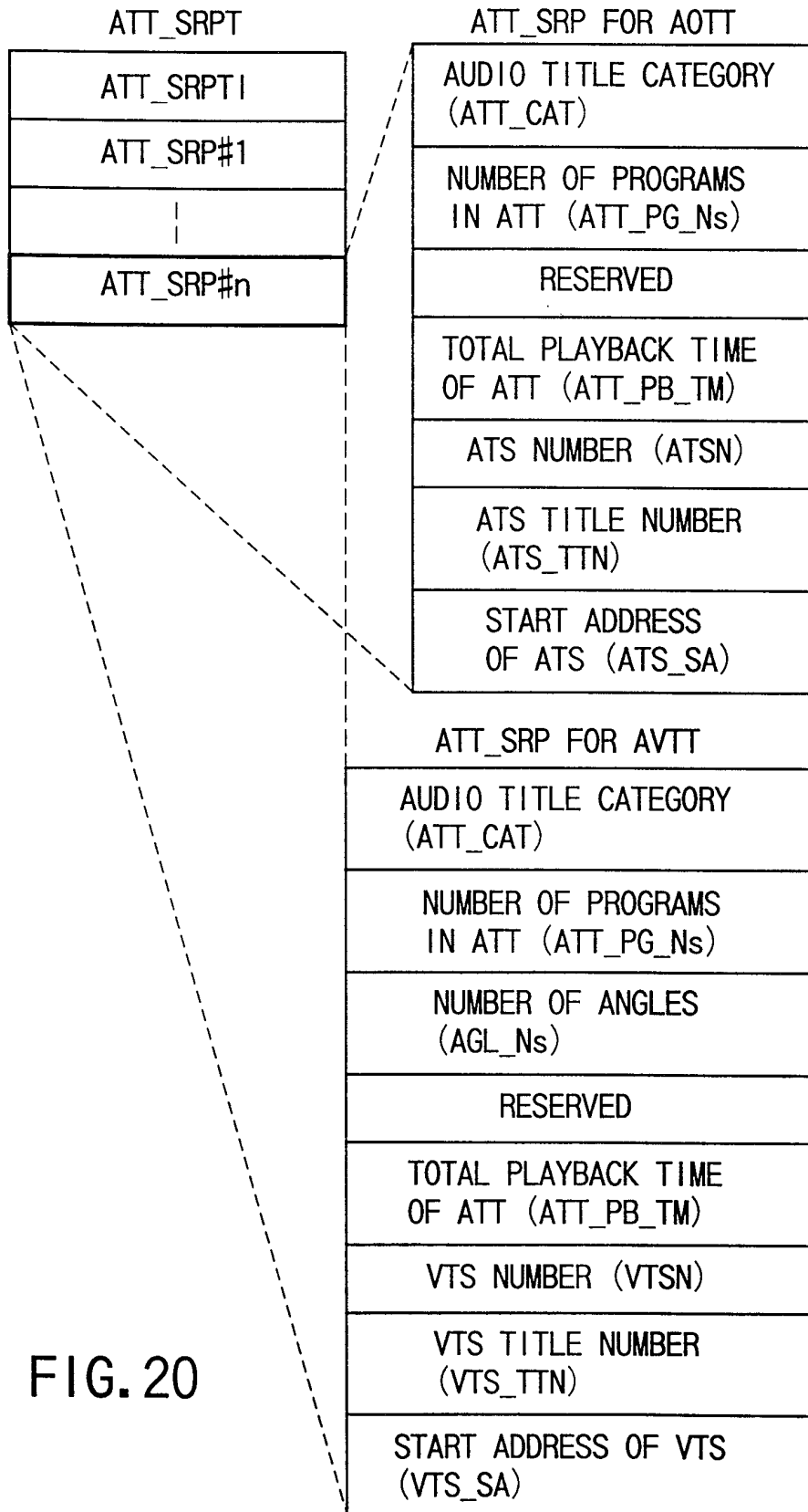

FIG. 20

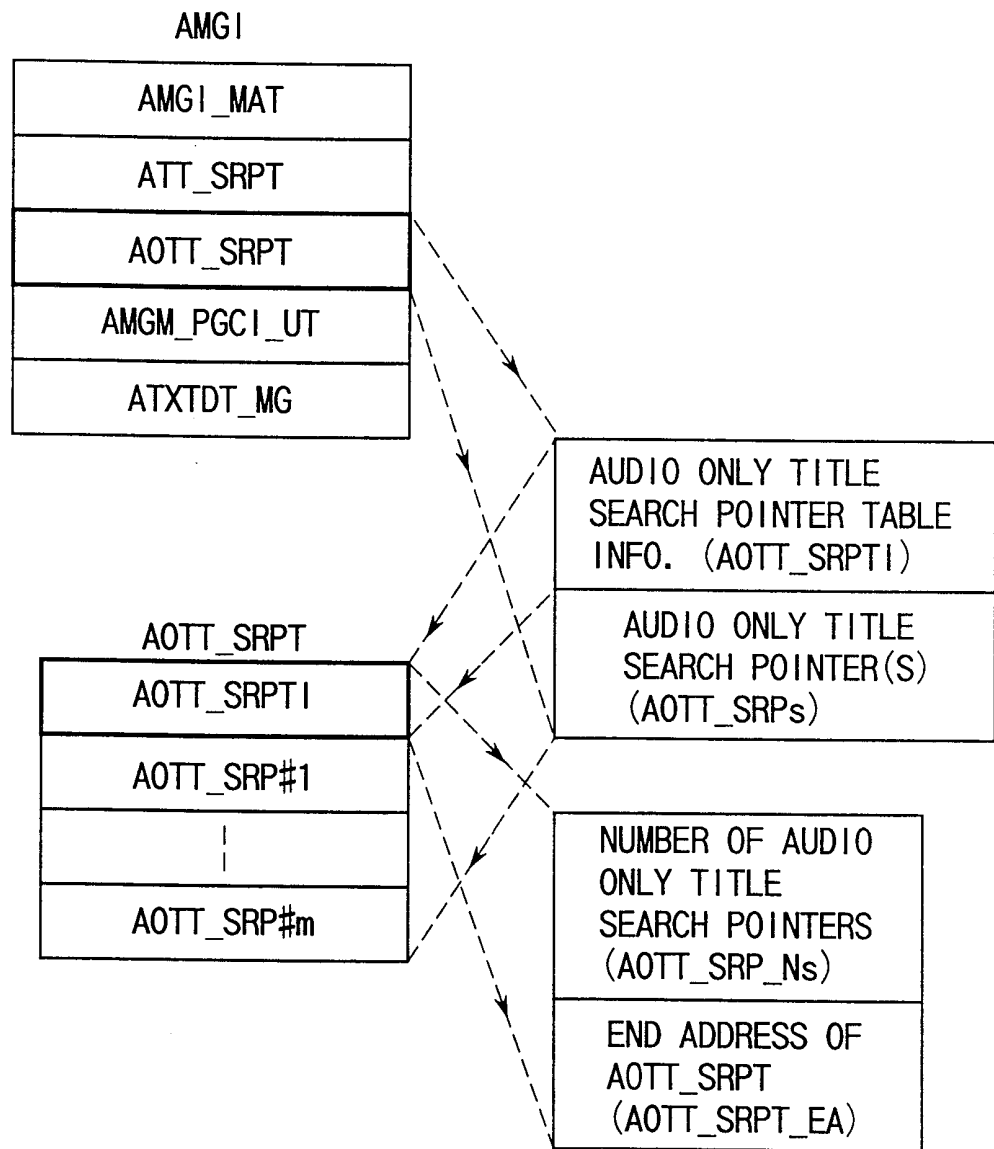

FIG. 21

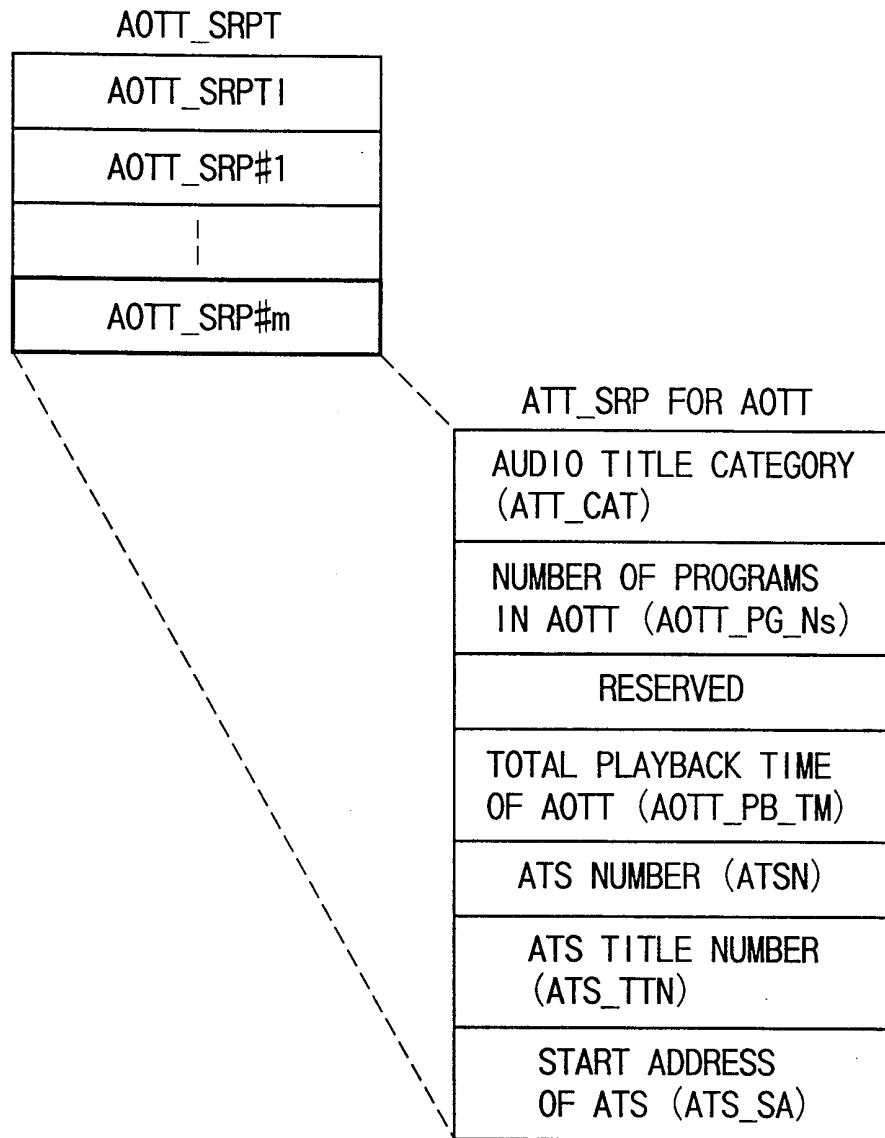

FIG. 22

NUMBER OF ATT	CONTENTS OF ATT	GROUP OF AOTT (AOTT_GR)		GROUP OF ATT (ATT_GR)	
		AOTT_SRPT	AOTT_GR NO.	ATT_SRPT	ATT_GR NO.
#1	AVTT	NONE	—	FOR AVTT	GR#1
#2	AVTT&AOTT	FOR AOTT	GR#1	FOR AVTT	GR#2
#3	AVTT&AOTT	FOR AOTT		FOR AVTT	
#4	AOTT	FOR AOTT		FOR AOTT	
#5	AOTT	FOR AOTT	GR#2	FOR AOTT	GR#3
#6	AVTT&AOTT	FOR AOTT		FOR AVTT	
#7	AOTT	FOR AOTT		FOR AOTT	
#8	AOTT	FOR AOTT		FOR AOTT	
#9	AVTT	NONE	—	FOR AVTT	GR#4

FIG. 23

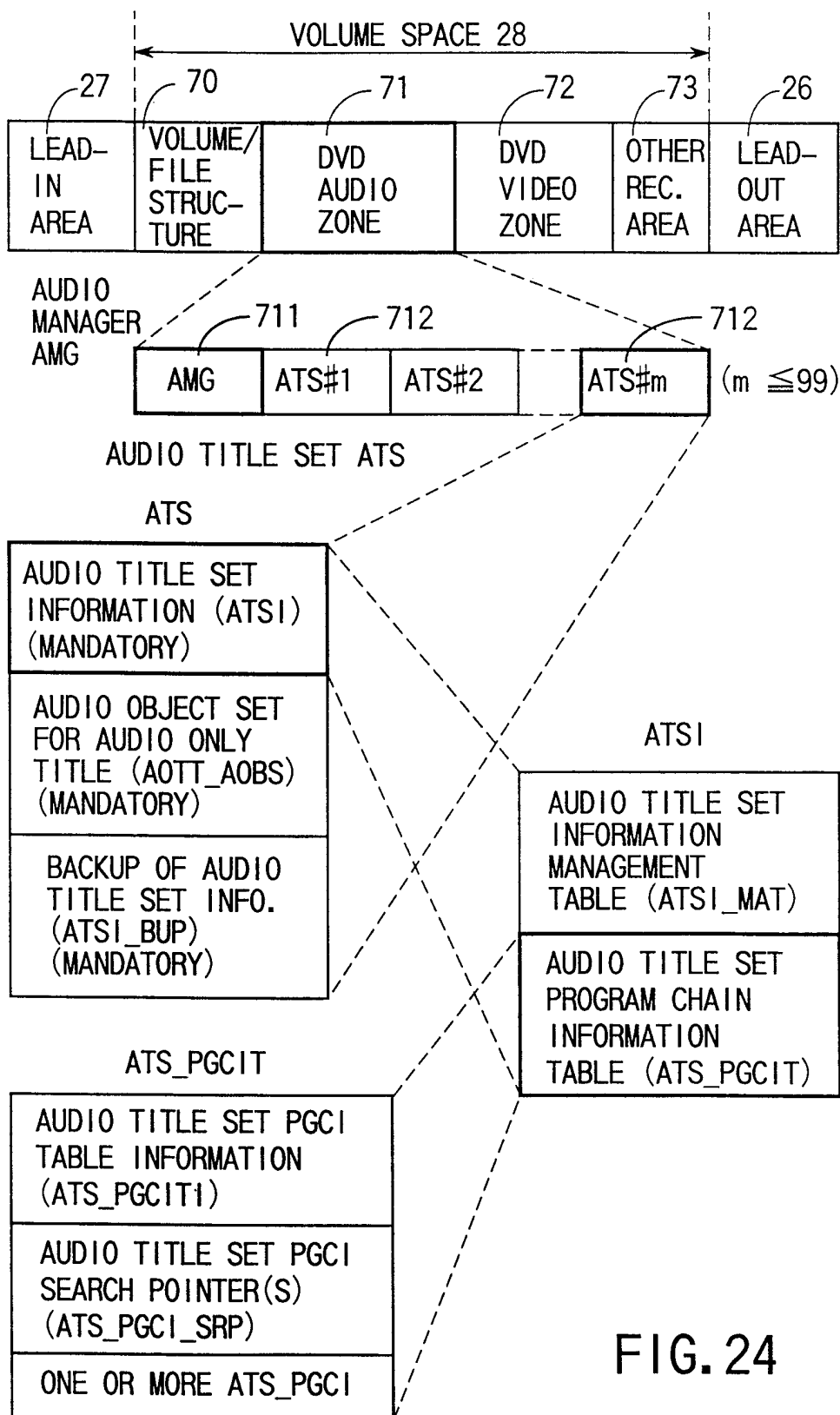

FIG. 24

AUDIO TITLE SET INFORMATION MANAGEMENT TABLE ATSI\_MAT

RBP	SYMBOL/FILE NAME	CONTENTS	BYTES	
0 - 11	ATS_ID	ATS IDENTIFIER	12	
12 - 15	ATS_EA	END ADR. OF ATS	4	
16 - 27	RESERVED	RESERVED	12	
28 - 31	ATSI_EA	END ADR OF ATSI	4	
32 - 33	VERN	VERSION NUMBER OF AUDIO SPEC.	2	
34 - 127	RESERVED	RESERVED	94	
128 - 131	ATSI_MAT_EA	END ADDRESS OF ATSI_MAT	4	
132- 191	RESERVED	RESERVED	60	
192 - 195	VTS_SA	START ADDRESS OF VTS FOR AOTT	4	
196 - 199	AOTT_AOBS_SA/ ----- AOTT_VOBS_SA	START ADDRESS OF AOBs FOR AOTT, OR START ADDRESS OF VOBs FOR AOTT	4	
200 - 203	RESERVED	RESERVED	4	
204 - 207	ATS_PGCIT_SA	START ADDRESS OF ATS_PGCIT	4	
208 - 255	RESERVED	RESERVED	48	
256-383	AOTT_AOB_ATR/ ----- AOTT_VOB_ART ----- (#0~#7)	ATTRIB. OF AOBs FOR AOTT, OR ATTRIB. OF AUDIO STREAM OF VOBs FOR AOTT	128	
384-671	ATS_DM_COEFT ----- (#0~#15)	COEFFICIENTS TO MIX DOWN AUDIO DATA WITH MULTI-CHANNEL OUTPUT TO 2-CHANNEL OUTPUT	288	
672 - 2047	RESERVED	RESERVED	1376	
RBP=RELATIVE BYTE POSITION			TOTAL BYTES	2048

FIG. 25

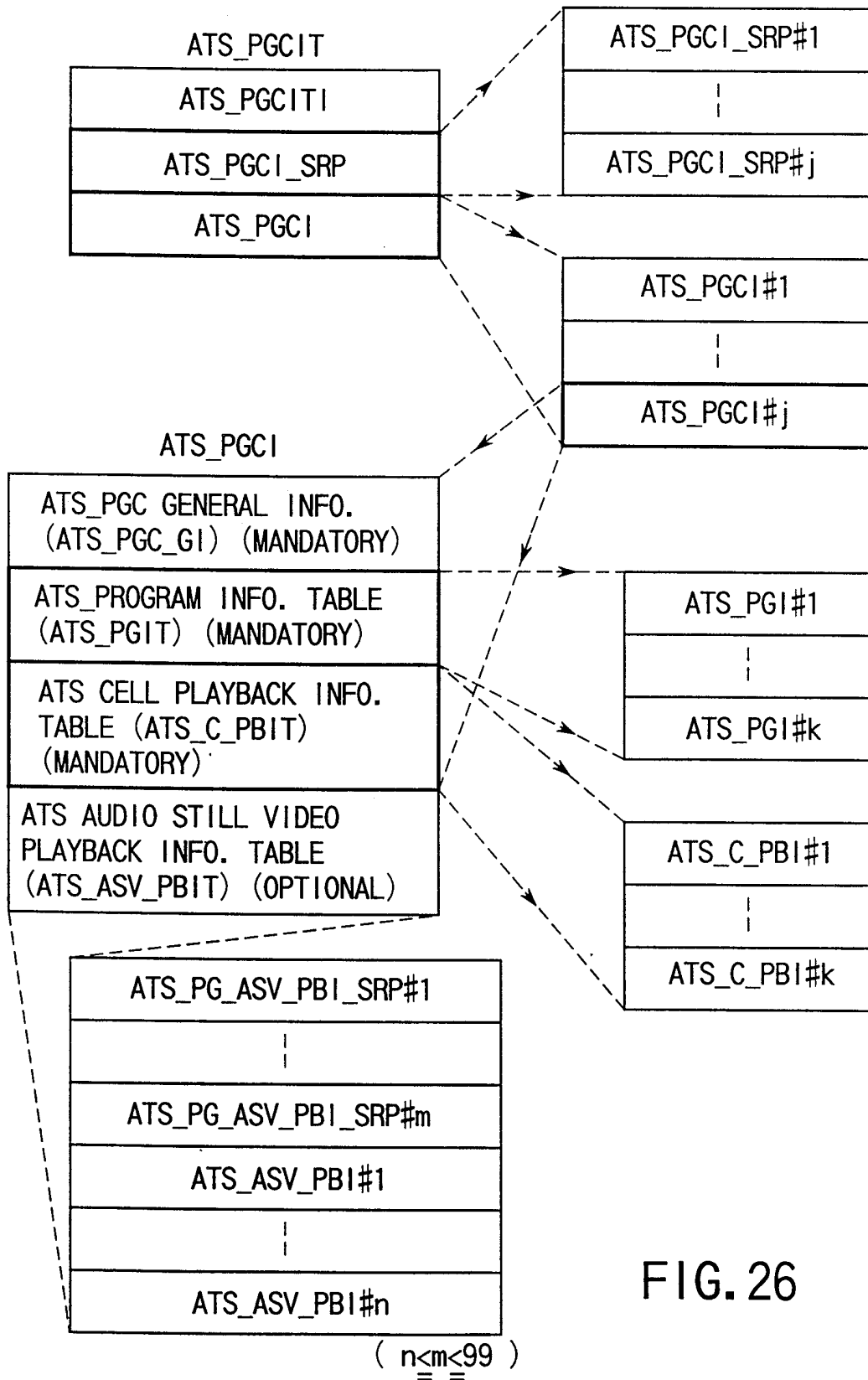

FIG. 26

AUDIO TITLE SET PROGRAM INFORMATION ATS\_PG1

RBP	SYMBOL/FILE NAME	CONTENTS	BYTES
0-3	ATS_PG_CNT	ATS_PG CONTENTS	4
4	ATS_PG_EN_CN	ENTRY CELL NUMBER OF ATS_PG	1
5	RESERVED	RESERVED	1
6-9	FAC_ST_PTM	START PRESENTATION TIME OF FIRST AUDIO CELL IN ATS_PG	4
10-13	ATS_PG_PB_TM	ATS_PG PLAYBACK TIME	4
14-17	ATS_PG_PA_TM	ATS_PG PAUSE TIME	4
18	RESERVED	RESERVED	1
19	RESERVED	RESERVED	1

RBP=RELATIVE BYTE POSITIONS

FIG. 27

AUDIO TITLE SET CELL PLAYBACK INFORMATION ATS\_C\_PBI

RBP	SYMBOL/FILE NAME	CONTENTS	BYTES
0	ATS_C_IXN	INDEX NO. OF ATS_C	1
1	ATS_C_TY	ATS_C TYPE	1
2-3	RESERVED	RESERVED	2
4-7	ATS_C_SA	START ADDRESS OF ATS_C	4
8-11	ATS_C_EA	END ADDRESS OF ATS_C	4

RBP=RELATIVE BYTE POSITIONS

FIG. 28

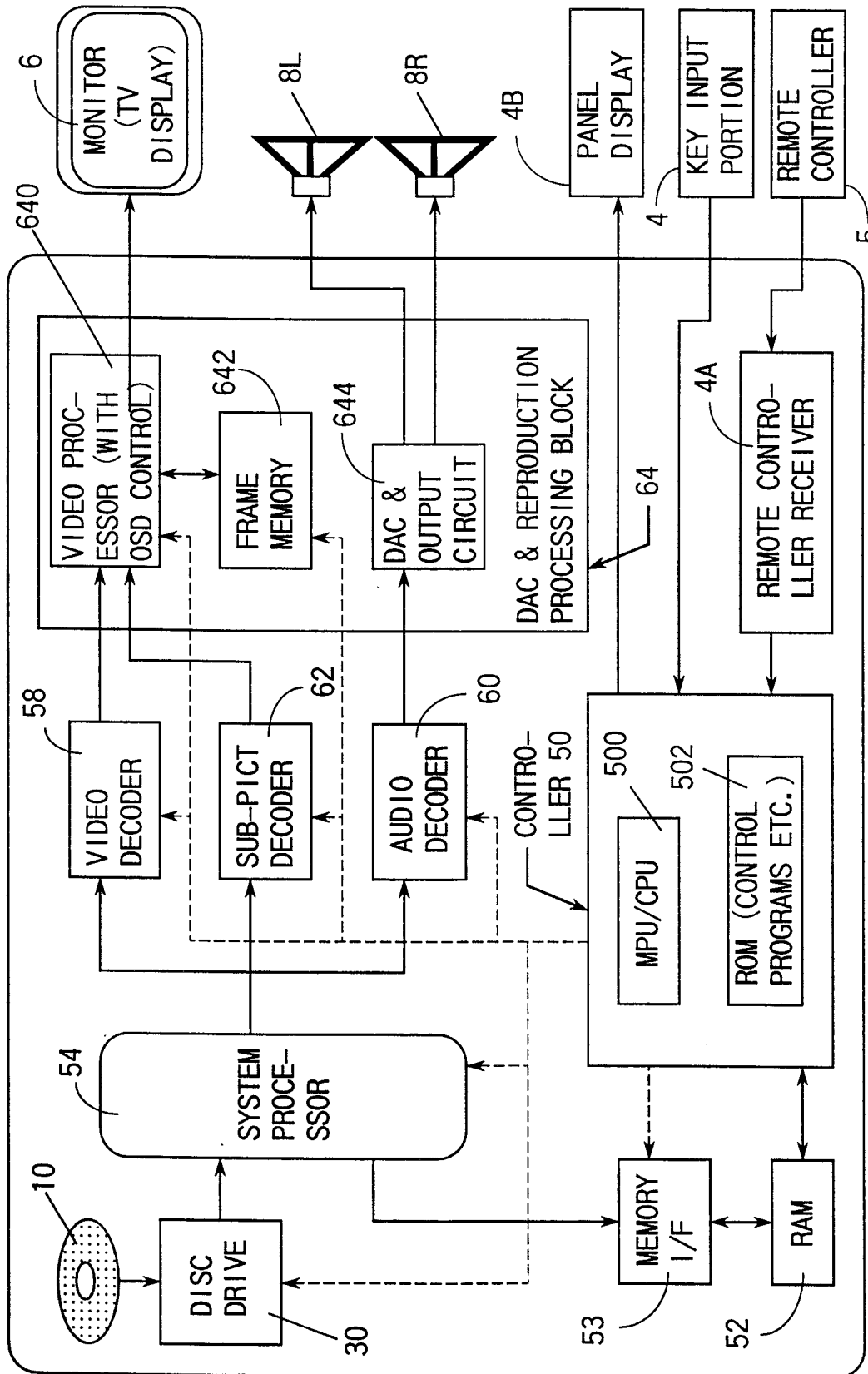

FIG. 29

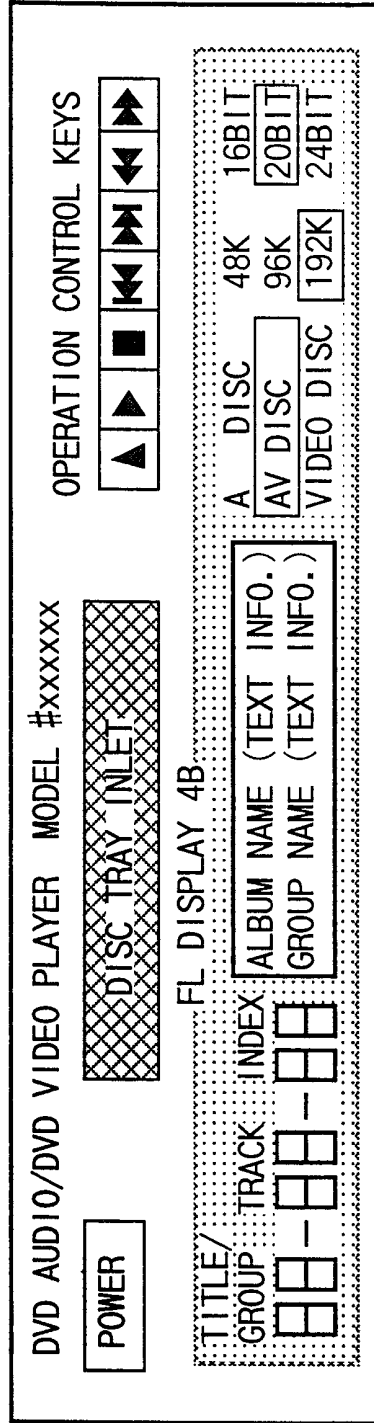

FIG. 30

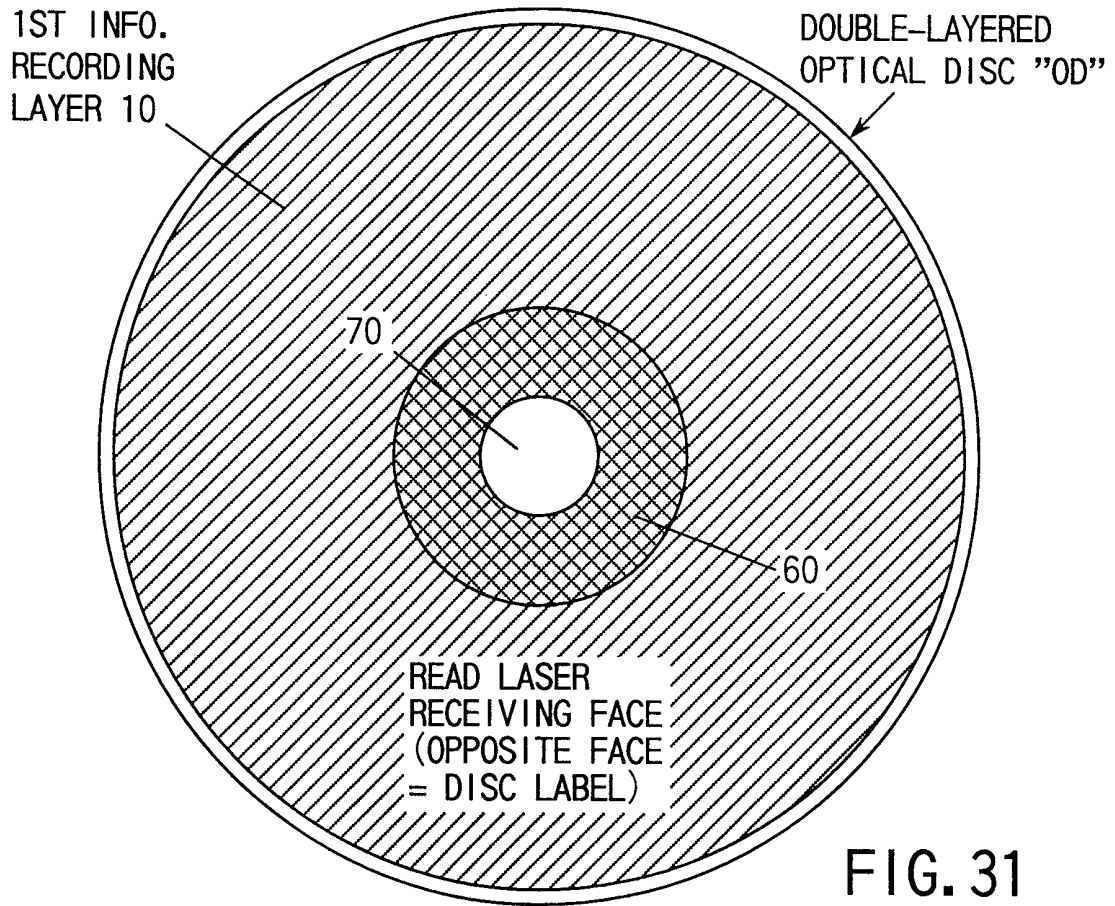

FIG. 31

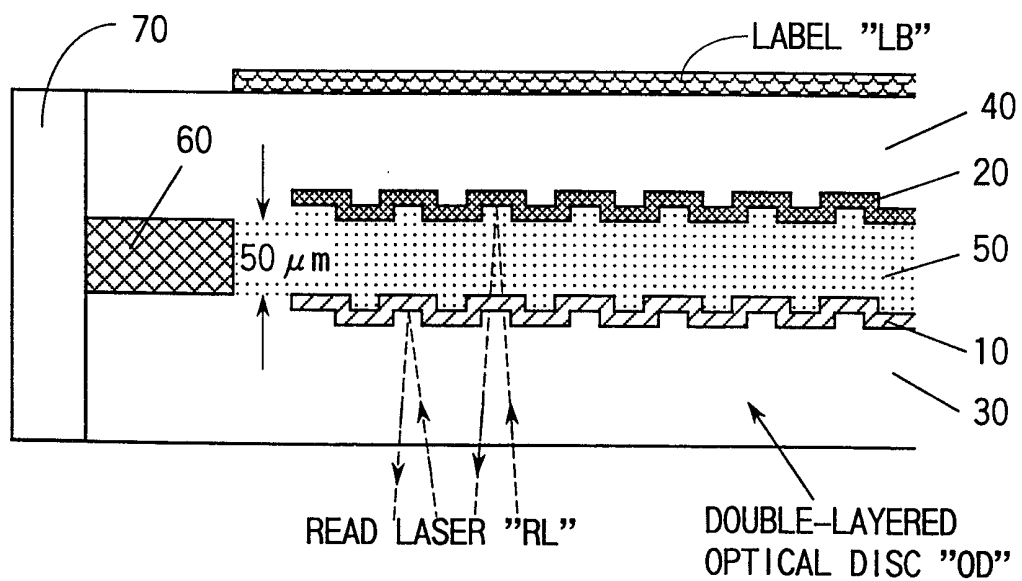

FIG. 32

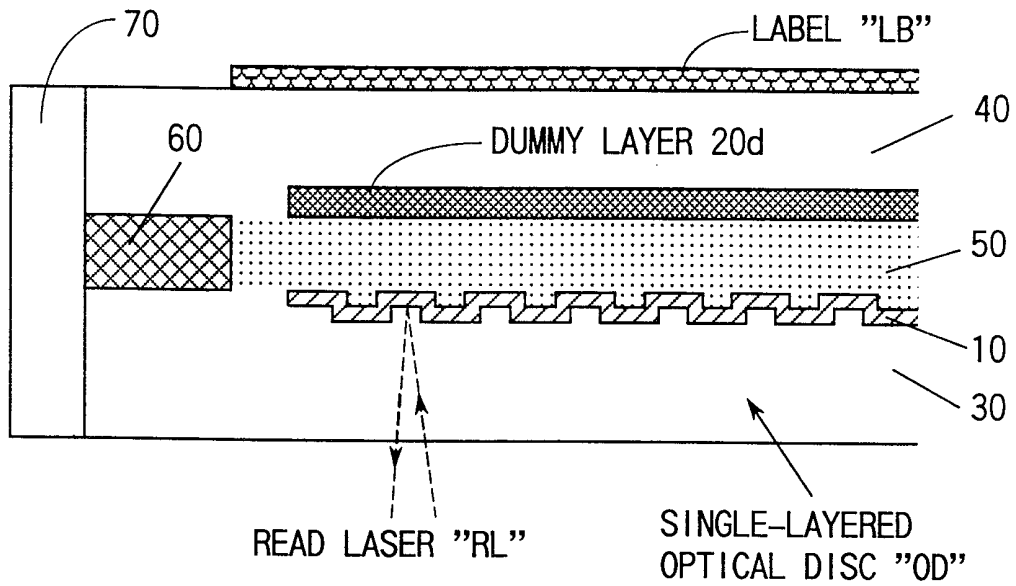

FIG. 33

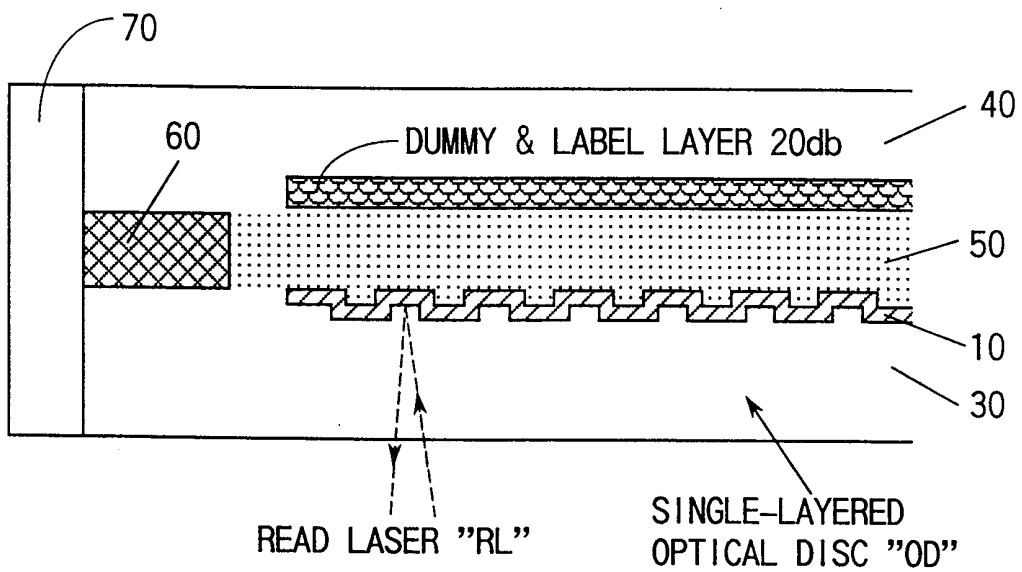
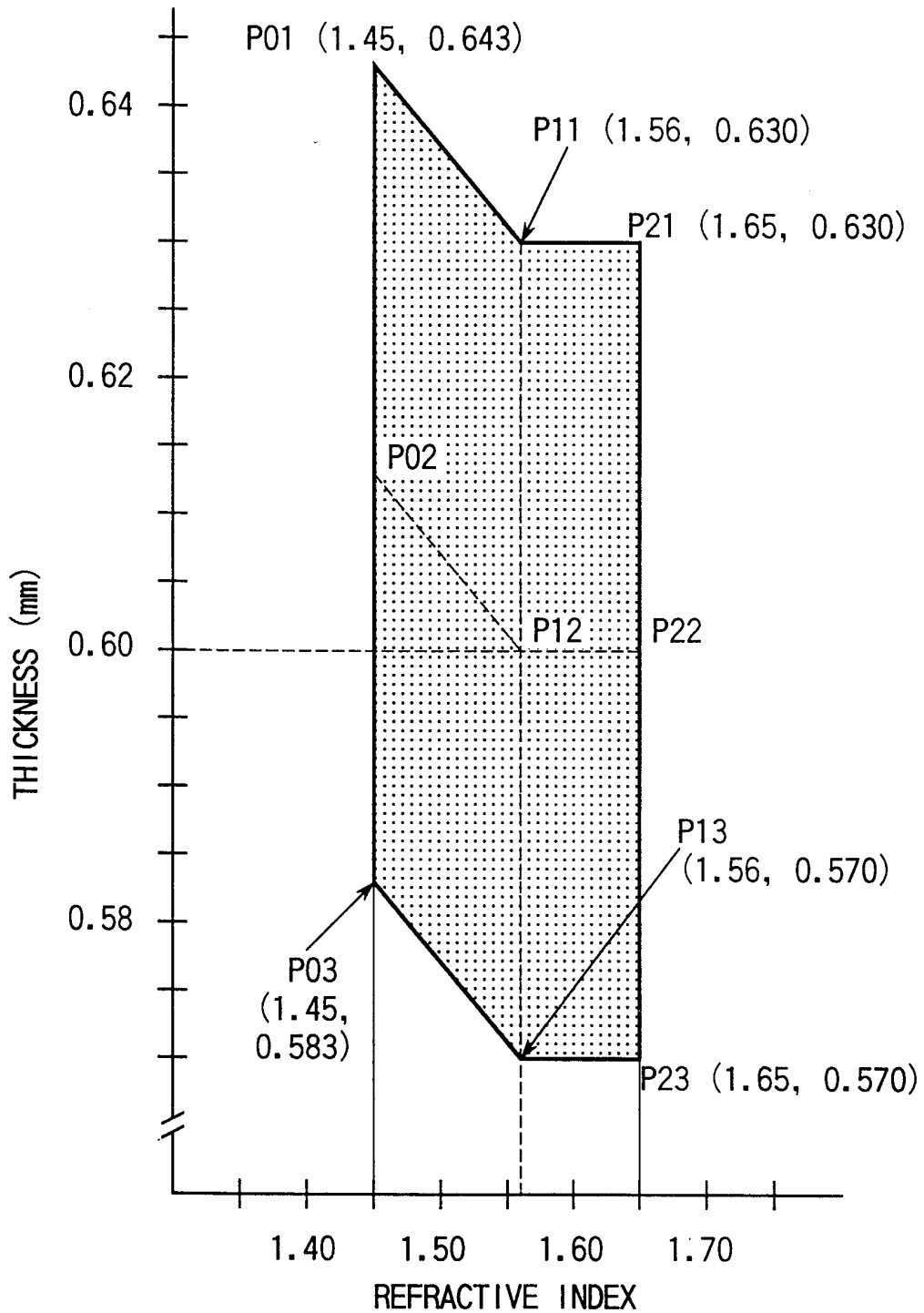
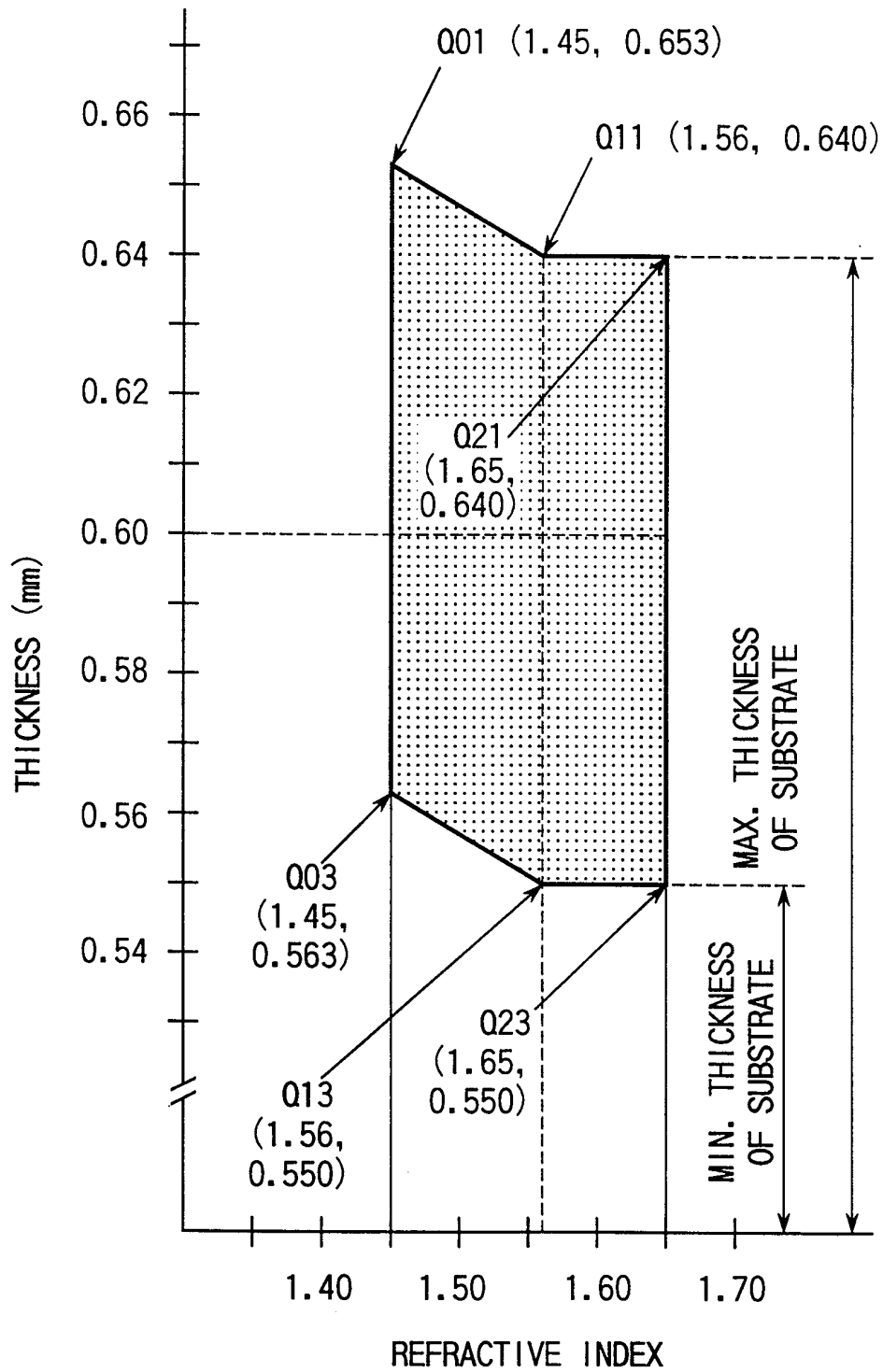

FIG. 34



SUBSTRATE THICKNESS AS A FUNCTION OF REFRACTIVE INDEX FOR SINGLE LAYERED SIDE

FIG. 35



THICKNESS OF SUBSTRATE/SPACE LAYER AS A FUNCTION OF REFRACTIVE INDEX FOR DUAL LAYERED SIDE

FIG. 36