



US00D728640S

(12) **United States Design Patent**  
**Turner et al.**

(10) **Patent No.:** **US D728,640 S**

(45) **Date of Patent:** **\*\* May 5, 2015**

(54) **BONNET FOR WHEELED LOADING SHOVEL VEHICLE**

(71) Applicant: **J.C. Bamford Excavators Limited,**  
Uttoxeter (GB)

(72) Inventors: **Michael Turner,** Uttoxeter (GB); **Toby Mellor,** Uttoxeter (GB); **Jason Burgess,** Uttoxeter (GB); **Simon Davies,** Uttoxeter (GB); **Stuart Jones,** Uttoxeter (GB); **Juan Carlos Ramires,** Uttoxeter (GB); **John Boughton,** Uttoxeter (GB)

(73) Assignee: **J.C. Bamford Excavators Limited,**  
Uttoxeter (GB)

(\*\*) Term: **14 Years**

(21) Appl. No.: **29/496,170**

(22) Filed: **Jul. 10, 2014**

(30) **Foreign Application Priority Data**

Jan. 10, 2014 (EM) ..... 001399273

(51) **LOC (10) Cl.** ..... **15-03**

(52) **U.S. Cl.**  
USPC ..... **D15/31**

(58) **Field of Classification Search**  
USPC ..... D15/10, 22-26, 28, 31, 33; 37/455,  
37/442, 443, 403, 409; 180/89.1, 89.12,  
180/298, 900, 68.5; 414/685, 694, 722, 724  
See application file for complete search history.

(56) **References Cited**

**U.S. PATENT DOCUMENTS**

D500,056 S \* 12/2004 DeYoung et al. .... D15/33  
D517,096 S \* 3/2006 Landers et al. .... D15/28  
D590,846 S \* 4/2009 Kinsinger et al. .... D15/25  
D624,567 S \* 9/2010 Kelley ..... D15/33  
D626,153 S \* 10/2010 Gavin et al. .... D15/31

D632,313 S \* 2/2011 Kelley ..... D15/33  
D633,927 S \* 3/2011 Kelley ..... D15/33  
D652,061 S \* 1/2012 Hiraoka et al. .... D15/23  
D652,062 S \* 1/2012 Hiraoka et al. .... D15/23  
D693,853 S \* 11/2013 Hiraoka et al. .... D15/23

\* cited by examiner

*Primary Examiner* — Mark Goodwin

(74) *Attorney, Agent, or Firm* — Marshall, Gerstein & Borun LLP

(57) **CLAIM**

The ornamental design for a bonnet for a wheeled loading shovel vehicle, as shown and described.

**DESCRIPTION**

FIG. 1 is a front, right-side, and top isometric view of a bonnet for a wheeled loading shovel vehicle that has the new design. FIG. 2 is a top plan view of the bonnet for a wheeled loading shovel vehicle.

FIG. 3 is a left-side elevation view of the bonnet for a wheeled loading shovel vehicle.

FIG. 4 is a rear elevation view of the bonnet for a wheeled loading shovel vehicle.

FIG. 5 is a front elevation view of the bonnet for a wheeled loading shovel vehicle.

FIG. 6 is a right-side elevation view of the bonnet for a wheeled loading shovel vehicle.

FIG. 7 is a bottom plan view of the bonnet for a wheeled loading shovel vehicle.

FIG. 8 is a front, left-side, and top isometric view of the bonnet for a wheeled loading shovel vehicle.

FIG. 9 is a back, right-side, and top isometric view of the bonnet for a wheeled loading shovel vehicle; and,

FIG. 10 is a back, left-side, and top isometric view of the bonnet for a wheeled loading shovel vehicle.

The broken lines represent elements of the bonnet for a wheeled loading shovel vehicle that form no part of the claimed design.

**1 Claim, 7 Drawing Sheets**

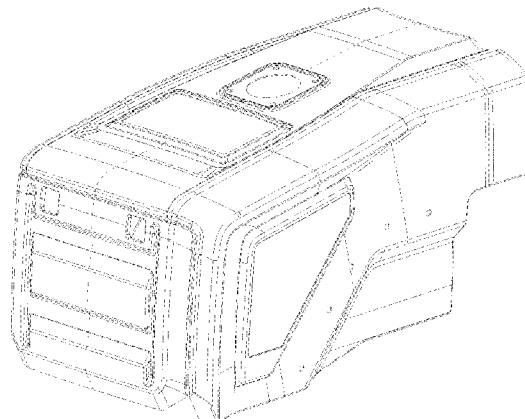

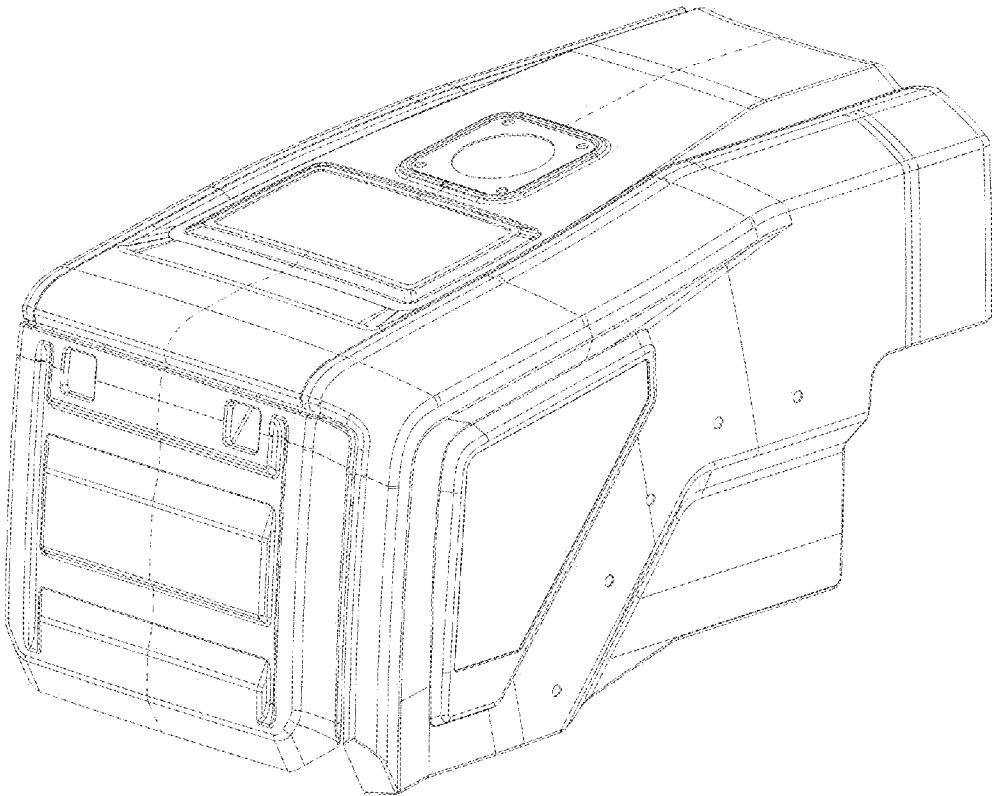

FIG. 1

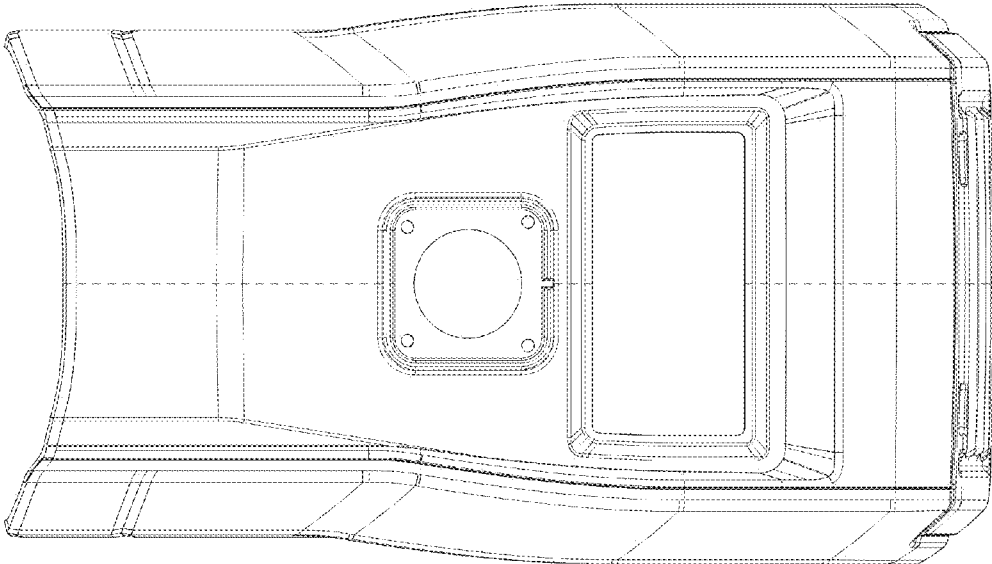

FIG. 2

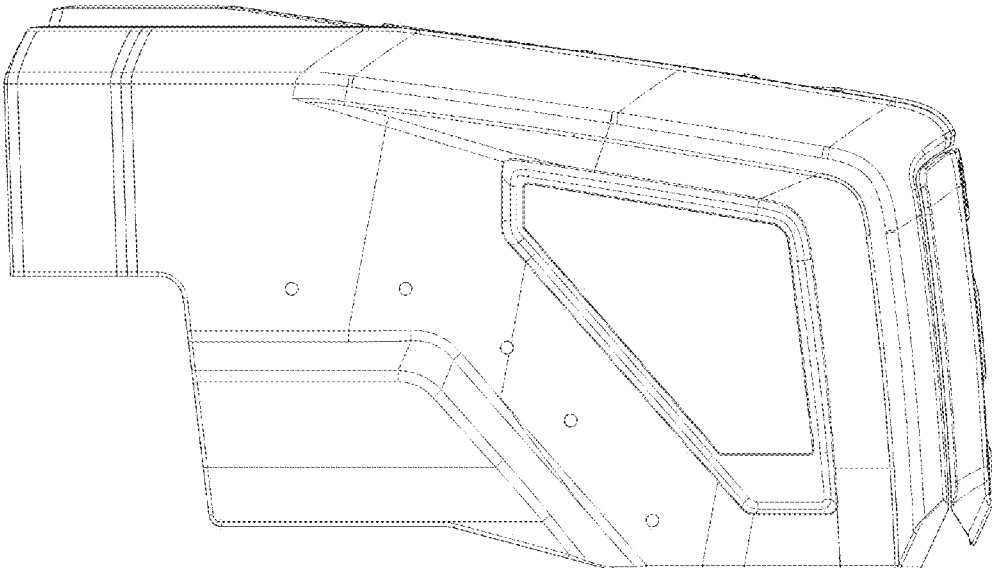

FIG. 3

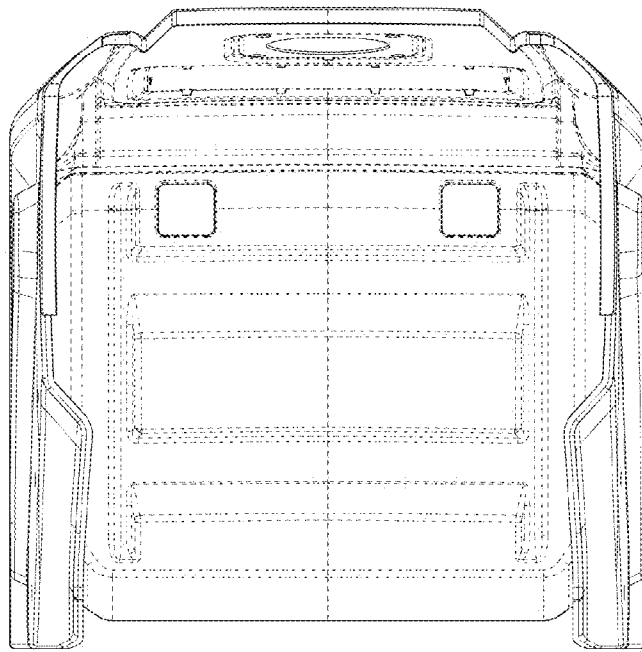

FIG. 4

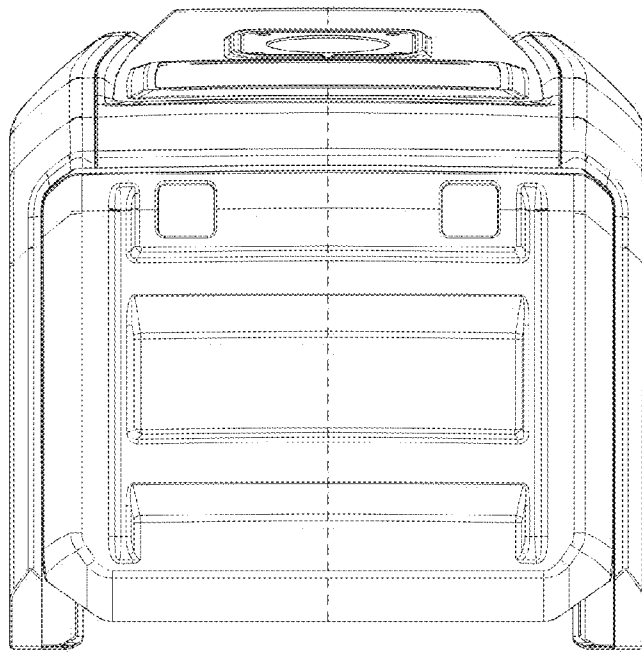

FIG. 5

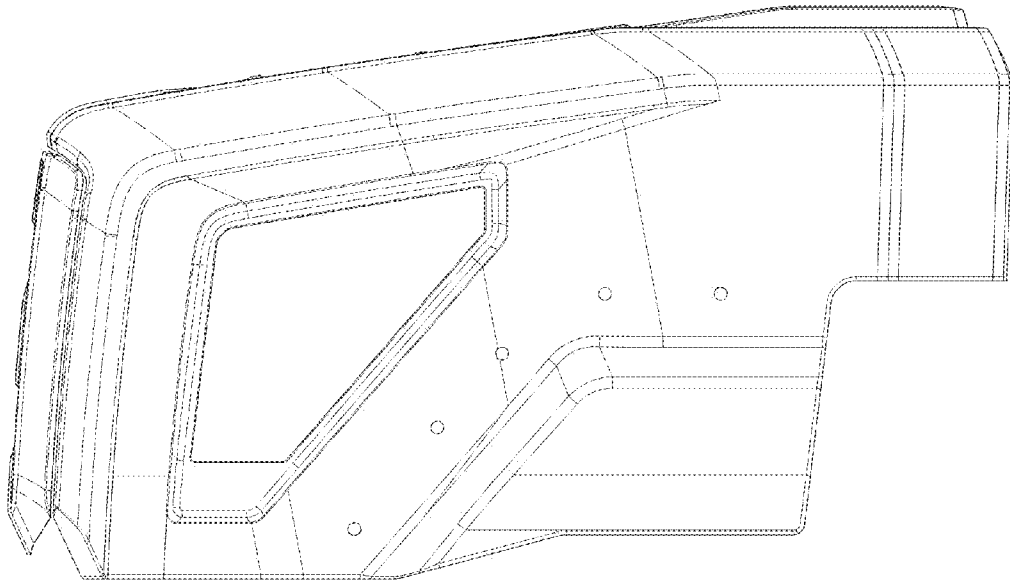

FIG. 6

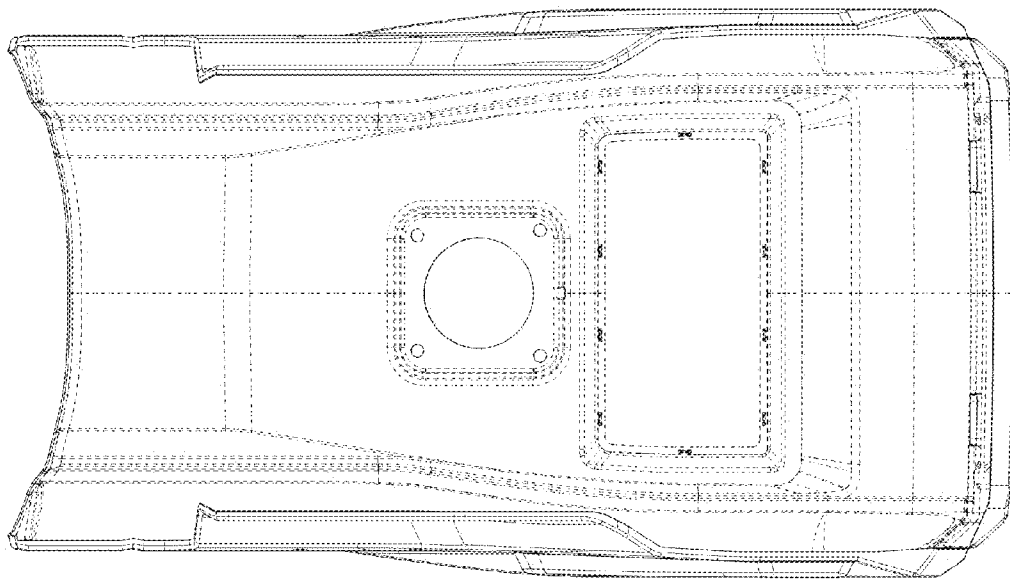

FIG. 7

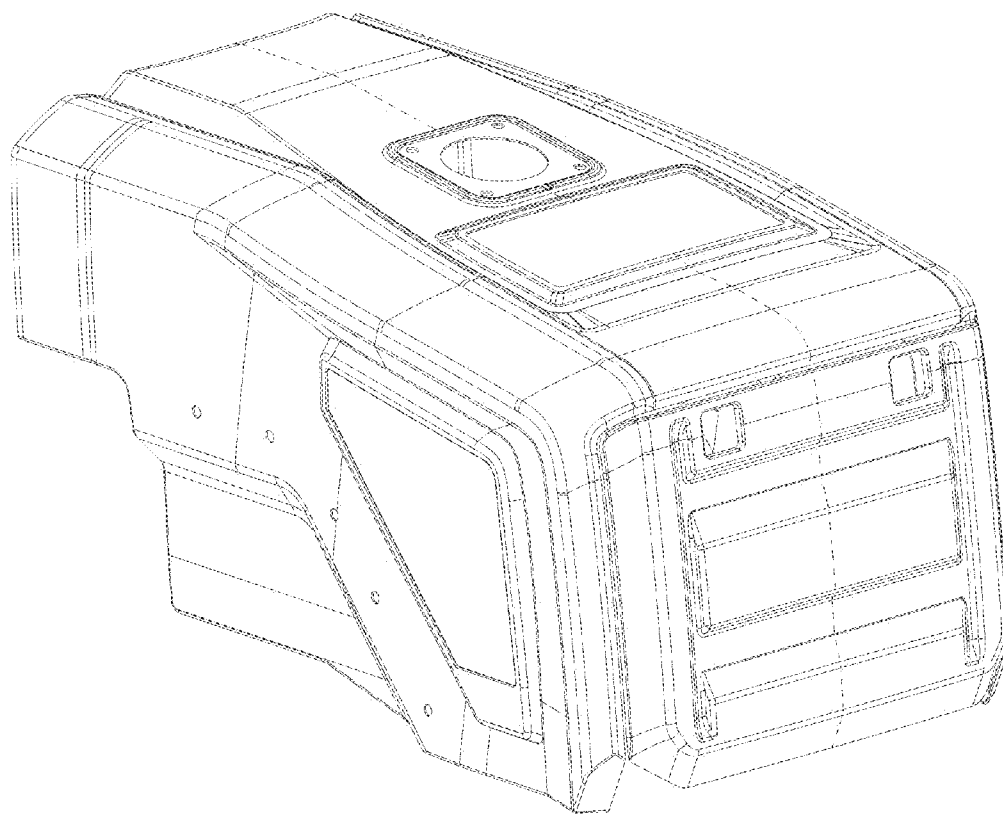

FIG. 8

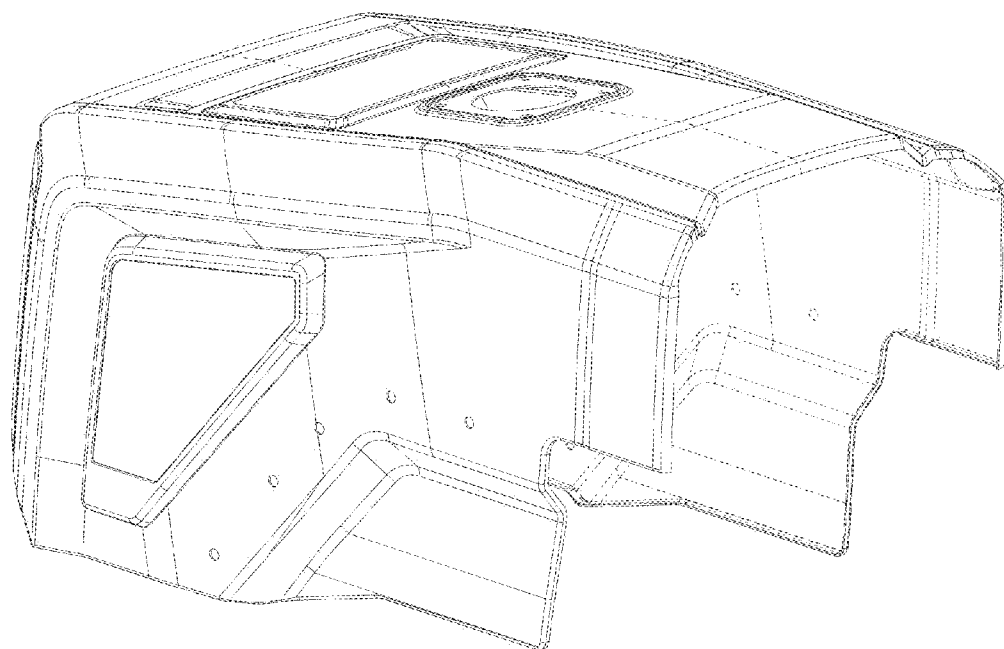

FIG. 9

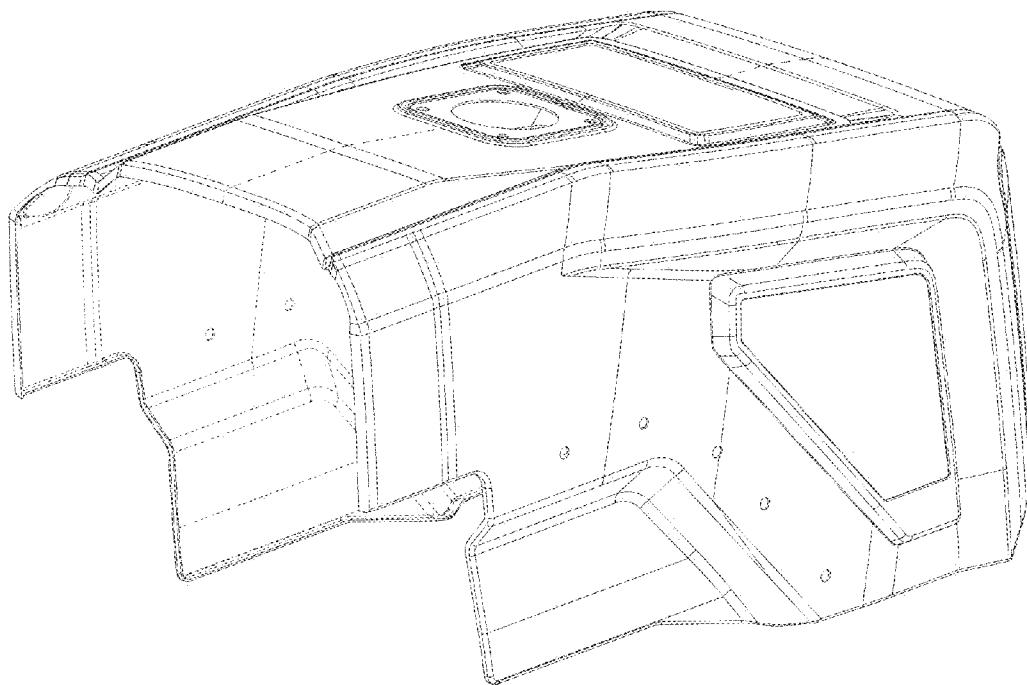

FIG. 10