



US 20140147742A1

(19) **United States**

(12) **Patent Application Publication**
Anastas et al.

(10) **Pub. No.: US 2014/0147742 A1**

(43) **Pub. Date: May 29, 2014**

(54) **BATTERY WITH INCREASED ENERGY DENSITY AND METHOD OF MANUFACTURING THE SAME**

Publication Classification

(71) Applicant: **Apple Inc.**, Cupertino, CA (US)

(51) **Int. Cl.**
H01M 4/04 (2006.01)
H01M 4/76 (2006.01)
(52) **U.S. Cl.**
CPC *H01M 4/0404* (2013.01); *H01M 4/76* (2013.01)
USPC **429/211**; 427/58

(72) Inventors: **George V. Anastas**, San Carlos, CA (US); **Gregory A. Springer**, Los Altos, CA (US); **Jack B. Rector, III**, San Ramon, CA (US); **Joshua R. Funamura**, San Jose, CA (US); **Kenneth M. Silz**, Brentwood, CA (US)

(57) **ABSTRACT**

A battery core includes an anode electrode collector and a cathode current collector. The battery core is created by defining an anode solution cavity on an anode electrode collector; defining a cathode solution cavity on a cathode electrode collector; depositing an anode solution into the anode solution cavity; depositing a cathode solution into the cathode solution cavity; curing the anode solution within the anode solution cavity; and curing the cathode solution within the cathode solution cavity. The anode electrode collector and the cathode current collector may be combined in a sandwich configuration and may be separated by one or more separators.

(73) Assignee: **Apple Inc.**, Cupertino, CA (US)

(21) Appl. No.: **14/041,773**

(22) Filed: **Sep. 30, 2013**

Related U.S. Application Data

(60) Provisional application No. 61/730,263, filed on Nov. 27, 2012.

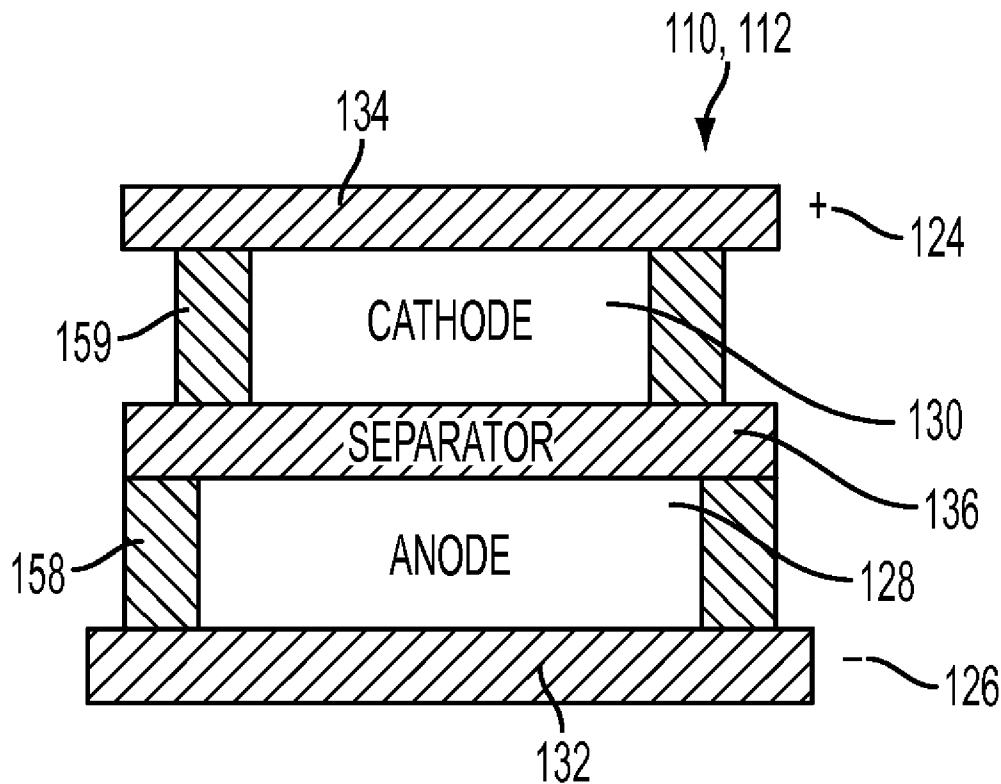

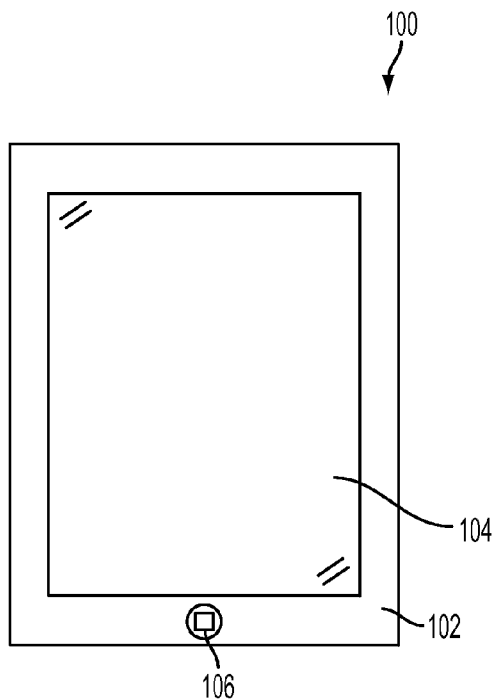

FIG. 1

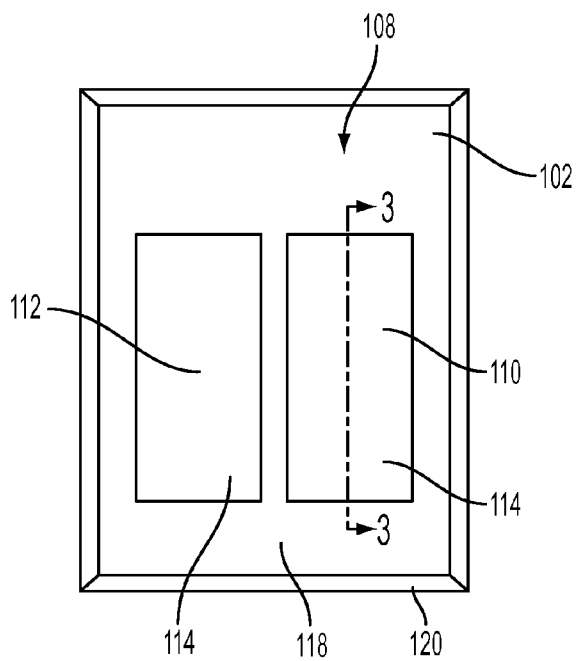

FIG. 2

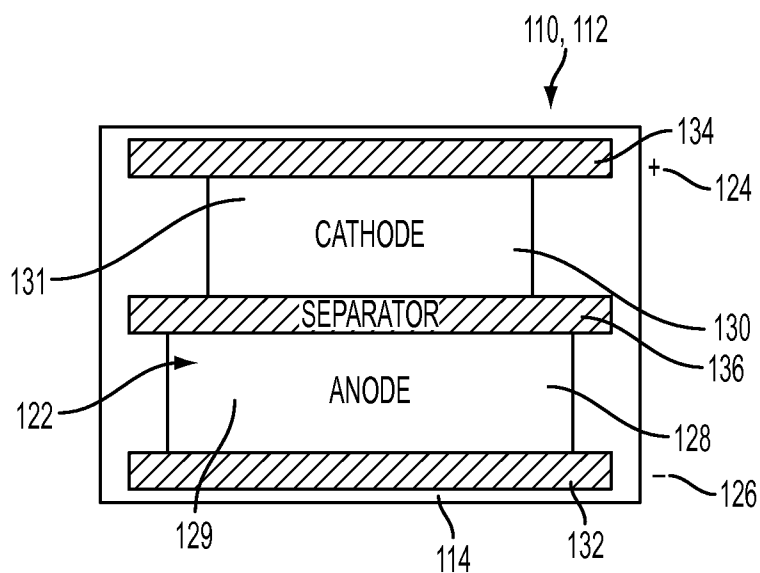

FIG. 3A

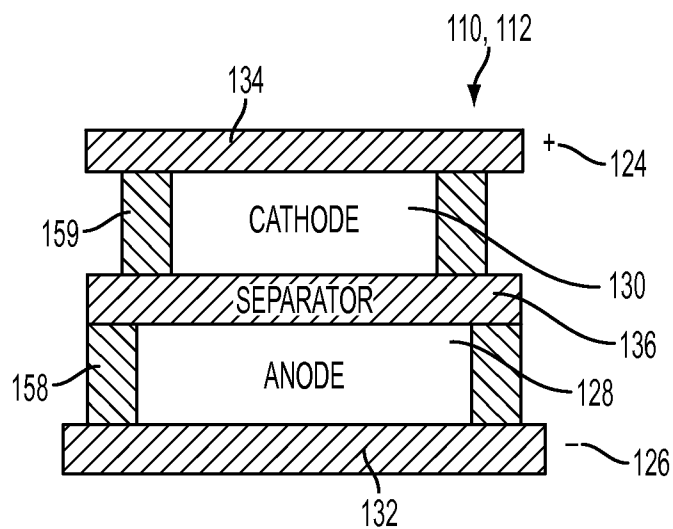

FIG. 3B

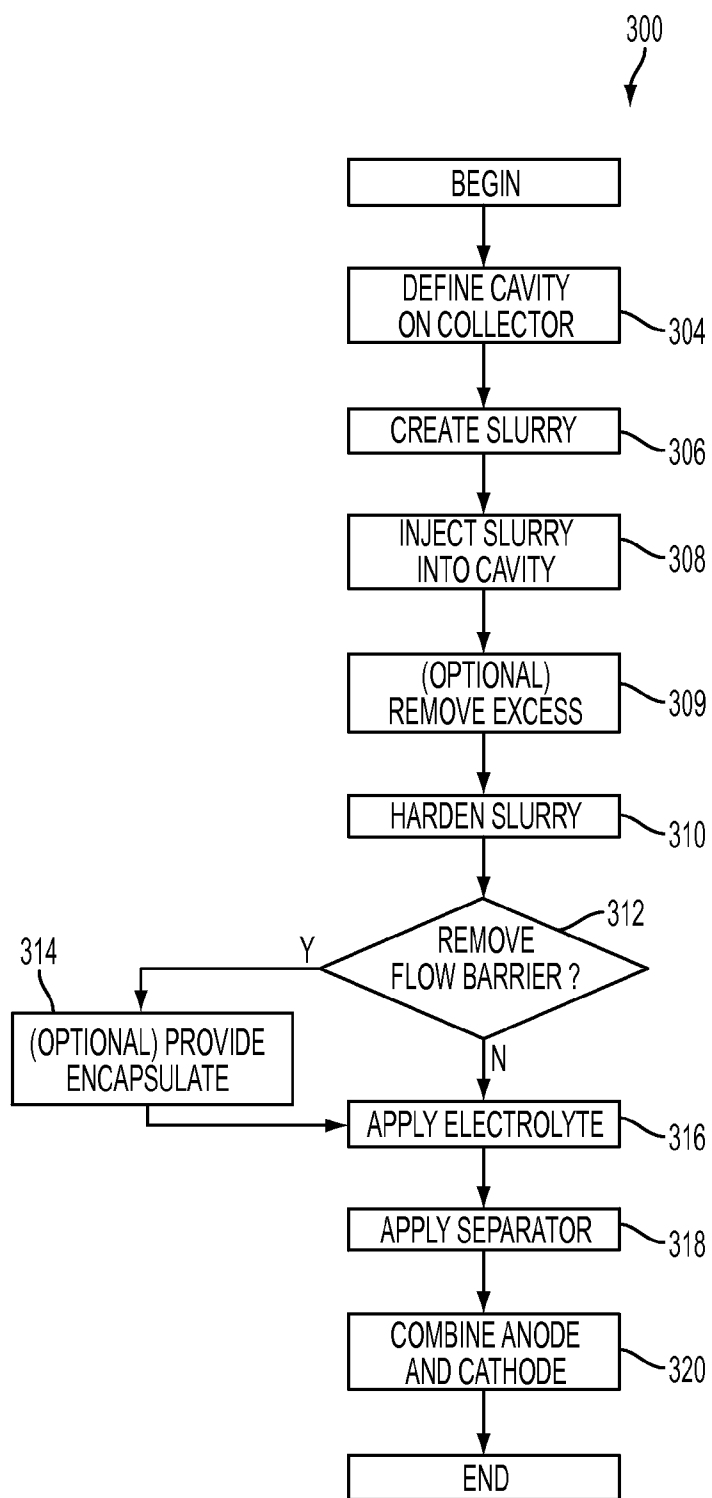

FIG. 4

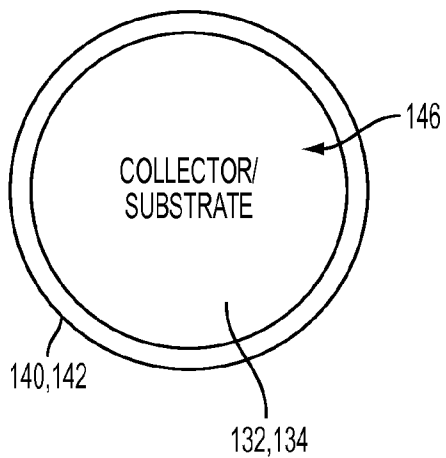

FIG. 5A

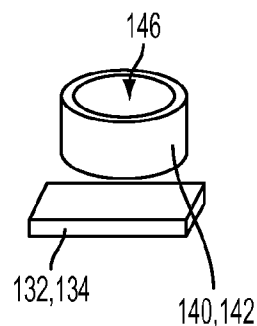

FIG. 5B

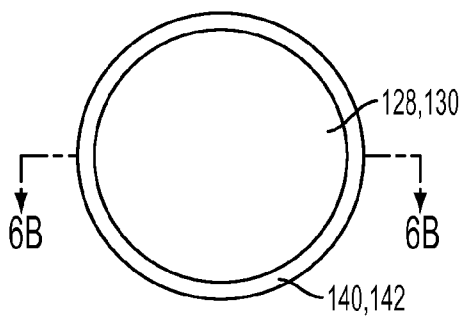

FIG. 6A

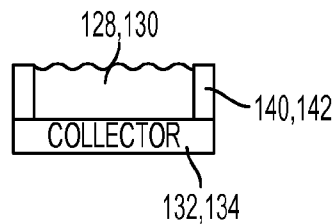

FIG. 6B

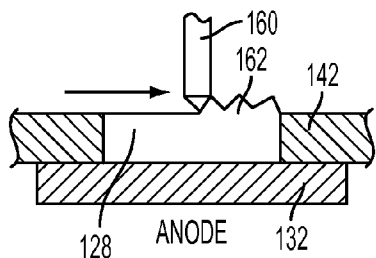

FIG. 7A

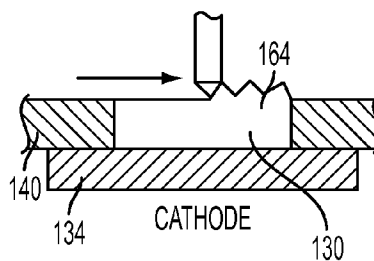

FIG. 7B

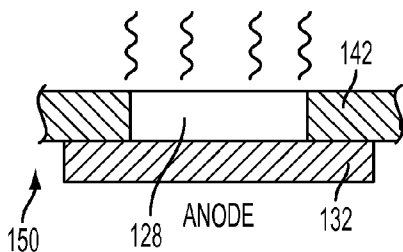

FIG. 8A

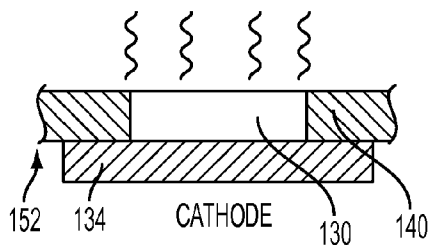

FIG. 8B

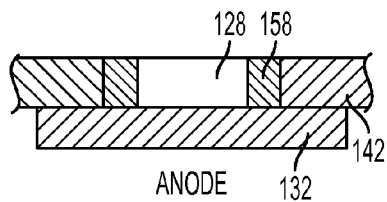

FIG. 9A

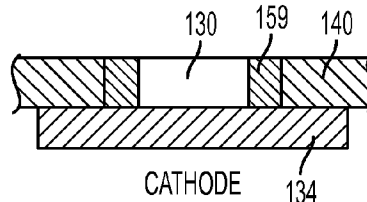

FIG. 9B

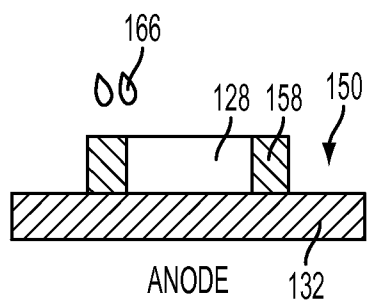

FIG. 10A

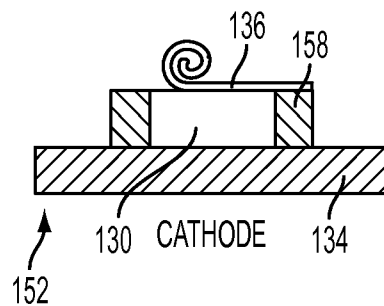

FIG. 10B

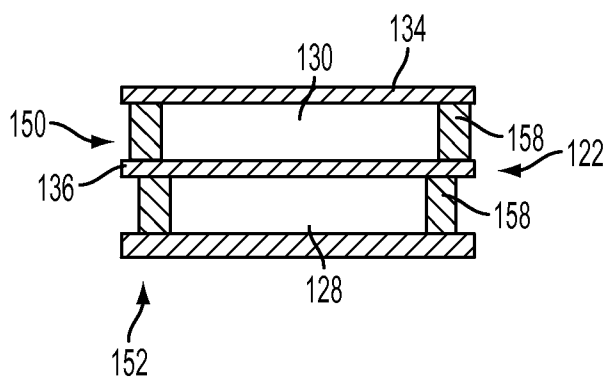

FIG. 11

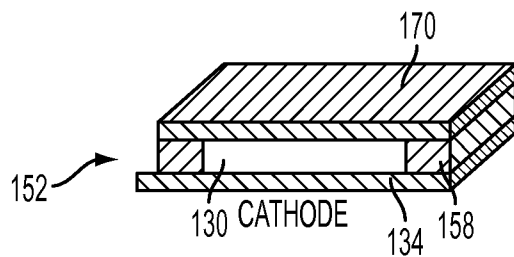

FIG. 12A

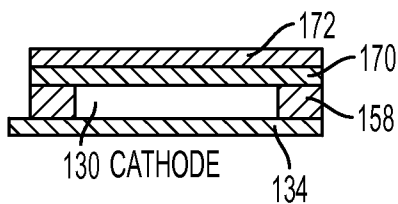

FIG. 12B

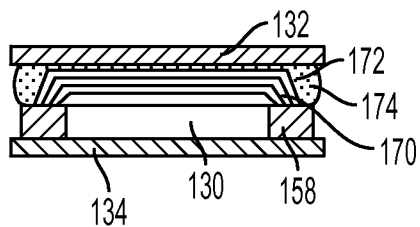

FIG. 12C

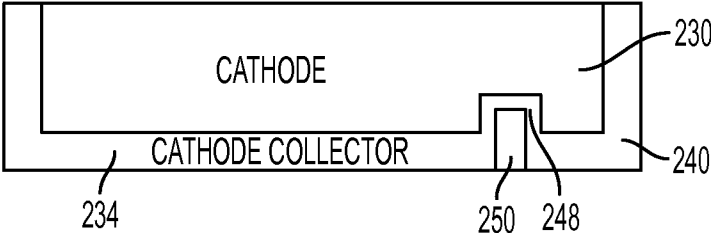

FIG. 13

BATTERY WITH INCREASED ENERGY DENSITY AND METHOD OF MANUFACTURING THE SAME

CROSS-REFERENCE TO RELATED APPLICATION

[0001] This application claims the benefit under 35 U.S.C. §119(e) of U.S. Provisional Patent Application No. 61/730,263, filed Nov. 27, 2012, entitled “Battery with Increased Energy Density and Method of Manufacturing the Same,” the entirety of which is incorporated by reference as if fully recited herein.

TECHNICAL FIELD

[0002] The present invention relates generally to batteries, and more specifically, to rechargeable batteries and methods of manufacturing rechargeable batteries.

BACKGROUND

[0003] Many components, especially electronic devices such as laptops, tablet computers, smart phones, and the like, use rechargeable batteries to provide power to one or more electronic components. A number of electronic devices may use lithium ion batteries as the power source as lithium ion batteries generally have an increased energy density (watts/liter) as compared to other types of batteries. However, as electronic components are become smaller, the current structure of the lithium ion batteries may limit the energy density that may be available for a particular size. For example, some lithium ion batteries are constructed in a “jelly roll” configuration where the anode and cathode are placed on a substrate, which is then rolled around itself to create the jelly roll. The jelly roll may then placed within a pouch, which may be generally rectangular or square. In these configurations, portions of the internal cavity of the pouch may be wasted space, as the curved jelly roll may not fit tightly within the pouch. Thus, current lithium batteries may not have the maximum energy density for a particular size, as some of the space within the pouch may go unused.

[0004] As electronic components decrease in size, and subsequently the lithium ion batteries also decrease in size, the unused space defined within the pouches may represent a higher percentage of the total size of the lithium ion battery space.

SUMMARY

[0005] In some embodiments herein, a battery and a method for manufacturing the battery are disclosed. The battery may include stacked layers that may form the components of the battery (e.g., anode, cathode). In some embodiments, the stacked configuration may not have to be “rolled” together. Accordingly, the battery configuration may have little or no unused space when positioned within a cell or pouch, which may allow the battery to have an increased energy density for a similarly sized conventional jelly roll lithium ion battery.

BRIEF DESCRIPTION OF THE DRAWINGS

[0006] FIG. 1 is a front plan view of an illustrative electronic device incorporating a battery of the present disclosure.

[0007] FIG. 2 is a front plan view of the electronic device with a top portion of the enclosure removed to illustrate the batteries within the enclosure cavity.

[0008] FIG. 3A is a cross-section view of one of the batteries illustrated in FIG. 2 taken along line 3-3 in FIG. 2.

[0009] FIG. 3B is a cross-section view of one of the batteries including a protective or encapsulant around an anode and a cathode.

[0010] FIG. 4 is a flow chart illustrating a method for manufacturing the batteries of FIG. 2.

[0011] FIG. 5A is a top plan view of one of the electrode collectors operably connected to one of the flow barriers.

[0012] FIG. 5B is a simplified exploded view of the collector and the flow barrier.

[0013] FIG. 6A is a top plan view of the electrode collector and the flow barrier with the anode or cathode solution received into the solution cavity.

[0014] FIG. 6B is a cross-section view of the electrode collector and the flow barrier taken along line 6B-6B in FIG. 6A.

[0015] FIG. 7A is a schematic view of excess anode solution being scraped from the top of the solution cavity.

[0016] FIG. 7B is a schematic view of excess cathode solution being scraped from the top of the solution cavity.

[0017] FIG. 8A is a schematic view of the anode solution being hardened within the solution cavity by being heated.

[0018] FIG. 8B is a schematic view of the cathode solution being hardened within the solution cavity by being heated.

[0019] FIG. 9A is a schematic view of the anode encapsulant being formed around the anode solution.

[0020] FIG. 9B is a schematic view of the cathode encapsulant being formed around the cathode solution.

[0021] FIG. 10A is a schematic view of an electrolyte being added to the anode prior to the anode being operably connected to the cathode.

[0022] FIG. 10B is a schematic view of a separator being operably connected to the cathode prior to the cathode being operably connected to the anode.

[0023] FIG. 11 is a schematic view of the assembled battery core including an anode and a cathode having an increased thickness.

[0024] FIG. 12A is a schematic view of an alternative manufacturing operation including adding an electrolyte layer.

[0025] FIG. 12B is a schematic view of a lithium metal layer being applied on a top of the electrolyte layer from FIG. 12A.

[0026] FIG. 12C is a schematic view of an alternative embodiment of the battery core including the lithium metal layer formed on top of the electrolyte layer.

[0027] FIG. 13 is a simplified cross-section view of a cathode layer including an electrode collector molded to conform to a surface.

DETAILED DESCRIPTION

[0028] The anode layer and a cathode layer of the battery may each have an increased thickness as compared to the anode and cathode layers for conventional lithium ion batteries. The increased thickness may provide an increase in efficiency of the battery with respect to the electrode potential of the cathode. This is because generally the electrode potential for the battery may related to the volume of the cathode as compared to the total volume of the cell. For example, energy density is generally watts per liter, and the volume of the

cathode may be a proxy for watts, such that as the cathode fills more of the total cell volume (e.g., liters), the more watts may be produced by the cell. Additionally, the increased thickness may provide an increase in energy density as more of the volume of the battery cell may be dedicated to energy providing components, e.g., the anode and cathode.

[0029] In conventional lithium ion batteries, the thickness of the cathode and/or anode may be limited due to liquid or partially liquid form of the cathode and/or anode solutions when they are applied to the substrate or electrode collectors. For example, in many instances the cathode and anode solutions or mixtures may be applied to a substrate (e.g., electrode collector) in a “slurry” or partially liquid form. This liquid form may restrict the thickness of the application of the material on the substrate as prior to curing the slurry may roll or slide off of the substrate as the thickness is increased.

[0030] In some embodiments of the present disclosure, flow barriers and/or encapsulation walls may be used during manufacturing to provide a barrier to prevent the cathode and anode solutions from rolling off of the substrate. This manufacturing method may allow the cathode and anode solutions to be applied in thicker layers, which as mentioned above, may increase the energy density of the battery cell. For example, the flow barriers may include one or more walls extending above the substrate or may include one or more wells formed into the substrate and act to retain the anode or cathode slurries (e.g., LiCo slurry) within a solution cavity or well.

[0031] In some embodiments, the flow barriers may be defined by a mask on the substrate of either the cathode or anode. In other embodiments, the flow barriers may be defined by a ring-shaped wall or otherwise defined so as to provide a well or void space on top of the cathode base that can receive the anode and/or cathode solution slurries. The wall or barrier may be removable after the slurry has hardened or may remain in position when the battery is assembled. The wall or barrier may be formed of a variety of materials which may be selected based on whether the wall or barrier may be removed. For example, in embodiments where the wall or barrier may be removable, the material selected may be easily etched or peeled away, but strong enough to retain the slurry on top of the substrate.

[0032] Once the flow barrier walls have been created, the anode and cathode mixtures may be poured or injected into a solution cavity or well defined by the flow barriers. Once the anode and cathode solutions are received into the solution cavity or well, the solutions may be baked or otherwise cured, with the flow barriers substantially preventing the slurries from escaping the solution cavity during baking. In other words, the flow barriers may substantially prevent the anode and cathode slurries from flowing off of the edge of a substrate or electrode collector. After the solutions have hardened, one or more protective walls or encapsulates may be formed around the anode and cathode. With the encapsulates in position, the anode and cathode may be combined in a sandwich configuration, with a separator positioned therebetween.

[0033] In other embodiments, the electrode collector or substrate may have a shape selected to generally match a surface where the battery may be inserted, e.g., a bottom surface of an enclosure for an electronic device. In these embodiments, the anode and/or cathode slurry may be injected into the cavity defined by the cured substrate. In these embodiments, the barrier or wall may be formed by the sub-

strate as the substrate is molded. However, in other embodiments, the substrate may be molded to correspond to a surface of the enclosure of the device and a separate wall or barrier may be operably connected thereto (e.g., two shot injection molding process where a first injection shot forms a substrate and a second injection shot forms the barrier wall), which may then be used to contain the slurry.

[0034] Turning now to the figures, an illustrative electronic device incorporating the battery will be discussed in further detail. FIG. 1 is a front plan view of an electronic device **100** incorporating one or more batteries. FIG. 2 is a front plan view of the electronic device **100** with a top enclosure and/or display removed. The electronic device **100** may include an enclosure **102**, a screen **104**, and/or one or more input/output buttons **106**. The electronic device **100** may be substantially any type of electronic device, such as, but not limited to, a tablet computer, a laptop computer, a smart phone, a gaming device, or the like. The electronic device **100** may also include one or more internal components (not shown) typical of a computing or electronic device, such as, but not limited to, one or more processors, memory components, network interfaces, and so on.

[0035] The display **104** may be operably connected to the electronic device **100** or may be communicatively coupled thereto. The display **104** may provide a visual output for the electronic device **100** and/or may function to receive user inputs to the electronic device **100**. For example, the display **104** may be a multi-touch capacitive sensing screen that may detect one or more user inputs.

[0036] As shown in FIG. 1, the enclosure **102** may form an outer surface and protective case for the internal components of the electronic device **100** and may at least partially surround the display **104**. The enclosure **102** may be formed of one or more components operably connected together, such as a front piece and a back piece, or may be formed of a single piece operably connected to the display **104**. With reference to FIG. 2, in some embodiments, the enclosure **102** may have a bottom surface **118** surrounded by an exterior wall **120** defining an enclosure cavity **108**. The enclosure cavity **108** may be enclosed by a front portion of the enclosure (not shown) and/or the display **104**. In these embodiments, the enclosure cavity **118** may be substantially sealed from the outer environment and provide a housing for one or more components of the electronic device **100**.

[0037] In some embodiments, one or more battery cells **110**, **112** may be received within the enclosure cavity **108** and operably connected to the enclosure **102**. Although two battery cells **110**, **112** are shown in some embodiments, the electronic device **100** may include only one battery cell **110**, **112** or may include three or more battery cells. Additionally, each battery cell **110**, **112** may be substantially the same or the battery cells may be different from each other (e.g., different sizes, energy densities, or types). It should be noted that although the battery cells **110**, **112** are illustrated in FIG. 2 as being generally rectangular, many other dimensions and shapes are envisioned, such as but not limited to, geometric, non-geometric, or the like.

[0038] Each battery cell **110**, **112** may provide power to one or more components of the electronic device **100**. FIG. 3A is a simplified cross-section view of one of the battery cells **110**, **112** taken along line 3-3 in FIG. 2. It should be noted the battery cells **110**, **112** may have similar internal components and so although the following discussion is made with respect to a first battery cell **110**, it is equally applicable to the second

battery cell **112**. Each battery cell **110**, **112** may include a housing **114** or pouch and a battery core **122**. The housing **114** may generally enclose the battery core **122** and provide some protection and structure for the battery core **122**.

[0039] A positive terminal **124** and a negative terminal **126** may extend through the housing **114** or otherwise be in communication with the battery core **122** while also being configured to be in communication with one or more external components (e.g., components of the electronic device **100**). The terminals **124**, **126** may transfer current from the battery core **122** to one or more components of the electronic device **100**, as well as may transfer current to the core **122** from an external power source (such as when the battery cells **110**, **112** are being charged).

[0040] A cathode electrode collector **134** may be in communication with the positive terminal **124**. The cathode electrode collector **134** may be an electrically conductive material, such as aluminum. The cathode electrode collector **134** may be a relatively thin piece of material, such as an aluminum foil. The cathode electrode collector **134** may form a substrate or base on which a cathode **130** may be positioned.

[0041] The cathode **130** or positive electrode may be a layered oxide, such as lithium cobalt oxide (LiCoO₂), a polyanion, such as lithium iron phosphate, or a spinel, such as lithium manganese oxide. As will be discussed in more detail below, the cathode **130** may include a solution **131** having an active material (e.g., LiCoO₂), a conductive additive (e.g., carbon black, acetylene black, carbon fibers, graphite, etc.), a binder (such as polyvinylidene fluoride, ethylene-propylene, and a diene), and optionally a solvent. The binder acts to hold the active material and the conductive additive together, and in instances where the binder is non-water soluble the solvent (which may be a such as N-methylpyrrolidone), acts to distribute the active material and conductive additive throughout the binder. It should be noted that the above examples of the cathode solution **131** are meant as illustrative only and many other conventional cathode materials may be used to form the cathode.

[0042] An anode electrode collector **132** may be in communication with the negative terminal **126**. The anode electrode collector **132** may be a generally conductive material, such as copper. The anode electrode collector **132** may form a base or substrate for an anode **128**. Similarly to the cathode electrode collector **134**, the anode electrode collector **132** may be a relatively thin and/or flexible piece of material, such as a copper foil.

[0043] The anode **128** or negative electrode is generally the source of ions and electrons for the battery core **122**. The anode **128** may include an anode solution **129** including an active material (e.g., lithium, graphite, hard carbon, silicon, or tin), a conductive additive (e.g., carbon black, acetylene black, or carbon fibers), a binder (such as polyvinylidene fluoride, ethylene-propylene, and a diene), and optionally a solvent.

[0044] A separator **136** may be positioned between the cathode **130** and the anode **128**. The separator may be a fiberglass cloth or flexible plastic film (e.g., nylon, polyethylene, or polypropylene). The separator **136** separates the anode **128** and cathode **130** while allowing the charged lithium ions to pass between the anode **128** and cathode **130**.

[0045] An electrolyte (not shown), which may be a mixture of organic carbonates such as ethylene carbonate or diethyl carbonate containing complexes of lithium ions. These non-aqueous electrolytes generally use non-coordinating anion

salts such as lithium hexafluorophosphate (LiPF₆), lithium hexafluoroarsenate monohydrate (LiAsF₆), lithium perchlorate (LiClO₄), lithium tetrafluoroborate (LiBF₄), and lithium triflate (LiCF₃SO₃). The electrolyte may be filled into the anode **128** and/or cathode **130** around the anode and cathode solutions **129**, **131**. In some embodiments, the electrolyte may be saturated into the separator, such that as the separator is added to the core **122**, the electrolyte may be added as well.

[0046] In some embodiments, the battery cells **110**, **112** may include one or more flow barriers and/or encapsulation walls operably connected to either or both the cathode electrode collector **134** and the anode electrode collector **132**. FIG. 3B is a simplified cross-section view of the battery cells **110**, **112** with the housing **114** hidden for clarity. With reference to FIG. 3B, an encapsulation wall **159** may be operably connected to the cathode electrode collector **134**. The cathode encapsulate **159** may span between the cathode electrode collector **134** and the separator **136**. However, in some embodiments, the cathode encapsulate **159** may terminate prior to reaching the separator **136**.

[0047] The cathode encapsulate **159** may bound either side of the cathode **130** and thus may contain the active material, the binder, and the conductive additive. In many embodiments, the encapsulate **159** may be formed during manufacturing and may replace one or more flow barriers that contain the cathode solution **131**, this is discussed in more detail below with respect to FIG. 4.

[0048] An anode encapsulate **158** may be operably connected to the anode electrode collector **132** and may extend between the anode electrode collar **132** and the separator **136**. Similarly to the cathode encapsulate **159**, the anode flow encapsulate **158** may bound either side of the anode **128** and may be substantially any material that can prevent the anode **128** material from extending over the edges of the anode electrode collector **132**. The anode encapsulate **158** may extend along the entire height or thickness of the anode **128** such that it abuts the separator **136** or may only extend along a portion of the length of the anode **128** and terminate prior to the bottom surface of the separator **136**.

[0049] A method for manufacturing the battery core **122** will now be discussed in further detail. FIG. 4 is a flow chart illustrating a method **300** for creating the battery core **122**. The method **300** may begin with operation **304** and a solution cavity may be defined on the electrode collectors **132**, **134**.

[0050] With reference to FIGS. 5A and 5B, which illustrate various views of the electrode collector and a flow barrier **140**, **142**, a flow barrier **140**, **142** may form a perimeter wall or retaining structure that may extend around an edge of the collectors **132**, **134** to define a solution cavity **146** or well between the inner surface of the flow barrier **140**, **142** and the top surface of the collectors **132**, **134**. For example, an anode flow barrier **142** and a cathode flow barrier **140** may be formed on respective electrode collectors **132**, **134** to define the solution cavity **146** for each substrate or electrode collector **132**, **134**.

[0051] In some embodiments the flow barriers **140**, **142** may be integrally formed with the electrode collectors **132**, **134**. For example, the flow barriers **140**, **142** may be formed by folding or bending certain portions (e.g., the outer edges) of the electrode collectors **132**, **134** upwards to define the solution cavity **146**. In other embodiments, the flow barriers **140**, **142** may be a separate component from the electrode collectors **132**, **134** and may be operably connected thereto or positioned thereon. For example, in some embodiments, the

flow barriers **140, 142** may be a plastic wall formed through masking deposition process, may be formed while the electrode collectors are formed (e.g., metal injection molding the electrode collectors to define one or more recesses or walls), or may otherwise be defined or connected to the electrode collectors.

[0052] In some embodiments, the flow barriers **140, 142** may extend upwards from the electrode collectors **132, 134**. However, in other barriers, the solution cavity **146** may be defined as a well, e.g., through etching or otherwise forming recesses within the electrode collectors **140, 142**. In these embodiments, the flow barriers **140, 142** may be formed integrally with the electrode collectors **132, 134**.

[0053] It should be noted that although the flow barriers **140, 142** and the electrode collectors **132, 134** are illustrated as having a generally circular shape in FIGS. 5A and 5B, the shape of the electrode collector **134** and the flow barrier **140** may be modified as desired. For example, the electrode collector and the flow barrier **140** may be rectangular, square, other geometric or non-geometric shapes, or the like

[0054] With reference again to FIG. 4, once the solution cavity **146** has been defined, the method **300** may proceed to operation **306**. In operation **306** the anode **128** and cathode **130** slurries or solutions **129, 131** may be created. As briefly discussed above, the anode and cathode solutions **129, 131** may each include an active material, a binder, and a conductive material. For the anode **128**, the active material may be lithium or graphite infused with lithium ions, the binder may be polyvinylidene fluoride, and the conductive additive may be carbon black. For the cathode **130**, the active material may be LiCoO_2 , the binder may be polyvinylidene fluoride, and the conductive additive may be carbon black. It should be noted that many other active materials, binders, and conductive additives are envisioned and the aforementioned compounds are illustrative only. Once the active material, binder, and conductive additives are combined to create the anode solution **129** and the cathode solution **131** slurries may be created.

[0055] The anode solution **129** and cathode solution **131** slurries may be a paste that may have a somewhat low viscosity, such that when placed on a surface the slurries may slide or roll over the edge of the surface. For example, when the solutions **129, 131** are initially created, the binder may not yet have hardened into a more solid structure and so the slurries may be very easily moved.

[0056] Once the solution **129, 131** slurries have been created, the method **300** may proceed to operation **308**. In operation **308** the solutions **129, 131** may be injected or deposited into their respective solution cavities **146**. That is, the anode solution **129** may be injected into the solution cavity **146** defined on the anode electrode collector **132** and the cathode solution **131** may be injected in to the solution cavity **146** defined on the cathode electrode collector **134**. The solutions **129, 131** may be injected through a variety of processes, such as, but not limited to, injection molding, deposition processes, or the like.

[0057] FIG. 6A is a top plan view of the anode and cathode solutions **129, 131** received into the solution cavity **146**. FIG. 6B is a cross section view of the anode and cathode solutions **131, 129**, respectively, received into the solution cavity **146**. Referring to FIGS. 6A and 6B, the cathode **131** solution (e.g., cathode active material, binder, and conductive particles) may be injected or poured into the solution cavity **146**. In some embodiments, the cathode solution **131** may be injected into the solution cavity **146** such as through injection mold-

ing, screen printing, masking, or other deposition techniques. Similarly, the anode solution **129** (e.g., anode active material, binder, and conductive particles) may be injected or poured into the respective solution cavity **146** defined on the anode electrode collector **132**.

[0058] The flow barriers **140, 142** may substantially prevent the liquid or pre-hardened solutions **129, 131** from rolling or flowing off of the edges of the electrode collectors **132, 134**. This is because the cathode solution **131** and/or anode solution **129** may have a somewhat low viscosity, but due to the flow barriers **140, 142** may be bound within the solution cavities. As described above with respect to operation **306**, the cathode and anode solutions **129, 131** may be a slurry, paste, or otherwise have a relatively low viscosity.

[0059] With the battery core **122**, the flow barriers **140, 142** may substantially contain the anode and cathode solutions **129, 131** within the well or solution cavity **146**. The flow barriers **140, 142** may therefore allow the amount of anode and cathode solutions **129, 131** applied to the electrode collectors **132, 134** to be increased. As will be discussed below, the increase in solution applied may increase the thickness of either or both the anode and cathode **128, 130** layers as compared to conventional batteries. This is because the flow barriers **140, 142** may prevent the slurries from sliding off of the collector.

[0060] With reference again to FIG. 4, once the anode and cathode solutions **128, 130** have been injected into or otherwise poured into the solution cavity **146**, the method **300** may proceed to optional operation **309**. In operation **309**, excess solution **129, 131** may be removed from the solution cavity **146**. In some embodiments, the anode and/or cathode solutions may be overfilled in the cavity **146**. FIGS. 7A and 7B illustrate the anode and cathode, respectively, being formed during operation **309**. With respect to FIGS. 7A and 7B, a blade **160** or other tool (e.g., rod, level, or laser) may be used to remove excess slurry **162, 164** from each the anode solution **129** and the cathode solution **131**. For example, the excess slurry **162, 164** may be scraped off the top of the solution cavity **146** as the blade **160** extends across the top surface of the retaining barriers **140, 142**.

[0061] In some embodiments, operation **309** may be used to control the thickness and/or shape of the anode and/or cathode. In other words, the blade **160** may be configured to remove a predetermined amount of solution **129, 131** which may determine the overall thickness of the anode and cathode.

[0062] With reference again to FIG. 4, after the excess slurry **162, 164** has been removed or the anode solution **129** and cathode solutions **131** have been otherwise shaped as desired, the method **300** may proceed to operation **310**. In operation **310** the anode solution **129** and the cathode solution **131** may be cured or otherwise hardened. With respect to FIGS. 8A and 8B, in some embodiments, the anode layer **150** (including the anode solution, the anode electrode collector, and the flow barrier) and the cathode layer **152** (including the cathode solution, the cathode electrode collector, and the flow barrier) may be heated to harden the anode and cathode solutions **129, 131**. For example, the anode **128** and cathode **130** (along with the respective electrode collectors) may be heated or baked to allow the binder to cure. However, the type of hardening process may depend on the type of solution used, and thus may vary as required.

[0063] In some embodiments, a nickel iron alloy such as INVAR or KOVAR may be utilized for operation **310**. Alter-

natively, other materials having a low or particularly selected (matched) coefficient of thermal expansion (CTE), in order to maintain particular dimensions with respect to the anode and cathode solutions 129, 131 during a heating and any subsequent cooling process used to cure or hardened the anode solution 129 and/or cathode solution 131.

[0064] Returning again to FIG. 4, once the anode solution 129 and the cathode solution 131 have hardened, the method 300 may proceed to operation 312. In operation 312 it may be determined whether the flow barriers 140, 142 should be removed. In some embodiments the flow barriers 140, 142 may be removed after the cathode or anode solution has hardened. This is because once hardened the cathode or anode solution may not roll off of the electrode collector. However, in other embodiment's the material of the flow barriers 140, 142 may be selected so as to not interfere with the chemical reactions within the battery core 122 and may remain in place during use.

[0065] In instances where the flow barriers 140, 142 may be plastic or other material portions operably connected to a top surface of the electrode collectors 132, 134 (such as an O-ring or donut shape), the flow barriers 140, 142 may be removed from the sides of the anode 128 and/or cathode 130. For example, the flow barriers 140, 142 may be etched away, dissolved through a chemical reaction, or peeled or pulled away from the anode solution 129 and/or cathode solution 131. However, in some instances, the flow barriers 140, 142 may be defined by edges of the electrode collectors 132, 134 and may not be removed or may be formed of an inert material and may not generally affect the performance of the battery core 122 and thus may not be removed.

[0066] If the flow barriers 140, 142 are removed, the method 300 may proceed to operation 314. In operation 314, encapsulation walls 158, 159 may be applied to the edges of the anode 128 and cathode 130. FIGS. 9A and 9B illustrate the anode and cathode as the encapsulation walls 158, 159 are added. Operation 312 may include removing the flow barrier mask (e.g., flow barrier walls) and positioning a secondary or encapsulation mask with respect to the anode or cathode layers and the collector substrate. The encapsulant 158, 159 may be a thermoplastic or other polymer deposited about the anode and cathode solutions 128, 130 based on the encapsulation mask geometry.

[0067] The encapsulant 158, 159 may form a structure barrier for the two solutions 129, 131. The encapsulant 158, 159 may function as a structural retaining wall to help maintain the structure of the hardened solutions 128, 130 with the flow barriers 140, 142 removed. The encapsulant 158, 159 may also help to protect the anode and cathode. With reference to FIGS. 9A and 9B, the encapsulation 158, 159 may be deposited onto the edges of the anode and cathode solutions 129, 131 after the flow barriers 140, 142 have been removed. Alternatively, holes may be defined in the flow barriers 140, 142 which may receive the material forming the encapsulation walls 158, 159. Once the encapsulant 158 has been deposited it may need to be cured, in which case the method 300 may further including a curing time. The encapsulant 158, 159 may be cured by heating, ultraviolet radiation, or chemical means. Alternatively, a self-curing encapsulant compound may be utilized, for example an epoxy resin.

[0068] It should be noted that in some embodiments, the encapsulant 158, 159 may be provided whether the flow barriers 140, 142 are removed or not removed. Accordingly,

operation 314 may be included within the process flow of the method 300 regardless of whether the flow barrier walls are removed.

[0069] With reference again to FIG. 4, if the flow barriers 140, 142 are not removed, or after operation 314, the method 300 may proceed to operation 316. With reference to FIG. 10A, in operation 316, an electrolyte 166 may be applied. During operation 314 the method 300 may also proceed to operation 318 and the separator 136 may be added. For example, the separator 136 material may be permeable and applied to either or both the anode 128 or cathode 130 layers and the separator 136 may be saturated or permeated with the electrolyte 166 material. Alternatively, operations 316, 318 may be separate, and the electrolyte 166 may be applied as a liquid first to either the anode or cathode, and then the separator 136 may be applied. It should be noted that in operation 318, in some embodiments, additional encapsulant 158, 159 may be applied along with the separator 136 to the anode and/or cathode.

[0070] With reference to FIG. 10B, in embodiments where the separator 136 may be a thin film, the separator 136 may be rolled onto either the anode layer 150 or the cathode layer 152. However, in other embodiments the separator 136 may be positioned on top of, deposited, or otherwise connected to one of the layers 150, 152. In some embodiments, the separators 136 may be applied to a top surface of the cathode layer 152 and may be cover a top surface of the encapsulate 158 and the cathode solution 130.

[0071] Referring again to FIG. 4, once the separator 136 is in place, method 300 may proceed to operation 320. In operation 320 the anode layer 150 and cathode layer 152 may be combined together. FIG. 11 illustrates a schematic view of the battery core 122 with the two layers 150, 152 combined. With reference to FIG. 11, the cathode layer 150 may be positioned on top of the anode layer 152 with the separator 136 positioned between. Due to the flow barrier walls 140, 142, the anode 128 and the cathode 130 may have an increased thickness as compared to conventional lithium ion batteries. For example, the cathode 130 may have a thickness ranging between 10 to 25 microns. This increased thickness may provide for an increased energy density as more electrons may be stored in the anode and cathode as compared to thinner anode and cathode layers.

[0072] Additionally, because the anode 128 and cathode 130 layers may be constructed thicker, the battery core 122 may not need to be wound around itself to provide sufficient energy density for providing power to the electronic device 100. This may allow for the thickness of the anode electrode collector 132 and/or the cathode electrode collector 134 to increase in thickness. By increasing the thickness the collectors 132, 134 may be formed molded to conform to certain shapes and may help to form the flow barriers for the solutions, this will be discussed in more detail below with respect to FIG. 13.

[0073] Returning again to FIG. 4, after the anode 128 and cathode 130 have been sandwiched together, the method 300 may proceed to the end state 322 and may terminate.

[0074] In some embodiments, the cathode layer 152 as formed in FIG. 9B may be operably connected with a metal anode deposition rather than the anode solution illustrated in FIGS. 9A-11. With reference to FIGS. 12A-12C, after the cathode layer 152 has been formed as illustrated in FIG. 9B, an electrolyte layer such as lithium phosphorous oxynitride (LiPO_xN_y) may be applied to a top surface of the cathode 130

and encapsulant **158, 159**. For example, once the electrolyte layer is deposited, a lithium (Li) metal layer **172** may be deposited on top of the electrolyte layer **170**. FIG. **12B** illustrates the Li metal layer **172** being formed on top of the electrolyte layer **170**. The Li metal layer **172** may be applied as a powder deposition or a physical vapor deposition (PVD). With reference to FIG. **12C** once the Li metal layer **172** is formed, the anode electrode collector **132** may be operably connected on top of the Li metal layer **172** with a flexible sealant **172** connecting the anode electrode collector **132** to the encapsulate **158**.

[0075] As briefly highlighted above, because the battery core **122** may be stacked rather than rolled, due to the increased thickness of the anode and cathode layers, the electrode collectors **132, 134** or substrates may be increased in thickness. Conventional lithium ion batteries typically include electrode collectors that are a thin, flexible material (e.g., aluminum foil) so that the collectors can be wrapped around themselves when the jelly roll (e.g., rolled package of the substrate, anode, and cathode) is formed. The flexibility required for the jelly roll configuration may limit the thickness and/or materials that may be used for the battery core. However, with the battery core **122** manufactured with the method **300**, the increased anode **128** and cathode **130** thickness may allow for the core **122** to be stacked rather than rolled. The stacking may allow the electrode collectors **132, 134** to be thicker and/or formed of non-flexible materials, which may allow the collectors to be molded or otherwise formed as desired. FIG. **13** is simplified cross-section view of an electrode collector **234** including a surface corresponding feature. In some embodiments, either or both of the electrode collectors **132, 134** may be molded or otherwise formed to define a particular shape. For example, the electrode collectors **132, 134** may be molded to generally correspond to the bottom surface **118** of the enclosure. For example, the electrode collector **234** may be metal injection molded (MIM), machined, or otherwise formed to correspond to a desired shape.

[0076] In these embodiments, the electrode collectors **132, 134** may have an increased energy density efficiency, as the solution cavity **146** for holding the anode or cathode solutions may trace along the topography of the enclosure which may provide for the maximum amount of internal space for the solutions.

[0077] With reference to FIG. **13**, the electrode collector **234** may include a surface corresponding feature **248** which may be a raised protrusion defining a protraction slot **250**. In this embodiment, the protrusion slot **250** may be configured to receive a protrusion, such as a ridge or discontinuity on the bottom surface **118** (or other surface) of the enclosure **102**. Rather than reducing the entire height of the electrode collector **234** and thus the amount of solution it can contain, the electrode collector **234** may include the surface corresponding feature **248** that may be raised into the solution cavity. Accordingly, although the height of the solution cavity may be reduced at the surface corresponding feature **248** (to accommodate the protrusion), the entire volume of the solution cavity may not have to be substantially reduced to accommodate the protrusion.

[0078] The electrode collector **234** may be used to form either the anode electrode collector and/or the cathode electrode collector. Additionally, the electrode collector **234** may be shaped to correspond to a number of different surfaces, dimensions, and/or shapes. For example, the electrode col-

lector **234** may be configured to match an internal surface of the battery housing **114** versus the enclosure. Moreover, although the electrode collector **234** has been discussed as being injection molded, other forming techniques may be used.

[0079] The foregoing description has broad application. For example, while examples disclosed herein may focus on batteries for electronic devices, it should be appreciated that the concepts disclosed herein may equally apply to substantially any other type device using a portable or rechargeable power supply. Similarly, although the methods are discussed with respect to certain manufacturing techniques, the battery structures may be manufactured in other methods or techniques. Accordingly, the discussion of any embodiment is meant only to be exemplary and is not intended to suggest that the scope of the disclosure, including the claims, is limited to these examples.

We claim:

1. A method for creating a battery core, comprising:
 - defining an anode solution cavity on an anode electrode collector;
 - defining a cathode solution cavity on a cathode electrode collector;
 - depositing an anode solution into the anode solution cavity;
 - depositing a cathode solution into the cathode solution cavity;
 - curing the anode solution within the anode solution cavity; and
 - curing the cathode solution within the cathode solution cavity.
2. The method of claim 1, wherein the anode solution cavity is defined by at least one flow barrier wall operably connected to the anode electrode collector.
3. The method of claim 2, further comprising removing the at least one flow barrier wall after curing the anode solution.
4. The method of claim 2, wherein the cathode solution cavity is defined by at least one additional flow barrier wall operably connected to the cathode electrode collector.
5. The method of claim 2, wherein the at least one flow barrier wall is formed during an injection molding or masking process.
6. The method of claim 2, wherein the at least one flow barrier wall is ring-shaped.
7. The method of claim 1, further comprising encapsulating at least one of the cured anode solution or the cured cathode solution.
8. The method of claim 7, wherein said operation of encapsulating at least one of the cured anode solution or the cured cathode solution further comprises encapsulating the at least one of the cured anode solution or the cured cathode solution utilizing at least one polymer.
9. The method of claim 1, further comprising combining the anode electrode collector and the cathode electrode collector.
10. The method of claim 9, wherein said operation of combining the anode electrode collector and the cathode electrode collector further comprises inserting at least one separator between the anode electrode collector and the cathode electrode collector.
11. The method of claim 1, wherein at least one of the anode electrode collector or the cathode electrode collector have a shape that generally matches a surface of a device where a battery including the battery core is inserted.

12. The method of claim **11**, further comprising molding the at least one of the anode electrode collector or the cathode electrode collector to have the shape.

13. The method of claim **12**, wherein at least one of the anode solution cavity or the cathode solution cavity is formed during the molding.

14. The method of claim **12**, wherein at least one of the anode solution cavity or the cathode solution cavity is formed after the molding.

15. The method of claim **1**, wherein the anode solution cavity prevents the anode solution from flowing off at least one edge of the anode electrode collector.

16. The method of claim **1**, further comprising removing at least one of excess anode solution from the anode solution cavity or excess cathode solution from the cathode solution cavity.

17. The method of claim **1**, wherein at least one of said operation of curing the anode solution or curing the cathode solution comprises at least one of heating or baking.

18. The method of claim **1**, wherein the cathode solution cavity prevents the cathode solution from flowing off at least one edge of the cathode electrode collector.

19. A battery core, comprising:

an anode electrode collector including a cured anode solution in an anode solution cavity;

a cathode electrode collector, coupled to the anode electrode collector, including a cured cathode solution in a cathode solution cavity;

wherein the anode solution cavity was defined in the anode electrode collector, the cathode solution cavity was defined in the cathode electrode collector, the anode solution was deposited into the anode solution cavity and then cured, and the cathode solution was deposited into the cathode solution cavity and then cured.

20. A battery, comprising:

a battery core, comprising:

an anode electrode collector including a cured anode solution in an anode solution cavity;

a cathode electrode collector, coupled to the anode electrode collector, including a cured cathode solution in a cathode solution cavity;

wherein the anode solution cavity was defined in the anode electrode collector, the cathode solution cavity was defined in the cathode electrode collector, the anode solution was deposited into the anode solution cavity and then cured, and the cathode solution was deposited into the cathode solution cavity and then cured.

* * * * *