

W. H. SCHULTE.
FLUSH VALVE.
APPLICATION FILED JUNE 9, 1916.

1,225,278.

Patented May 8, 1917.

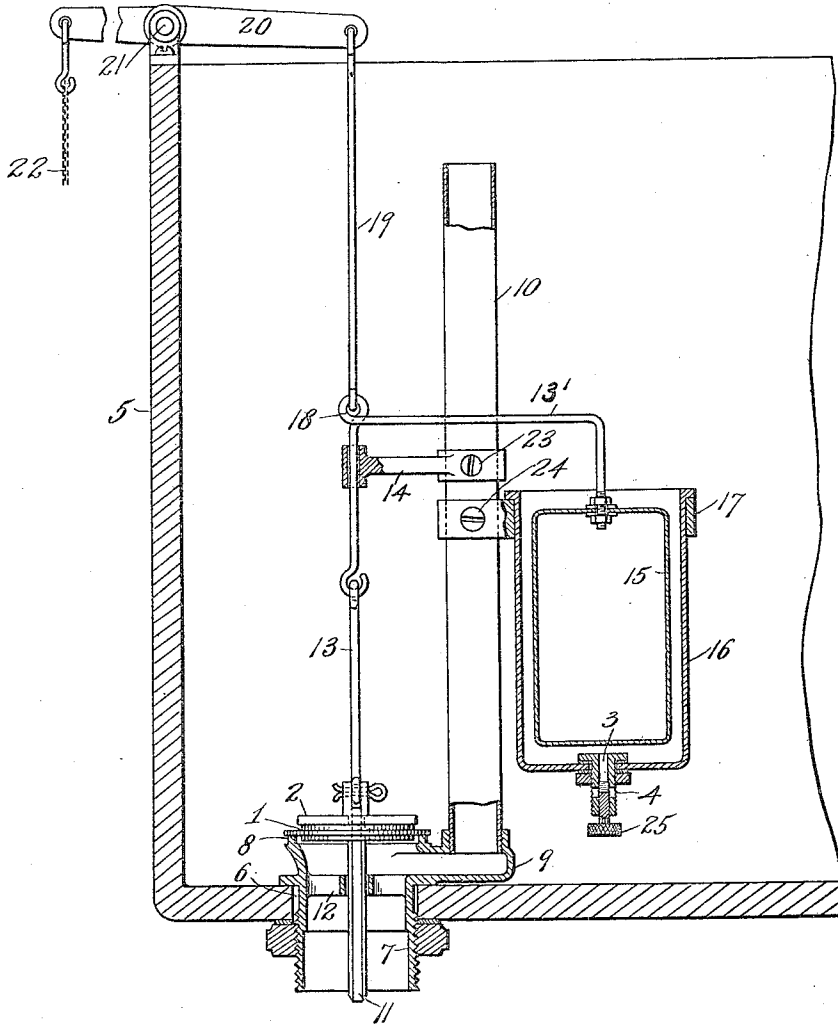

Inventor:
William H. Schulte
by his Attys:
Philip Langmuir Kennedy

UNITED STATES PATENT OFFICE.

WILLIAM H. SCHULTE, OF TRENTON, NEW JERSEY.

FLUSH-VALVE.

1,225,278.

Specification of Letters Patent.

Patented May 8, 1917.

Application filed June 9, 1916. Serial No. 102,623.

To all whom it may concern:

Be it known that I, WILLIAM H. SCHULTE, a citizen of the United States, residing at Trenton, county of Mercer, and State of New Jersey, have invented certain new and useful Improvements in Flush-Valves, fully described and represented in the following specification and the accompanying drawings, forming a part of the same.

This invention relates to improvements in flush tanks to be used in connection with water-closets, urinals, &c., and has for its object to provide a device of this character, the parts of which are few in number, simple in construction, adapted to move as a single unit, in which the after flow or refill is secured by the slow closing of the main valve, and which may easily be regulated to meet such requirements as may be imposed upon them.

In the accompanying drawing forming a part of this specification, there is shown for the purpose of illustration, a flush tank of the preferred form embodying all the features of the invention, and this flush tank will now be described in detail, and the features forming the invention then specifically pointed out in the claims.

In the drawing is shown a central vertical section through the flush tank, showing that portion of the tank containing the flush valve with the operating parts partly in section.

Referring to the drawing, 5 is the flush tank supplied with a port 6 to admit the discharge connection 7 provided with a discharge valve seat 8, and a portion 9 extending sidewise for connection with the overflow pipe 10. The discharge valve 1, weighted by weight 2, is seated on valve seat 8 and provided with a downwardly extending valve stem 11 guided by spider 12 mounted within the discharge connection 7. Connected to the top of valve 1, is a lift rod 13 running through bracket 14, shown as adjustably secured to overflow pipe 10 by set screw 23, and then at right angles by arm 13' having a downwardly bent end connected to float 15 operating within float tank 16, supported by bracket 17 adjustably secured to overflow pipe 10 by set screw 24. The float tank 16 is provided with an inlet and an outlet passage 3 provided with ports 4 controlled by the regulating screw 25, so that the rate of flow from the float tank 16 may be thus controlled. To an eye

18, formed in rod 13 above the valve, is attached a connecting rod 19, to which in turn is joined a lever 20, pivoted at 21 and provided with the usual pull-chain 22.

The operation of the construction is as follows:

When the tank 5 is full, the upward lift of the float 15 tends to raise the valve 1 against the weight 2, but owing to the pressure of the water in the tank, which is pressing the valve downward against atmospheric pressure below the valve, this tendency is not sufficient to raise the valve. When the valve 1 is raised to open the discharge, by a downward pull upon the chain 22, the pressure above and below the valve 1 is equalized sufficiently so that the float 15 holds the valve 1 open after the hand-pull has been released. The valve is held open in this manner until the water in the float tank 16 has run out through passage 3 and ports 4 sufficiently, so that the weight of the float 15 in combination with the weight 2 closes the flush valve 1, the time of the flush flow and refill of the closet bowl being determined by the adjustment of the regulating screw 25. The valve 1 being in closed position, the tank is filled again by an inlet pipe and valve of the usual kind, not shown in the drawing, and this water flows through ports 4 and passage 3 into the float tank 16 in order to refill the latter, whereupon the construction is ready for flushing.

It is understood that applicant does not limit himself to the specific construction shown in the drawing, as the float may be connected in various positions to the valve without departing from the invention as defined by the claims.

What is claimed is:

1. A flushing apparatus having a flush tank and a flush valve, a float connected to said valve which by rising tends to open the valve and acts to hold the valve open during the flushing, and a float tank for said float having the flow of water therefrom controlled to secure a slow closing of the flush valve.

2. A flushing apparatus having a flush tank and flush valve, a float connected to said valve which by rising tends to open the flush valve, a float tank and means for controlling the discharge from said float tank to regulate the length of the flow.

3. In a flushing apparatus, the combina-

- tion with a flush tank, of a flush valve, a float connected to said flush valve which by rising tends to open the flush valve, a float tank within which said float operates, a discharge passage for said float tank, said passage having ports connecting with the flush tank, and a regulating valve adapted to control the rate of flow through said passage and ports.
- 10 4. In a flushing apparatus, the combination with a flush tank, of a flush valve, a float connected to said flush valve, a float tank within which said float operates, said float in rising tending to open the valve and in lowering tending to slowly close said flush valve, and means for controlling the discharge of water from said float tank to secure a slow refill flow after the flush.
- 15

In testimony whereof, I have hereunto set my hand.

WILLIAM H. SCHULTE.

Copies of this patent may be obtained for five cents each, by addressing the "Commissioner of Patents, Washington, D. C."