

(19) World Intellectual Property Organization
International Bureau



(43) International Publication Date
9 February 2006 (09.02.2006)

PCT

(10) International Publication Number
WO 2006/013385 A1

- (51) International Patent Classification⁷: **A61G 7/10**
- (21) International Application Number:
PCT/GB2005/003092
- (22) International Filing Date: 5 August 2005 (05.08.2005)
- (25) Filing Language: English
- (26) Publication Language: English
- (30) Priority Data:
0417453.8 5 August 2004 (05.08.2004) GB
- (71) Applicant (for all designated States except US): **MAN-GAR INTERNATIONAL LIMITED** [GB/GB]; Presteigne Industrial Estate, Presteigne, Powys LD8 2UF (GB).
- (72) Inventors; and
- (75) Inventors/Applicants (for US only): **FLETCHER, Richard** [GB/GB]; The Fold, Bircher, Leominster, Herefordshire HR6 0AX (GB). **JACKSON, Simon, Christopher** [GB/GB]; 6 Carthagena, Sutton Scotney, Winchester, Hampshire SO21 3LJ (GB).
- (74) Agents: **CHURCH, Simon** et al.; Wilson Gunn, Charles House, 148/9 Great Charles Street, Birmingham B3 3HT (GB).
- (81) Designated States (unless otherwise indicated, for every kind of national protection available): AE, AG, AL, AM, AT, AU, AZ, BA, BB, BG, BR, BW, BY, BZ, CA, CH, CN, CO, CR, CU, CZ, DE, DK, DM, DZ, EC, EE, EG, ES, FI, GB, GD, GE, GH, GM, HR, HU, ID, IL, IN, IS, JP, KE, KG, KM, KP, KR, KZ, LC, LK, LR, LS, LT, LU, LV, MA, MD, MG, MK, MN, MW, MX, MZ, NA, NG, NI, NO, NZ, OM, PG, PH, PL, PT, RO, RU, SC, SD, SE, SG, SK, SL, SM, SY, TJ, TM, TN, TR, TT, TZ, UA, UG, US, UZ, VC, VN, YU, ZA, ZM, ZW.
- (84) Designated States (unless otherwise indicated, for every kind of regional protection available): ARIPO (BW, GH, GM, KE, LS, MW, MZ, NA, SD, SL, SZ, TZ, UG, ZM, ZW), Eurasian (AM, AZ, BY, KG, KZ, MD, RU, TJ, TM), European (AT, BE, BG, CH, CY, CZ, DE, DK, EE, ES, FI, FR, GB, GR, HU, IE, IS, IT, LT, LU, LV, MC, NL, PL, PT, RO, SE, SI, SK, TR), OAPI (BF, BJ, CF, CG, CI, CM, GA, GN, GQ, GW, ML, MR, NE, SN, TD, TG).
- Published:
— with international search report

[Continued on next page]

(54) Title: DEVICE FOR ASSISTING DISABLED AND ELDERLY PERSONS

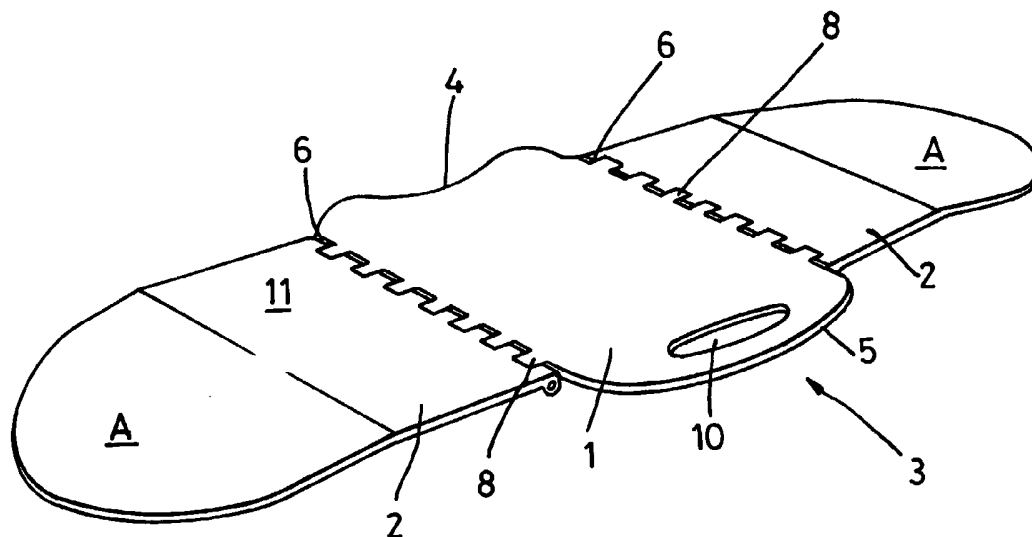

(57) Abstract: A device for assisting a person. To transfer from a sitting position on a first support to a sitting position on an adjacent support. The device comprises at least two panels connected together by connection means for movement relative to one another. At least one of said panels is arranged to co operate with the first support upon which a person is sitting and at least one other panel arranged to co operate with an adjacent support to which a person is to be transferred, said panels providing a bridging surface between the two supports and allowing transferal of a person therebetween without necessitating standing.

WO 2006/013385 A1



For two-letter codes and other abbreviations, refer to the "Guidance Notes on Codes and Abbreviations" appearing at the beginning of each regular issue of the PCT Gazette.

Device for assisting disabled and elderly persons

This invention relates to devices for assisting persons, particularly disabled and elderly persons to move from a sitting position on a support to a sitting position on another adjacent support.

The invention has been devised primarily to overcome or reduce the difficulties experienced by disabled and elderly persons in moving between a seat in a motorcar and wheelchair. However, there is no limitation in this regard as the invention is broadly applicable to the movement of persons between any combinations of support including domestic chairs, beds, motorcar seats and wheelchairs.

Various devices have previously been proposed for this purpose with bevelled or slanting edges and having a low coefficient of friction, such boards being made of wood or plastics. There are some boards selectively profiled for assisting persons to transfer between wheelchairs and car seats, however these boards, having only a single curve, do not always enable the board to fit easily around door pillars of cars and wheels and armrest structures of wheelchairs, and as such are not always practical to erect, nor easy to use.

An object of the present invention is to provide a new or improved device for assisting persons to move from a sitting position on a support to a sitting position on another, adjacent support.

A particular aim of the invention is to provide a device for assisting persons transferring from a motorcar to a wheelchair, and from a wheelchair to a motorcar.

A further particular aim is to provide a device for this purpose which can
5 be conveniently stowed on a wheelchair and is convenient to carry by hand.

According to the invention there is provided a device for assisting a person to transfer from a sitting position on a first support to a sitting position on an adjacent support, said device comprising at least two panels, connected together by a connection means for movement relative to one another, at least
10 one of said panels arranged to co operate with the support upon which a person is sitting and at least one other panel arranged to co operate with an adjacent support to which a person is to be transferred, said panels providing a bridging surface between the two supports and allowing transferral of a person therebetween without necessitating standing.

15 Preferably, the connection means is not located at, or does not pass through a central point of the device when the device is erected between said supports.

Preferably, the panels are connected by hinge means.

Preferably, the device comprises a central panel and two side
20 panels.

Preferably, a portion near the free ends of each of the side panels is angled downwards in relation to an upper surface of the panels when erected

between two supports, said angled portions assisting a secure co operation with said supports.

Preferably, one panel hinged to another has a protrusion extending over the hinge means.

5 A portion of the upper surface of the panels either side of the hinge means along which a person is transferred is inclined to form a recess for receiving the protrusion, the protrusion forming a flush surface with the upper surface of the panels when the device is in the erected position.

Alternatively, the panels have a level or substantially level upper surface
10 and a recess for receiving the protrusion.

The side panels maybe unfoldable into an erected position, ready for positioning between two support structures. In this position the panels are in a co planar or substantially co planar arrangement. The panels provide a rigid surface which is substantially smooth.

15 Preferably, a smooth surface across the hinge means is achieved by an abutment of the protrusion of one panel with the other panel.

In a further arrangement of the invention, the device preferably comprises at least one latch mechanism. Preferably, the at least one latch mechanism comprises a release means located in the transfer surface of at least
20 one of the panels.

The latch mechanism is embedded in the transfer surface of at least one panel and protrudes over the hinge joint. When the panels are unfolded ready

for use a pawl of the latch mechanism locates into a correspondingly located notch on an adjacent panel. The latch mechanisms therefore ensure that the panels either side of a hinge joint are held close together to create a smooth transfer surface, thus avoiding the need for a separate cover, or protrusion over
5 the hinge joint.

Preferably, the three panels of the device are movable relative to one another between an erected position for use of the device and a collapsed position for stowage of the device.

Preferably, one or more of the panels has at least one aperture to enable
10 the device to be easily carried. More preferably, the at least one aperture is located on the central panel.

Preferably, the configuration of the device in the erected position is such that it assists the arranging of the device between two supports around unmovable obstacles such as a door pillar of a vehicle or armrest of a wheel
15 chair which may otherwise hinder the co operation of the device with each of the supports.

More preferably, the device in the erected position is provided with one or more location sections to assist arrangement between the two supports.

The invention will now be described, by way of example, with reference
20 to the accompanying drawings in which:-

Figure 1, which includes figures 1a and 1b show two perspective views of the device embodying the invention in the erected position,

Figure 2 shows a perspective view of the device embodying the invention in the position for stowage,

Figure 3 is a cross section view of the hinge means used for connecting the panels, and

5 Figures 4a, 4b and 4c show an alternative arrangement of the connection means across the hinge joints of the device, and

Figure 5 shows a plan view of the device erected between a wheel chair and motor car seat ready for use to transfer a person.

10 Figures 1 to 5 show a device according to the invention having three panels. The same numerals have been used to represent the same features in each of figures 1 to 5.

Figure 1 shows the device with side panels 2 unfolded in the erected position ready for arrangement between two supports between which a person is to be transferred. The device 3 comprises three rigid panels, a central panel 1 and two side panels 2. The panels may be made of any rigid material, such as a plastics material. The panels have a smooth transfer surface 11 having a low coefficient of friction. Alternatively, the transfer surfaces may contain grooves parallel to the direction of transfer of the person across the device. The central panel has a back edge 4, a front edge 5 and two side edges 6. In the
15 accompanying figures, the central panel 1 is shown as having a rectangular or substantially rectangular shape, however it must be appreciated that other
20 shaped central panels would suffice. For example, a central panel having a "V"

shaped configuration such that the two side edges 6 are positioned in a convergent relationship relative to the front edge 5 such that the distance between the side edges is greater nearer to the front edge 5 with respect to the back edge 4. The side panels 2 are releasably connected to the central panel 5 by hinge means 8. In the accompanying figures the hinge means are parallel or substantially parallel to one another, however the hinge means attached to a “V” shaped panel may lie in a convergent relationship along the side edges 6 of the central panel as previously described.

The hinge means are not located at, or pass through a central point of the device 3 in the erected position. This is important, since when the device is erected between two supports and carrying a load at a central position of the device, the point of maximum stress is at a central area of the device. By having an arrangement of panels, whereby the connection means is, or are located away from the area of maximum stress, the hinge means and their attachment means maybe of a lighter construction than if they were to be used to connect panels at a central location of the device. The overall weight of the device is therefore reduced enhancing the portability of the device.

In figure 1 two location sections 14 are shown located on an edge of the device 3 enabling the device to be arranged around unmovable obstacles, such as a door pillar of a motorcar or an armrest of a wheelchair, which would otherwise hinder the co operation of the device 3 between two supports. It must be understood that the shape of the panels and orientation of the side

panels relative to the central panel may also assist in providing a configuration of the device suitable for arranging around unmovable obstacles. Depending on the dimensions of the device one or more location sections maybe located along an edge or edges of the device in the erected position to assist arrangement of the device around unmovable obstacles. The side panels 2 have narrower end portions A which are angled downwards relative to the plane of the panels of the device 3 when in the erected position to aid co operation of the side panels with support structures, between which the device is to be erected. The term angled downwards includes curvature of the side panels 2 downwards relative to the plane of the device in the erected position. An aperture 10 is located on the central panel 1 close to the front edge 5 to provide a means for carrying the device and manoeuvring it into position between two supports.

Figure 2 shows the device 3 with the side panels 2 folded across the central panel 1 in the collapsed position. In this position, the device can be easily stowed, for example on a wheelchair, or carried by a person.

Figure 3 is cross-section of the central panel 1 and a side panel 2 either side of a stiff hinge joint 13. The transfer surface 11 of each panel has an inclined portion 20 which in cross section gradually increases in height towards the hinge joint and terminates at its highest end by way of a face 23 perpendicular or substantially perpendicular to the transfer surface 11.

Portion 20 forms a recess 28 with transfer surface 11.

Alternatively, instead of the transfer surface having an inclined portion 20, the transfer surface of each panel maybe raised uniformly to the height of the face 23 of the recess 28 such that the transfer surface is level, as shown by the broken lines 30. The protrusion 18 runs along an edge 6 of the panel 1 and is mounted such that it extends over the edge 6 of the panel. The protrusion maybe made of an elastomeric material, for example rubber. The inclined portions 20 are located along the length of each panel. On central panel 1 the stiff rubber protrusion 18 is affixed in abutment with an unraised portion of the transfer surface 11 and in abutment with the face 23 of the inclined portion 20 and extending over the edge 6 of the panel. The protrusion is substantially the same thickness as the height of the faces 23 and therefore forms a flush joint on the surface of the device when in abutment with the faces. The panels can be moved into an erected position until the faces of panel edges 21 and 22 acting as stopping means abut. The panels in this position are in a co-planar or substantially co planar arrangement. When the panels are moved into the erect position a portion of the protrusion extending over the edge 6 can abut with the inclined surface 11 and/or the face 23 of the raised portion of the other panel 2. In this manner the protrusion covers the joint means preventing skin and/ or clothing of the user transferring between two adjacent panels becoming trapped in the hinge joint.

It can be appreciated that even if the protrusion is not in abutment with the face 23 of the other panel 2 as may occur when there is movement between

the panels of the device when in use, the protrusion will still provide cover over the hinge joint.

It must be appreciated that the protrusion 18 maybe attached to the side panel 2 of the device instead of the central panel 1.

5 Although not shown in figure 3, the other hinge joint of the device which connects the other side of the central panel to the other side panel is also covered by a protrusion which may be attached to the central panel or the other side panel. The surfaces of the central panel and the other side panel are inclined in the manner previously described.

10 Figures 4a, 4b and 4c show an alternative hinge arrangement comprising a latch mechanism which may be used with the device 3. Figure 4a is a plan view of the underside of the device with the side panels 2 unfolded and ready for use. Figure 4b is an end view of the device in the collapsed position taken in the direction of arrow z of figure 4a. Figure 4c is a plan view of the transfer
15 surface 11 of the device.

Referring to figure 4a, the hinge means 8 are mounted on wedge shaped mounting means 50 attached by screws located either side of the hinge joint 13. The wedge shaped mounting means assist the connection of the hinge means to the panels 1,2 and provides support for the side panels 2 when the device is
20 collapsed and panels 2 are folded inwards.

In figure 4b both the side panels 2 are folded over the central panel 1. An end portion A of one side panel 2 rests between the mounting means 50 of

the hinge joint 13 of the other panel. The end portion A of the other panel lies substantially parallel to panel 1 resting on top of the one side panel. The mounting means 50 prevents the hinges moving further open thus preventing unnecessary stress on the hinge means. The figure shows latch devices 55
5 located within a recess of the sliding surface 11. The latch device 55 comprises a spring assisted pawl. On the other side of the hinge joint 13 there are provided notches 57 for receiving and abutting with the pawl.

Figure 4c shows four latch devices 55. The latch devices are embedded within the transfer surface 11 of the device so that they are not protruding from
10 the transfer surface. Upon opening the panels from the collapsed position into the erect position, the pawl 56 locates and abuts with notch 57 (not shown) of an adjacent panel holding the panels 1 and 2 close together thus preventing the panels opening whilst the device is in use. The latch device 55 is released by pressing down on the pawl 56 at 56a.

15 Figure 5 shows the device in the erected position ready for use. Portions A of side panels 2 are arranged to co operate with a motor car seat S and a wheelchair W positioned adjacent to the seat S. The device is arranged so that obstacles such as an armrest of the wheelchair 40 or a door pillar of a motorcar 41 do not hinder the erection of the device. The device is erected for use by
20 unfolding the side panels and co operating portions A of the side panels with the seat S and wheelchair W.

A person seated in the motorcar can therefore transfer to the wheelchair by shuffling along one side panel 2, across the central panel 1 and across the other side panel 2 to the wheelchair in a sitting position without the need to stand. Likewise, a person could transfer from the wheelchair to the motor car by a similar action. Once transferred, the device can either be removed from between the person and the support transferred to. Alternatively, panels can be detached leaving part of the device (a panel) resting on the support under a person. The device can be stowed in part or whole by folding one or more side panels across the central panel. The device can then be carried or stowed in the car or on a wheelchair.

The device illustrated in the drawings is not limited in its use to assisting persons to transfer to and from a motorcar. It could be used for assisting persons to move between any support, such as a bed or chair and another chair or wheel chair.

The device according to the invention has advantages in that it is lightweight, foldable, compactable and easy to carry or stow on a wheelchair.

It is to be understood that the scope of the present invention is not to be limited by the embodiment shown in the drawings. In particular, the apparatus may be made in a wide range of sizes to suit different uses. Moreover, the invention includes any novel and inventive features disclosed herein either alone or in combination with any one or more other such features.

CLAIMS

1. A device for assisting a person to transfer from a sitting position on a first support to a sitting position on an adjacent support, said device comprising
5 at least two panels connected together by connection means for movement relative to one another, at least one of said panels arranged to co operate with the first support upon which a person is sitting and at least one other panel arranged to co operate with an adjacent support to which a person is to be transferred, said panels providing a bridging surface between the two supports
10 and allowing transferral of a person there between without necessitating standing.
2. The device according to claim 1 wherein the connection means is not located at, or does not pass through a central point of the device when the
15 device is erected between the two supports.
3. The device according to claim 1 or claim 2 wherein the connection means of the panels comprises hinge means.
- 20 4. The device according to any preceding claim comprising a central panel and two side panels.
5. The device according to any preceding claim wherein a free end portion of at least one panel is angled downwards in relation to the plane of the panels
25 when erected between two supports, said angled portion(s) assisting co operation of the device with said supports.
6. The device according to any preceding claim comprising at least one latch mechanism.

7. The device as claimed in claim 6 wherein the at least one latch mechanism comprises a release means located in the transfer surface of at least one of the panels.

5

8. The device according to any preceding claim wherein at least one panel is provided with a protrusion for co operation with an adjacent panel.

9. The device as claimed in claim 8 wherein the protrusion provides means for covering the connection means between two panels when in the erected position.

10. The device as claimed in claim 8 or claim 9 wherein the material of the protrusion comprises an elastomeric material.

15

11. The device as claimed in any one of claims 8 to 10 wherein a portion of the surface of at least one panel forms a recess for receiving the protrusion of an adjacent panel.

12. The device as claimed in claim 11 wherein the protrusion has substantially the same thickness as the depth of the recess.

13. The device according to any preceding claim wherein the transfer surfaces of the panels have a low coefficient of friction.

25

14. The device according to any preceding claim wherein the panels are movable relative to one another between an erected position for use of the device and a collapsed position for storage of the device.

15. The device according to any proceeding claim wherein one or more of the panels has at least one aperture for carrying the device.

16. The device according to claim 15 wherein the at least one aperture is
5 located on a central panel.

17. The device according to any previous claim wherein the device, when in the erected position, provides at least one location section to assist arrangement of the device between two supports.

10

18. The device as substantially described herein with the reference to the drawings in figures 1 to 5.

1/6

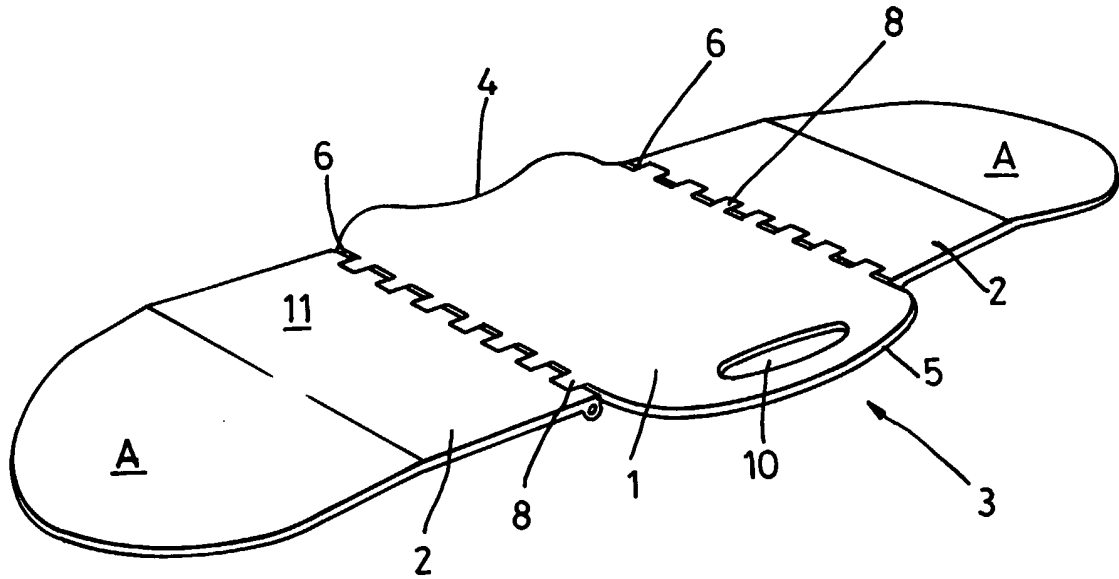

Fig. 1a

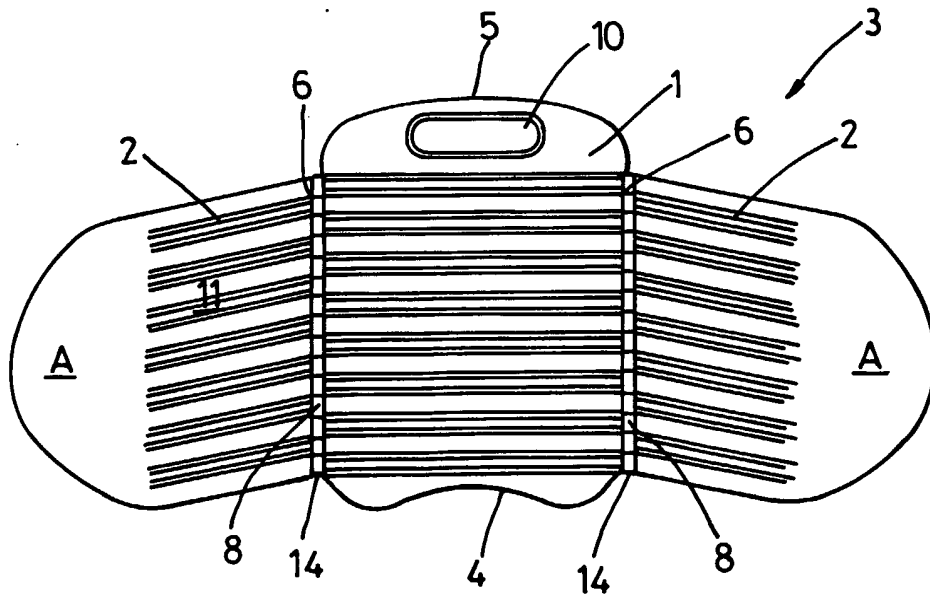

Fig. 1b

2/6

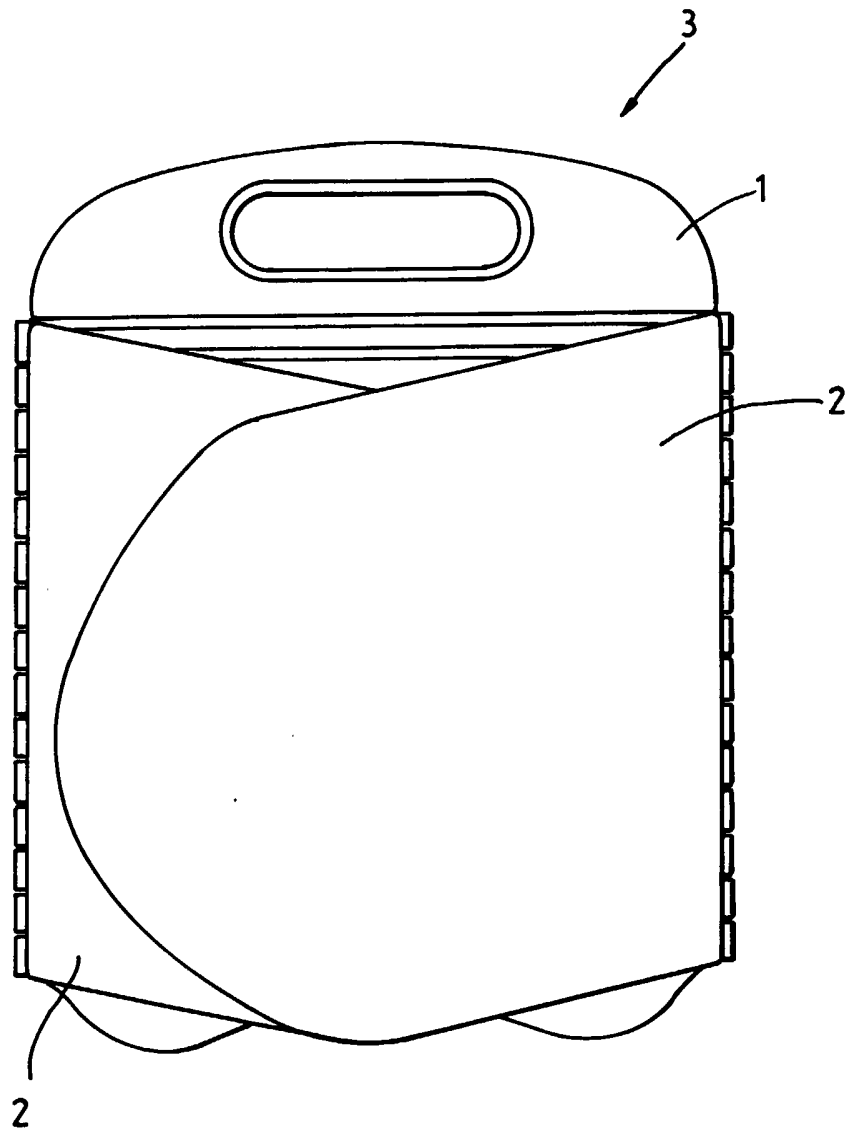

Fig. 2

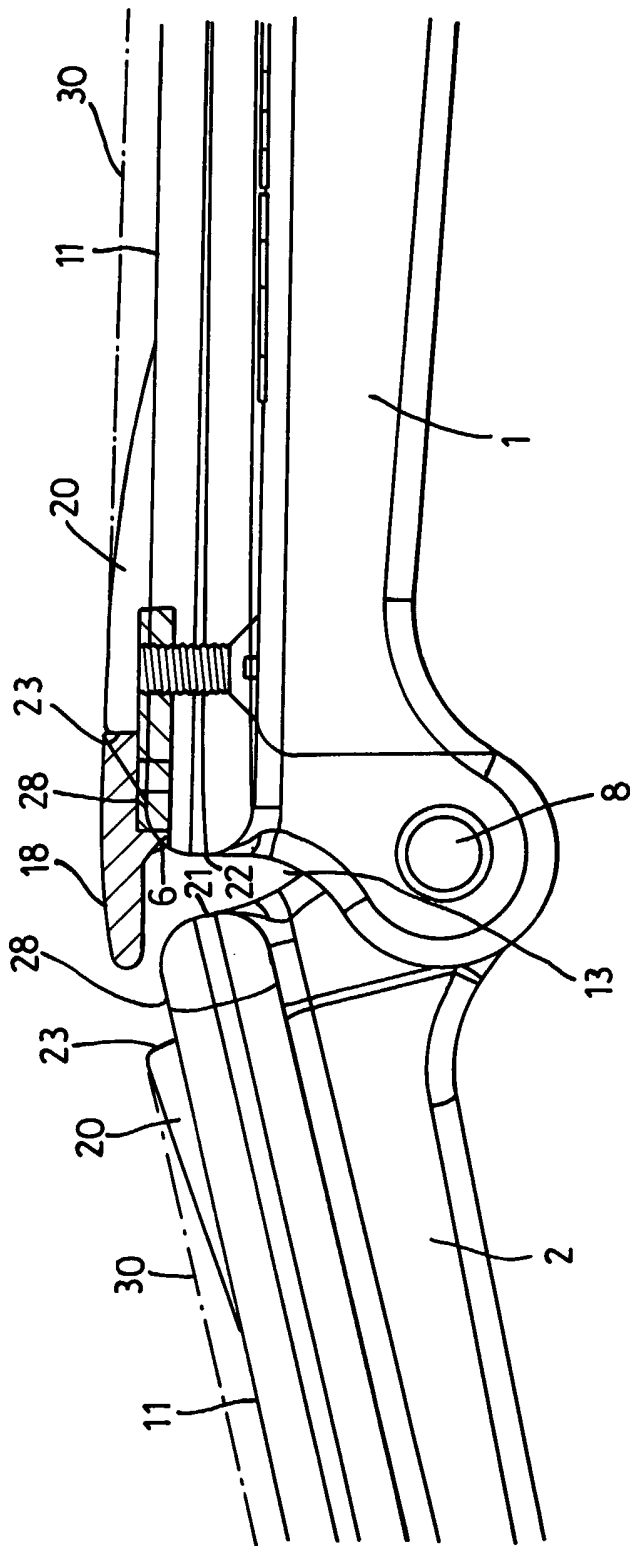

Fig. 3

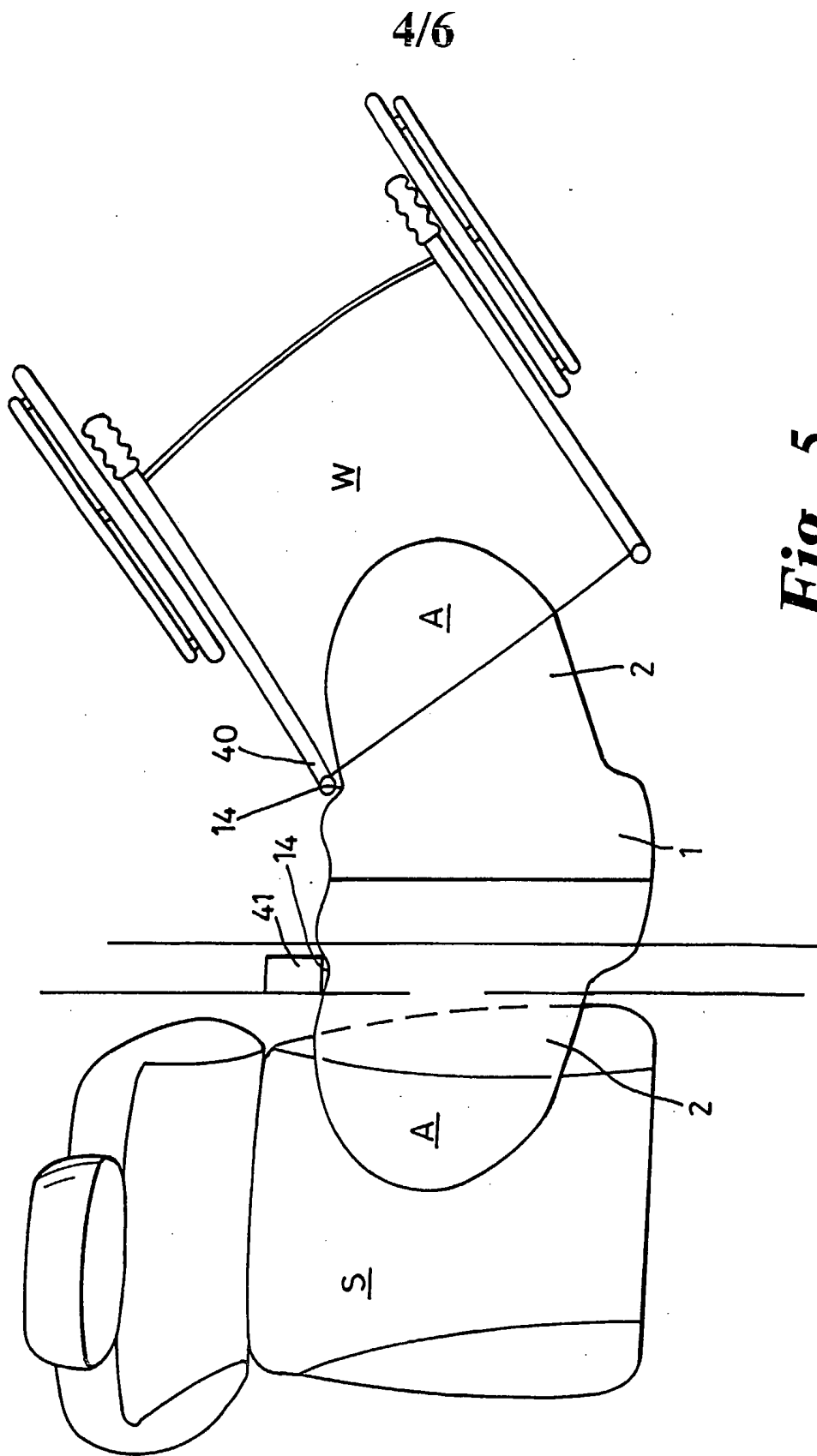

Fig. 5

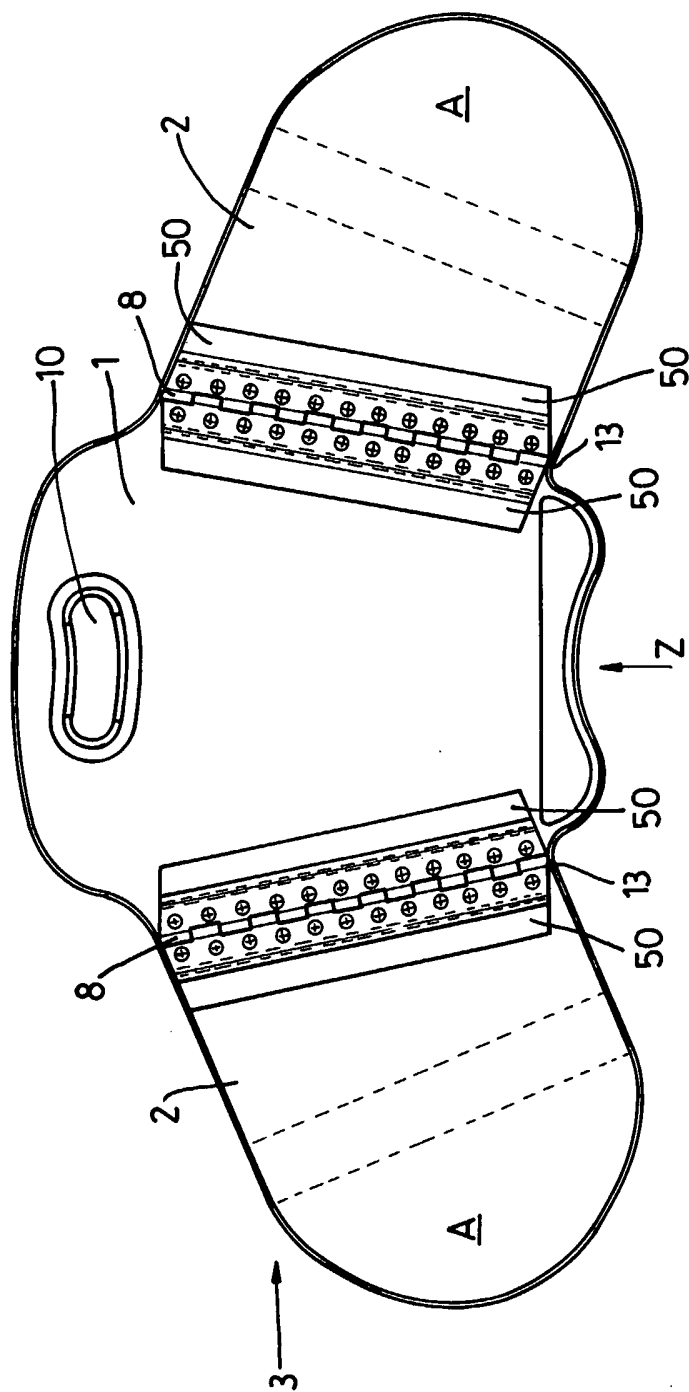

Fig. 4a

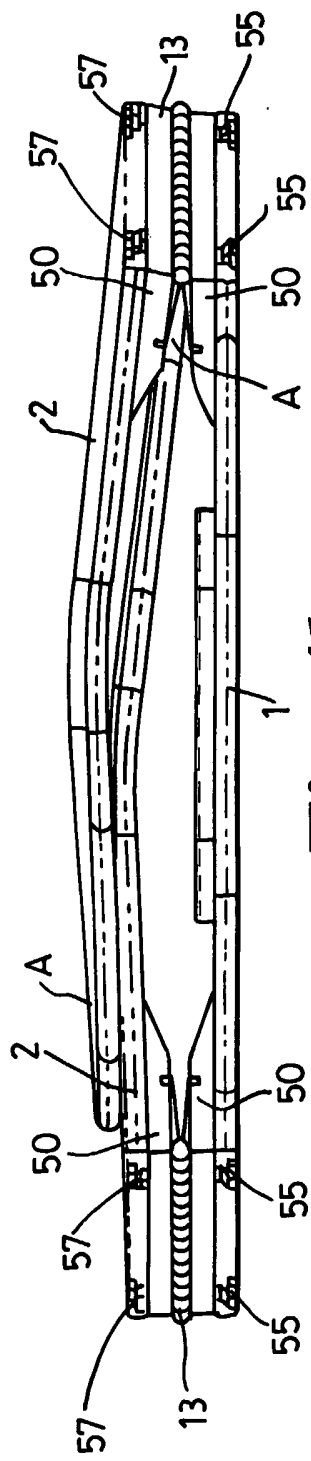

Fig. 4b

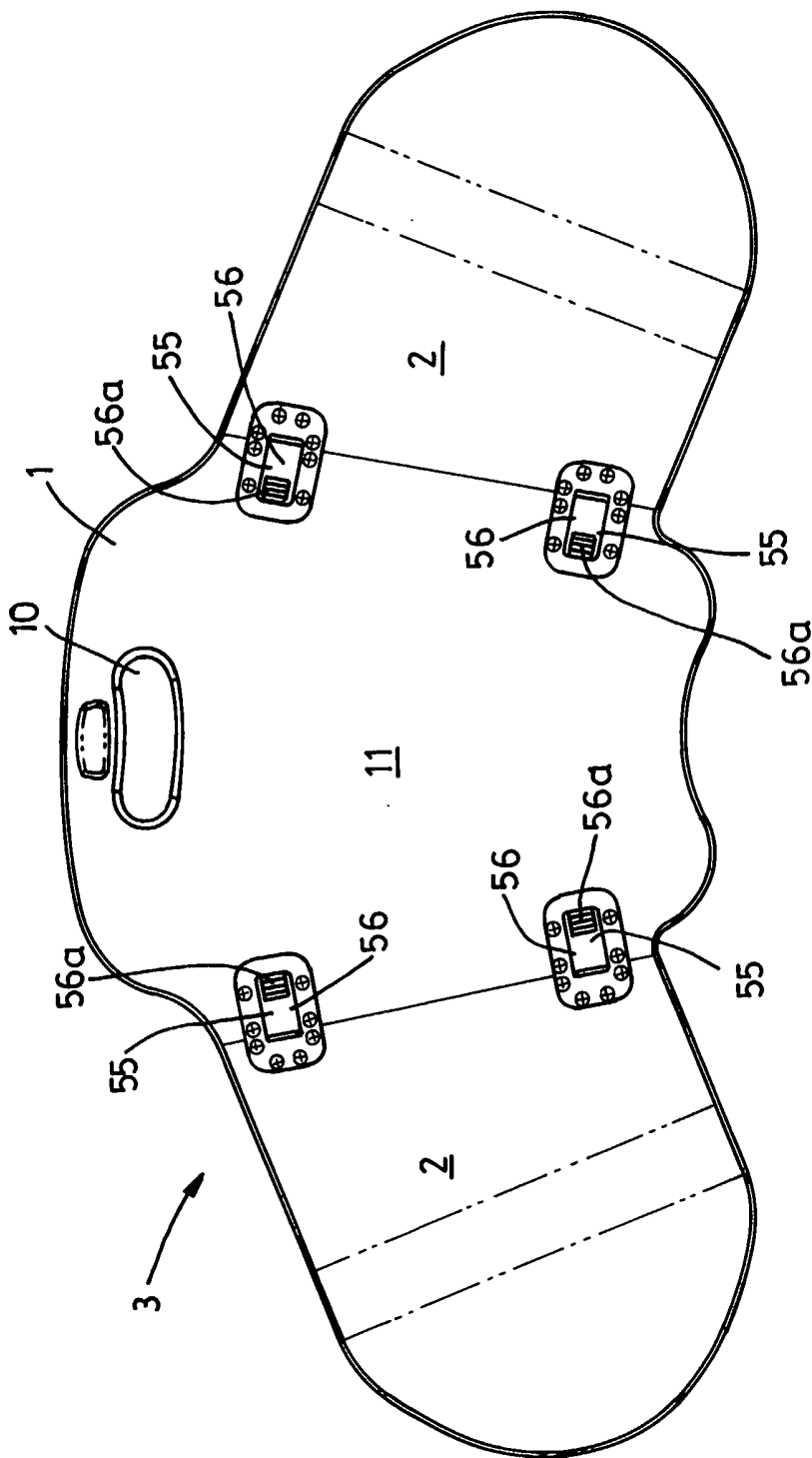

Fig. 4c

INTERNATIONAL SEARCH REPORT

International Application No

/GB2005/003092

A. CLASSIFICATION OF SUBJECT MATTER

IPC 7 A61G7/10

According to International Patent Classification (IPC) or to both national classification and IPC

B. FIELDS SEARCHED

Minimum documentation searched (classification system followed by classification symbols)

IPC 7 A61G

Documentation searched other than minimum documentation to the extent that such documents are included in the fields searched

Electronic data base consulted during the international search (name of data base and, where practical, search terms used)

EPO-Internal

C. DOCUMENTS CONSIDERED TO BE RELEVANT

Category °	Citation of document, with indication, where appropriate, of the relevant passages	Relevant to claim No.
X	GB 2 387 321 A (ROOZBEH * SHIRANDAMI; MICHAEL JOHN * BEVIS) 15 October 2003 (2003-10-15) page 3, line 27 - page 4, line 11 page 4, line 28 - page 5, line 16 figures 1-3,5	1-6, 8-14,17
X	----- GB 2 356 342 A (MARTIN JOHN * SABINE) 23 May 2001 (2001-05-23) page 3, line 11 - page 6, line 5 figures 1-4	1,3,8, 10-13, 15-17
X	----- US 4 155 588 A (DANZIGER, REUVEN ET AL) 22 May 1979 (1979-05-22) column 1, line 67 - column 2, line 65 figures 3,5,7 -----	1,3,8, 14,17

Further documents are listed in the continuation of box C.

Patent family members are listed in annex.

° Special categories of cited documents:

- *A* document defining the general state of the art which is not considered to be of particular relevance
- *E* earlier document but published on or after the international filing date
- *L* document which may throw doubts on priority claim(s) or which is cited to establish the publication date of another citation or other special reason (as specified)
- *O* document referring to an oral disclosure, use, exhibition or other means
- *P* document published prior to the international filing date but later than the priority date claimed

- *T* later document published after the international filing date or priority date and not in conflict with the application but cited to understand the principle or theory underlying the invention
- *X* document of particular relevance; the claimed invention cannot be considered novel or cannot be considered to involve an inventive step when the document is taken alone
- *Y* document of particular relevance; the claimed invention cannot be considered to involve an inventive step when the document is combined with one or more other such documents, such combination being obvious to a person skilled in the art.
- *Z* document member of the same patent family

Date of the actual completion of the international search

9 November 2005

Date of mailing of the international search report

21/11/2005

Name and mailing address of the ISA

European Patent Office, P.B. 5818 Patentlaan 2
NL - 2280 HV Rijswijk
Tel. (+31-70) 340-2040, Tx. 31 651 epo nl,
Fax: (+31-70) 340-3016

Authorized officer

Ong, H.D.

INTERNATIONAL SEARCH REPORT

International application No.
PCT/GB2005/003092

Box II Observations where certain claims were found unsearchable (Continuation of item 2 of first sheet)

This International Search Report has not been established in respect of certain claims under Article 17(2)(a) for the following reasons:

1. Claims Nos.:
because they relate to subject matter not required to be searched by this Authority, namely:

2. Claims Nos.: 18
because they relate to parts of the International Application that do not comply with the prescribed requirements to such an extent that no meaningful International Search can be carried out, specifically:
see FURTHER INFORMATION sheet PCT/ISA/210

3. Claims Nos.:
because they are dependent claims and are not drafted in accordance with the second and third sentences of Rule 6.4(a).

Box III Observations where unity of invention is lacking (Continuation of item 3 of first sheet)

This International Searching Authority found multiple inventions in this international application, as follows:

1. As all required additional search fees were timely paid by the applicant, this International Search Report covers all searchable claims.

2. As all searchable claims could be searched without effort justifying an additional fee, this Authority did not invite payment of any additional fee.

3. As only some of the required additional search fees were timely paid by the applicant, this International Search Report covers only those claims for which fees were paid, specifically claims Nos.:

4. No required additional search fees were timely paid by the applicant. Consequently, this International Search Report is restricted to the invention first mentioned in the claims; it is covered by claims Nos.:

Remark on Protest

- The additional search fees were accompanied by the applicant's protest.
- No protest accompanied the payment of additional search fees.

FURTHER INFORMATION CONTINUED FROM PCT/ISA/ 210

Continuation of Box II.2

Claims Nos.: 18

Claim 18 contains a reference to the drawings. According to Rule 6.2(a) PCT, claims should not contain such references except where absolutely necessary, which is not the case here.

The applicant's attention is drawn to the fact that claims relating to inventions in respect of which no international search report has been established need not be the subject of an international preliminary examination (Rule 66.1(e) PCT). The applicant is advised that the EPO policy when acting as an International Preliminary Examining Authority is normally not to carry out a preliminary examination on matter which has not been searched. This is the case irrespective of whether or not the claims are amended following receipt of the search report or during any Chapter II procedure. If the application proceeds into the regional phase before the EPO, the applicant is reminded that a search may be carried out during examination before the EPO (see EPO Guideline C-VI, 8.5), should the problems which led to the Article 17(2) declaration be overcome.

INTERNATIONAL SEARCH REPORT

Information on patent family members

International Application No

/GB2005/003092

Patent document cited in search report	Publication date	Patent family member(s)	Publication date
GB 2387321	A	15-10-2003	NONE
GB 2356342	A	23-05-2001	NONE
US 4155588	A	22-05-1979	NONE