

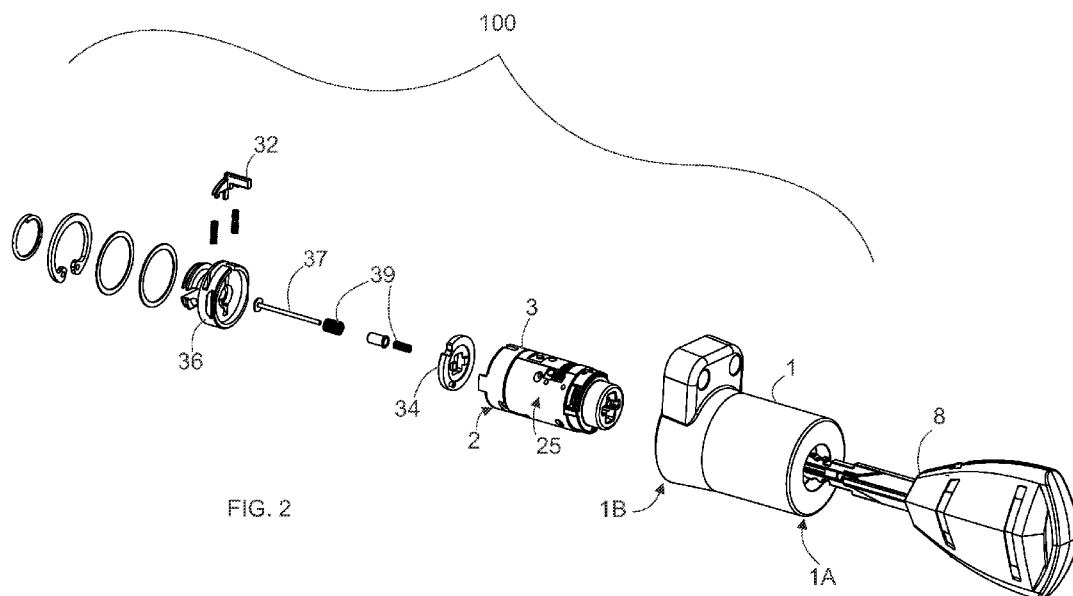

- (51) **International Patent Classification:**
E05B 47/06 (2006.01) *G07C 9/00* (2006.01)
- (21) **International Application Number:**
PCT/FI2017/050239
- (22) **International Filing Date:**
04 April 2017 (04.04.2017)
- (25) **Filing Language:** Finnish
- (26) **Publication Language:** English
- (71) **Applicant:** ABLOY OY [FI/FI]; Wahlforssinkatu 20, 80100 Joensuu (FI).
- (72) **Inventors:** KURKI, Antti; Sulkanurkka 3, 82220 Niitty-lahti (FI). HAVUKAINEN, Pauli; Alinanpolku 4, 80400 Ylämylly (FI). DAUBITZ, Matthias; Königstr. 8, 14163 Berlin (DE). WAHL, Markus; Paul-Lange-Bey-Strasse 48, 14476 POTSDAM FAHRLAN (DE).
- (74) **Agent:** BERGGREN OY; P.O. BOX 16, 00101 Helsinki (FI).
- (81) **Designated States** (unless otherwise indicated, for every kind of national protection available): AE, AG, AL, AM, AO, AT, AU, AZ, BA, BB, BG, BH, BN, BR, BW, BY, BZ, CA, CH, CL, CN, CO, CR, CU, CZ, DE, DJ, DK, DM, DO, DZ, EC, EE, EG, ES, FI, GB, GD, GE, GH, GM, GT, HN, HR, HU, ID, IL, IN, IR, IS, JP, KE, KG, KH, KN, KP, KR, KW, KZ, LA, LC, LK, LR, LS, LU, LY, MA, MD, ME, MG, MK, MN, MW, MX, MY, MZ, NA, NG, NI, NO, NZ, OM, PA, PE, PG, PH, PL, PT, QA, RO, RS, RU, RW, SA, SC, SD, SE, SG, SK, SL, SM, ST, SV, SY, TH, TJ, TM, TN, TR, TT, TZ, UA, UG, US, UZ, VC, VN, ZA, ZM, ZW.
- (84) **Designated States** (unless otherwise indicated, for every kind of regional protection available): ARIPO (BW, GH, GM, KE, LR, LS, MW, MZ, NA, RW, SD, SL, ST, SZ, TZ, UG, ZM, ZW), Eurasian (AM, AZ, BY, KG, KZ, RU, TJ, TM), European (AL, AT, BE, BG, CH, CY, CZ, DE, DK, EE, ES, FI, FR, GB, GR, HR, HU, IE, IS, IT, LT, LU, LV,

(54) **Title:** CYLINDER LOCK



(57) **Abstract:** The cylinder lock (100) according to the invention comprises a body (1) and, inside it, an inner cylinder unit (2) provided with an inner cylinder (3). The cylinder lock also comprises a generator (7) for generating electricity from the movement of a key inserted in the cylinder lock. The electricity generated is used to identify the key, and the electricity generated is also used in the electric means if opening the cylinder lock (100) is allowed on the basis of the identification of the key. In connection with the generator (7) are also generator shaft system (10), a channel axis (11) and transmission parts (12) from the channel axis to the generator.



MC, MK, MT, NL, NO, PL, PT, RO, RS, SE, SI, SK, SM,
TR), OAPI (BF, BJ, CF, CG, CI, CM, GA, GN, GQ, GW,
KM, ML, MR, NE, SN, TD, TG).

Published:

— *with international search report (Art. 21(3))*

Cylinder lock

Technical field

The present invention relates to a cylinder lock provided with electric means which
5 allow a tumbler in the cylinder lock to be guided from a locking position into an opening
position. The cylinder lock is further provided with a generator for generating electricity
from the movement of a key inserted in the cylinder lock.

Prior art

10 It is known that a cylinder lock comprises a body and, inside it, an inner cylinder unit.
The inner cylinder unit may be provided with an inner cylinder, a tumbler and electric
means. The electric means allow the tumbler to be guided from a locking position into
an opening position. The tumbler prevents the inner cylinder from being turned with
15 with respect to the body in the locking position and allows the inner cylinder to be turned
with respect to the body in the opening position. In addition, known inner cylinders
include a channel for a key.

It is also known that a cylinder lock may also comprise a generator for generating
electricity from the movement of the key inserted in the cylinder lock. The publication
WO 9918310 discloses a lock cylinder of this type. The electricity generated is used to
20 identify the key and the electricity generated is further used in the electric means if
opening the cylinder lock is allowed on the basis of the identification of the key.
Manufacturing this type of a cylinder lock is demanding since the parts must be
positioned precisely with respect to one another. The tolerances between the parts
must be small in order for a lock cylinder provided with a generator to function properly.
25 Due to these factors, manufacturing a cylinder lock is expensive and requires great
care and precision. Furthermore, the structure described above is not necessarily
applicable to all cylinder lock types.

Brief description of the invention

30 The object of the invention is to achieve a cylinder lock provided with a generator,
the manufacture of which cylinder lock is cheaper and even faster compared to known
cylinder locks. This object is achieved in the manner disclosed in the independent
claim.

The cylinder lock 100 according to the invention comprises a body 1 and, inside it,

an inner cylinder unit 2 provided with an inner cylinder 3, a tumbler 4 and electric means 5. The electric means allow the tumbler 4 to be guided from a locking position into an opening position. The tumbler 4 prevents the turning of the inner cylinder 3 with respect to the body 1 in the locking position and allows the inner cylinder to be turned with respect to the body in the opening position. There is also a channel 6 inside the inner cylinder.

The cylinder lock also comprises a generator 7 for generating electricity from the movement of the key 8 inserted in the cylinder lock. The electricity generated is used to identify the key 8, and the electricity generated is also used in the electric means 5 if opening the cylinder lock 100 is allowed on the basis of the identification of the key. In connection with the generator 7 is a generator shaft system 10. The cylinder lock also comprises a channel axis 11 and transmission parts 12 from the channel axis to the generator. The cylinder lock further comprises a key channel module 19 with a key channel 20 and an opening 21 from its side surface 20A into the key channel.

The cylinder lock also comprises a key channel module 19 with a key channel 20 and an opening 21 from its side surface 20A into the key channel. The key channel 20 and the channel 6 inside the inner cylinder form a joint channel 20, 6. In the key channel module opening 21 is positioned a part of the channel axis 11, which extends into the key channel 20. The channel axis comprises a gearwheel 22 which is in the key channel 2. The channel axis 11 is arranged to rotate by the movement of the key 8 inserted in the cylinder lock.

The generator shaft system 10, the channel axis 11, the transmission parts 12 and the key channel module 19 are, therefore, connected to the inner cylinder 3 such that they are arranged to turn with the inner cylinder.

In the cylinder lock is also located a circuit board 26 provided with a memory for identifying the key, and also for conveying the electricity generated to the electric means 5 if opening the cylinder lock is allowed on the basis of the identification of the key.

The cylinder lock also comprises at least one curved protective cover 24A, between which protective cover and the key channel module 19 are located the channel axis 11, the transmission parts 12, the generator shaft system 10 and the generator 7, as well as the key channel module 19.

It is, however, possible that the cylinder lock also comprises a second protective cover 24B, in which case the channel axis 11, the transmission parts 12, the generator shaft system 10 and the generator 7, as well as the key channel module 19 are located between the protective covers. A circuit board 26 may also be located between the

protective covers. The protective covers form sliding support surfaces 25 with respect to the body 1. The support surfaces 25 and the outer surfaces of the inner cylinder form a convergent curved surface area. The protective covers may thus be curved.

The idea of the invention is that the structure of the cylinder lock is such that the generator may be connected in conjunction with the inner cylinder, such that it rotates with the inner cylinder. This structure is applicable to several different types of lock cylinders. The structure is, in addition, relatively simple and more economical compared to earlier solutions.

10 List of figures

The invention is described in greater detail in the following, with reference to the accompanying drawing figures, wherein

- Figure 1 shows an example of a cylinder lock according to the invention as an exploded view,
- 15 Figure 2 shows an example of a cylinder lock according to the invention when partly assembled,
- Figure 3 shows an example of a generator module,
- Figure 4 shows the generator module of Fig. 3 from another angle,
- Figure 5 shows an example of a generator module as an exploded view,
- 20 Figures 6 and 7 show yet another example of a generator module,
- Figures 8 and 9 show yet another example of a generator module,
- Figures 10 to 12 show an example of a key channel module,
- Figures 13 to 14 show an example of a toothed bar located in the key channel,
- Figures 15 to 16 show an example of a front shield of the cylinder lock according to the invention,
- 25 Figures 17 to 18 show an example of an inner cylinder unit of the cylinder lock according to the invention,
- Figure 19 shows a cross-sectional view of an example of the cylinder lock according to the invention with a key,
- 30 Figure 20 shows an example of the cylinder lock according to the invention with a disc tumbler,
- Figure 21 shows an example of the cylinder lock according to the

- invention with a pin tumbler,
- Figure 22 shows an example of the cylinder lock according to the invention as an exploded view,
- Figure 23 shows certain parts of the invention in greater detail,
- 5 Figure 24 shows an example of the cylinder lock according to the invention when partly assembled, and
- Figure 25 shows an example of the cylinder lock according to the invention when assembled.

10 Description of the invention

Figure 1 shows an example of the cylinder lock 100 according to the invention as an exploded view, and figure 2 when partly assembled.

The cylinder lock 100 comprises a body 1 and, inside it, an inner cylinder unit 2 which is provided with an inner cylinder 3, a tumbler 4 and electric means 5. The
15 electric means allow the tumbler 4 to be guided from the locking position into the opening position. The tumbler 4 prevents the turning of the inner cylinder 3 with respect to the body 1 in the locking position and allows the inner cylinder to be turned with respect to the body in the opening position. Figure 20 shows a disc tumbler 4 and figure 21 a pin tumbler 4A. Inside the inner cylinder is further a channel 6.

20 The cylinder lock also comprises a generator 7 for generating electricity from the movement of the key 8 inserted in the cylinder lock. The generator is comprised in a generator module 9 which is described in greater detail below. The electricity generated is used for identifying the key 8, and the electricity generated is further used
25 in the electric means 5 if opening the cylinder lock 100 is allowed on the basis of the identification of the key.

Figures 3 and 4 show an example of a generator module. The generator module 9 thus comprises the said generator 7, the generator shaft system 10 in connection with the generator, the channel axis 11, and the transmission parts 12 from the channel axis to the generator. The generator module also includes two support plates 16A, 16B,
30 between which the generator 7, the transmission parts 12, the generator shaft system 10 and the channel axis 11 are at least partly located. In at least one of the support plates is a hole 18 for the channel axis, and the channel axis 11 is positioned through the hole 18 intended for it such that a part of the channel axis is between the support plates and a part on the opposite side of one of the support plates. The channel axis 11

is arranged to rotate by the movement of the key 8 inserted in the cylinder lock.

The generator shaft system 10, the channel axis 11, the transmission parts 12 and the key channel module 19 are thus connected to the inner cylinder 3 such that they are arranged to turn with the inner cylinder.

5 The inner cylinder unit 2 includes a control unit 28 which comprises the said channel 6 and is provided with the said electric means 5. The control unit is also arranged to turn with respect to the inner cylinder 3. The electric means may be, for example, an electric motor 29. In the cylinder lock is also located a circuit board 26 provided with a memory to identify the key and, in addition, to convey the electricity generated to the
10 electric means 5 if opening the cylinder lock is allowed on the basis of the identification of the key. Figures 17 and 18 also show an example of an inner cylinder unit.

Figure 20 shows an example of a tumbler 4 located inside the inner cylinder 3. In this example, the tumbler is a disc tumbler, but in the arrangement may also be used a pin tumbler (Figure 21). On the circumference of the disc tumbler is at least one notch
15 33 for a tumbler bar 32 (Figures 1 and 2). The example of Fig. 3 also shows how the electric motor 29 can be arranged to turn a lever 31 connected to the shaft 30 of the electric motor.

The lever 31 can be moved from a so-called neutral position into a power transmission position and vice versa. In the power transmission position, the tumbler 4
20 can be moved into an opening position, that is, in the example of Fig. 20, the lever 31 is in the edge recess 33A of the central hole of the tumbler 4. Thus, turning the key also causes the inner cylinder to turn. However, in a disc tumbler arrangement, the disc tumbler 4 turns before the inner cylinder turns such that the notch 33 on the circumference is at the tumbler bar 32. Figure 20 also shows the channel 6 in the
25 control unit 28.

Figure 21 shows an example of a solution according to the invention using a pin tumbler. In this solution, the pin tumbler 4A prevents the turning of the inner cylinder 3A with respect to the body 2A in the locking position. The pin tumbler is located both in the notch 211 in the body and in a corresponding notch in the inner cylinder. The pin
30 tumbler consists of two parts, which a spring 212 positioned in the notch 211 in the body pushes towards the inner cylinder 3A. The electric motor 29 located in conjunction with the inner cylinder 3A can be arranged to turn the lever 31 connected to the shaft 30 of the electric motor. The turning lever is able to guide the interface between the two parts of the pin tumbler to the border between the inner cylinder 3A
35 and the body 2A, whereby the pin tumbler does not prevent the inner cylinder from being turned with respect to the body. Figure 21 shows this type of a situation, that is,

where the pin tumbler is guided into the opening position by means of the electric motor 29. Figure 20 also shows the channel 6 in the inner cylinder/in its control unit 28.

In addition to a pin tumbler and a disc tumbler, it is also possible to implement other types of structures. The movement of the tumbler bar towards the centre of the cylinder lock can also be restricted or allowed, for example, by means of a separate lever/levers, which are not described in greater detail in this text. The tumbler is, therefore, not limited only to a disc or pin tumbler, but may also be some other embodiment.

Figures 1 and 2 also show that the cylinder lock comprises a rear part 36 which is connected in a non-turning manner to the inner cylinder 3. In the embodiment shown in the figures, the inner cylinder unit 2 also comprises a return tumbler disc 34 between the inner cylinder unit and the rear part 36 for returning the tumbler disc 4 to the normal position when the key is turned into the normal position. In the normal position, the key can be pulled out of the cylinder lock (and also be inserted into the lock). In both the pin tumbler embodiment and the disc tumbler embodiment, the electric means are guided into the neutral position, that is, the position in which the electric means do not guide the tumbler into the opening position or to be moved into the opening position, at the latest when the key has just been pulled out of the cylinder lock.

Figures 5 to 9 also show different embodiments of the generator module. The transmission parts 12 of the generator module 9 comprise shafts 13, 14. The generator module 9 may also comprise at least one double-flange pin 15 in some embodiments. The support plates 16A, 16B have holes 17 for the generator shaft system 10, the shafts 13, 14 and also for a possible flange pin or pins 15 or other types of pins. The mutual locations of the said holes 17 in both plates is predetermined. The double-flange pin 15 is located between the support plates 16A, 16B, while the flanges of the flange pin are against the support plates. The shafts 13, 14 and at least one flange pin 15 fix the support plates 16A, 16B to one another. From the examples can be seen that one of the said plates 16A, 16B may be smaller.

The said holes 17 in both plates have been made with a precision tool. The mutual locations of these holes are precise, and the shafts and flange pins can be placed precisely in the holes. Figures 3 and 5 show in dotted lines the distances between the holes 17, the distances thus also being precise.

Some generator module 9 embodiments may have at least one single-flange pin which acts as a shaft 13, 14 or a separate fixing pin between the plates. Double-flange and single-flange pins make the structure more robust. A more robust structure keeps its shape better and is, therefore, more durable and long-lasting. The precise mutual

locations of the parts also keep better despite aging and wear.

The shafts 13, 14 and the flanged pins (the double-flange pin or the single-flange pin) may be laser-welded or pressed to the said plates. One of the said plates 16A, 16B may be smaller, as shown in the examples in the figures. The shafts of the transmission parts are provided with gears 13A, 14A, which are between the plates 16A, 16B. There are at least two transmission part shafts. Both the size of the plates and the number of shafts are arranged as desired to make the generator module 9 suitable for the cylinder lock.

The cylinder lock according to the invention also includes a key channel module 19 with a key channel 20 and an opening 21 from its side surface 20A into the key channel. Figures 10 to 12 show an example of a key channel module. The side surface forms a mainly planar surface against the generator module 9. The key channel 20 and the channel 6 inside the inner cylinder are located on the same axis, thus forming a joint channel 20, 6. It should, however, be noted that the axes of the key channel 20 and the channel 6 may also be misaligned, for example, because the channels are asymmetrical in different ways but still form a joint channel. A part of the channel axis 11 is positioned in the key channel module opening 21 and extends into the key channel 20. The channel axis 11 comprises a gearwheel 22 which is in the key channel 20. In this way, the channel axis is arranged to rotate by the movement of the key 8 inserted in the cylinder lock in the example embodiment described above. In the key channel module may be a space 35 for an electric motor 29.

The key channel module 19 may be made of one, two or even more parts. The parts may be, for example, laser-welded together if the module is made of at least two parts.

As shown in the example of Figs 10 to 12, the key channel module 19 may be asymmetrical with respect to the key channel, such that the key channel is located in the key channel module 19, closer to side 20A on the generator module 9 side. On the other side of the key channel module may further be positioned a circuit board 26 provided with a memory for identifying the key and, in addition, to convey the electricity generated to the electric means 5 if opening the cylinder lock is allowed on the basis of the identification of the key.

The cylinder lock comprises at least one curved protective cover 24A, between which protective cover and the key channel module 19 are located the channel axis 11 the transmission parts 12, the generator shaft system 10 and the generator 7.

In one embodiment, the cylinder lock comprises curved protective covers 24A, 24B, between which the generator module 9 and the key channel module 19 are located. Between the protective covers may also be located a circuit board 26. The protective

covers form sliding support surfaces 25 with respect to the body 1. The support surfaces and the curved outer surface of the inner cylinder form a convergent curved surface area. The edges 19A of the key channel module 19 may further be curved, thus corresponding to the curvature of the outer surface of the inner cylinder.

5 The protective cover or protective covers may, therefore, be curved but they may also be of a different shape in order to protect the part/parts positioned under the protective cover/covers.

The installed generator module 9 is connected to the front shield 27 at the front part of the cylinder lock, the inner cylinder 3 and the key channel module 19. Figures 15 and 16 show an example of a front shield. The key channel module 19 includes a key channel 20 and an opening 21 from its side surface 20A into the key channel for the channel axis 11 part, as was already described above. The movement of the key is, therefore, transmitted to the channel axis and further through the transmission parts 12 to the generator 7. The generator thus generates electricity from the movement of the key. In the key channel module opening 21 is, therefore, positioned a part of the channel axis 11 which extends into the key channel 20. The channel axis 11 may comprise a gearwheel 22 which is in the key channel 20 and arranged to rotate by the movement of the key 8 inserted in the cylinder lock. The channel axis rotates also when the key is pulled out, thus causing also the generator to rotate.

20 In the embodiment shown, the cylinder lock comprises a toothed bar 23 which the key pushes when the key is inserted in the cylinder lock. Figures 13 and 14 show an example of a toothed bar. The toothed bar is located in the joint channel (20, 6) formed by the key channel and the channel (6) inside the inner cylinder. The toothed bar is also spring-loaded towards the front part 1A of the cylinder lock. The toothing of the toothed bar is against the gearwheel. Thus, the toothed bar 23 is in power transmission connection with the gearwheel 22 of the channel axis.

When the key is taken out of the cylinder lock, the spring/spring assembly in the cylinder lock pushes the toothed bar towards the front shield 27 of the cylinder lock. The front shield may consist of several parts. In an alternative embodiment, it may also be possible for the key to have a toothed section which settles against the gearwheel 22 when inserted, whereupon the movement of the key rotates the channel axis to produce electricity. As can be noted, electricity may also be generated when the key is pulled out of the cylinder lock.

As stated above, the cylinder lock comprises a rear part 36 which is connected in a non-turning manner to the inner cylinder 3. The rear part is located at the rear end 1B of the cylinder lock. The rear part may be provided with a pin 37 extending to the said

joint channel 6, 20. The toothed bar 23 has a hole 38 for the pin, and around the pin is at least one spring 39 for pushing the toothed bar towards the front part 1A of the cylinder lock. In this way, the movement of the toothed bar is more controlled. Figures 1 and 2 also show the rings used for fastening at the back of the rear part.

5 The front shield 27 of the cylinder lock may include a sensing pin 40 to indicate the normal position of the key. The key channel module may further be provided with a retainer ball 41 for keeping the key 8 inserted in the cylinder lock in the cylinder lock before pulling the key out of the cylinder lock. This type of an embodiment is shown in figure 19.

10 It is also practical to have attachment surfaces/points in the key channel module for attaching the generator module, the circuit board, the protective covers, the front shield and the cylinder unit, and, correspondingly, the generator module, circuit board, protective covers, front shield and cylinder unit may have a counter-attachment surfaces/points.

15 Figure 22 shows an exploded view of an example of another cylinder lock 100 according to the invention and figure 23 shows some parts of this embodiment in greater detail.

The cylinder lock 100 comprises a body 1 and, inside it, an inner cylinder unit 2 which is provided with an inner cylinder 3, a tumbler 4 and electric means 5. The
20 electric means allow the tumbler 4 to be guided from the locking position to the opening position. The tumbler 4 prevents the turning of the inner cylinder 3 with respect to the body 1 in the locking position and allows the inner cylinder to be turned with respect to the body in the opening position. Figure 20 shows a disc tumbler 4 and figure 21 a pin tumbler 4A. Inside the inner cylinder is further a channel 6. Figures 17 and 18 show the
25 inner cylinder unit from different angles also in this embodiment of Fig. 22.

The cylinder lock also comprises a generator 7 for generating electricity from the movement of the key 8 inserted in the cylinder lock. The electricity generated is used for identifying the key 8, and the electricity generated is further used in the electric
30 means 5 if opening the cylinder lock 100 is allowed on the basis of the identification of the key. The cylinder lock also comprises generator shaft system 10 in connection with the generator 7. The cylinder lock also comprises a channel axis 11 and transmission parts 12 from the channel axis to the generator. The channel axis 11 is arranged to rotate by the movement of the key 8 inserted in the cylinder lock. The inner cylinder unit 2 has a control unit 28 which comprises the said channel 6 and is provided with the
35 said electric means 5. The control unit is also arranged to turn with respect to the inner cylinder 3. The electric means may be, for example, an electric motor 29.

The cylinder lock also comprises a key channel module 19 with a key channel 20 and an opening 21 from its side surface 20A into the key channel. On the side surface of the key channel module are recess formations 180 for the channel axis, the transmission parts, the generator shaft system and/or the generator.

5 The key channel 20 and the channel 6 inside the inner cylinder are positioned on the same axis and thus form a joint channel 20, 6 in which the key channel module opening 21 is positioned a part of the channel axis 11, which extends into the key channel 20. The channel axis 11 comprises a gearwheel 22 which is in the key channel 2 and arranged to rotate by the movement of the key 8 inserted in the cylinder lock.

10 The generator shaft system 10, the channel axis 11, the transmission parts 12 and the key channel module 19 are, therefore, connected to the inner cylinder 3 such that they are arranged to turn with the inner cylinder.

In the cylinder lock is also located a circuit board 26 provided with a memory for identifying the key, and also for conveying the electricity generated to the electric means 5 if opening the cylinder lock is allowed on the basis of the identification of the key.

The cylinder lock also comprises at least one curved protective cover 24A, between which protective cover and the key channel module 19 are located the channel axis 11, the transmission parts 12, the generator shaft system 10 and the generator 7.

20 In one embodiment, the cylinder lock comprises curved protective covers 24AA, 24B, between which the channel axis 11, the transmission parts 12, the generator shaft system 10 and the generator 7, as well as the key channel module 19 and the circuit board 26 are located, the protective covers forming sliding support surfaces 25 with respect to the body 1, and the support surfaces 25 and the outer surfaces of the inner cylinder forming a convergent curved surface area, and which second protective cover comprises second recess formations 170 for the channel axis 11, the transmission parts 12, the generator shaft system 10 and/or the generator. As already mentioned above, the protective cover/protective covers may be curved or also of a different shape.

30 Figure 24 shows the embodiment of Fig. 22 when partly assembled, and figure 25 when completely assembled. As can be seen from the figures, the generator 7 may be preassembled with other parts (the key channel module, the circuit board) between the protective covers 24AA, 24B and connected in conjunction with the inner cylinder. No changes are necessarily required in the body 1. If the code of the key 8 inserted in the cylinder lock is correct, the inner cylinder 3 and the generator and the other parts
35 between the protective covers are able to turn with respect to the body when the

cylinder lock is opened.

Figures 20 and 21 show an embodiment with a pin tumbler and an embodiment with a disc tumbler which are also applicable to the cylinder lock in the example of Fig. 22.

Figure 22 also shows that the cylinder lock comprises a rear part 36 which is
5 connected in a non-turning manner to the inner cylinder 3. In the embodiment shown in the figures, the inner cylinder unit 2 also comprises a return tumbler disc 34 between the inner cylinder unit and the rear part 36 for returning the tumbler disc 4 into the normal position when the key is turned into the normal position. In the normal position, the key may be pulled out of the cylinder lock (and also inserted in the lock). In both the
10 pin tumbler embodiment and the disc tumbler embodiment or other embodiment, the electric means are guided into neutral, that is, to a position in which the electric means do not guide the tumbler into the opening position, or to be moved into the opening position, at the latest when the key has just been pulled out of the cylinder lock.

Figure 22 shows that the transmission parts 12 comprise shafts 13, 14. The shafts
15 of the transmission parts are provided with gears 13A, 14A. There are at least two transmission part shafts. The number of shafts is arranged as desired to fit the cylinder lock.

The cylinder lock of Fig. 22 also includes a key channel module 19 with a key channel 20 and an opening 21 from its side surface 20A into the key channel. The side
20 surface has recess formations 180 for the channel axis 11, the transmission parts 12, the generator shaft system 10 and/or the generator 7.

The key channel 20 and the channel 6 inside the inner cylinder are positioned on the same axis, thus forming a joint channel 20, 6. In the key channel module opening 21 is positioned a part of the channel axis 11, which extends into the key channel 20. The
25 channel axis comprises a gearwheel 22 which is in the key channel 20. In this way, the channel axis is arranged to rotate by the movement of the key 8 inserted in the cylinder lock in the example embodiment described above. The key channel module may have a space 35 for an electric motor 29.

On the other side of the key channel module may further be located a circuit board
30 26 provided with a memory for identifying the key, and also for conveying the electricity generated to the electric means 5, if opening the cylinder lock is allowed on the basis of the identification of the key.

The cylinder lock also comprises at least one curved protective cover 24A, between
35 which protective cover and the key channel module 19 are located the channel axis 11, the transmission parts 12, the generator shaft system 10 and the generator 7.

In one potential embodiment, the cylinder lock comprises curved protective covers 24AA, 24B, between which the generator 7 and the key channel module 19 are located. The circuit board 26 may also be located between the protective covers. The protective covers form sliding support surfaces 25 with respect to the body 1. The support surfaces 25 and the curved outer surface of the inner cylinder form a convergent curved surface area. In addition, the edges 19A of the key channel module 19 may be curved, thus corresponding to the curvature of the outer surface of the inner cylinder.

The installed generator 7 and the other parts between the protective covers are connected to the front shield 27 at the front part of the cylinder lock and to the inner cylinder 3. Figures 15 and 16 show an example of a front shield. As can be seen, the front shield 27 may be assembled of several parts. The key channel module 19 includes a key channel 20 and an opening 21 from its side surface 20AA into the key channel for the channel axis 11 part, as already mentioned above. The movement of the key is, therefore, transmitted to the channel axis and further through the transmission parts 12 to the generator 7. The generator thus generates electricity from the movement of the key. When assembled, in the key channel module opening 21 is, therefore, positioned a part of the channel axis 11 which extends into the key channel 20. The channel axis 11 may comprise a gearwheel 22 which is in the key channel 20 and arranged to rotate by the movement of the key 8 inserted in the cylinder lock. The channel axis rotates also when the key is pulled out, thus causing also the generator to turn.

Also in this embodiment, the cylinder lock comprises a toothed bar 23 which the key pushes when the key is inserted in the cylinder lock, as described above. Figures 13 and 14 show a toothed bar also for this embodiment. The key is removed from the cylinder lock as described above. Also in the embodiment of Fig. 22, it may be possible that the key has a toothed section which settles against the gearwheel 22 when inserted. The embodiment of Fig. 22 comprises a similar rear part 36 as the embodiment of Fig. 1. The structures of the front shield 27, the attachment surfaces/points and counter-attachment surfaces/points described above may also correspond to each other in both of the embodiments described above.

The solution according to the invention makes it possible to fit a generator to be connected to an inner cylinder such that the parts in conjunction with the generator, including the protective covers, form a cylindrical structure. This cylindrical structure can, in turn, be connected to the inner cylinder unit of the cylinder lock, such that it rotates either with the inner cylinder (such as the pin tumbler embodiments) and/or with the control unit 28 of the inner cylinder unit (such as the disc tumbler embodiments).

The structure can also be connected to the front shield 27 and also fits inside the cylinder lock body 1, where it is able to turn with the inner cylinder with respect to the body when the tumbler (for example, a disc tumbler or a pin tumbler) of the inner cylinder unit does not prevent the turning. The structure according to the invention is, therefore, applicable for use in cylindrical lock bodies 1 and, in practice, no major, or any, modifications need to be made in the body 1. Due to this, the invention is applicable to various cylinder lock types and is relatively cost-effective to manufacture.

In addition, the solution according to the invention allows sheet-like structures to be fitted together to form a cylindrical structure. This cylindrical structure can, in turn, be connected to the inner cylinder unit of the cylinder lock such that it rotates either with the inner cylinder (such as the pin tumbler embodiments) and/or with the control unit 28 of the inner cylinder unit (such as the disc tumbler embodiments). The cylindrical structure made of sheet-like structures can also be connected to the front shield and also fits inside the cylinder lock body 1, where it is able to turn with the inner cylinder with respect to the body when the tumbler (for example, a disc tumbler or a pin tumbler) of the inner cylinder unit does not prevent the turning. The structure according to the invention is, therefore, applicable for use in cylindrical lock bodies 1 and, in practice, no major, or any, modifications need to be made in the body 1. This type of structure is also well suited for use in different cylinder lock types (e.g. DIN cylinders or Nordic cylinders).

The generator module according to the invention may be made, for example, in advance, in which case the actual assembly stage of the cylinder lock is simpler and quicker. In addition, manufacturing the generator module with small tolerances to achieve the precision requirements is simpler and cheaper than in earlier solutions. When the generator module is made to meet the precision requirements, for the other parts of the cylinder lock the precision requirements may be lower, thus reducing manufacturing costs. Furthermore, the generator module can be connected to the inner cylinder in such a way that it rotates with the inner cylinder when the lock cylinder is opened with a key. This type of structure is, in addition suitable for use with different lock cylinder types.

In the light of the above examples, it is obvious that the embodiment according to the invention can be achieved in many ways. It is clear that the invention is not limited merely to the examples disclosed in this text, but the invention may be implemented in various embodiments. Any inventive embodiment can, therefore, be implemented within the scope of the main claim.

Claims

1. A cylinder lock (100), comprising a body (1) and, inside it, an inner cylinder unit (2) provided with an inner cylinder (3), a tumbler (4) and electric means (5), which electric means allow the tumbler (4) to be guided from a locking position into an opening position, the tumbler (4) preventing the turning of the inner cylinder (3) with respect to the body (1) in the locking position and allowing the inner cylinder to be turned with respect to the body in the opening position, the inner cylinder having a channel (6) inside it,

the cylinder lock comprising a generator (7) for generating electricity to the cylinder lock from the movement of a key (8) inserted in the cylinder lock, the electricity generated being used to identify the key (8), and the electricity generated also being used in the electric means (5) if opening the cylinder lock (100) is allowed on the basis of the identification of the key, **characterised** in that

the cylinder lock comprises, in connection with the generator (7), generator shaft system (10), a channel axis (11) and transmission parts (12) from the channel axis to the generator, and a key channel module (19) with a key channel (20) and an opening (21) from its side surface (20A) into the key channel, the key channel (20) and the channel (6) inside the inner cylinder forming a joint channel (20, 6), in which key channel module opening (21) is positioned a part of the channel axis (11), which extends into the key channel (20), and which channel axis (11) comprises a gearwheel (22) which is in the key channel (20) and arranged to rotate by the movement of the key (8) inserted in the cylinder lock,

the generator shaft system (10), the channel axis (11), the transmission parts (12) and the key channel module (19) being in connection with the inner cylinder (3) such that they are arranged to turn with the inner cylinder,

and the cylinder lock comprises a circuit board (26) provided with a memory for identifying the key, and also for conveying the electricity generated to the electric means (5) if opening the cylinder lock is allowed on the basis of the identification of the key,

and which cylinder lock comprises at least one protective cover (24A), between which protective cover and the key channel module (19) are located the channel axis (11), the transmission parts (12), the generator shaft system (10) and the generator (7).

2. A cylinder lock according to claim 1, **characterised** in that it comprises a generator module (9) which comprises the said generator and two support plates (16A, 16B), between which the generator (7), the transmission parts (12), the generator shaft

system (10) and the channel axis (11) are at least partly located, and in at least one of the support plates is a hole (18) for the channel axis, and the channel axis (11) is positioned through the hole (18) intended for it such that a part of the channel axis is between the support plates and a part on the opposite side of one of the support plates,

and the side surface of the key channel module (9) forms a mainly planar surface against the generator module (9), and which generator module is between curved protective covers.

3. A cylinder lock according to claim 2, **characterised** in that transmission parts (12) of the generator module (9) comprise shafts (13, 14), and the generator module (9) also comprises at least one double-flange pin (15), and which support plates (16A, 16B) have holes (17) for the generator shaft system (10), the shafts (13, 14) and for at least one flange pin (15), the mutual location of the said holes (17) in both plates being predetermined, and the flange pin (15) is located between the support plates (16A, 16B), while the flanges of the flange pin are against the support plate, the axes (13, 14) and at least one flange pin (15) fixing the support plates (16A, 16B) to one another.

4. A cylinder lock according to claim 2 or 3, **characterised** in that the said holes (17) in both plates have been made with a precision tool.

5. A cylinder lock according to claim 3 or 4, **characterised** in that the generator module (9) comprises at least one single-flange pin which acts as a shaft (13, 14) or a separate fixing pin between the plates.

6. A cylinder lock according to claim 4 or 5, **characterised** in that the shafts (13, 14) and at least one double-flanged pin (15) are laser-welded or pressed to the said plates.

7. A cylinder lock according to any of the claims 2 to 6, **characterised** in that one of the said plates (16A, 16B) is smaller.

8. A cylinder lock according to any of the claims 2 to 7, **characterised** in that the key channel module (19) is asymmetrical with respect to the key channel, such that the key channel is located in the key channel module (19) closer to the side (20A) on the generator module (9) side.

9. A cylinder lock according to any of the claims 2 to 8, **characterised** in that a toothed bar (23) is located in the joint channel (20, 6) formed by the key channel and the channel (6) inside the inner cylinder, the toothed bar being spring-loaded towards the front part (1A) of the cylinder lock, the toothed bar (23) being in power transmission connection with the gearwheel (22) of the channel axis.

10. A cylinder lock according to any of the claims 2 to 9, **characterised** in that at the

front part of the cylinder lock is a front shield (27) which is connected to the key channel module.

11. A cylinder lock according to any of the claims 2 to 10, **characterised** in that the shafts of the transmission parts are provided with gears (13A, 14A), which are between
5 the plates (16A, 16B).

12. A cylinder lock according to claim 11, **characterised** in that there are at least two shafts of the transmission parts.

13. A cylinder lock according to any of the claims 2 to 12, **characterised** in that the inner cylinder unit includes a control unit (28) which comprises the said channel (6) and
10 is provided with the said electric means (5) and arranged to turn with respect to the inner cylinder (3).

14. A cylinder lock according to claim 13, **characterised** in that the electric means (5) is an electric motor (29) and its shaft (30), to which shaft is connected a lever (31) which can be moved by the electric motor from the neutral position into a power
15 transmission position and vice versa, in which power transmission position the tumbler (4) can be moved into the opening position.

15. A cylinder lock according to claim 14, **characterised** in that the cylinder lock further comprises a tumbler bar (32), and the said tumbler (4) is a disc tumbler, on the circumference of which is a notch (33) for the tumbler bar.

16. A cylinder lock according to claim 15, **characterised** in that the inner cylinder unit (2) also comprises a return tumbler disc (34) for returning the tumbler disc to the
20 normal position when the key is turned into the normal position.

17. A cylinder lock according to any of the claims 2 to 12, **characterised** in that the said tumbler is a pin tumbler (4A) and the electric means is an electric motor (29) and
25 its shaft (30), to which shaft is connected a lever (31) which can be moved from the neutral position into a power transmission position and vice versa, in which power transmission position the pin tumbler has moved into the opening position.

18. A cylinder lock according to any of the claims 2 to 17, **characterised** in that the circuit board (26) is located on one side of the key channel module, between the
30 protective covers.

19. A cylinder lock according to any of the claims 2 to 18, **characterised** in that the other side of the key channel module (19) towards the circuit board (26) is mainly planar.

20. A cylinder lock according to claim 19, **characterised** in that the edges (19A) of

the key channel module (19) are curved, corresponding to the curvature of the outer surface of the inner cylinder.

21. A cylinder lock according to any of the claims 14 to 17, **characterised** in that the key channel module has a space (35) for the electric motor (29).

5 22. A cylinder lock according to any of the claims 9 to 10, **characterised** in that the cylinder lock comprises a rear part (36) which is connected in a non-turning manner to the inner cylinder (3), and which rear part is provided with a pin (37) extending to the said joint channel (6, 20), and which toothed bar (23) has a hole (38) for the pin and around the pin is at least one spring (39) for pushing the toothed bar towards the front
10 part (1A) of the cylinder lock.

23. A cylinder lock according to any of the claims 2 to 22, **characterised** in that the front shield has a sensing pin (40) to indicate the normal position of the key.

24. A cylinder lock according to any of the claims 2 to 23, **characterised** in that the key channel module includes a retainer ball 41 for keeping the key (8) inserted in the
15 cylinder lock in the cylinder lock before pulling the key out of the cylinder lock.

25. A cylinder lock according to any of the claims 2 to 24, **characterised** in that the key channel module has attachment surfaces/points for attaching the generator module, the circuit board, the protective covers, the front shield and the cylinder unit; and the generator module, circuit board, protective covers, front shield and cylinder unit
20 have counter-attachment surfaces/points.

26. A cylinder lock according to claim 1, **characterised** in that on the side surface of the key channel module are recess formations (180) for the channel axis, the transmission parts, the generator shaft system and/or the generator, and in which second protective cover are second recess formations (170) for the channel axis (11),
25 the transmission parts (12), the generator shaft system (10) and/or the generator (7).

27. A cylinder lock according to claim 26, **characterised** in that the transmission parts (12) comprise shafts (13, 14), which shafts are provided with gears (13A, 14A).

28. A cylinder lock according to any of the claims 26 to 27, **characterised** in that a toothed bar (23) is located in the joint channel (20, 6) formed by the key channel and the channel (6) inside the inner cylinder, the toothed bar being spring-loaded towards
30 the front part (1A) of the cylinder lock, the toothed bar (23) being in power transmission connection with the gearwheel (22) of the channel axis.

29. A cylinder lock according to any of the claims 26 to 28, **characterised** in that at the front part of the cylinder lock is a front shield (27) which is connected to the key
35 channel module.

30. A cylinder lock according to any of the claims 26 to 29, **characterised** in that there are at least two shafts of the transmission parts shafts.

31. A cylinder lock according to any of the claims 26 to 30, **characterised** in that the inner cylinder unit includes a control unit (28) which comprises the said channel (6) and is provided with the said electric means (5) and arranged to turn with respect to the inner cylinder (3).

32. A cylinder lock according to claim 31, **characterised** in that the electric means (5) is an electric motor (29) and its shaft (30), to which shaft is connected a lever (31) which can be moved by the electric motor from the neutral position into a power transmission position and vice versa, in which power transmission position the tumbler (4) can be moved into the opening position.

33. A cylinder lock according to claim 32, **characterised** in that the cylinder lock further comprises a tumbler bar (32), and the said tumbler (4) is a disc tumbler, on the circumference of which is a notch (33) for the tumbler bar.

34. A cylinder lock according to claim 33, **characterised** in that the inner cylinder unit (2) also comprises a return tumbler disc (34) for returning the tumbler disc to the normal position when the key is turned into the normal position.

35. A cylinder lock according to any of the claims 26 to 30, **characterised** in that the said tumbler is a pin tumbler (4A) and the electric means is an electric motor (29) and its shaft (30), to which shaft is connected a lever (31) which can be moved from the neutral position into a power transmission position and vice versa, in which power transmission position the pin tumbler has moved into the opening position.

36. A cylinder lock according to any of the claims 26 to 35, **characterised** in that the circuit board (26) is located on the other side of the key channel module, the other side towards the circuit board (26) being mainly planar.

37. A cylinder lock according to claim 36, **characterised** in that the edges (19A) of the key channel module (19) are curved, corresponding to the curvature of the outer surface of the inner cylinder.

38. A cylinder lock according to any of the claims 32 to 35, **characterised** in that the key channel module has a space (35) for the electric motor (29).

39. A cylinder lock according to any of the claims 26 to 38, **characterised** in that the cylinder lock comprises a rear part (36) which is connected in a non-turning manner to the inner cylinder (3), and which rear part is provided with a pin (37) extending to the said joint channel (6, 20), and which toothed bar (23) has a hole (38) for the pin, and around the pin is at least one spring (39) for pushing the toothed bar towards the front

part (1A) of the cylinder lock.

40. A cylinder lock according to any of the claims 26 to 39, **characterised** in that the front shield has a sensing pin (40) to indicate the normal position of the key.

41. A cylinder lock according to any of the claims 26 to 40, **characterised** in that the
5 key channel module includes a retainer ball 41 for keeping the key (8) inserted in the cylinder lock in the cylinder lock before pulling the key out of the cylinder lock.

42. A cylinder lock according to any of the claims 26 to 41, **characterised** in that the key channel module has attachment surfaces/points for attaching the generator module, the circuit board, the protective covers, the front shield and the cylinder unit;
10 and the circuit board, protective covers, front shield and cylinder unit have counter-attachment surfaces/points.

43. A cylinder lock according to any of the claims 1 to 42, **characterised** in that the cylinder lock also comprises a second protective cover (24B), between which protective covers (24A, 24B) are located the channel axis (11), the transmission parts (12), the
15 generator shaft system (10) and the generator (7), as well as the key channel module (19).

44. A cylinder lock according to claim 43, **characterised** in that the protective covers form sliding support surfaces (25) with respect to the body (1), and the support surfaces (25) and the outer surfaces of the inner cylinder form a convergent curved
20 surface area.

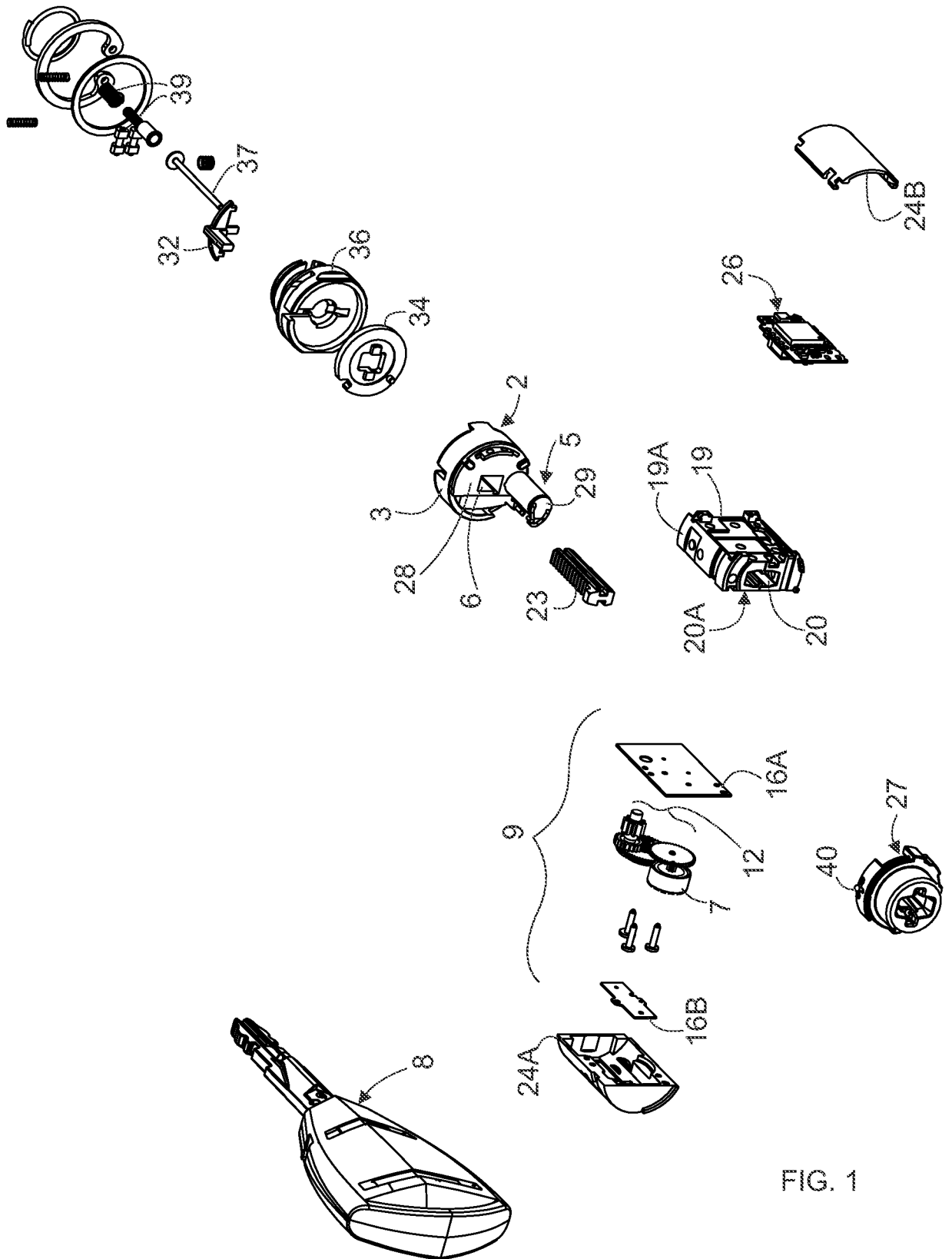

FIG. 1

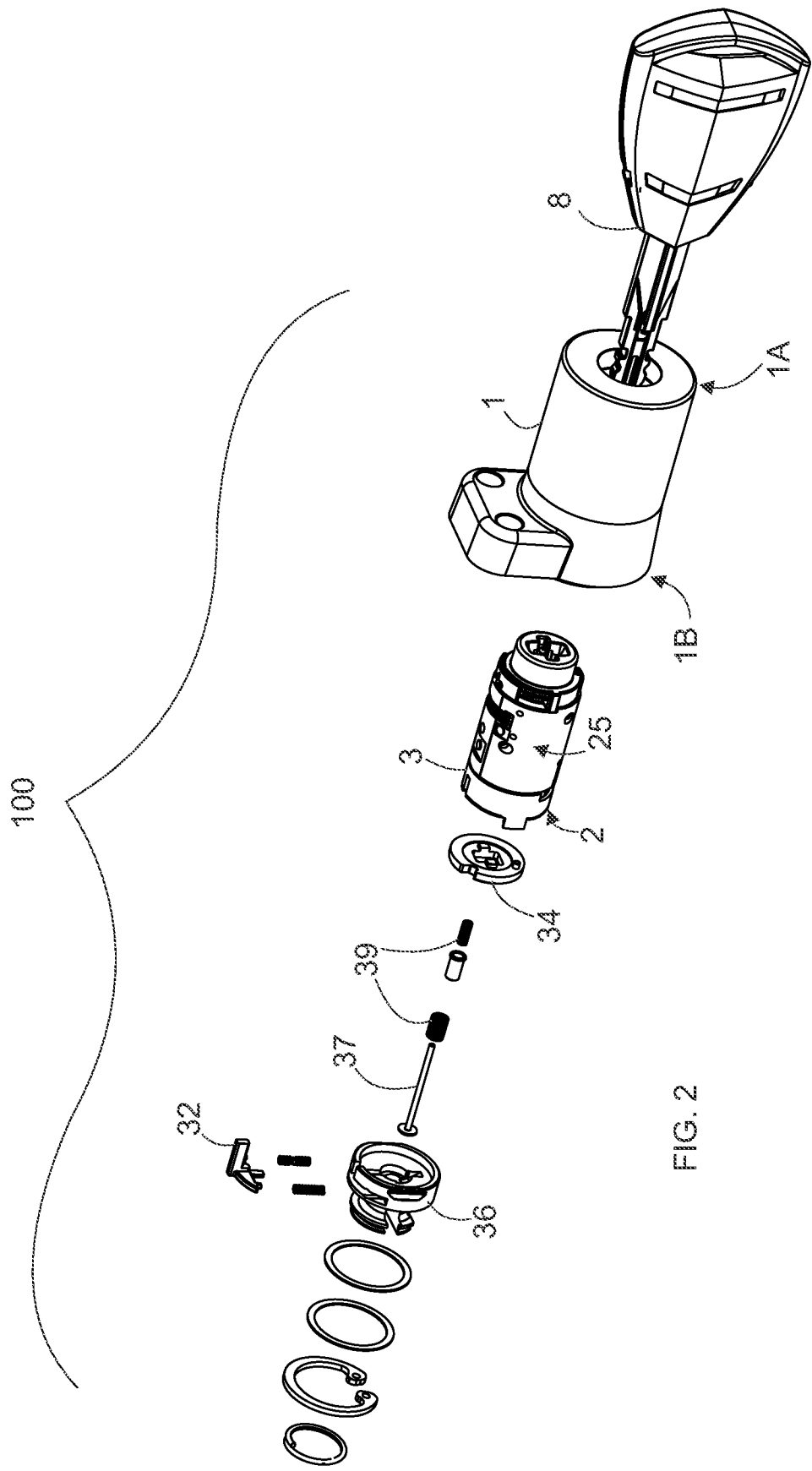
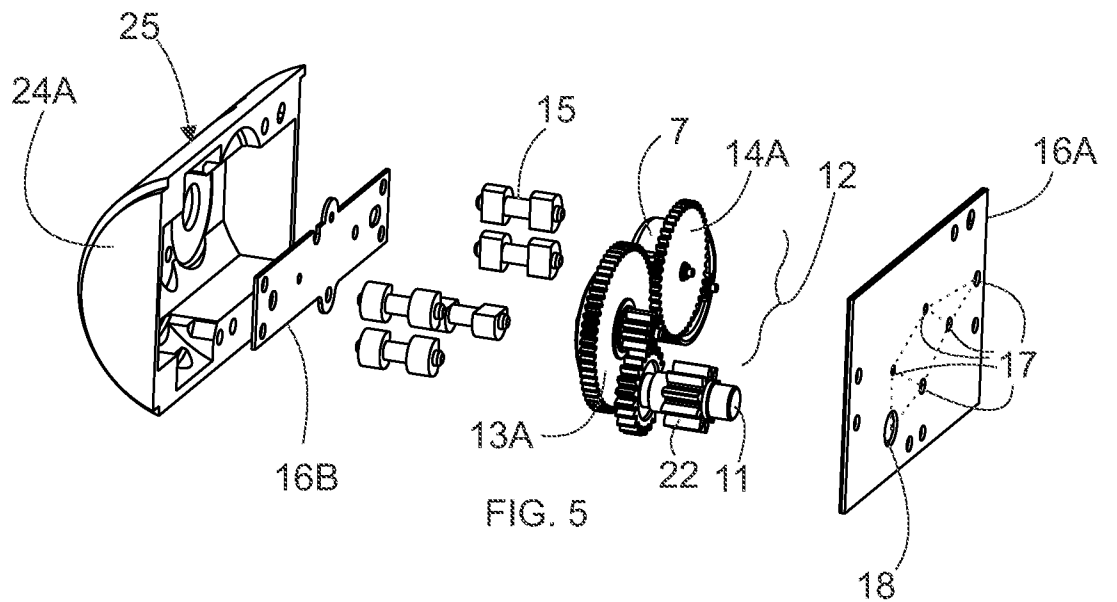
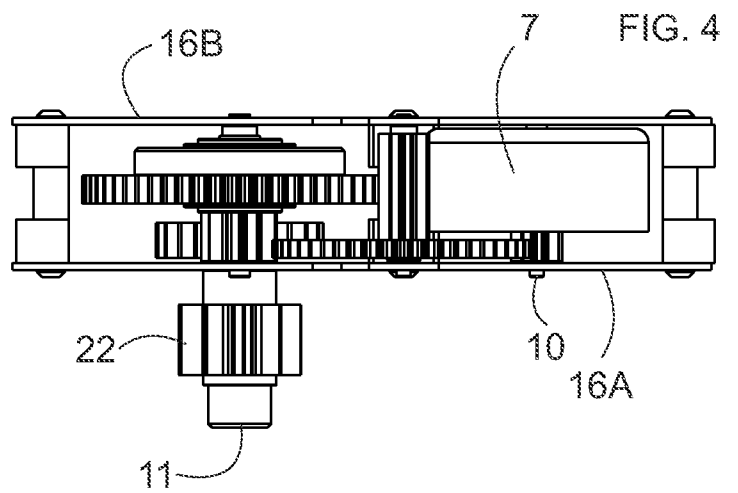
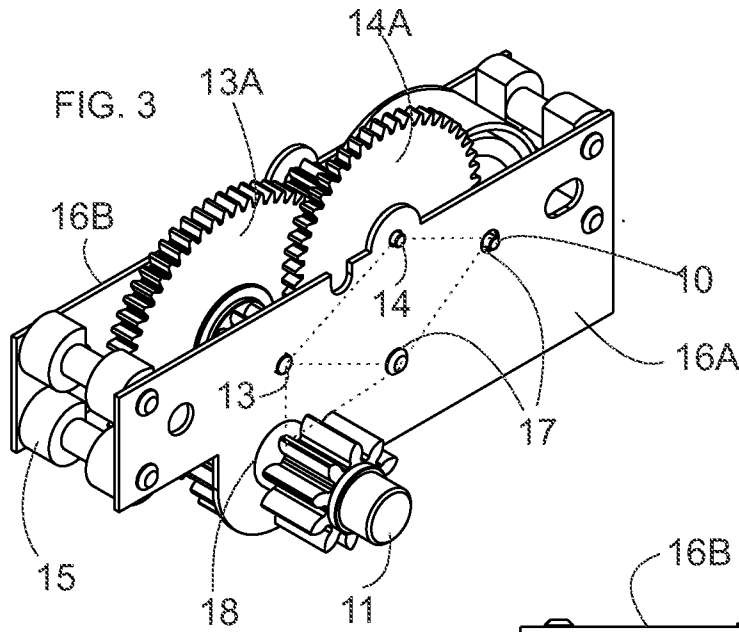

FIG. 2



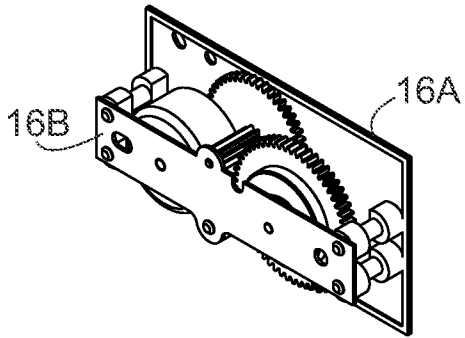

FIG. 6

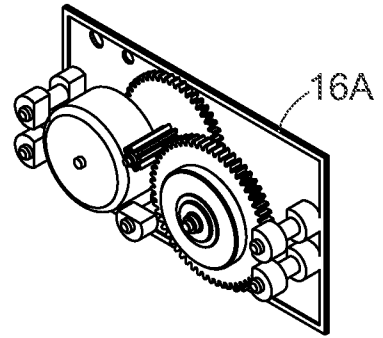

FIG. 7

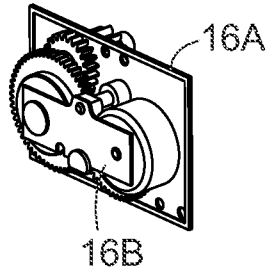

FIG. 8

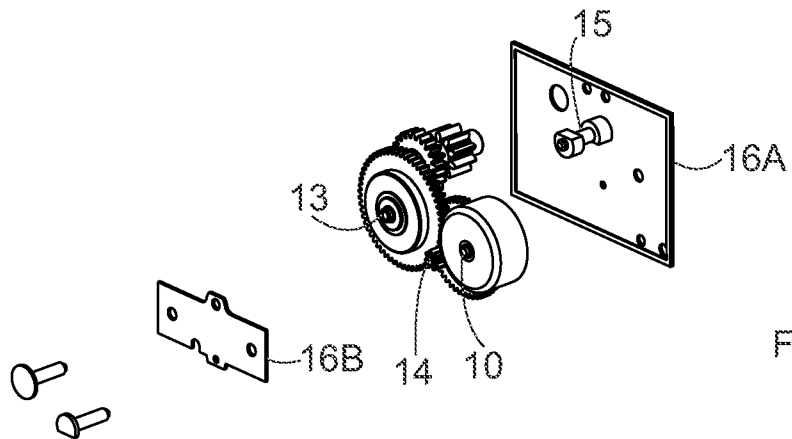

FIG. 9

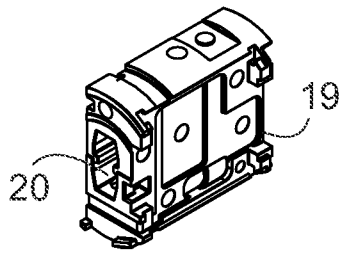

FIG. 10

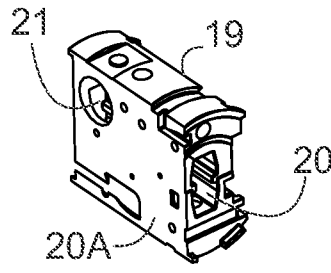

FIG. 11

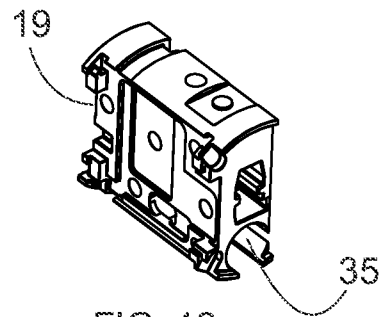

FIG. 12

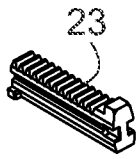

FIG. 13

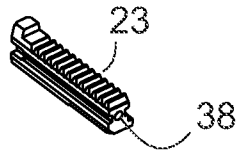

FIG. 14

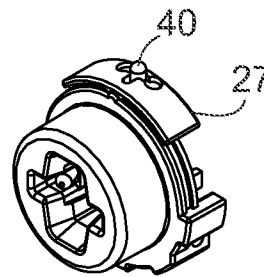

FIG. 15

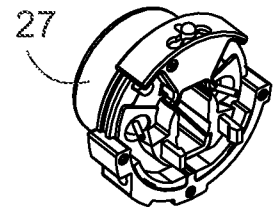

FIG. 16

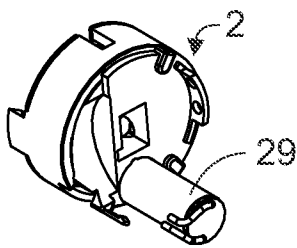

FIG. 17

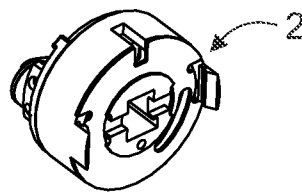

FIG. 18

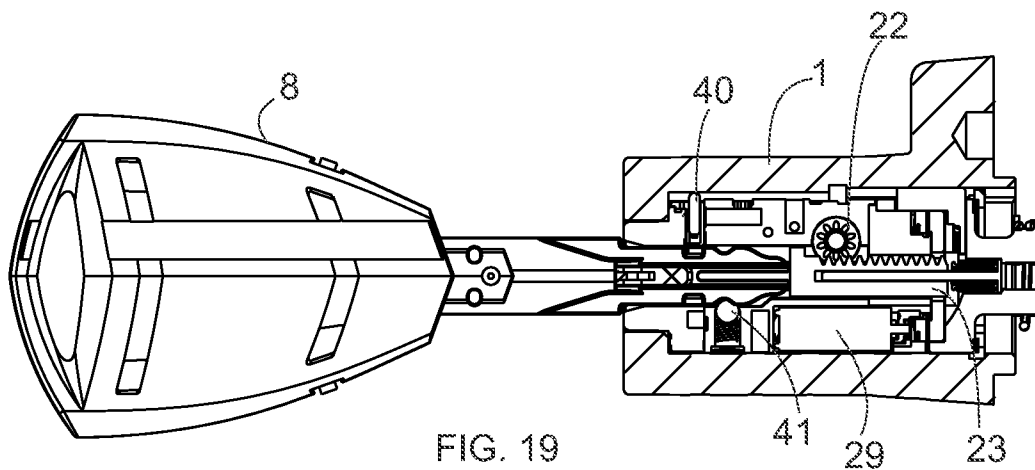

FIG. 19

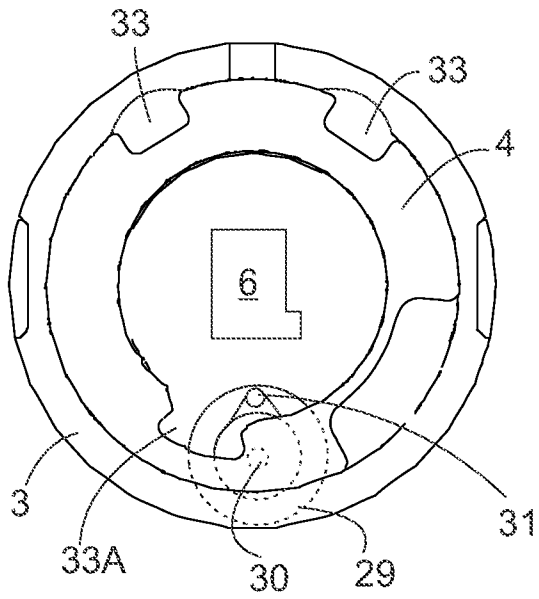

FIG. 20

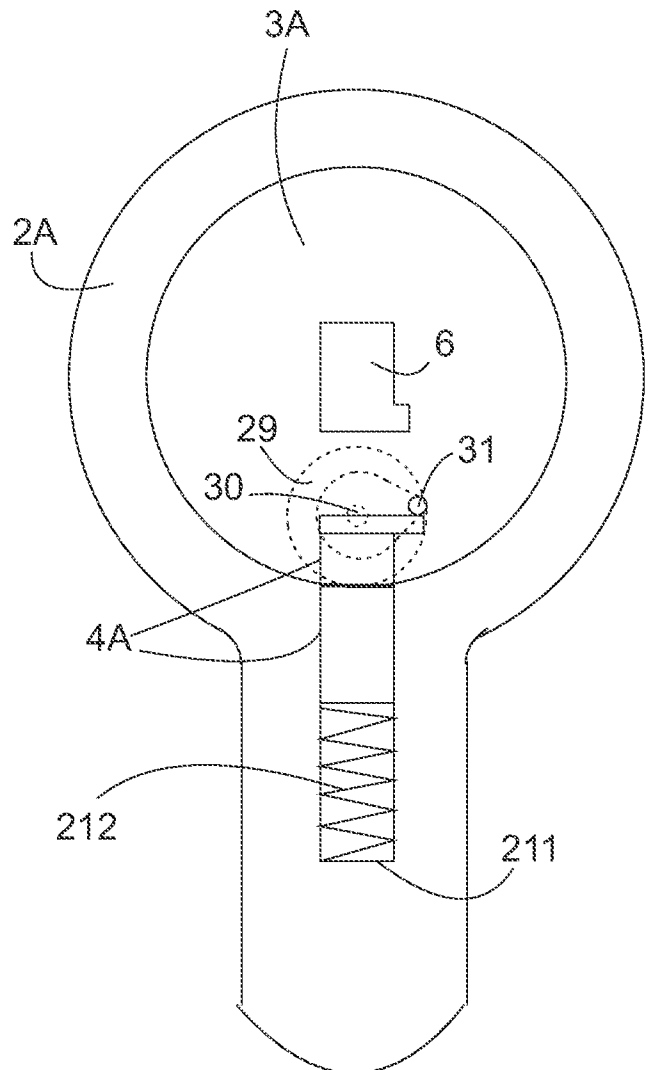

FIG. 21

7/8

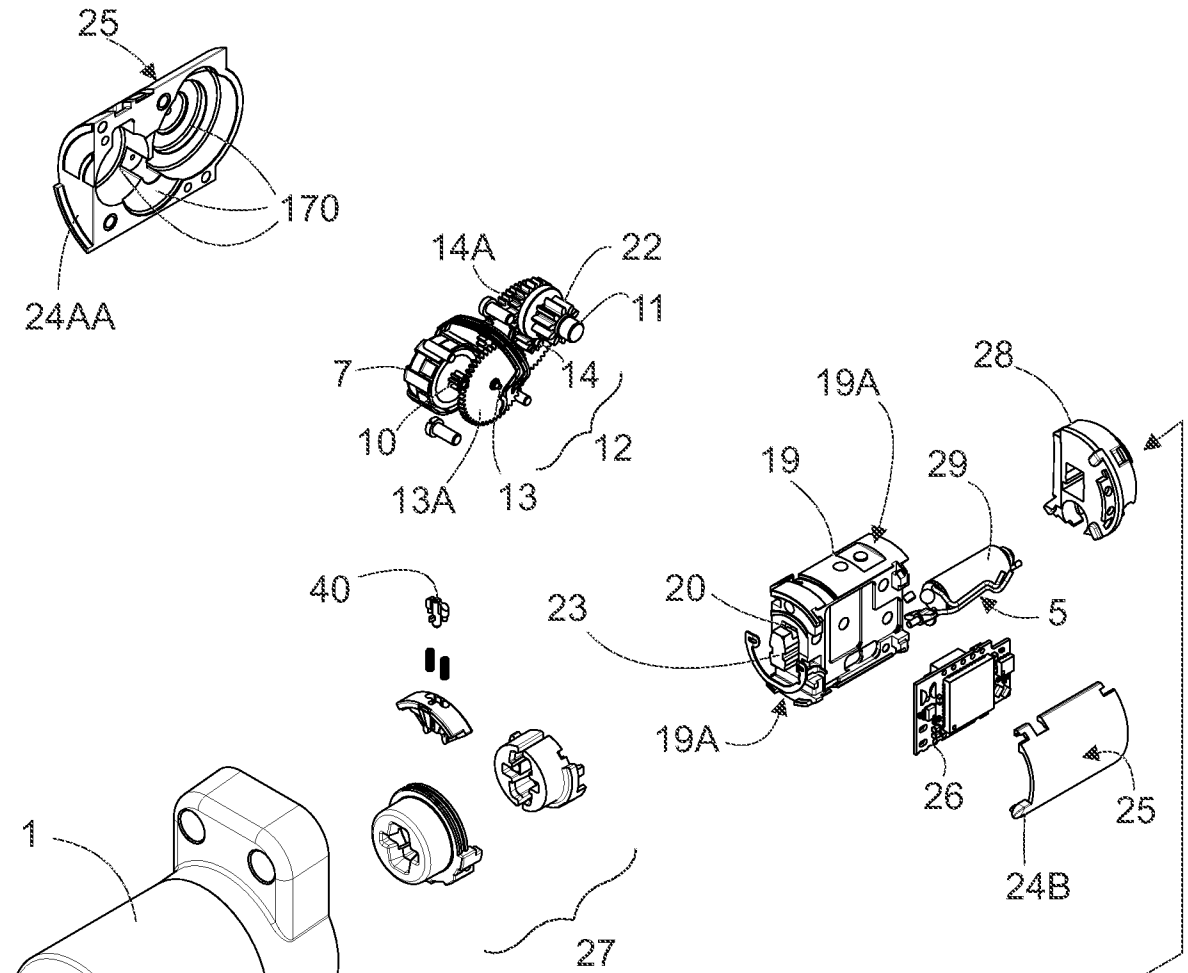
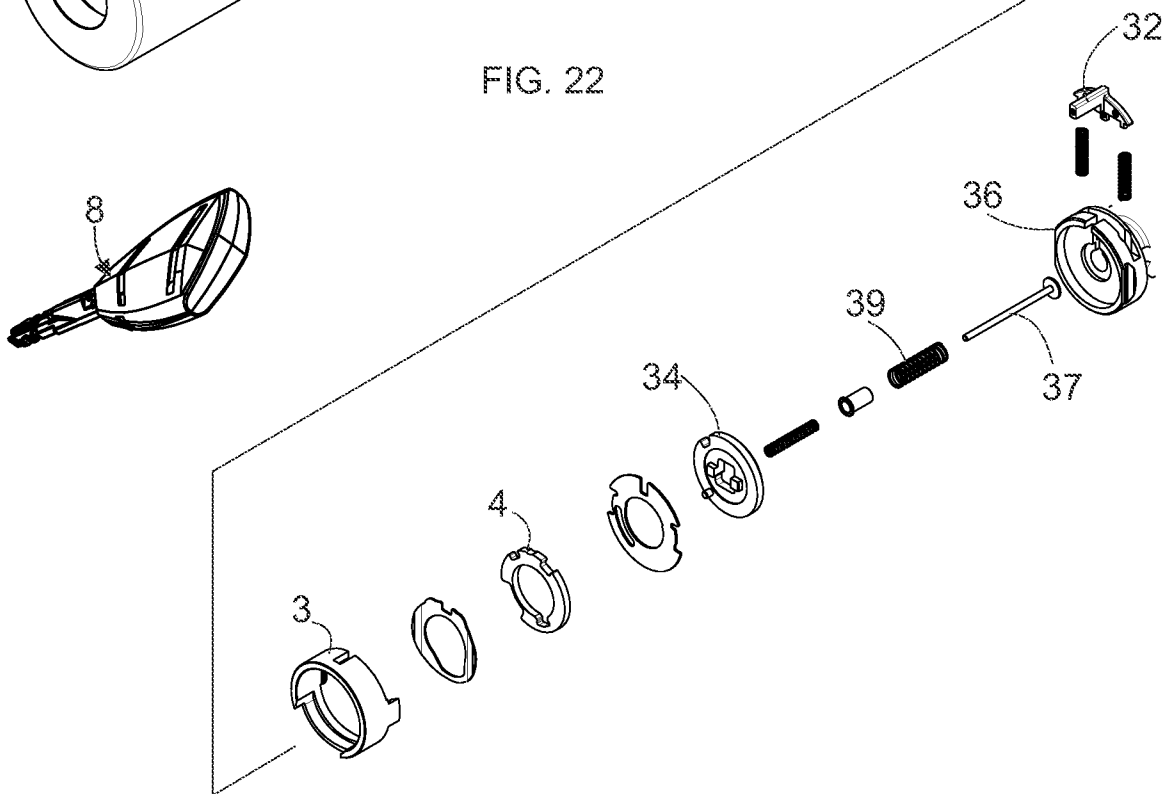

FIG. 22



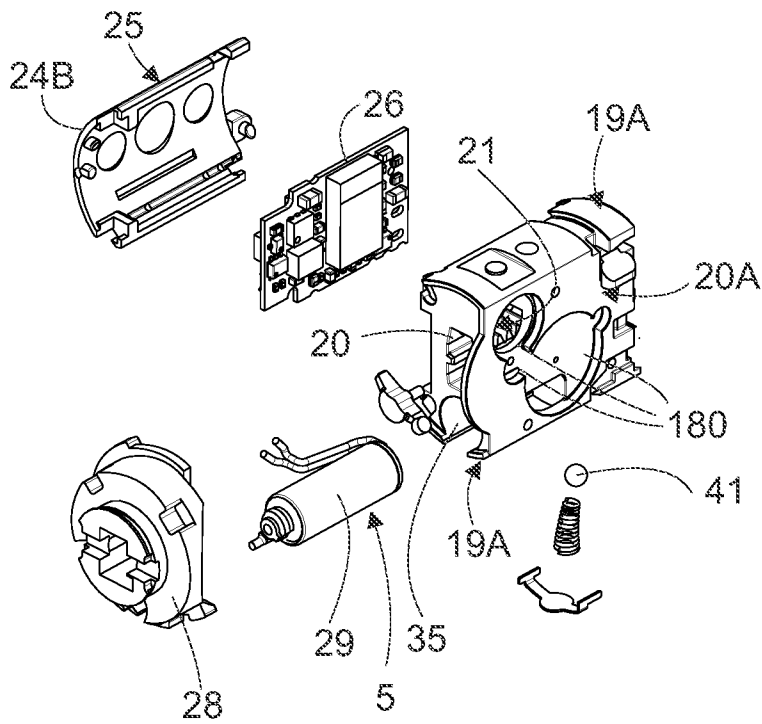

FIG. 23

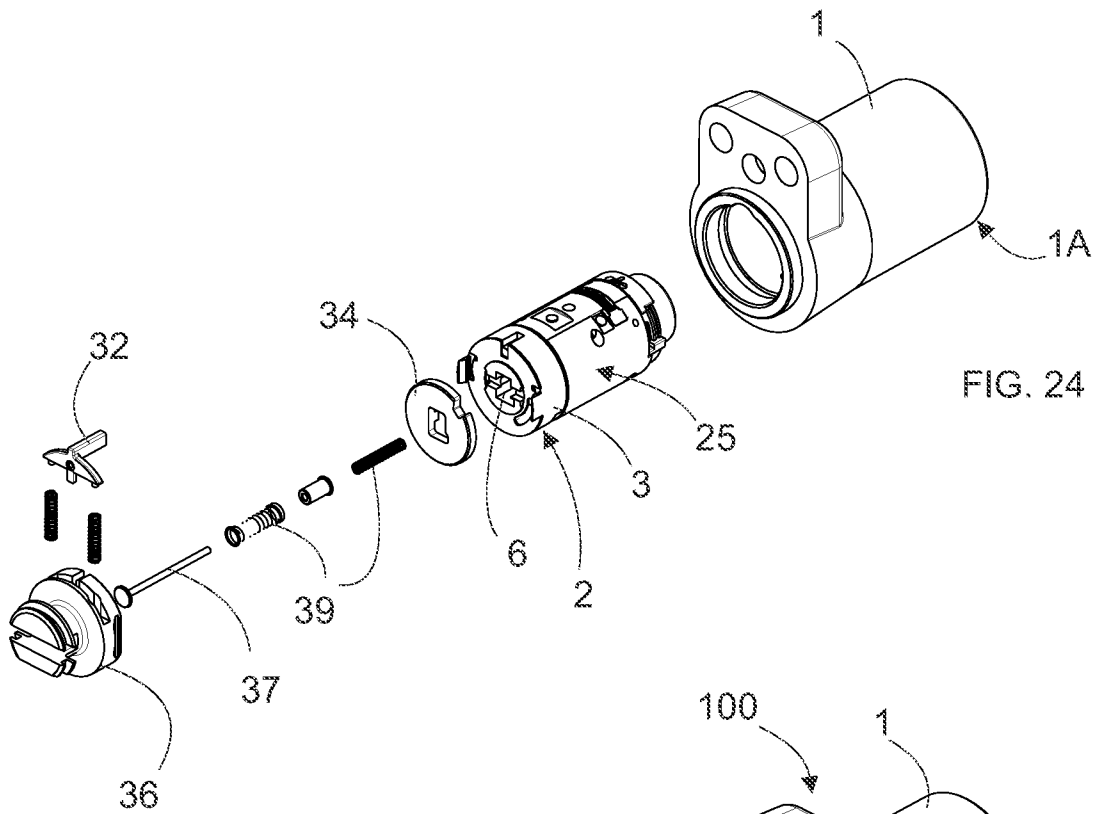

FIG. 24

FIG. 25

INTERNATIONAL SEARCH REPORT

International application No
PCT/FI2017/050239

A. CLASSIFICATION OF SUBJECT MATTER
INV. E05B47/06 G07C9/00
ADD.
According to International Patent Classification (IPC) or to both national classification and IPC

B. FIELDS SEARCHED
Minimum documentation searched (classification system followed by classification symbols)
E05B G07C

Documentation searched other than minimum documentation to the extent that such documents are included in the fields searched

Electronic data base consulted during the international search (name of data base and, where practicable, search terms used)
EPO-Internal, WPI Data

C. DOCUMENTS CONSIDERED TO BE RELEVANT

| Category* | Citation of document, with indication, where appropriate, of the relevant passages | Relevant to claim No. |
|-----------|--|-----------------------|
| A | WO 2006/008340 A1 (STONEKEY OY [FI]; PUKARI MIKA [FI]; KRUUSING ARVI [FI]) 26 January 2006 (2006-01-26) pages 1-9; figures 1-3 ----- | 1-44 |
| A | WO 99/18310 A1 (SILCA SPA [IT]; CHIES EZIO [IT]; FORNASARI PAOLO [IT]; PRADELLA GIOVAN) 15 April 1999 (1999-04-15) cited in the application pages 1-12; figures 1-6 ----- | 1-44 |
| A | US 5 265 452 A (DAWSON GERALD L [US] ET AL) 30 November 1993 (1993-11-30) the whole document ----- | 1-44 |

Further documents are listed in the continuation of Box C.

See patent family annex.

* Special categories of cited documents :

- "A" document defining the general state of the art which is not considered to be of particular relevance
- "E" earlier application or patent but published on or after the international filing date
- "L" document which may throw doubts on priority claim(s) or which is cited to establish the publication date of another citation or other special reason (as specified)
- "O" document referring to an oral disclosure, use, exhibition or other means
- "P" document published prior to the international filing date but later than the priority date claimed

- "T" later document published after the international filing date or priority date and not in conflict with the application but cited to understand the principle or theory underlying the invention
- "X" document of particular relevance; the claimed invention cannot be considered novel or cannot be considered to involve an inventive step when the document is taken alone
- "Y" document of particular relevance; the claimed invention cannot be considered to involve an inventive step when the document is combined with one or more other such documents, such combination being obvious to a person skilled in the art
- "&" document member of the same patent family

| | |
|---|--|
| Date of the actual completion of the international search 20 November 2017 | Date of mailing of the international search report 27/11/2017 |
|---|--|

| | |
|--|---|
| Name and mailing address of the ISA/ European Patent Office, P.B. 5818 Patentlaan 2 NL - 2280 HV Rijswijk Tel. (+31-70) 340-2040, Fax: (+31-70) 340-3016 | Authorized officer Boufidou, Maria |
|--|---|

INTERNATIONAL SEARCH REPORT

Information on patent family members

International application No

PCT/FI2017/050239

| Patent document cited in search report | Publication date | Patent family member(s) | Publication date |
|--|------------------|-------------------------|-----------------------------|
| WO 2006008340 | A1 | 26-01-2006 | AT 460548 T 15-03-2010 |
| | | | EP 1786998 A1 23-05-2007 |
| | | | FI 20041002 A 20-01-2006 |
| | | | WO 2006008340 A1 26-01-2006 |
| ----- | | | |
| WO 9918310 | A1 | 15-04-1999 | AT 255197 T 15-12-2003 |
| | | | AU 9440598 A 27-04-1999 |
| | | | DE 69820116 D1 08-01-2004 |
| | | | DE 69820116 T2 26-08-2004 |
| | | | EP 1042575 A1 11-10-2000 |
| | | | IT VE970043 A1 05-04-1999 |
| | | | US 6370928 B1 16-04-2002 |
| | | | WO 9918310 A1 15-04-1999 |
| ----- | | | |
| US 5265452 | A | 30-11-1993 | NONE |
| ----- | | | |