

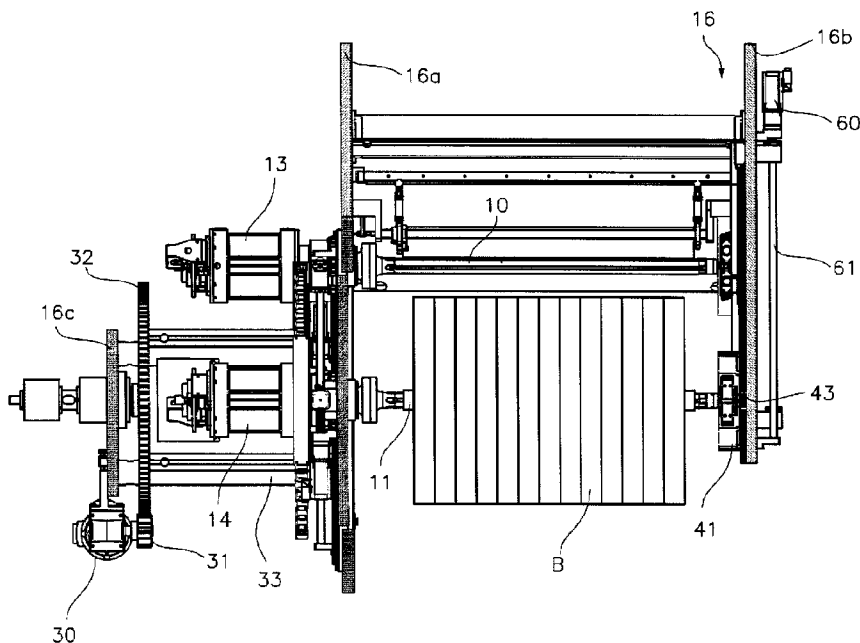

(86) Date de dépôt PCT/PCT Filing Date: 2012/05/24
(87) Date publication PCT/PCT Publication Date: 2012/12/06
(45) Date de délivrance/Issue Date: 2020/06/09
(85) Entrée phase nationale/National Entry: 2013/11/21
(86) N° demande PCT/PCT Application No.: ES 2012/000143
(87) N° publication PCT/PCT Publication No.: 2012/164115
(30) Priorité/Priority: 2011/06/01 (ES P201100614)

(51) Cl.Int./Int.Cl. *B65H 18/06* (2006.01),
B65H 18/10 (2006.01)
(72) Inventeurs/Inventors:
MIRAVETE GUERRERO, DAVID, ES;
PRAT GIL, JORDI, ES
(73) Propriétaire/Owner:
COMEXI GROUP INDUSTRIES, SAU, ES
(74) Agent: SMART & BIGGAR IP AGENCY CO.

(54) Titre : BOBINEUSE DE TYPE REVOLVER POUR MATERIAU EN BANDE
(54) Title: REVOLVER-TYPE WINDING MACHINE FOR STRIP MATERIAL



(57) **Abrégé/Abstract:**

The invention relates to a machine intended for plastic, laminated, aluminum, paper and self-adhesive materials. The machine includes two winding shafts (10, 11) which are each provided with a direct-drive motor (13, 14) and which are mounted on a plate (15) that can rotate with respect to a vertical wall (16a) of a mounting (16). The plate (15) has guides (50, 51) and actuation means for moving the motors (13, 14) and shafts (10, 11) linearly with respect to the plate (15). The second end of each winding shaft (10, 11) is supported by a carriage (40, 41) that can move in guides (44, 45) provided on a wall (16b), each carriage (40, 41) including a clamp (42, 43) that holds the ends of the winding shafts (10, 11) in a horizontal plane during the formation of a reel on any of said winding shafts (10, 11) and as the reel is moved into an unloading position.

ABSTRACT

The invention relates to a machine intended for plastic, laminated, aluminum, paper and self-adhesive materials. The machine includes two winding shafts (10, 11) which are
5 each provided with a direct-drive motor (13, 14) and which are mounted on a plate (15) that can rotate with respect to a vertical wall (16a) of a mounting (16). The plate (15) has guides (50, 51) and actuation means for moving the motors (13, 14) and shafts (10, 11) linearly with respect to the plate (15). The second end of each winding shaft (10, 11) is supported by
10 a carriage (40, 41) that can move in guides (44, 45) provided on a wall (16b), each carriage (40, 41) including a clamp (42, 43) that holds the ends of the winding shafts (10, 11) in a horizontal plane during the formation of a reel on any of said winding shafts (10, 11) and as the reel is moved into an unloading position.

REVOLVER-TYPE WINDING MACHINE FOR STRIP MATERIAL

Field of the invention

The present invention relates to a revolver-type winding machine (rotational winding
5 shaft-bearing turret structure) intended for plastic, laminated, aluminum, paper and self-
adhesive materials, prepared to operate at speeds in the order of 200 to 600 mpm (meters per
minute) and with web widths comprised between 520 and 2200 mm.

The winding machine of this invention comprises two parallel winding shafts with
independent direct-drive motors, where the reel progressively moves linearly during its
10 formation towards the center of a vertical support plate for supporting the assembly of
winding shafts and servomotors, and after formation of the reel, and with the reel located in
the center of said plate, the plate rotates and transfers an empty winding shaft to a material
receiving position, and the empty reel is subsequently removed by means of another linear
movement of the formed reel with respect to said disc-shaped plate.

15 Said motors for the direct drive of the winding shafts can be synchronous, i.e.,
servomotors, or asynchronous (alternating current) and equipped in said latter case with a
winding for direct drive, although such motors will generally be described hereinafter as
servomotors.

The machine has associated cutting means that allow sub-dividing the formed reel
20 into several units of the same or different widths.

Background of the Invention

The proposed machine has a general structure and corresponds to an operating
principle (independent linear movement of the two motor-winding shaft assemblies in
25 relation to a vertical disc-shaped plate that rotates about a horizontal axis and bearing said
assemblies) which is generally described in patents EP 243 748 (see Figures 7 and 8 and the
corresponding part in the description) and US 5 429 320.

With respect to this winding machine, the invention proposes alternative support
means, offering a releasable hold of the free ends of the winding shafts, which are retained at
30 all times, during the formation of the reel in said shafts until the reel is unloaded.

The invention also proposes a different structure of the rotary drive means for the disc-shaped plate entailing increased robustness of the machine and furthermore improving the conditions for supplying and distributing electric power and fluid to the different drive means of the machine, entailing simplification and greater reliability of said supply.

5 The invention further proposes means for the selective interlocking of the disc-shaped plate bearing the winding shafts during the movement of the reel being formed towards the central part of the plate, which assures movement of the reel being formed towards the center of the bearing disc-shaped plate in a horizontal plane.

10

Disclosure of the Invention

Accordingly, there is provided a revolver-type winding machine for web material which comprises: two parallel winding shafts each of which is provided with a first end directly connected to an independent rotary drive device and with a second end; a disc-shaped support plate bearing said winding shafts and corresponding rotary drive devices
15 perpendicularly to said disc-shaped support plate, said disc-shaped support plate being rotationally supported with respect to a circular opening of a first vertical wall of a framing; rotary drive means of said disc-shaped support plate to cause rotation about a horizontal axis centrally arranged with respect to the disc-shaped support plate to alternately arrange the
20 winding shafts in a loading position next to a web material supply source; guiding means and drive means for moving said rotary drive devices and winding shafts linearly along said disc-shaped support plate in a plane perpendicular thereto, and passing through a center of the disc-shaped support plate; support structures, supported on a second vertical wall of said framing opposite said first vertical wall, for supporting the second end of each of said
25 winding shafts during at least part of the linear movement of said winding shafts and during the formation of a reel on each of said winding shafts, said support structures comprising first and second carriages that are movable linearly by means of parallel first and second pairs of guides, characterized in that said first and second carriages bear selectively releasable holding elements comprising clamp means such that at all times the clamp means
30 keep the second ends of the winding shafts held in a horizontal plane coplanar with said

plane perpendicular to said disc-shaped support plate during the formation of a reel on any one of said winding shafts; said first and second pairs of guides and first and second carriages are located on the inner face of said second vertical wall of the framing, directly facing the second ends of the winding shafts; and the first carriage is arranged above one of said winding shafts and has a coupling section for coupling with the corresponding first pair of guides and an end section bearing the corresponding clamp, said end section being inclined downwards and projecting towards an outer side edge of the second vertical wall with respect to said coupling section, whereas the second carriage is arranged below the other of said winding shafts and has a coupling section for coupling with the corresponding second pair of guides and an end section bearing the corresponding clamp, said end section being inclined upwards and projecting towards said outer side edge of the second vertical wall with respect to said coupling section.

The winding shafts are thus held at the end opposite their direct drive end by means of a double flange clamp arrangement during the movement of the reel being formed towards a central position of the disc-shaped plate and during a subsequent linear movement with respect to said plate progressing towards an unloading position away from the center until the reel is resting on a lifting table, which will remove the formed reel from the winding shaft, which is then arranged in cantilever fashion. Said clamp arrangement opens, releasing the end of the shaft before removing the reel and at the time of rotation of the disc-shaped plate and turret where it releases the end of the empty winding shaft.

According to another feature of the invention, said pairs of guides and carriages are located on the inner face of said second wall of the framing directly facing the ends of the winding shafts.

Another particularity of the invention is the possibility it offers of selectively immobilizing the disc-shaped plate during linear movements of the reel being formed (and its drive servomotor) towards the central part of the disc-shaped plate, whereby assuring that

said movements are always made in a perfectly horizontal plane.

Means for supporting the weight of the formed reel in the center of the plate through said disc-shaped plate in the framing while the disc-shaped plate rotates, transferring an empty winding shaft to the loading position, whereby assuring that said movement does not generate over-efforts in means responsible for moving the drive servomotors of the winding shafts have also been provided.

These and other features of the invention will become clearer based on the following detailed description of an embodiment given by way of illustrative and non-limiting example with the aid of the attached drawings.

10

Brief Description of the Drawings

Figure 1 is a plan view of the winding machine of this invention, showing a reel B already formed on one of the winding shafts and occupying a central position with respect to a disc-shaped plate supporting the winding shafts.

Figure 2 is an elevational view of the inner face of one of the walls of the framing where the support and holding means for supporting and holding the ends of the winding shafts are located, one of the bearing carriages being shown in its end position by means of dotted lines.

Figure 3 is equivalent to the preceding figure but with the indication of a formed reel moving towards an unloading position.

Figure 4 is an enlarged partial elevational view of a sector of the framing where the ends of the winding shafts are supported and held.

Figure 5 is a perspective view of the section of the framing supporting the disc-shaped plate bearing the winding shafts and rotary drive servomotors.

Figure 6 is a partial perspective view of the rotational assembly supported in said part of the framing shown in Figure 5.

Figures 7 and 8 show an elevational view of the wall of the framing rotationally supporting the disc-shaped plate bearing the servomotors and the winding shafts.

Detailed Description of an Exemplary Embodiment

As can be seen in Figure 1, the proposed revolver-type winding machine for web material comprises two parallel winding shafts 10, 11 each of which is provided with an independent rotary drive servomotor 13, 14 connected directly to a first end of the corresponding winding shaft 10, 11. Said drive servomotors 13, 14 and winding shafts 10, 11, are associated with a disc-shaped support plate 15 with respect to which said winding shafts 10, 11 are arranged in a perpendicular manner. The disc-shaped plate 15 is rotationally supported with respect to a circular opening 17 of a vertical wall 16a of a framing 16, and said disc-shaped plate 15 has associated rotary drive means, which will be described below, to cause rotation about a horizontal axis centrally arranged with respect to the plate 15 for the purpose of alternately arranging the winding shafts 10, 11 in a loading position next to the web material supply source.

According to the structure disclosed in aforementioned EP 243748, the disc-shaped plate 15 has associated guiding means 50, 51 (common to the two servomotors 13 and 14) and drive means 52, 53, 54, 55 (linear pneumatic actuator and guide in both cases) for moving said rotary drive servomotors 13, 14 and winding shafts 10, 11 linearly along the support plate 15 in a plane perpendicular to same, passing through its center, i.e., diametrical, such that the reel being formed progressively advances towards the center of said disc-shaped plate 15, and when the disc-shaped plate 15 rotates 180° to arrange the empty winding shaft in the loading position, the reel is supported in the center of the plate 15, avoiding any lifting effort.

As for the second end of each of said winding shafts 10, 11, according to the present invention there is provided a support structure for supporting the shafts 10, 11 during the linear movement thereof and during the formation of a reel on each of said shafts, said support structure being arranged associated with a second vertical wall 16b of the framing that is parallel to and opposite the vertical wall 16a of the framing. This support structure (one for each winding shaft) comprises a carriage 40, 41 that can move linearly by means of parallel pairs of guides 44, 45, each carriage 40, 41 bearing selectively releasable holding elements equipped with clamp devices 42, 43 such that at all times said clamps keep the ends of the winding shafts 10, 11 held in a horizontal plane coplanar with said plane

- 6 -

perpendicular to said plate 15 during the formation of a reel on any one of said winding shafts 10, 11. Each of said clamp devices 42, 43 is provided with an autonomous drive actuator (pneumatic piston or cylinder) 46.

As previously indicated, the pairs of guides 44, 45 and carriages 40, 41 being located
5 on the inner face of the wall 16b of the framing 16 directly facing the ends of the winding shafts 10, 11 is also characteristic of the proposal of this invention. Such arrangement of the support-holding means for supporting-holding the ends of the shafts assures the parallelism of the winding shafts 10, 11 and the correct holding thereof at all times during the operating cycle of the winding machine. Said holding is compatible with the rotation of the shaft, for
10 which purpose the clamp means have been provided with rolling coupling means for the coupling with the end of each shaft 10, 11. Furthermore the fact that each of the winding shafts 10, 11 is always held at its two ends allows assuring perfect alignment of said shafts perpendicular to the disc-shaped plate 15.

As can be seen in Figures 2 to 4, one of the carriages 40 and its clamp device 42 are
15 arranged above the winding shaft 10, whereas the second carriage 41 and its clamp device 43 are arranged below the second winding shaft 11, so there cannot be any interference at any time between the carriages and holding means during the linear movements thereof along the pairs of guides 44, 45.

The carriages 40, 41 are driven by systems of linear actuators and guides 60, 61, 62,
20 63 located on the outer face of said vertical wall 16b.

Each of the carriages 40, 41 has (see Figures 2 and 3) an end section 40a, 41a bearing the clamp device 42, 43, inclined upwards and projecting towards the outer side of the wall 16b with respect to a coupling section for coupling with the pairs of guides 44, 45, such that
25 at the end of the linear travel of the reel towards one of the sides (see Figure 2, zone shown with a dotted line), the reel is arranged in a zone from which it can be extracted by conventional means (for example by means of a lifting platform) and removed without the wall 16b being an obstacle.

As can be seen in Figures 5 and 6, said disc-shaped plate 15 bearing the servomotors 13, 14 and winding shafts 10, 11 is inserted partially in said circular opening 17 of the wall
30 16a of the framing 16 and rotationally supported on rolling elements 18 arranged along the

periphery of said opening 17.

Figure 6 shows the rotational turret structure supported between the walls 16a and 16b of the framing 16 and consisting of the disc-shaped plate 15 supported by the rolling elements 18 and which is integral by means of struts 33 with a gear wheel 32 rotationally supported (with the appropriate bearings) in a vertical wall 16c of the framing, parallel to the preceding walls 16a and 16b. Said gear wheel is in turn coupled to a gear of a transmission 31 driven by a geared motor 30, also supported on the wall 16c.

Figures 6 and 7 show that the disc-shaped plate 15 includes elements 70 (for example a bridge part) at two diametrically opposed points of its periphery, and in the vertical wall 16a there are means 71 (driven by e.g. pneumatic actuators) that can be coupled with said elements 70, immobilizing the disc-shaped plate 15 in a very precise position suitable for effectively assuring the movement of the winding shafts in a horizontal plane.

When the disc-shaped plate rotates, the finished reel B on one of the winding shafts 10, 11 is arranged at the center of rotation of said disc-shaped plate 15 and turret or rotating assembly, held on the side opposite the drive by one of the clamp devices 42, 43. The other winding shaft 10, 11 is arranged at one end in its rewinding entry position and it rotates 180°, being arranged in cantilever fashion. Once said 180° rotation is made, the carriage with the open clamp devices 42, 43 moves to said empty shaft 10, 11, the clamp device 42, 43 closing to initiate winding and linear movement during the formation of the reel.

Figures 7 and 8 show the guide elements 50, 51 and drive elements 52, 53, 54, 55 (linear pneumatic actuator and guide in each case) for moving the rotary drive servomotors 13, 14 and winding shafts 10, 11 linearly. Said servomotors 13, 14 are arranged on carriages 56, 57 bearing the elements.

Figure 8 shows a locking device 59 for locking one of said carriages 56, 57 while the disc-shaped plate rotates to move one of the winding shafts 10, 11 to a loading position as explained above, preventing the drive system for said carriage 56, 57 from having to withstand the weight of the reel in said conditions.

In the exemplified embodiment, said locking device 59 comprises a pneumatic actuator operating a pin that can be inserted in a cavity of the body of one of the carriages 56, 57.

- 8 -

The power supply and the pneumatic supply to the elements of the winding machine being described extends through the wall 16c of the framing 16 and the gear wheel 32 which has a central opening for such purpose, the struts 33 being useful as support elements for parts controlling and distributing power or compressed air (for example those installed in
5 small cabinets).

The invention can be implemented using different devices which a person skilled in the art will consider as being equivalent for performing the exemplified functions.

**THE EMBODIMENTS OF THE INVENTION IN WHICH AN EXCLUSIVE
PROPERTY OR PRIVILEGE IS CLAIMED ARE DEFINED AS FOLLOWS:**

1. A revolver-type winding machine for web material which comprises:
 - 5 two parallel winding shafts (10, 11) each of which is provided with a first end directly connected to an independent rotary drive device (13, 14) and with a second end;
 - a disc-shaped support plate (15) bearing said winding shafts (10, 11) and corresponding rotary drive devices (13, 14) perpendicularly to said disc-shaped support plate (15), said disc-shaped support plate (15) being rotationally supported with respect to a circular
10 opening (17) of a first vertical wall (16a) of a framing (16);
 - rotary drive means of said disc-shaped support plate (15) to cause rotation about a horizontal axis centrally arranged with respect to the disc-shaped support plate (15) to alternately arrange the winding shafts (10, 11) in a loading position next to a web material supply source;
 - 15 guiding means (50, 51) and drive means (52, 53, 54, 55) for moving said rotary drive devices (13, 14) and winding shafts (10, 11) linearly along said disc-shaped support plate (15) in a plane perpendicular thereto, and passing through a center of the disc-shaped support plate (15);
 - support structures, supported on a second vertical wall (16b) of said framing opposite
20 said first vertical wall (16a), for supporting the second end of each of said winding shafts (10,11) during at least part of the linear movement of said winding shafts (10, 11) and during the formation of a reel on each of said winding shafts (10,11), said support structures comprising first and second carriages (40, 41) that are movable linearly by means of parallel first and second pairs of guides (44, 45),
 - 25 characterized in that
 - said first and second carriages (40, 41) bear selectively releasable holding elements comprising clamp means (42, 43) such that at all times the clamp means (42, 43) keep the second ends of the winding shafts (10, 11) held in a horizontal plane coplanar with said plane perpendicular to said disc-shaped support plate (15) during the formation of a reel on any one
30 of said winding shafts (10, 11);

said first and second pairs of guides (44, 45) and first and second carriages (40, 41) are located on the inner face of said second vertical wall (16b) of the framing (16), directly facing the second ends of the winding shafts (10, 11); and

5 the first carriage (40) is arranged above one of said winding shafts (10, 11) and has a coupling section for coupling with the corresponding first pair of guides (44) and an end section (40a) bearing the corresponding clamp (42), said end section (40a) being inclined downwards and projecting towards an outer side edge of the second vertical wall (16b) with respect to said coupling section, whereas the second carriage (41) is arranged below the other of said winding shafts (10, 11) and has a coupling section for coupling with the corresponding
10 second pair of guides (45) and an end section (41a) bearing the corresponding clamp (43), said end section (41a) being inclined upwards and projecting towards said outer side edge of the second vertical wall (16b) with respect to said coupling section.

2. The winding machine according to claim 1, characterized in that the first and second
15 carriages (40, 41) are driven by systems of linear actuators and guides (60, 61, 62, 63) located on the outer face of said second vertical wall (16b).

3. The winding machine according to claim 1, characterized in that each of the clamps
20 (42, 43) has autonomous pneumatic drive means (46).

4. The winding machine according to claim 1, characterized in that the disc-shaped
plate (15) is inserted partially in said circular opening (17) of the first vertical wall (16a) of the framing (16) and rotationally supported on rolling elements (18) arranged along the periphery
25 of said opening (17).

5. The winding machine according to claim 1, characterized in that the disc-shaped
support plate (15) is integral by means of struts (33) with a gear wheel (32) rotationally
supported on a third vertical wall (16c) of the framing, parallel to the first and second vertical
walls (16a and 16b), and said gear wheel is coupled to a gear of a transmission (31) driven by
30 a geared motor (30).

6. The winding machine according to claim 4, characterized in that the disc-shaped support plate (15) has elements (70) at two diametrically opposed points of the periphery of the disc-shaped support plate (15), and in the first vertical wall (16a) of the framing (16) there are means (71) coupleable with said elements (70), immobilizing the disc-shaped support plate (15) in a position suitable for the movement of the winding shafts in a horizontal plane.

7. The winding machine according to claim 1, characterized in that said drive means for linearly moving said rotary drive devices (13, 14) and winding shafts (10, 11) comprise third and fourth carriages (56, 57) bearing the rotary drive devices (13, 14) and winding shafts (10, 11) and movable in said guiding means (50, 51), said third and fourth carriages (56, 57) being driven by pneumatic linear actuators (53, 55) over guides (52, 54).

8. The winding machine according to claim 7, characterized in that locking means (59) lock at least one of said third and fourth carriages (56, 57) while the disc-shaped support plate (15) rotates to move one of the winding shafts (10, 11) to said loading position with the formed reel in a central position.

9. The winding machine according to claim 8, characterized in that said locking means (59) comprise a pin insertable into a cavity of one of the third and fourth carriages (56, 57).

10. The winding machine according to claim 1, characterized in that a power supply and a pneumatic supply to the elements of the machine extends through the third vertical wall (16c) of the framing and a gear wheel (32), which has a central opening, said gear wheel (32) and the disc-shaped support plate (15) being integrated through struts (33) which are support elements for parts distributing one of power and compressed air.

11. The winding machine according to claim 1, characterized in that said rotary drive devices (13, 14) of the winding shafts (11, 12) comprise one of a servomotor and an

alternating current asynchronous motor with an associated winding for the direct drive of the winding shaft (11, 12).

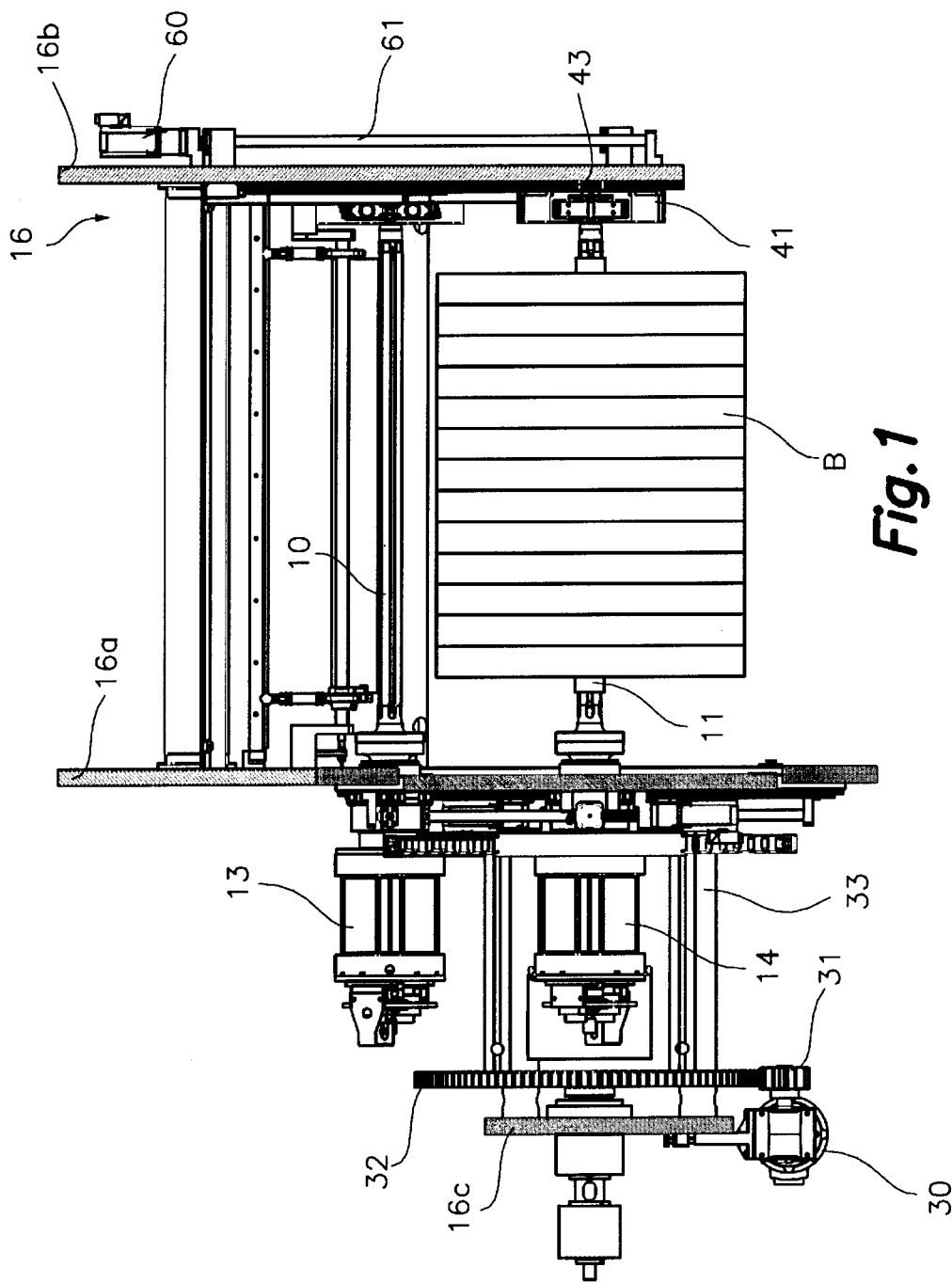

Fig. 1

2/7

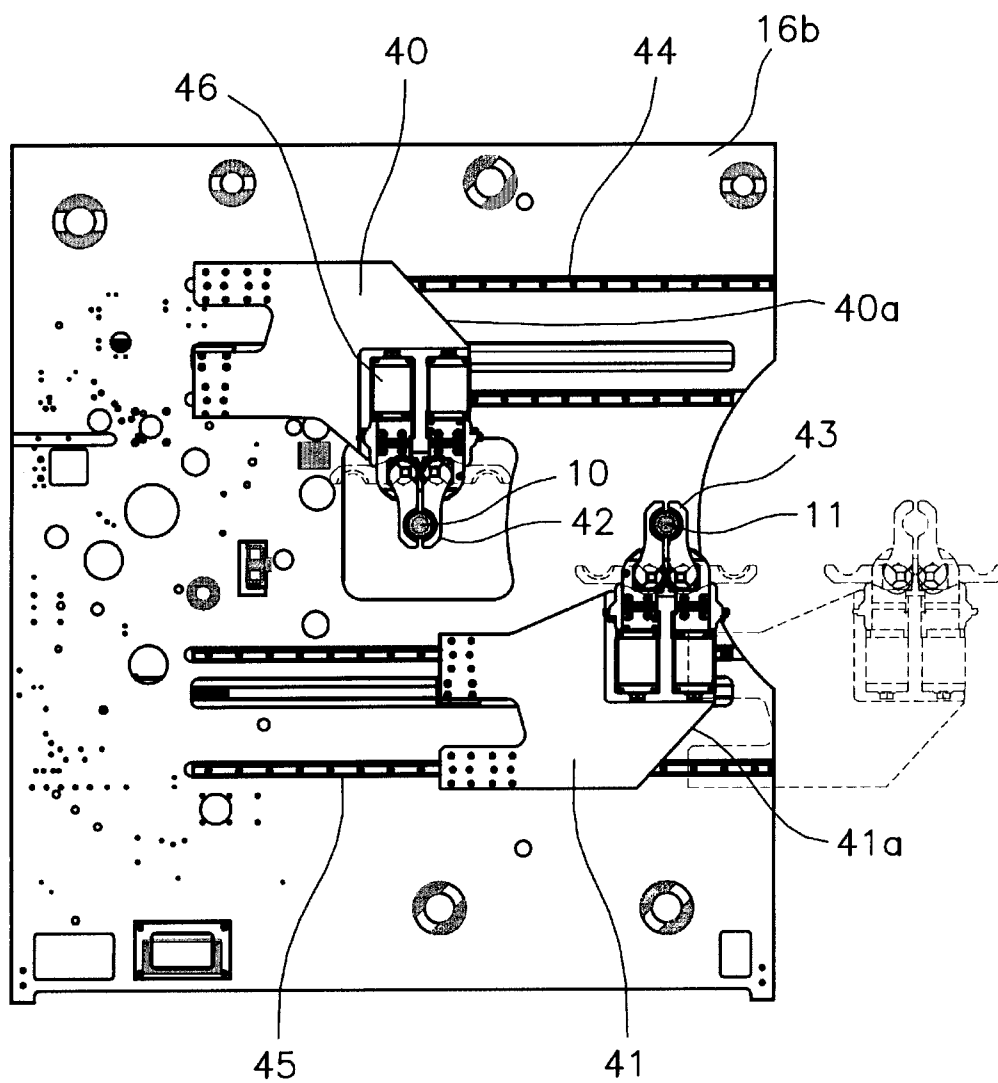

Fig.2

3/7

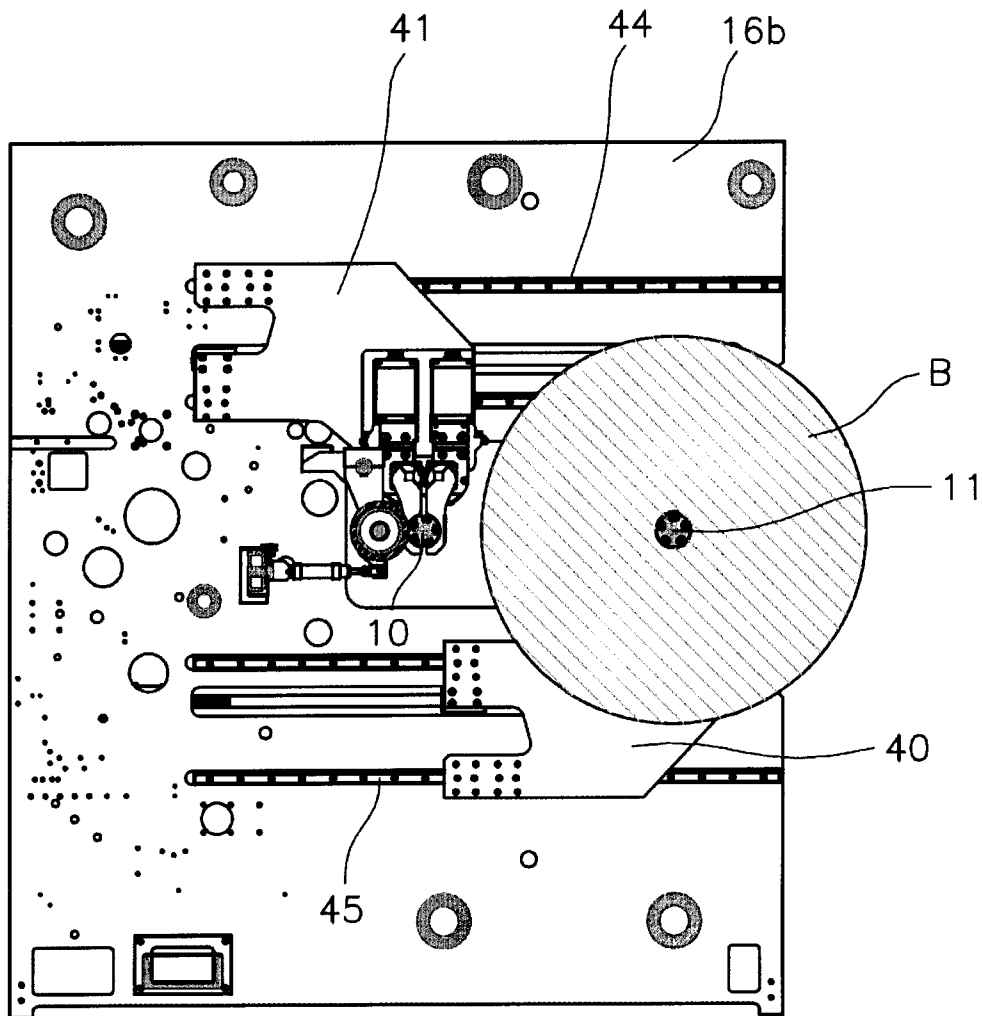

Fig.3

4/7

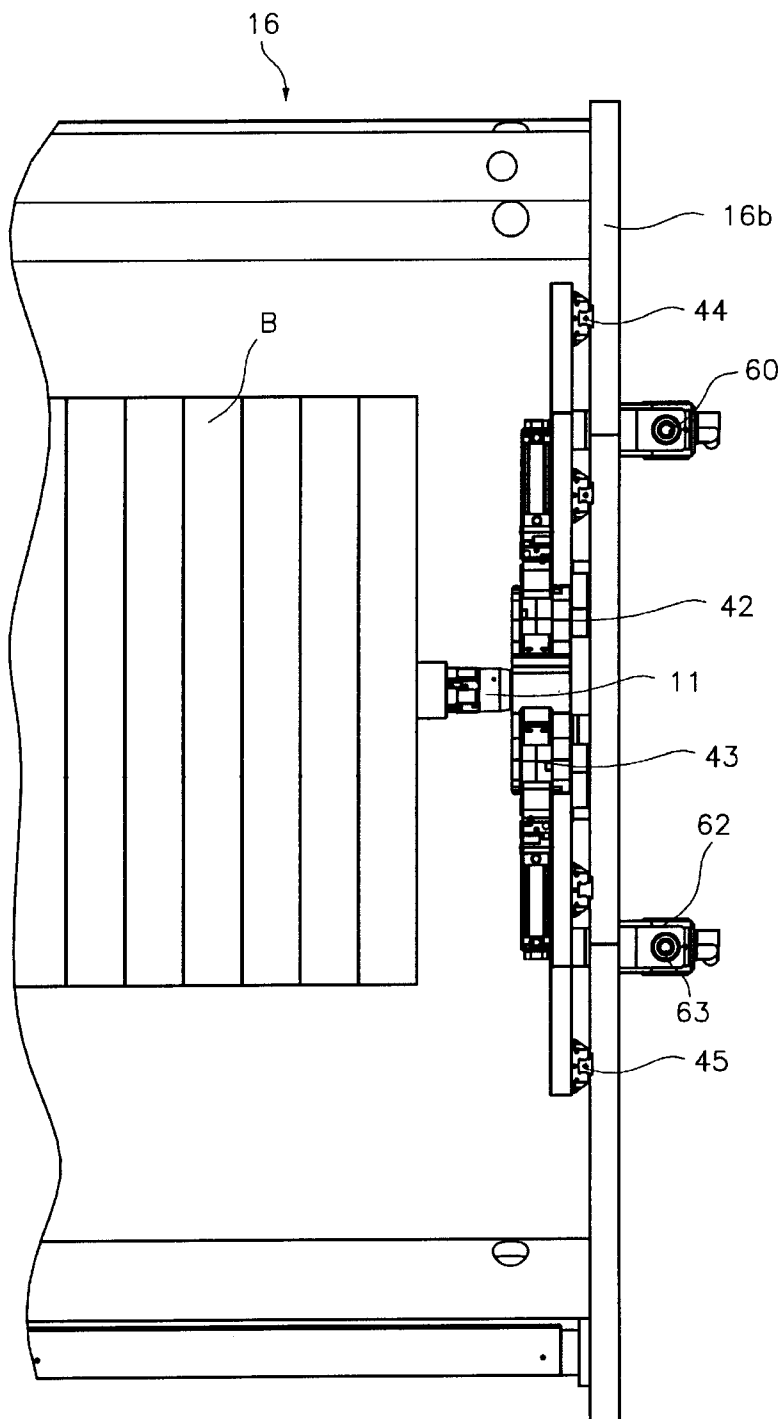

Fig. 4

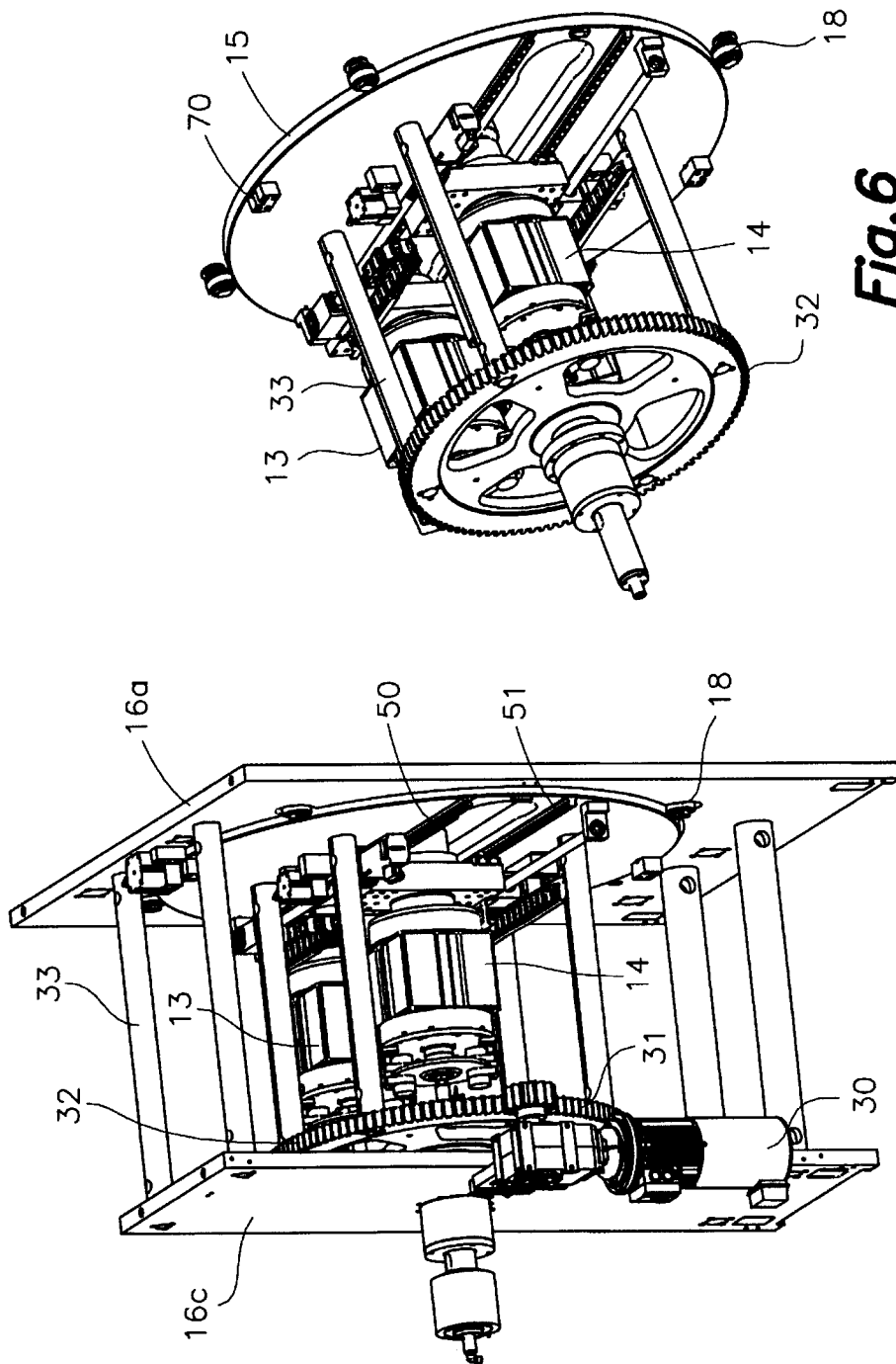

Fig. 6

Fig. 5

6/7

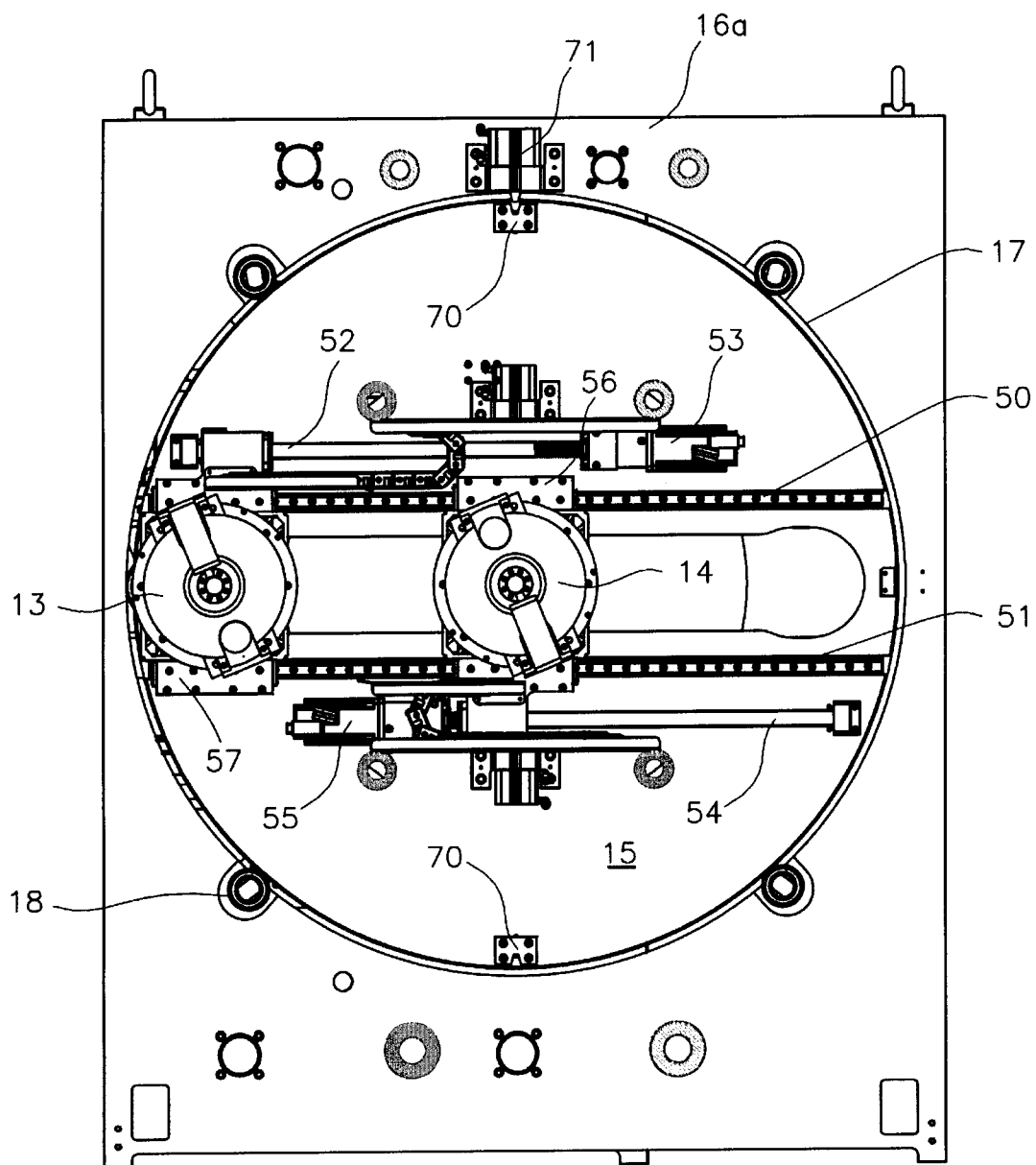

Fig. 7

7/7

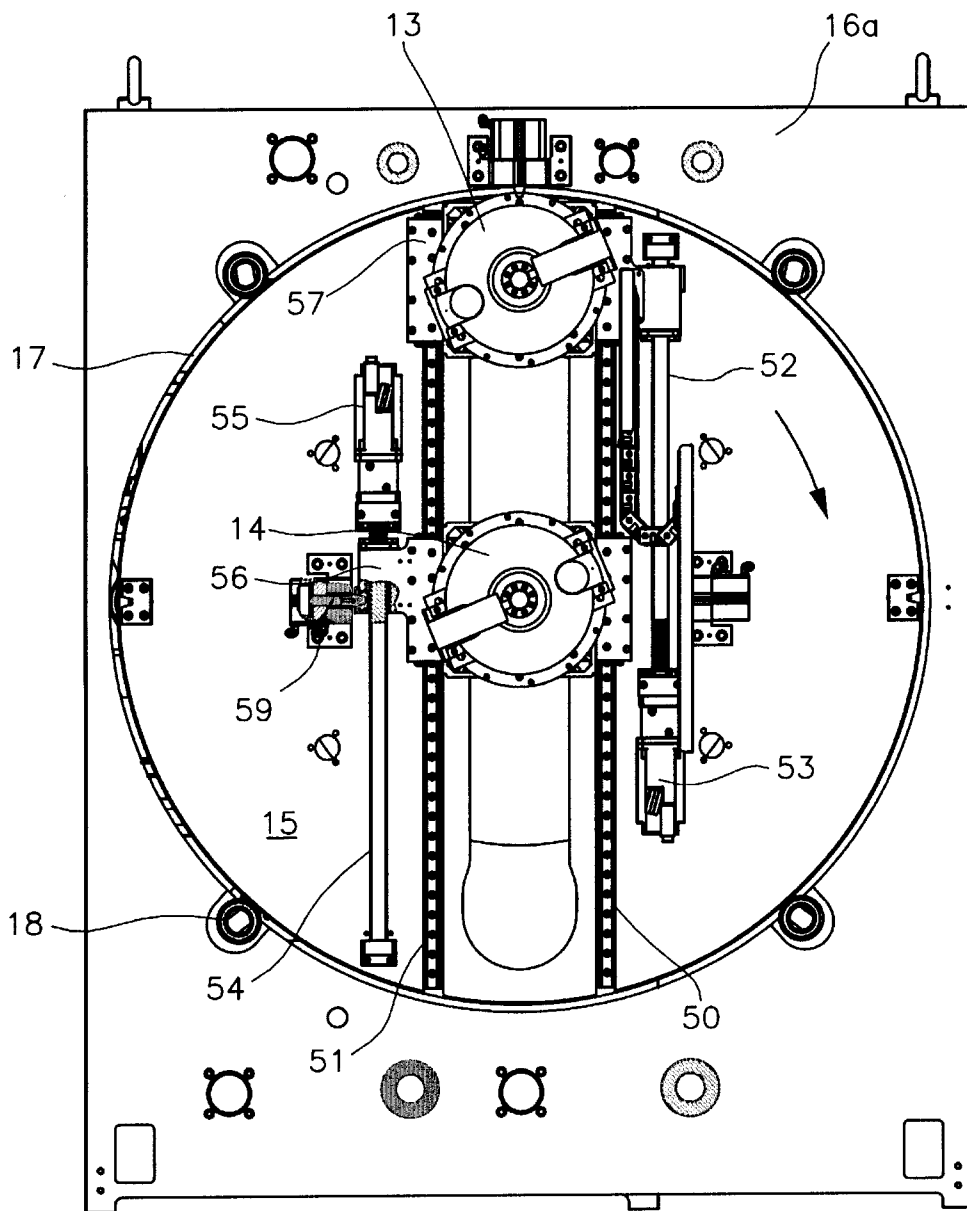

Fig. 8

