

12

**EUROPEAN PATENT APPLICATION**

21 Application number: **85302266.3**

51 Int. Cl.<sup>4</sup>: **A 45 D 4/10**

22 Date of filing: **01.04.85**

43 Date of publication of application:  
**15.10.86 Bulletin 86/42**

84 Designated Contracting States:  
**AT BE CH DE FR GB IT LI LU NL SE**

71 Applicant: **Caruso, Richard**  
**7801 Montgomery Avenue**  
**Elkins Park Pennsylvania(US)**

72 Inventor: **Caruso, Richard**  
**7801 Montgomery Avenue**  
**Elkins Park Pennsylvania(US)**

74 Representative: **Thomson, Roger Bruce et al,**  
**POLLAK MERCER & TENCH High Holborn House 52-54**  
**High Holborn**  
**London WC1V 6RY(GB)**

54 **Steamable hair curler.**

57 A hair curler (10) includes a porous sleeve (24) of foam plastics material surrounded by a perforated sleeve (26) which is of more rigid material. The foam sleeve (24) is closed at one end and open at the other end for receiving steam, via hole (20) in end cap (18). The foam sleeve may be used with or without a core (12). A shield (32) is optionally provided.

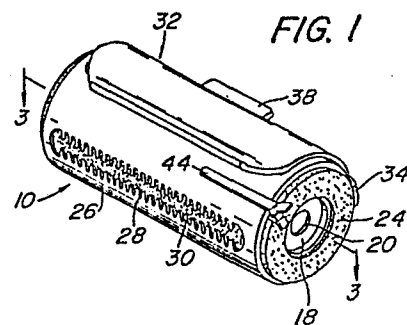

-1-

STEAMABLE HAIR CURLERBackground

Hair curlers adapted to be steamed before they are applied to hair are known. The present invention is directed to solving several problems associated with known hair curlers by reducing the number of components, rendering the components more flexible for ease of deformation to partially conform to the shape of a person's head, reducing the cost of manufacture of said hair curlers, etc.

Summary Of The Invention

The present invention in one embodiment is directed to a hair curler which includes a first coreless sleeve of flexible foam polymeric material closed at one end. A second more rigid sleeve surrounds the first sleeve. The second sleeve has spaced longitudinal slots on its periphery to render the central portion of the second sleeve more flexible. The other end of the first sleeve is open for receiving steam.

The hair curler preferably has the following additional features. Teeth are provided along the periphery of the slots in the second sleeve so that they may catch hair and retain the hair curler in place. A shield may be provided for removable attachment to the ends of the hair curler. The sleeve may be provided with a core which is removable whereby the first and second sleeves may be used with or without the core.

1 Various objects and advantages of the invention will  
be set forth hereinafter.

For the purpose of illustrating the invention, there  
is shown in the drawings a form which is presently preferred;  
5 it should be understood, however, that this invention is not  
limited to the precise arrangements shown.

In the drawings:

Figure 1 is a perspective view of a hair curler in  
accordance with one embodiment of the present invention.

10 Figure 2 is an exploded view of the components of  
the hair curler shown in figure 1.

Figure 3 is a sectional view taken along the line 3-3  
in figure 1.

15 Figure 4 is a sectional view taken along the line 4-4  
in figure 3.

Figure 5 is an exploded view of an alternative core.

Figure 6 is an exploded view of one end of a core.

Figure 7 is a sectional view of another embodiment  
of the present invention.

20 Figure 8 is a perspective view of another embodiment  
of the present invention.

Figure 9 is a sectional view taken along the line 9-9  
in figure 8.

Figure 10 is a sectional view of another embodiment.

25 Figure 11 is a sectional view of another embodiment.

Figure 12 is a plan view of a sleeve.

Figure 13 and 14 are perspective views of another  
embodiment.

#### Detailed Description

30 Referring to the drawings in detail, wherein like  
numerals indicate like elements, there is shown in figure 1  
a perspective view of a hair curler in accordance with the  
present invention designated generally as 10. As shown more  
clearly in figure 2, the hair curler 10 includes an elongated  
35 gated core 12 which may be made from a heat conducting  
metal such as aluminum or from a polymer plastic material.  
The core 12 has longitudinally extending perforations or

1 slots 14. Core 12 is provided with a closed end 16 having  
a handle 15. See figure 3. At its other end, core 12 is  
provided with a removable end cap 18. End cap 18 is adap-  
5 portion 22 at the end of the core 12 remote from the  
closed end 16. End cap 18 is provided with a hole 20  
coaxial with the core 12. Ease of manufacture is facil-  
itated by making end cap 18 separate from the core.

The core 12 is surrounded by a first sleeve 24 of  
10 porous material with a slight force fit therebetween.  
Sleeve 24 is preferably a foam polymeric plastic material  
whose radial thickness is substantially greater than the  
radial thickness of the core 12 and whose length corres-  
ponds with the length of core 12. The sleeve 24 is  
15 surrounded by second sleeve 26 with a slight force fit  
therebetween. Sleeve 26 is preferably made from a poly-  
meric material impervious to liquids and is slightly  
shorter than sleeve 24 whereby sleeve 26 is not likely to  
touch a person's ear.

20 The sleeve 26 may have a length corresponding to the  
length of sleeve 24 and is substantially thinner than  
sleeve 24. Sleeve 26 has a plurality of holes or longi-  
tudinally extending slots 28 in its central portion.  
The slots 28 render the central portion of the sleeve 26  
25 very flexible so that it may be readily deformed by minimal  
finger pressure to facilitate catching hair. The side  
edges of the slots 28 are preferably provided with a plur-  
ality of arcuately disposed fingers or teeth 30 which are  
adapted to catch hair when the hair curler is wound around  
30 hair. Teeth 30 catch hair and comb it. The number of  
slots 28 is variable. By way of example, a sleeve 26  
having a diameter of approximately 1 1/4 inches (31 mm), I  
prefer to provide at least four slots 28 with the gap  
between oppositely disposed teeth 30 being approximately  
35 1/4 inch (6.4 mm) and the length of the teeth being approxi-  
mately 3/16 inch (5 mm). Those dimensions will change on  
different size rollers.

1           A shield 32 is optionally provided and facilitates  
handling of the steamed curler and/or retaining hair around  
the curler. The shield 32 is generally C-shaped as shown  
more clearly in figures 2 and 4. Shield 32 is provided  
5 with tabs 34 and 35 at its ends adjacent the bight. A  
radially outwardly directed handle 38 is attached to the  
bight on the shield 32. See figure 4. The inner surface  
of the tabs 34, 35 are provided with notches 36 to facilitate  
attaching the shield 32 to opposite ends of the sleeve 26.  
10 Shield 32 is slightly shorter than sleeve 26 so that the  
tabs 34, 35 are under tension. The notches 36 facilitate  
adjustment of the gap 40 between the inner periphery of  
shield 32 and the outer periphery of sleeve 26. See figures  
3 and 4. Shield 32 reduces the rapidity of heat loss  
15 whereby the curler stays warm for a longer period of time.

          Steam may be introduced into the interior of core 12  
by way of hole 20 in a conventional manner. If the shield  
32 is utilized to support the hair curler during steaming,  
it is removed. Thereafter, the steamed roller is wound  
20 around hair. Thereafter, either a hair clip 44 and/or  
the shield 32 is applied to hold the hair around the roller  
in the gap 40. The flexibility of the tabs 34, 35 and the  
notches 36 facilitate adjustment of the gap 40 to accommo-  
date the amount of hair wound around the roller.

25           The flexibility of the sleeve 26 imparted by the  
longitudinal slots 28 facilitates deformation of the  
central portion of the hair roller to approximate the  
curvature of the person's head. Thus, the hair curler  
10 is more comfortable to a wearer since the central  
30 portion of the roller is flexible and self-accommodating  
to the arcuate curvature of a person's head which varies  
at different locations around the person's head. In  
addition, hair curler 10 may be utilized in connection  
with long hair where flexibility of the hair curler is not  
35 essential. The core 12 is totally removable before or  
after the hair curler 10 is wound around a person's hair.

1 Removal of the core 12 further increases the flexibility  
of the hair curler 10.

In figure 5, there is illustrated another embodiment  
of the core which is designated 12'. The core 12' is iden-  
5 tical with core 12 except as will be explained herein. The  
length of the slots 14' in core 12' is greater than the length  
of the slots 14. Thus, the slots 14' extend through the re-  
duced diameter portion 22'. This feature is a manufacturing  
expedient which facilitates ease of making the core 12' and  
10 facilitates ease with which the end cap 18 may be telescoped  
over the reduced diameter 22'.

If the particular circumstances indicate that it would  
be desirable not to utilize the shield 32 for retaining hair  
on the hair curler, hair clip 44 may be utilized to embrace  
15 a portion of hair and extend along the inner and outer sur-  
faces of the sleeve 26. See figure 1.

In figure 7 there is illustrated a cross sectional  
view of another embodiment of the present invention wherein  
the hair curler is designated generally as 50. Hair curler  
20 50 is identical with the hair curler 10 except as will be  
explained herein. Hair curler 50 is coreless and includes  
a first flexible foam sleeve 52 corresponding to sleeve 24  
which is surrounded by sleeve 54 corresponding to sleeve  
26. A shield 56 which corresponds to shield 32 is attached  
25 to the ends of sleeve 52 by end tabs as described above.  
One end of the sleeve 52 is closed in any convenient manner.  
A simple and inexpensive manner for closing one end of the  
sleeve 52 is by way of an end cap 56' having a short boss 58  
telescoped into the sleeve 52 as shown at the left hand end  
30 of figure 7. Alternatively, cap 56' could be cup shaped and  
telescoped over the outer periphery of one end of sleeve  
52. If desired, the open end of the sleeve 52 may be  
provided with a removable end cap 60 having a hole 62  
coaxial with the inner periphery of the sleeve 52. Curler  
35 50 is utilized in the same manner as described above.

1           The hair curler 50 is lighter in weight and cheaper  
to manufacture than the hair curler 10. In addition, the  
lack of a core renders the hair curler 10 more flexible  
and comfortable. Excluding the shield, hair curler 10 has  
5 a weight of approximately 15 grams whereas hair curler 50  
without the shield may have a weight of 7 to 8 grams.

In figure 8, there is illustrated another embodiment  
of the present invention wherein the hair curler is desig-  
nated generally as 70. The hair curler 70 is identical  
10 with the hair curler 10, except as follows. A sleeve 72  
is telescoped over the sleeve 26 and has a length corres-  
ponding to the length of sleeve 26. Sleeve 72 is preferably  
a layer of foam polymer plastic material corresponding to  
the material of sleeve 24. Sleeve 72 is preferably thinner  
15 than the radial thickness of the sleeve 24. The relative  
thickness of sleeves 24 and 72 may be different as desired.  
The provision of the sleeve 72 renders the curler 70 with  
longer heat retention than hair curler 10 while permitting  
wrapping hair therearound without feeling the higher temp-  
20 erature within the roller. In addition, sleeve 72 spaces  
the hair to be curled from the sleeve 26 so as to prevent  
the application of moisture which may condense on sleeve  
26 when the steam is very hot and/or wet. Sleeve 72 is  
removable and utilized to convert hair curler 10 to hair  
25 curler 70 when the condition of the steam warrants the  
same. Hair curler 70 is otherwise identical with hair  
curler 10.

In figure 10 there is illustrated another embodiment  
of a hair curler designated 75. Curler 75 is coreless and  
30 includes a sleeve 76 of foam polymeric plastic. The bore  
of sleeve 76 is designated 78. Sleeve 76 is telescoped  
into perforated sleeve 80 with a slight interference fit.  
Perforations 81 in sleeve 80 may be of larger diameter ad-  
jacent the central portion than adjacent the ends thereof.  
35 Sleeve 80 is made from a polymeric plastic impervious to  
liquids and has a reduced thickness at its ends.

1 A first plastic end cap 82 is snapped onto the re-  
duced thickness of sleeve 80 and closes one of sleeve 76.  
A second plastic end cap 84 is snapped onto the reduced  
thickness at the other end of sleeve 80. End cap 84 has  
5 a hole 86 coaxial with bore 78. Hole 86 has a diameter  
greater than that of bore 78. In addition to its simpli-  
city and low cost, roller 75 is readily usable by unskilled  
persons and can be attached to hair wound therearound by a  
detachable clip similar to clip 44.

10 In figure 11 there is illustrated another embodiment  
of a coreless hair curler designated 90. Curler 90 in-  
cludes a sleeve 92, like sleeve 76, telescoped into a  
sleeve 94. Sleeve 94 is the same as sleeve 80 but is  
integral in one piece with end wall 100. Sleeve 94 has  
15 rows of holes with holes 96 being smaller in diameter than  
holes 98 so the central portion of sleeve 94 is more flex-  
ible. At the end of sleeve 94 remote from wall 100, there  
is provided radially inwardly directed flange 102 terminat-  
ing at hole 104 coaxial with bore 106 in sleeve 92. The  
20 diameter of hole 104 is greater than the diameter of bore  
106 but less than the diameter of sleeve 94.

Roller 90 is comprised of only two components. The  
hole 104 is sufficiently large so that the sleeve 92 may  
be deformed and then inserted into sleeve 94. A few drops  
25 of hair conditioner may be introduced into sleeve 92 while  
it is in sleeve 94. Sleeve 94 will distribute the hair  
conditioner so that it is picked up by steam and distri-  
buted to the hair which is wound therearound.

In figure 12 there is illustrated a sleeve 108 having  
30 circumferential rows of holes 110. Holes 110 are larger  
in the central portion than near the ends of the sleeve.  
Hence the central portion is more flexible. This method  
of attaining flexibility may be used in the other embodi-  
ments discussed above in connection with sleeves 26, 54,  
35 80, 94, each of which is impervious to liquids and more  
rigid than the foam plastic sleeve associated therewith.

1           In figures 13 and 14 there is illustrated another  
embodiment of a hair curler designated generally as 112.  
Curler 112 is the same as curler 10 except as follows.  
Curler 112 has a removable core 114 having slots like core  
5 112, and over which is telescoped a sleeve 116. Sleeve 116  
is like sleeve 24 and has a slight force fit. Curler 112  
does not have a sleeve corresponding to sleeve 26. Curler  
112 may have a shield 117 which lacks a handle and which  
relies on deformation of the foam plastic sleeve 116 to  
10 facilitate attachment. Shield 117 is not connected to  
sleeve 116 or core 114 by any tabs. Shield 117 is made  
of plastic and has flexible free ends 119, 121. Shield  
117 embraces about 200 to 270° of the circumference of  
sleeve 116 and has a large number of open areas for escape  
15 of steam.

Alternatively, curler 112 may have a shield 118 as  
shown in figure 14.

The shield 118 is like shield 32 but the tabs 120  
are longer so that they cooperate with the ends of core  
20 114. If desired, shield 118 may have longitudinally ex-  
tending slots. Curler 112 may be attached to hair by a  
clip 124 which is like clip 44. Curler 112 has less parts  
and is less expensive than curler 10.

Each curler lends itself to use with a clip such as  
25 clip 44. Each curler has an opening at one end for intro-  
ducing steam thereinto. Each curler is more flexible in  
its central portion as compared with its ends.

1     CLAIMS

1           1. A hair curler characterised by a first coreless  
hollow sleeve (24) of flexible foam plastics material  
closed at one end, and a second sleeve (26) surrounding  
5     said first sleeve (24), said second sleeve (26) having  
spaced longitudinally extending aperture means (28) around  
its periphery to render the central portion of the second  
sleeve (26) flexible, the other end of said first sleeve  
(24) being arranged to receive steam.

10           2. A hair curler in accordance with claim 1,  
characterised in that said aperture means (28) are slots  
having oppositely disposed teeth (30) along the opposite  
edges of said slots.

15           3. A hair curler in accordance with claim 2,  
characterised in that said teeth (30) are arcuate and  
correspond to the circumference of the second sleeve.

20           4. A hair curler in accordance with any preceding  
claim, characterised by a shield (32) removably attached  
to the opposite ends of the second sleeve (26) and having  
its inner surface spaced from the outer surface of the  
second sleeve.

25           5. A hair curler in accordance with any preceding  
claim, characterised in that said one end of the first  
sleeve (52) is closed by a removable end cap (56').

30           6. A hair curler in accordance with claim 1,  
characterised in that said first sleeve (24) is closed  
at said one end by a removable core (12) having  
longitudinally extending slots (14).

35           7. A hair curler in accordance with claim 6,  
characterised in that said core (12) has an outer diameter  
which is slightly greater than the inner diameter of said  
first sleeve (24) so as to provide a force-fit while  
permitting removal of the core (12) by finger pressure.

          8. A hair curler in accordance with claim 6,  
characterised by a third sleeve (72) telescoped over said

1 second sleeve (26), said third sleeve (72) being of a  
foam plastics material whose radial thickness is less  
than that of the first sleeve.

5 9. A hair curler in accordance with claim 6,  
characterised in that said slots (28) of said second  
sleeve (26) have arcuate teeth (30) for catching hair.

10 10. A hair curler in accordance with claim 6,  
characterised in that the axial length of said first  
sleeve (24) is slightly greater than the axial length  
of said second sleeve (26).

15 11. A steamable hair curler characterised by a  
porous foam plastics hollow sleeve (24) surrounded by  
a second sleeve (26,80,94) of more rigid material  
impervious to liquids, said second sleeve (26,80,94)  
being substantially thinner than said first sleeve  
20 (24,92), the inner diameter of said second sleeve  
(26,80,94) being slightly smaller than the outer diameter  
of said first sleeve (24,92) so as to provide an  
interference fit therebetween, said second sleeve (26,80,  
25 94) having a plurality of openings (28,44,98) in its  
central portion to render the said portion flexible so  
that it may deform inwardly and assume a concave shape  
and through which steam may escape, and means closing  
only one end of the bore in said first-mentioned sleeve  
25 (24,92), the other end of said bore being arranged to  
receive steam.

12. A hair curler in accordance with claim 11,  
characterised in that said closing means is a perforated  
core (12) removably disposed within said bore.

30 13. A hair curler in accordance with claim 12,  
characterised in that said core (12) has an outer  
periphery which enables the core (12) to be removable  
from either end of said bore.

35 14. A hair curler in accordance with claim 11,  
characterised in that said second sleeve (94) has an end

1 wall (100) integral in one piece therewith, said end wall  
(100) being said closing means.

5 15. A hair curler in accordance with claim 14,  
characterised by drops of hair conditioner in said  
first sleeve (92).

16. A hair curler in accordance with claim 11,  
characterised in that said closing means is an end cap  
(82) attached to the outer periphery of said second sleeve  
(80).

10 17. A steamable hair curler in accordance with claim  
11, characterised by a porous foam plastics sleeve (72)  
removably telescoped over said second sleeve (26) to  
increase the heat retention of the hair curler.

15 18. A steamable hair curler characterised by a  
hollow sleeve (24,116) of foam plastics material, a hollow  
core (12, 114) having its outer periphery of uniform  
diameter and telescoped into said sleeve (24,116) with an  
interference fit, said core (12,114) being made from a  
liquid-impervious material and having a plurality of  
20 apertures (14) in a central portion thereof to facilitate  
escape of steam in a radial direction, said core (12,114)  
being closed at one end (16) and having an opening at  
its other end for receiving steam, said core (12,114)  
and sleeve (24,116) having substantially the same length.

25 19. A hair curler in accordance with claim 18,  
characterised by a shield (118) removably attached to the  
ends of said core (114) by radially disposed members  
(120), said shield (118) being spaced from the outer  
periphery of said sleeve (116) so that hair to be curled  
30 may be disposed therebetween.

20. A hair curler in accordance with claim 18,  
characterised by a shield (117) attached to the outer  
periphery of the sleeve by deformation of the sleeve  
(116), said shield (117) having at least one opening  
35 for the escape of steam and embracing 200° to 270° of  
the circumference of said sleeve (116).

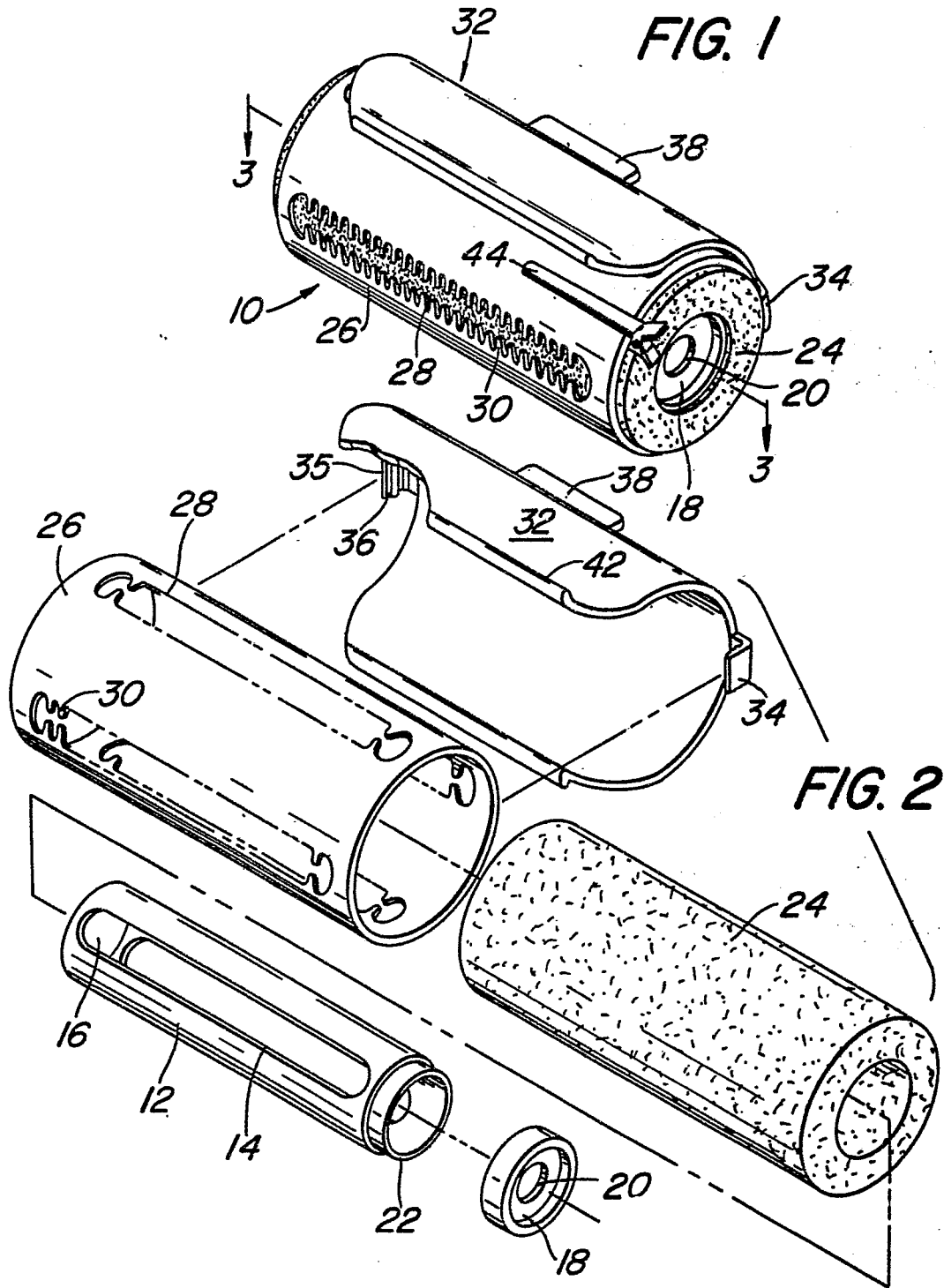

FIG. 3

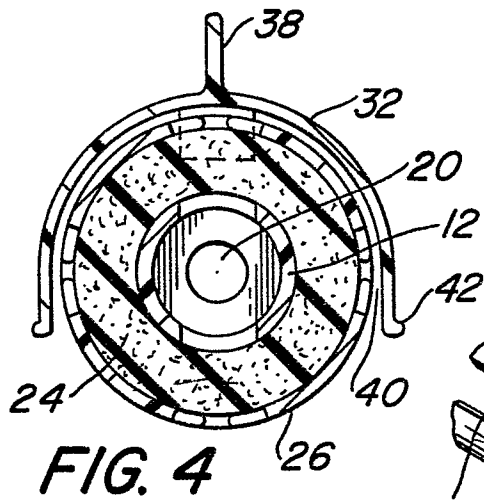
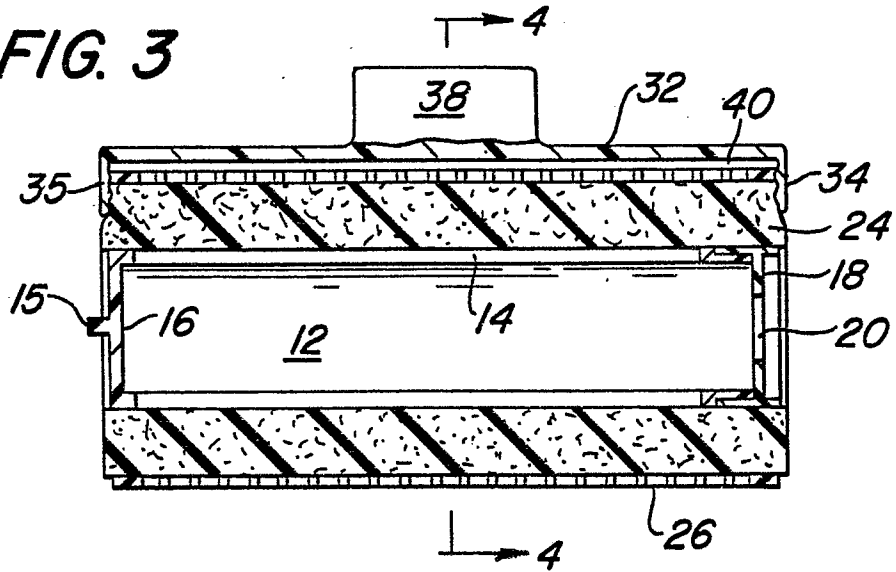

FIG. 4

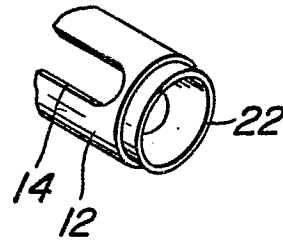

FIG. 6

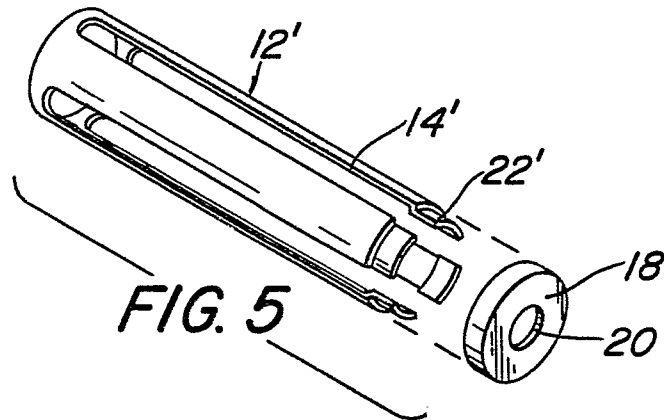

FIG. 5

FIG. 7

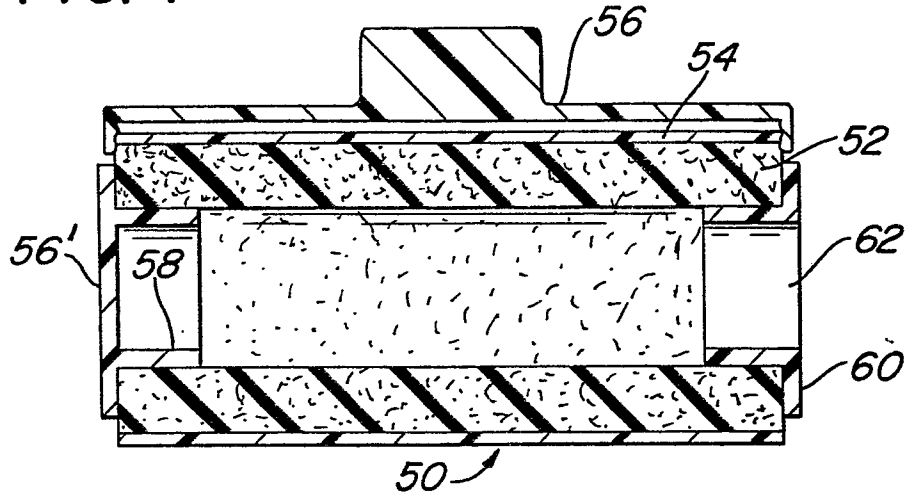

FIG. 8

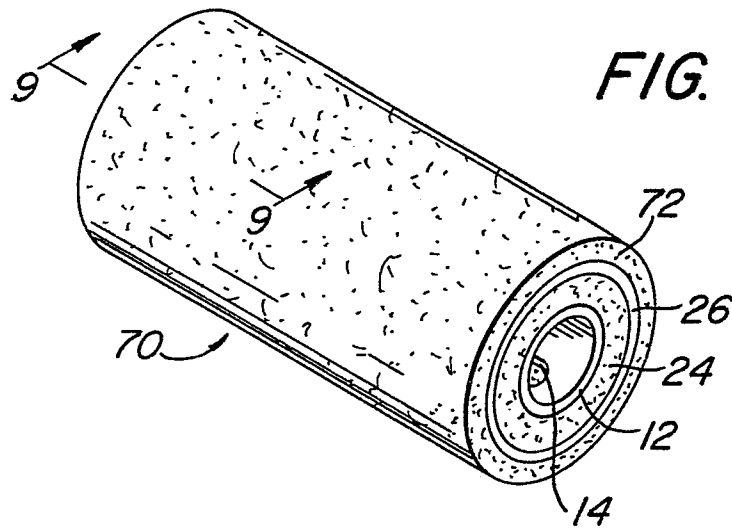
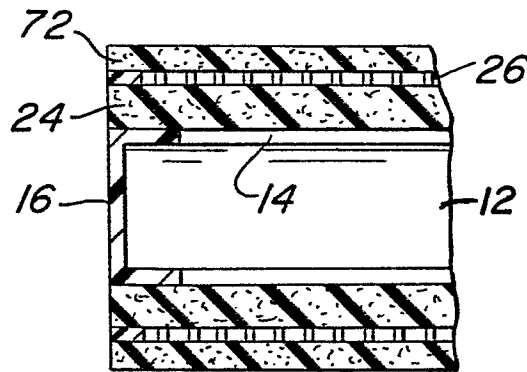

FIG. 9



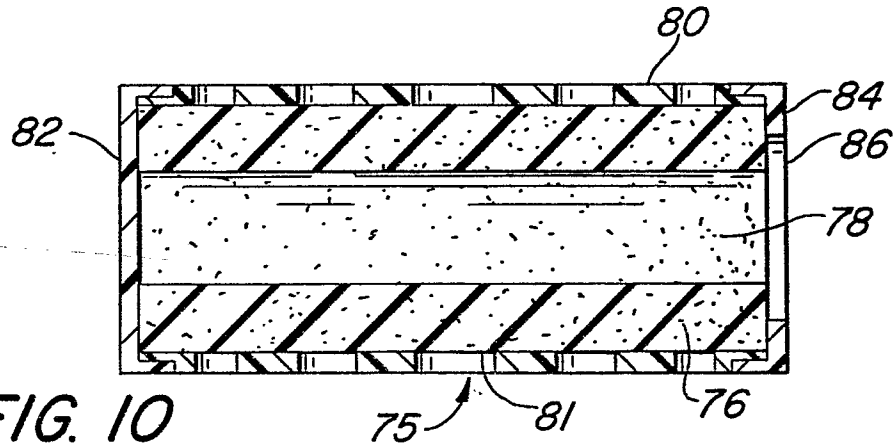

FIG. 10

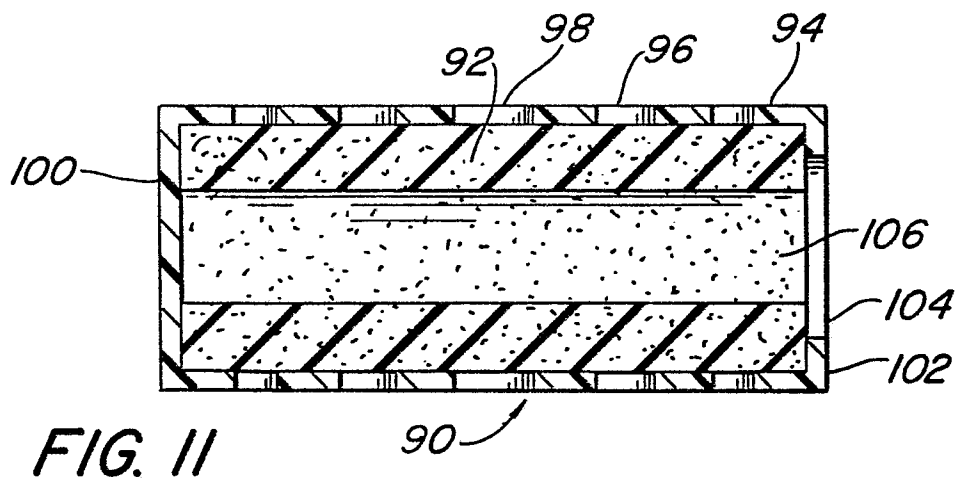

FIG. 11

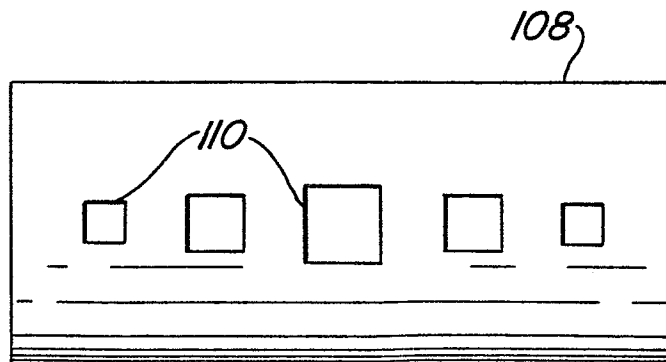
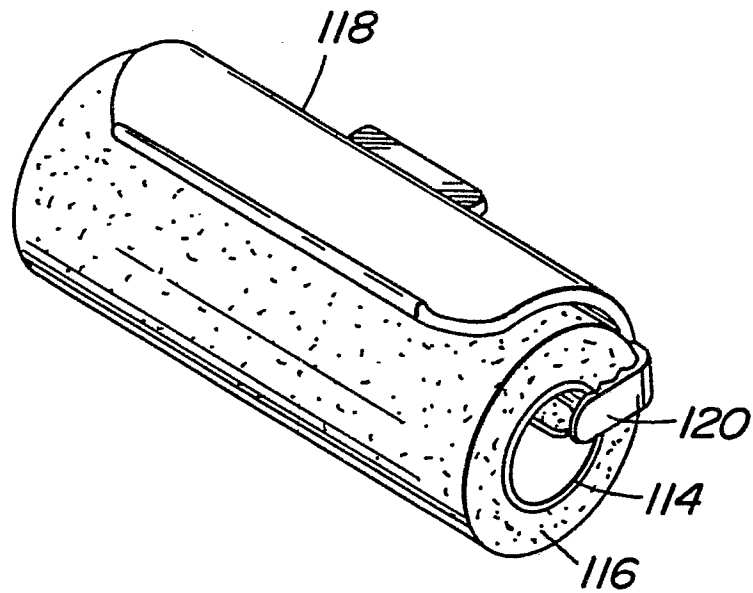
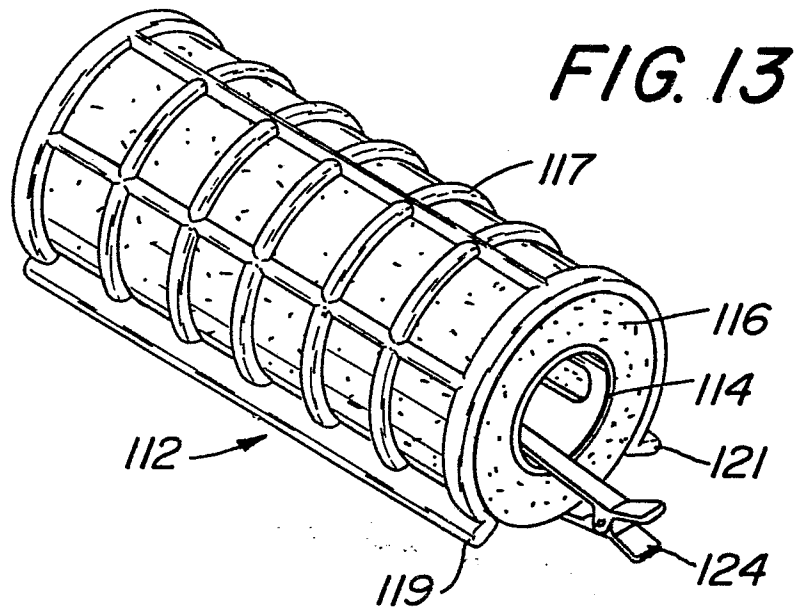

FIG. 12



**FIG. 14**



DOCUMENTS CONSIDERED TO BE RELEVANT			
Category	Citation of document with indication, where appropriate, of relevant passages	Relevant to claim	CLASSIFICATION OF THE APPLICATION (Int. Cl. 4)
A	US-A-4 453 554 (CARUSO)  * Column 3, lines 33-50; figure 11 *	1, 4, 6, 7, 11- 13, 18- 20	A 45 D 4/10
A	GB-A-2 177 636 (TAKIGAWA)  * Whole document *	1, 6, 7, 18	TECHNICAL FIELDS SEARCHED (Int. Cl. 4)  A 45 D
E	US-A-4 526 184 (CARUSO) * Whole document *	1-20	
A	US-A-3 759 271 (CARUSO)		
A	FR-A-2 539 012 (CARUSO)		
The present search report has been drawn up for all claims			
Place of search THE HAGUE		Date of completion of the search 14-11-1985	Examiner SIGWALT C.
<p><b>CATEGORY OF CITED DOCUMENTS</b></p> <p>X : particularly relevant if taken alone  Y : particularly relevant if combined with another document of the same category  A : technological background  O : non-written disclosure  P : intermediate document</p> <p>T : theory or principle underlying the invention  E : earlier patent document, but published on, or after the filing date  D : document cited in the application  L : document cited for other reasons</p> <p>&amp; : member of the same patent family, corresponding document</p>			