

(19) World Intellectual Property Organization
International Bureau



(43) International Publication Date
4 November 2004 (04.11.2004)

PCT

(10) International Publication Number
WO 2004/094918 A1

- (51) International Patent Classification⁷: F24F 1/00, 13/08
- (21) International Application Number:
PCT/KR2003/001123
- (22) International Filing Date: 9 June 2003 (09.06.2003)
- (25) Filing Language: Korean
- (26) Publication Language: English
- (30) Priority Data:
10-2003-0025818 23 April 2003 (23.04.2003) KR
10-2003-0025819 23 April 2003 (23.04.2003) KR
10-2003-0030990 15 May 2003 (15.05.2003) KR
- (71) Applicant (for all designated States except US): LG ELECTRONICS, INC. [KR/KR]; 20, Yoido-Dong, Yongsungpo-Ku, Seoul 150-010 (KR).
- (72) Inventors; and
- (75) Inventors/Applicants (for US only): KIM, In-Gyu [KR/KR]; Woosung Apt. 110-706, Poongho-Dong,

Jinhae-Shi, Kyungsangnam-Do 645-750 (KR). BAE, Young-Ju [KR/KR]; Daedong Apt. 106-503, Sangnam-Dong, Changwon-Shi, Kyungsangnam-Do 641-777 (KR). DOO, Ja-Hyung [KR/KR]; Daedong Apt. 112-405, Daebang-Dong, Changwon-Shi, Kyungsangnam-Do 641-757 (KR). PARK, Byung-II [KR/KR]; Woosung Apt. 103-905, Namyang-Dong, Changwon-Shi, Kyungsangnam-Do 641-091 (KR). KIM, Kyeong-Ho [KR/KR]; Sungwon Apt. 206-2002, Sangnam-Dong, Changwon-Shi, Kyungsangnam-Do 641-779 (KR). KIM, Yang-Ho [KR/KR]; Sungwon Apt. 206-1006, 45-1, Sangnam-Dong, Changwon-Shi, Kyungsangnam-Do 641-779 (KR). HONG, Young-Ho [KR/KR]; Daeyoung Apt. No. 305, 431-2, Yora-Ri, Jinyoung-Yup, Kimhae-Shi, Kyungsangnam-Do 621-805 (KR). HEO, Kyeong-Wook [KR/KR]; Towol-Daedong Apt. 107-1004, 44-1, Sangnam-Dong, Changwon-Shi, Kyungsangnam-Do 641-830 (KR). CHA, Kang-Wook [KR/KR]; Towol-Sungwon Apt. 202-1004, 45-1, Sangnam-Dong, Changwon-Shi, Kyungsangnam-Do

[Continued on next page]

(54) Title: BUILT-IN TYPE OUTDOOR UNIT FOR AIR CONDITIONER

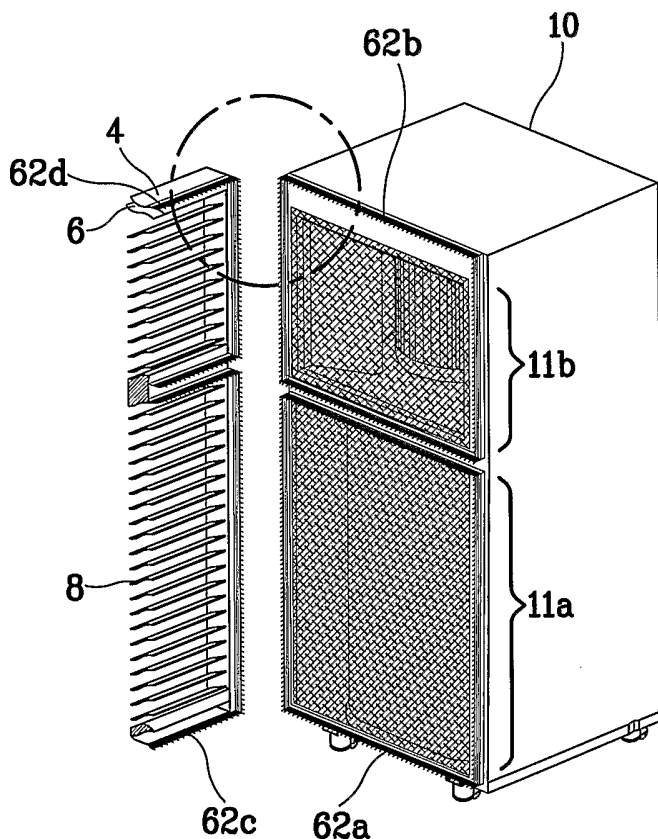

(57) Abstract: The present invention discloses a built-in type outdoor unit (10) for an air conditioner including: a louver frame (4) being fixedly installed on a rectangular space inner wall formed on an outer wall (2) of a building, being divided into a suction area (7a) and a discharge area (7b), including a plurality of louver blades (8) in each area, and sucking and discharging air through gaps between the louver blades; an outdoor unit casing being formed in a rectangular parallelepiped shape, being fixedly installed on the inside bottom of the building to contact with the louver frame, and having its one surface facing the suction area and the discharge area of the louver frame opened and the other surfaces closed; and means (62a-62d) installed on at least one of the facing surfaces of the louver frame and the outdoor unit casing, for preventing external leakage of air between the louver frame and the outdoor unit casing. A compressor (20) for compressing a refrigerant gas supplied from an indoor unit through pipe lines, an air-cooled condenser (30) for condensing the refrigerant gas from the compressor, and a cooling fan (40) for supplying external air to the air-cooled condenser through the suction area, and discharging heat exchanged air through the discharge area are installed in the outdoor unit casing.

WO 2004/094918 A1



- 641-830 (KR). **SUNG, Si-Kyong** [KR/KR]; LGE Dormitory No. 522, 14-5, Gaumjong-Dong, Changwon-Shi, Kyungsangnam-Do 641-711 (KR). **LEE, Dong-Hyuk** [KR/KR]; Sosung-Jutaek No. 7, 509-24, Yee-Dong, Jinhae-Shi, Kyungsangnam-Do 645-808 (KR). **KANG, Seong-Min** [KR/KR]; 186, Kodeok-Dong, Kangdong-Ku, Seoul 134-801 (KR). **KIM, Tae-Geun** [KR/KR]; 2nd Gaenari Apt. 204-1103, 39, Daebang-Dong, Changwon-Shi, Kyungsangnam-Do 641-804 (KR).
- (74) **Agent: LEE, Kwang-Yeon**; Lee & Kim, 5th Floor, New-Seoul Bldg., 828-8 Yoksam 1-Dong, Kangnam-Ku, Seoul 135-935 (KR).
- (81) **Designated States (national):** CN, JP, US.
- (84) **Designated States (regional):** European patent (AT, BE, BG, CH, CY, CZ, DE, DK, EE, ES, FI, FR, GB, GR, HU, IE, IT, LU, MC, NL, PT, RO, SE, SI, SK, TR).
- Published:**
— with international search report
- For two-letter codes and other abbreviations, refer to the "Guidance Notes on Codes and Abbreviations" appearing at the beginning of each regular issue of the PCT Gazette.*

BUILT-IN TYPE OUTDOOR UNIT FOR AIR CONDITIONER

TECHNICAL FIELD

The present invention relates to an outdoor unit for an air conditioner, and
5 more particularly to, a built-in type outdoor unit for an air conditioner which can be
built in an outer wall of a commercial and/or residential building.

BACKGROUND ART

An air conditioner implying a cooler, a heater or both of them is classified
10 into a window type and a split type. In the case of the cooler, a split type air
conditioner includes an indoor unit installed indoors for cooling a room, and an
outdoor unit connected to the indoor unit through refrigerant pipe lines and installed
outdoors to contact air, for performing condensation heat exchange on a refrigerant
gas in a condenser by using external air as a cooling medium, and supplying the
15 condensed refrigerants to an evaporator of the indoor unit through the refrigerant
pipe lines. The indoor unit is composed of the evaporator for performing cooling
heat exchange for evaporating the refrigerants and absorbing evaporation heat
from internal air, and a ventilating fan for circulating internal air, and the outdoor
unit is composed of a compressor for compressing the refrigerant gas and
20 supplying the compressed gas to the condenser, the air-cooled condenser for
condensing the refrigerant gas from the compressor, and a cooling fan for forcibly
ventilating external air to the air-cooled condenser to cool and condense the
refrigerant gas. The compressor, the air-cooled condenser and the cooling fan of
the outdoor unit are installed in an outdoor unit casing composing the outer
25 appearance. The conventional hexahedral outdoor unit casing has an air suction
unit for sucking air to the air-cooled condenser at its three sides, and an air

discharge unit for externally discharging air absorbing condensation heat from the refrigerant gas by the heat exchange in the air-cooled condenser on its top surface.

However, the conventional outdoor unit for the air conditioner is restricted in installation spaces due to high density and strict environment regulations of cities, and increases civil applications due to noise and heat. Especially, a common residential area such as large-scaled apartment buildings regulates the outdoor units to be installed in indoor verandas to improve the appearance and prevent noise.

In order to solve the foregoing problems, Japanese Laid-Open Patent Publication 6-101873 suggests an air conditioner mounted building where an indoor unit of an air conditioner is installed indoors or adjacent to a room intended to be air-conditioned, and an outdoor unit of the air conditioner is installed outdoors, wherein an opening is formed on the outer wall or roof, a louver is installed in the opening, the outdoor unit of the air conditioner is positioned in the louver, and suction/discharge of the indoor unit is performed through a gap between louver plates.

In addition, Japanese Laid-Open Patent Publication 3-213928 discloses a wall built-in type outdoor unit for an air conditioner including an outdoor unit main body for the air conditioner which is built in the wall and which includes a frame having the same size and thickness as the wall, a suction hole for heat exchange air installed on the same surface as the outdoor unit main body, and a discharge hole for heat exchanged air.

However, the conventional arts relate merely to technologies for inserting the outdoor unit into a space formed on an outer wall of a building. It is thus impossible to install the outdoor unit increased in size due to large air conditioning capacity in a built-in type.

Because the conventional outdoor unit is incorporated in one casing, the whole external casing must be separated or disassembled in order to manage, examine and repair its components. In addition, when the outdoor unit is built in the wall, a lot of expenses and manpower are needed to separate or disassemble the
5 external casing.

Moreover, the conventional arts have never mentioned a structure for preventing re-suction of waste air discharged through gaps between louver blades of a discharge area, or a structure for efficiently removing externally-sucked alien substances.
10

DISCLOSURE OF THE INVENTION

An object of the present invention is to provide a realistic installation structure of a built-in type outdoor unit for an air conditioner which can install a large capacity outdoor unit increased in size due to large air conditioning capacity
15 on an outer wall of a commercial and/or residential building.

Another object of the present invention is to provide a built-in type outdoor unit for an air conditioner which can prevent external leakage of air between a wall and the outdoor unit.

Yet another object of the present invention is to provide a built-in type
20 outdoor unit for an air conditioner which inserts elastic sealing members between a wall and the outdoor unit in order to absorb vibration generated in the outdoor unit.

Yet another object of the present invention is to provide an economical installation structure for efficiently installing a large capacity outdoor unit and/or services for easily transporting the outdoor unit, and examining, exchanging and
25 repairing its components, by converting capacity of the outdoor unit sucking air from three sides and discharging it to a top surface into a front suction/discharge

type, and separately installing a suction casing and a discharge casing.

Yet another object of the present invention is to provide a louver blade structure which can efficiently prevent re-suction of discharged air in a suction area, when a three side suction-top surface discharge type is converted into a front
5 suction/discharge type.

Yet another object of the present invention is to provide a louver blade structure which can efficiently remove various alien substances externally inputted during the open/close operation of louver blades, and left in a grill member mounted between a louver frame and an outdoor unit casing.

10 In order to achieve the above-described objects of the invention, there is provided a built-in type outdoor unit for an air conditioner including: a louver frame being fixedly installed on a rectangular space inner wall formed on an outer wall of a building, being divided into a suction area and a discharge area, including a plurality of louver blades in each area, and sucking and discharging air through
15 gaps between the louver blades; an outdoor unit casing being formed in a rectangular parallelepiped shape, being fixedly installed on the inside bottom of the building to contact with the louver frame, and having its one surface facing the suction area and the discharge area of the louver frame opened and the other surfaces closed; and means installed on at least one of the facing surfaces of the
20 louver frame and the outdoor unit casing, for preventing external leakage of air between the louver frame and the outdoor unit casing, wherein a compressor for compressing a refrigerant gas supplied from an indoor unit through pipe lines; an air-cooled condenser for condensing the refrigerant gas from the compressor; and
25 a cooling fan for supplying external air to the air-cooled condenser through the suction area, and discharging heat exchanged air through the discharge area are installed in the outdoor unit casing.

Here, the inside of the outdoor unit casing is divided into a suction unit and a discharge unit corresponding to the suction area and the discharge area of the louver frame, the compressor and the air-cooled condenser are installed in the suction unit, and the cooling fan is installed in the discharge unit. In addition, the outdoor unit casing includes: an outdoor unit suction casing having one opened surface facing the suction area of the louver frame, and including the compressor and the condenser; and an outdoor unit discharge casing being separated from or coupled to the outdoor unit suction casing, having one opened surface facing the discharge area of the louver frame, and including the cooling fan, wherein opened surfaces are respectively formed in the outdoor unit suction casing and the outdoor unit discharge casing to connect them to discharge the sucked air.

Preferably, the means for preventing leakage of air are zipper means installed on the facing surfaces of the louver frame and the outdoor unit casing to surround the suction area and the discharge area. In this case, one side of the zipper means is formed on the louver frame surface facing the outdoor unit casing to surround the suction area and the discharge area, and the other side of the zipper means is formed on the outdoor unit casing surface facing the louver frame to surround the suction unit and the discharge unit. In addition, the zipper means are respectively installed on long connecting members installed on the louver frame surface and the outdoor unit casing surface facing each other. The connecting members of the louver frame respectively surround the suction area and the discharge area, and the connecting members of the outdoor unit casing respectively surround the suction unit and the discharge unit. Vibration isolating members for absorbing vibration generated in the outdoor unit are further installed between the connecting members and the zipper means. The vibration isolating members are long bellows shaped members. In addition, the vibration isolating

members can be long elastic bag shaped members. Because a width of the outdoor unit casing is smaller than a width of the louver frame fixedly installed on the outer wall of the building, the outdoor unit can be installed by sealing up the space between the louver frame and the outdoor unit casing by running up the zipper means installed on the outdoor unit casing surface and the louver frame surface facing each other, and fixing the outdoor unit casing and the louver frame by using fastening members.

The means for preventing leakage of air are long extended elastic sealing members formed on at least one of the facing surfaces of the louver frame and the outdoor unit casing, for surrounding the suction area and the discharge area when the louver frame and the outdoor unit casing are fastened. In this case, special elastic sealing members for respectively surrounding the suction area and the discharge area can be formed. Reinforcing ribs for preventing lateral movement of the elastic sealing members are additionally formed. The elastic sealing members include hollow units shrunken when the louver frame and the outdoor unit casing are fastened. Because a width of the outdoor unit casing is smaller than a width of the louver frame fixedly installed on the outer wall of the building, the outdoor unit can be installed by sealing up the space between the louver frame and the outdoor unit casing by the elastic sealing members shrunken due to approaches of the outdoor unit casing surface and the louver frame surface facing each other, and fixing the outdoor unit casing and the louver frame by using fastening members. Here, the fastening members are 'L' shaped brackets. Preferably, the fastening member includes a first connecting bracket fixed to the louver frame, a second connecting bracket fixed to the outdoor unit casing, and a vibration isolating bracket connected between the first and second connecting brackets. Here, the vibration isolating bracket is a spring. In addition, the vibration isolating bracket can

be formed in a bellows shape.

The louver blades have wave-shaped curved sections. In this case, the louver blades of the discharge area have wave-shaped curved sections whose ends are upwardly inclined in order to discharge air in the upward direction, and the
5 louver blades of the suction area have wave-shaped curved sections whose ends are downwardly inclined in order to suck air from their lower portions.

In addition, a grill member for preventing external alien substances is further installed between the louver frame and the outdoor unit casing, and the louver blades further include elastic contact members in the outdoor unit casing area, so
10 that the elastic contact members can contact with the grill member according to the open/close operation of the louver blades. In this case, more preferably, when the louver blades are closed, the elastic contact members do not contact with the grill member, and when the louver blades are opened, the elastic contact members contact with the grill member.

15 According to another aspect of the invention, a built-in type outdoor unit for an air conditioner includes: a louver frame being fixedly installed on a rectangular space inner wall formed on an outer wall of a building, being divided into a suction area and a discharge area, including a plurality of louver blades in each area, and sucking and discharging air through gaps between the louver blades; and an
20 outdoor unit casing fixedly installed to contact with the louver frame, formed in a rectangular parallelepiped shape having its one side facing the suction area and the discharge area of the louver frame opened and its top surface, bottom surface and three sides closed, and divided into a suction unit and a discharge unit corresponding to the suction area and the discharge area of the louver frame,
25 wherein the louver blades have wave-shaped curved sections.

Here, the louver blades of the discharge area have wave-shaped curved

sections whose ends are upwardly inclined in order to discharge air in the upward direction, and the louver blades of the suction area have wave-shaped curved sections whose ends are downwardly inclined in order to suck air from their lower portions. More preferably, an open state, a close state and/or an open angle of the louver blades are controlled. Here, a grill member for preventing external alien substances is further installed between the louver frame and the outdoor unit casing, and the louver blades further include elastic contact members in the outdoor unit casing area, so that the elastic contact members can contact with the grill member according to the open/close operation of the louver blades. In this case, more preferably, when the louver blades are closed, the elastic contact members do not contact with the grill member, and when the louver blades are opened, the elastic contact members contact with the grill member.

According to another aspect of the invention, a built-in type outdoor unit for an air conditioner includes: a louver frame being fixedly installed on a rectangular space inner wall formed on an outer wall of a building, being divided into a suction area and a discharge area, including a plurality of louver blades which can be opened/closed in each area, and sucking and discharging air through gaps between the opened louver blades; an outdoor unit casing fixedly installed to contact with the louver frame, formed in a rectangular parallelepiped shape having its one side facing the suction area and the discharge area of the louver frame opened and its top surface, bottom surface and three sides closed, and divided into a suction unit and a discharge unit corresponding to the suction area and the discharge area of the louver frame; and a grill member installed between the louver frame and the outdoor unit casing, for preventing external alien substances, wherein the louver blades further include elastic contact members in the outdoor unit casing area, so that the elastic contact members can contact with the grill

member according to the open/close operation of the louver blades.

More preferably, when the louver blades are closed, the elastic contact members do not contact with the grill member, and when the louver blades are opened, the elastic contact members contact with the grill member.

5

BRIEF DESCRIPTION OF THE DRAWINGS

Fig. 1 is a partially-cut perspective-sectional view illustrating a built-in type outdoor unit for an air conditioner in accordance with a preferred embodiment of the present invention;

10 Fig. 2 is an exemplary view illustrating installation and assembly of the outdoor unit of Fig. 1;

Fig. 3 is a perspective view illustrating disassembly of the outdoor unit of Fig. 1;

15 Figs. 4A to 4C are a perspective view, a partially-enlarged perspective view and a partially-enlarged cross-sectional view respectively illustrating a zipper means of the outdoor unit of Fig. 1, Fig. 4D is a perspective view illustrating zipper means of an outdoor unit in accordance with another embodiment of the present invention, and Fig. 4E is a partially-cut plan view illustrating mounted constitution of a louver frame and the outdoor unit in accordance with the present invention;

20 Figs. 5A to 5C are a perspective view, a partially-enlarged perspective view and a partially-enlarged cross-sectional view respectively illustrating elastic sealing members of the outdoor unit of Fig. 1, Fig. 5D is a perspective view illustrating elastic sealing members of an outdoor unit in accordance with another embodiment of the present invention, and Figs. 5E to 5G are partially-cut plan
25 views illustrating various mounted constitutions of a louver frame and the outdoor unit in accordance with the present invention;

Fig. 6 is a schematic cross-sectional view illustrating a shape of louver blades in accordance with the present invention; and

Figs. 7A to 7C are schematic views respectively illustrating an open/close operation of louver blades in accordance with another embodiment of the present invention, wherein Fig. 7A shows the closed louver blades, Fig. 7B shows the opened louver blades, and Fig. 7C shows assembly of elastic contact members.

BEST MODE FOR CARRYING OUT THE INVENTION

A built-in type outdoor unit for an air conditioner in accordance with the present invention will now be described in detail with reference to the accompanying drawings.

As illustrated in Figs. 1 and 2, an external frame 4 is fixedly installed on a rectangular space inner wall formed on an outer wall 2 of a residential and/or commercial building, and an internal frame 6 is fixedly installed at the inside of the external frame 4. The internal and external frames 4 and 6 can be incorporated. An inside area of the internal frame 6 is divided into a suction area 7a and a discharge area 7b. A plurality of louver blades 8 are installed in each area, so that air can be sucked or discharged through gaps between the louver blades 8. Hereinafter, the external frame 4, the internal frame 6 and the louver blades 8 are referred to as a louver frame.

On the other hand, an outdoor unit 10 (partially shown) fixedly installed at the inside of the outer wall 2 of the building to contact with the external frame 4 and/or internal frame 6 includes an outdoor unit casing. The outdoor unit casing opens its one side facing the suction area 7a and the discharge area 7b of the internal frame 6. The opened side is divided into a suction unit 11a and a discharge unit 11b to correspond to the suction area 7a and the discharge area 7b of the

internal frame 6.

The louver frame coupled to or separated from the outdoor unit 10 includes an isolating unit 9 for dividing the louver blades 8 of the suction area 7a from the louver blades 8 of the discharge area 7b. The isolating unit 9 isolates the suction
5 area 7a of the louver frame from the discharge area 7b at a predetermined interval, to prevent interferences between external air sucked to the suction area 7a and heat exchanged air discharged from the discharge area 7b. Accordingly, the front suction/discharge type outdoor unit 10 rapidly sucks external air and discharges heat exchanged air. In addition, the isolating unit 9 prevents air discharged from
10 the louver blades 8 at the lower end of the discharge area 7b from being re-sucked to the louver blades 8 at the upper end of the suction area 7a, namely isolates air of the suction area 7a from air of the discharge area 7b, to minimize contacts of air sucked to the suction area 7a and heat exchanged air discharged from the discharge area 7b. The isolating unit 9 includes a slanted surface to externally
15 discharge rain or snow flowing down by the louver blades 8 of the discharge area 7b (briefly shown in Fig. 6).

An air suction/discharge direction can be controlled by adjusting an open angle of the louver blades 8. In addition, an air suction direction and an air discharge direction can be distinguished by controlling the louver blades 8 of the
20 suction area 7a and the discharge area 7b to have different open angles. A manual open device (not shown) operated by force of the user, and an automatic open device (not shown) for automatically operating the louver blades 8 according to the operation of an outdoor unit 10, namely a control command of the outdoor unit 10 performing a series of operations for cooling/heating can be used as a control
25 means for opening the louver blades 8. The structure and constitution of the manual open device and the automatic open device for the louver blades 8 are

easily understood by the ordinary people skilled in the art which the present invention pertains to. It is possible to determine the air suction/discharge direction in consideration of an external environment, and to open and maintain the louver blades 8 in a predetermined direction.

5 On the other hand, the outdoor unit 10 fixedly installed at the inside of the outer wall 2 of the building to contact with the external frame 4 and/or internal frame 6 includes an outdoor unit casing composed of components of Fig. 3. In addition, outdoor unit components of Fig. 3 are installed in the outdoor unit casing.

 In the outdoor unit casing, one side facing the suction area 7a and the discharge area 7b of the internal frame 6 is opened. The opened side is divided
10 into a suction unit 11a and a discharge unit 11b to correspond to the suction area 7a and the discharge area 7b of the internal frame 6. In addition, three side covers 12a, 12b and 12c, a bottom cover 14 and a top cover 16 are closed to form a rectangular parallelepiped. A plurality of leg members 18a, 18b, 18c and 18d are
15 externally protruded from the bottom cover 14. The leg members 18a, 18b, 18c and 18d are installed on the bottom of a building, for example a veranda of an apartment building, for supporting heavy load of the outdoor unit 10. Preferably, four leg members 18a, 18b, 18c and 18d are formed in consideration of the shape of the bottom cover 14. Leg reinforcing members 19 for connecting and reinforcing
20 the leg members 18a, 18b, 18c and 18d are formed below the bottom cover 14 in the horizontal direction. The leg members 18a, 18b, 18c and 18d further include screws (not shown) for controlling height. Accordingly, when the bottom of the building, for example the veranda of the apartment building is not flat, they can stably position the outdoor unit 10. When the two leg members 18a and 18b
25 positioned in the forward direction (toward building outer wall) among the leg members 18a, 18b, 18c and 18d further include transport wheels (not shown), it is

much easier to transport the heavy load outdoor unit 10.

In the outdoor unit suction unit 11a, a compressor 20 is installed on a compressor fastening unit 22, and a 'U' shaped air-cooled condenser 30 is fixedly supported on the side covers 12a and 12b and the bottom cover 14 by using condenser covers 32a, 32b and 32c and condenser brackets 34a and 34b. In the
5 air-cooled condenser 30, a plurality of condenser pipe lines are formed in a zigzag shape between a plurality of condenser fins. The structure and shape of the air-cooled condenser 30 have been publicly known, and thus are not shown in detail. A refrigerant gas compressed by the compressor 20 is transmitted through
10 the pipe lines of the condenser 30, removed its condensation heat by externally-supplied air, and condensed. In this case, the condenser covers 32a, 32b and 32c and the condenser brackets 34a and 34b form a wind path so as to prevent external air from being supplied to the discharge unit 11b not via the condenser 30. As a result, external air sucked through the gaps between the louver
15 blades 8 of the suction area 7a passes through the 'U' shaped condenser 30 along the wind path of the condenser covers 32a, 32b and 32c and the condenser brackets 34a and 34b, and exchanges heat with the refrigerant gas flowing through the condenser pipe lines.

In the outdoor unit discharge unit 11b, a cooling fan 40 for supplying
20 external air to the air-cooled condenser 30 through the suction area 7a and discharging heat exchanged air through the discharge area 7b is fixedly installed on the side covers 12a, 12b and 12c and the top cover 16 by a cooling fan supporting member 42, a cooling fan bracket 44 and a fan front 46. Here, a sirocco fan is used as the cooling fan 40.

25 A control box 50 for controlling the operation of the outdoor unit 10 is installed at the inside of the side cover 12c composing the rear surface among the

side covers, and refrigerant pipe lines which the refrigerant gas evaporated in the indoor unit is sucked through, and a valve assembly 52, a path of the refrigerant pipe lines which the refrigerants condensed in the outdoor unit 10 are discharged through are installed below the control box 50.

5 A mesh shaped grill member 60 is installed on the front surface of the outdoor unit 10, namely one opened side facing the suction area 7a and the discharge area 7b of the internal frame 6 to prevent invasion of animals (for example, rats) or inflow of alien substances. As shown in Fig. 4A, zipper means 62a, 62b, 62c and 62d are respectively installed on the facing surfaces of the
10 louver frame and the outdoor unit casing to surround the suction unit 11a and the discharge unit 11b.

In more detail, one side 62a and 62b of the zipper means is formed on the outdoor unit casing surface facing the louver frame to surround the suction unit 11a and the discharge unit 11b, and the other side 62c and 62d of the zipper means is
15 formed on the louver frame surface facing the outdoor unit casing to surround the suction area 7a and the discharge area 7b. The zipper means 62a, 62b, 62c and 62d prevent leakage of air between the louver frame and the outdoor unit 10, so that external air passing through the suction area 7a of the louver frame can be sucked through the suction unit 11a of the outdoor unit casing, and heat
20 exchanged air discharged from the discharge unit 11b of the outdoor unit casing can be externally discharged through the discharge area 7b of the louver frame.

As illustrated in Fig. 4B, long connecting members 64a, 64b, 64c and 64d for fixedly connecting the zipper means 62a, 62b, 62c and 62d are installed on the louver frame surface and the outdoor unit casing surface facing each other. In
25 more detail, the connecting members 64a and 64b of the outdoor unit casing respectively surround the suction unit 11a and the discharge unit 11b, and the

connecting members 64c and 64d of the louver frame respectively surround the suction area 7a and the discharge area 7b.

Moreover, vibration isolating members 66a, 66b, 66c and 66d for absorbing vibration generated in the outdoor unit 10 are installed between the connecting members 64a, 64b, 64c and 64d and the zipper means 62a, 62b, 62c and 62d. The zipper means 62a, 62b, 62c and 62d can be directly connected to the connecting members 64a, 64b, 64c and 64d. As shown in Figs. 4A to 4C, the zipper means 62a, 62b, 62c and 62d and the connecting members 64a, 64b, 64c and 64d are connected by the vibration isolating members 66a, 66b, 66c and 66d.

In accordance with the present invention, the outdoor unit 10 absorbs vibration generated in the cooling fan 40, by inserting the vibration isolating members 66a, 66b, 66c and 66d into the whole surface of the outdoor unit casing. Thus, the vibration is not transmitted to the louver frame and/or outer wall. When the outdoor unit 10 is installed, the zipper means 62a, 62b, 62c and 62d can be easily run up due to elasticity of the vibration isolating means 66a, 66b, 66c and 66d. The vibration isolating members are long bellows shaped members, long elastic bag shaped members, or different shaped elastic members.

Fig. 4C is a cross-sectional view illustrating assembly of the zipper means and the outdoor unit. The zipper means 62a is fixed to the outdoor unit casing by the connecting member 64a. Here, the zipper means 62a is connected to the connecting member 64a by the vibration isolating member 66a. The other zipper means 62b, 62c and 62d, the connecting members 64b, 64c and 64d and the vibration isolating members 66b, 66c and 66d have the same structure. The connecting members 64a, 64b, 64c and 64d are coupled to the outdoor unit casing and the louver frame by welding, or using fastening means (for example, screws).

Fig. 4D is a perspective view illustrating an outdoor unit casing in

accordance with another embodiment of the present invention. Referring to Fig. 4D, an outdoor unit 100 includes a separable outdoor unit suction casing 11c and a separable outdoor unit discharge casing 11d. Here, the outdoor unit suction casing 11c and the outdoor unit discharge casing 11d have their one surface opened to correspond to the suction area 7a and the discharge area 7b of the louver frame, and have their another surface connected to move heat exchanged air. That is, the outdoor unit suction casing 11c corresponds to the suction unit 11a of the outdoor unit 10, and the outdoor unit discharge casing 11d corresponds to the discharge unit 11b of the outdoor unit 10. The outdoor unit suction casing 11c and the outdoor unit discharge casing 11d can be coupled to or separated from each other by using a special fastening device (bolts and nuts, guide holes and hooks, etc.) (not shown).

The outdoor unit 100 which can be assembled/disassembled reduces its whole weight and size to be easily transported and moved. The outdoor unit 100 can also be easily installed by firstly installing the outdoor unit suction casing 11c, and then installing the outdoor unit discharge casing 11d. For management and repair, the outdoor unit 100 is partially separated and disassembled so that its inside components can be examined. That is, the outdoor unit 100 has a simplified structure in time and cost.

Still referring to Fig. 4D, the outdoor unit suction casing 11c and the discharge casing 11d respectively include zipper means 68a and 68b on their surfaces facing the louver frame surface, and the louver frame includes zipper means 68c and 68d on its surface facing the outdoor unit casing. That is, the zipper means of Figs. 4A to 4C are used in the same manner. The zipper means 68a, 68b, 68c and 68d are respectively fixed to the outdoor unit suction casing 11c, the discharge casing 11d and the louver frame by connecting members (not shown),

and vibration isolating members (not shown) are installed between the zipper means 68a, 68b, 68c and 68d and the connecting members.

Fig. 4E is a partially-cut plan view illustrating mounted constitution of the louver frame and the outdoor unit in accordance with the present invention. As depicted in Fig. 5, a width of the outdoor unit 10 is smaller than an internal space width of the external frame 4 fixedly installed at the inside of the outer wall. Accordingly, the space between the louver frame and the outdoor unit casing is sealed up by running up the zipper means 62a and 62c installed on the outdoor unit casing surface and the louver frame surface facing each other, and the outdoor unit casing and the louver frame are fixed to the external frame 4 and the side covers 12a and 12b of the outdoor unit 10 by using special fastening members, for example 'L' shaped brackets 70. In this case, the outdoor unit 10 is not fixed to the concrete outer wall 2, and thus easily installed. A gap is formed between the concrete outer wall 2 and the outdoor unit 10 as large as the external frame 4, so that the outdoor unit 10 can be easily fixed and installed. In addition, the separable outdoor unit 100 can use fastening members like the outdoor unit 10.

As illustrated in Fig. 5A, grooves 71 (shown in detail in Fig. 5C) are formed on at least one of the facing surfaces of the louver frame and the outdoor unit casing, and long extended elastic sealing members 72a and 72b are inserted into the grooves 71 to respectively surround the suction area 7a and the discharge area 7b, when the louver frame and the outdoor unit casing are fastened.

External leakage of air is prevented between the louver frame and the outdoor unit casing by inserting the elastic sealing members 72a and 72b. In addition, the outdoor unit 10 absorbs vibration generated in the cooling fan 40 so that the vibration cannot be transmitted to the louver frame and/or outer wall. According to another aspect of the invention, a groove is formed on the louver

frame surface to surround the suction area 7a and the discharge area 7b, and an elastic sealing member is inserted into the groove. As shown in Figs. 5A and 5B, reinforcing ribs 74a and 74b are used to prevent lateral movement of the elastic sealing members 72a and 72b.

5 As depicted in Fig. 5C, the elastic sealing member 72b is inserted into the groove 71 formed on the louver frame surface facing the outdoor unit 10, and supported by the reinforcing ribs 74a and 74b. The elastic sealing member 72b includes a hollow unit 76. Therefore, when the louver frame and the outdoor unit 10 are fastened, the elastic sealing member 72b is remarkably shrunken to efficiently
10 absorb vibration and remove a gap between the louver frame and the outdoor unit 10, thereby preventing leakage of air. In more detail, air sucked through one opened surface and the suction area 7a of the louver frame is supplied to the suction unit 11a of the outdoor unit 10, and heat exchanged air discharged from the discharge unit 11b of the outdoor unit 10 is externally discharged through the
15 discharge area 7b of the louver frame.

Identically to Fig. 4D, Fig. 5D shows an outdoor unit 100 including a separable outdoor unit suction casing 11c and a separable outdoor unit discharge casing 11d in accordance with another embodiment of the present invention. As shown in Fig. 5D, the outdoor unit 100 can also use elastic sealing members.

20 Figs. 5E to 5G are partially-cut plan views illustrating various mounted constitutions of the louver frame and the outdoor unit in accordance with the present invention.

As depicted in Fig. 5E, a width of the outdoor unit 10 is smaller than an internal space width of the external frame 4 fixedly installed at the inside of the
25 outer wall. Accordingly, the space between the louver frame and the outdoor unit casing is sealed up by elastic sealing members 72a and 72b (72a is not shown)

shrunken due to approaches of the outdoor unit 10 and the louver frame facing each other, and the outdoor unit 10 and the louver frame are fixed to the external frame 4 and the side covers 12a and 12b of the outdoor unit 10 by using special fastening members, for example 'L' shaped brackets 80. In this case, the outdoor
5 unit 10 is not fixed to the concrete outer wall 2, and thus easily installed. A gap is formed between the concrete outer wall 2 and the outdoor unit 10 as large as the external frame 4, so that the outdoor unit 10 can be easily fixed and installed.

As another example of the fastening member of Fig. 5E, as shown in Fig. 5F, a connecting bracket 82a is fixed to the louver frame, a connecting bracket 82b
10 is fixed to the outdoor unit 10, and a vibration isolating bracket, for example a spring 84 for preventing vibration of the outdoor unit 10 (especially generated by the cooling fan 40) from being transmitted to the louver frame and/or outer wall 2 is installed between the connecting brackets 82a and 82b. The outdoor unit 10 is not fixed to the concrete outer wall 2 by using the spring 84, and thus is easily installed.
15 In addition, the outdoor unit 10 is approached to the louver frame due to elasticity of the spring 84, and thus easily installed.

As another example of the vibration isolating bracket of Fig. 5F, as shown in Fig. 5G, connecting brackets 82a and 82b are respectively fixed to the louver frame and the outdoor unit 10, and a bellows 86 is installed between the connecting
20 brackets 82a and 82b as a vibration isolating bracket. The outdoor unit 10 is not fixed to the concrete outer wall 2 by using the bellows 86, and thus is easily installed. In addition, the outdoor unit 10 is approached to the louver frame due to elasticity of the bellows 86, and thus easily installed. The separable outdoor unit
25 outdoor unit 10.

As confirmed in Fig. 6, the louver blades 8 of the suction area 7a have

wave-shaped curved sections whose ends are downwardly inclined in order to suck air from their lower portions, and the louver blades 8 of the discharge area 7b have wave-shaped curved sections whose ends are upwardly inclined in order to discharge air in the upward direction. As described above, when the louver blades 8 have straight line-shaped sections, the isolating unit 9 must be formed between the suction area 7a and the discharge area 7b to prevent waste air discharged through the gaps between the louver blades 8 of the discharge area 7b from being re-sucked through the suction area 7a. However, as illustrated in Fig. 6, the louver blades 8 guide waste air in the upward direction, and suck external fresh air from their lower portions in the suction area 7a. As a result, heat exchanged and discharged air is rarely sucked through the gaps between the louver blades 8 of the suction area 7a. Still referring to Fig. 6, the louver blades 8 have wave-shaped curved sections, and thus prevent rain drops from being inserted.

The open/close operation of the louver blades 8 can be controlled. The present invention provides a structure for removing alien substances left in the mesh-shaped grill member 60 installed between the louver frame and the outdoor unit casing for preventing the alien substances during the open/close operation of the louver blades 8. As illustrated in Figs. 7A and 7B, elastic contact members 8a are mounted on the outdoor unit casing side area of the louver blades 8. As depicted in Fig. 7B, when the louver blades 8 are opened, the elastic contact members 8a sweep the mesh-shaped grill member 60, to remove alien substances such as dust accumulated or left in the mesh-shaped grill member 60. Fig. 7B shows a state where the louver blades 8 are completely opened or half opened. If the louver blades 8 are half opened, when the louver blades 8 are completely opened and closed, the elastic contact members 8a re-sweep the mesh-shaped grill member 60. It can be varied by an operator.

An elastic member such as a rubber plate can be used as the elastic contact member 8a. Preferably, as shown in Fig. 7C, the elastic contact member 8a is inserted into a groove unit 8b of the louver blades 8.

Figs. 7A to 7C show the elastic contact members 8a such as rubber plates
5 mounted on the louver blades 8 having straight-line shaped sections. However, as depicted in Fig. 6, the elastic contact members 8a can also be mounted on the louver blades 8 having wave-shaped curved sections. In the same manner, when the louver blades 8 are closed, the elastic contact members 8a do not contact with the grill member 60, and when the louver blades 8 are opened, the elastic contact
10 members 8a sweep the grill member 60, to remove alien substances such as dust accumulated or left in the grill member 60. Here, an opening degree of the louver blades 8 can be determined by the operator.

Although the preferred embodiments of the present invention have been described, it is understood that the present invention should not be limited to these
15 preferred embodiments but various changes and modifications can be made by one skilled in the art within the spirit and scope of the present invention as hereinafter claimed.

What is claimed is:

1. A built-in type outdoor unit for an air conditioner, comprising:

a louver frame being fixedly installed on a rectangular space inner wall
5 formed on an outer wall of a building, being divided into a suction area and a
discharge area, including a plurality of louver blades in each area, and sucking and
discharging air through gaps between the louver blades;

an outdoor unit casing being formed in a rectangular parallelepiped shape,
being fixedly installed on the inside bottom of the building to contact with the louver
10 frame, and having its one surface facing the suction area and the discharge area of
the louver frame opened and the other surfaces closed; and

means installed on at least one of the facing surfaces of the louver frame
and the outdoor unit casing, for preventing external leakage of air between the
louver frame and the outdoor unit casing,

15 wherein a compressor for compressing a refrigerant gas supplied from an
indoor unit through pipe lines; an air-cooled condenser for condensing the
refrigerant gas from the compressor; and a cooling fan for supplying external air to
the air-cooled condenser through the suction area, and discharging heat
exchanged air through the discharge area are installed in the outdoor unit casing.

20

2. The outdoor unit of claim 1, wherein the inside of the outdoor unit casing
is divided into a suction unit and a discharge unit corresponding to the suction area
and the discharge area of the louver frame, the compressor and the air-cooled
condenser are installed in the suction unit, and the cooling fan is installed in the
25 discharge unit.

3. The outdoor unit of claim 1, wherein the outdoor unit casing comprises:
an outdoor unit suction casing having one opened surface facing the
suction area of the louver frame, and including the compressor and the condenser;
and
5 an outdoor unit discharge casing being separated from or coupled to the
outdoor unit suction casing, having one opened surface facing the discharge area
of the louver frame, and including the cooling fan,
wherein opened surfaces are respectively formed in the outdoor unit
suction casing and the outdoor unit discharge casing to connect them to discharge
10 the sucked air.

4. The outdoor unit of one of claims 1 to 3, wherein the means for
preventing leakage of air are zipper means installed on the facing surfaces of the
louver frame and the outdoor unit casing to surround the suction area and the
15 discharge area.

5. The outdoor unit of claim 4, wherein one side of the zipper means is
formed on the louver frame surface facing the outdoor unit casing to surround the
suction area and the discharge area, and the other side of the zipper means is
20 formed on the outdoor unit casing surface facing the louver frame to surround the
suction unit and the discharge unit.

6. The outdoor unit of claim 5, wherein the zipper means are respectively
installed on long connecting members installed on the louver frame surface and the
25 outdoor unit casing surface facing each other.

7. The outdoor unit of claim 6, wherein the connecting members of the louver frame respectively surround the suction area and the discharge area, and the connecting members of the outdoor unit casing respectively surround the suction unit and the discharge unit.

5

8. The outdoor unit of claim 6, wherein vibration isolating members for absorbing vibration generated in the outdoor unit are further installed between the connecting members and the zipper means.

10 9. The outdoor unit of claim 8, wherein the vibration isolating members are long bellows shaped members.

10. The outdoor unit of claim 8, wherein the vibration isolating members are long elastic bag shaped members.

15

11. The outdoor unit of one of claims 8 to 10, which is installed by sealing up the space between the louver frame and the outdoor unit casing by running up the zipper means installed on the outdoor unit casing surface and the louver frame surface facing each other, and fixing the outdoor unit casing and the louver frame by using fastening members, because a width of the outdoor unit casing is smaller than a width of the louver frame fixedly installed on the outer wall of the building,

12. The outdoor unit of one of claims 1 to 3, wherein the means for preventing leakage of air are long extended elastic sealing members formed on at least one of the facing surfaces of the louver frame and the outdoor unit casing, for surrounding the suction area and the discharge area when the louver frame and

25

the outdoor unit casing are fastened.

13. The outdoor unit of claim 12, wherein elastic sealing members are formed to respectively surround the suction area and the discharge area.

5

14. The outdoor unit of claim 13, wherein reinforcing ribs are further formed to prevent lateral movement of the elastic sealing members.

15. The outdoor unit of claim 14, wherein the elastic sealing members
10 comprise hollow units shrunken when the louver frame and the outdoor unit casing are fastened.

16. The outdoor unit of claim 15, which is installed by sealing up the space
15 between the louver frame and the outdoor unit casing by the elastic sealing members shrunken due to approaches of the outdoor unit casing surface and the louver frame surface facing each other, and fixing the outdoor unit casing and the louver frame by using fastening members, because a width of the outdoor unit casing is smaller than a width of the louver frame fixedly installed on the outer wall of the building.

20

17. The outdoor unit of claim 16, wherein the fastening members are 'L' shaped brackets.

18. The outdoor unit of claim 16, wherein the fastening member comprises
25 a first connecting bracket fixed to the louver frame, a second connecting bracket fixed to the outdoor unit casing, and a vibration isolating bracket connected

between the first and second connecting brackets.

19. The outdoor unit of claim 18, wherein the vibration isolating bracket is a spring.

5

20. The outdoor unit of claim 19, wherein the vibration isolating bracket is formed in a bellows shape.

21. The outdoor unit of one of claims 1 to 20, wherein the louver blades
10 have wave-shaped curved sections.

22. The outdoor unit of claim 21, wherein the louver blades of the discharge area have wave-shaped curved sections whose ends are upwardly inclined in order to discharge air in the upward direction.

15

23. The outdoor unit of claim 21, wherein the louver blades of the suction area have wave-shaped curved sections whose ends are downwardly inclined in order to suck air from their lower portions.

20 24. The outdoor unit of one of claims 1 to 20, wherein a grill member for preventing external alien substances is further installed between the louver frame and the outdoor unit casing, and the louver blades further comprise elastic contact members in the outdoor unit casing area, so that the elastic contact members can contact with the grill member according to the open/close operation of the louver
25 blades.

25. The outdoor unit of claim 24, wherein, when the louver blades are closed, the elastic contact members do not contact with the grill member, and when the louver blades are opened, the elastic contact members contact with the grill member.

5

26. A built-in type outdoor unit for an air conditioner, comprising:

a louver frame being fixedly installed on a rectangular space inner wall formed on an outer wall of a building, being divided into a suction area and a discharge area, including a plurality of louver blades in each area, and sucking and discharging air through gaps between the louver blades; and

10

an outdoor unit casing fixedly installed to contact with the louver frame, formed in a rectangular parallelepiped shape having its one side facing the suction area and the discharge area of the louver frame opened and its top surface, bottom surface and three sides closed, and divided into a suction unit and a discharge unit corresponding to the suction area and the discharge area of the louver frame,

15

wherein the louver blades have wave-shaped curved sections.

27. The outdoor unit of claim 26, wherein the louver blades of the discharge area have wave-shaped curved sections whose ends are upwardly inclined in order to discharge air in the upward direction.

20

28. The outdoor unit of claim 26, wherein the louver blades of the suction area have wave-shaped curved sections whose ends are downwardly inclined in order to suck air from their lower portions.

25

29. The outdoor unit of one of claims 26 to 28, wherein in an open state, a

close state and/or an open angle of the louver blades are controlled.

30. The outdoor unit of claim 29, wherein a grill member for preventing external alien substances is further installed between the louver frame and the outdoor unit casing, and the louver blades further comprise elastic contact members in the outdoor unit casing area, so that the elastic contact members can contact with the grill member according to the open/close operation of the louver blades.

31. The outdoor unit of claim 30, wherein, when the louver blades are closed, the elastic contact members do not contact with the grill member, and when the louver blades are opened, the elastic contact members contact with the grill member.

32. A built-in type outdoor unit for an air conditioner, comprising:
a louver frame being fixedly installed on a rectangular space inner wall formed on an outer wall of a building, being divided into a suction area and a discharge area, including a plurality of louver blades which can be opened/closed in each area, and sucking and discharging air through gaps between the opened louver blades;

an outdoor unit casing fixedly installed to contact with the louver frame, formed in a rectangular parallelepiped shape having its one side facing the suction area and the discharge area of the louver frame opened and its top surface, bottom surface and three sides closed, and divided into a suction unit and a discharge unit corresponding to the suction area and the discharge area of the louver frame; and

a grill member installed between the louver frame and the outdoor unit

casing, for preventing external alien substances,

wherein the louver blades further comprise elastic contact members in the outdoor unit casing area, so that the elastic contact members can contact with the grill member according to the open/close operation of the louver blades.

5

33. The outdoor unit of claim 32, wherein, when the louver blades are closed, the elastic contact members do not contact with the grill member, and when the louver blades are opened, the elastic contact members contact with the grill member.

10

1/15
FIG. 1

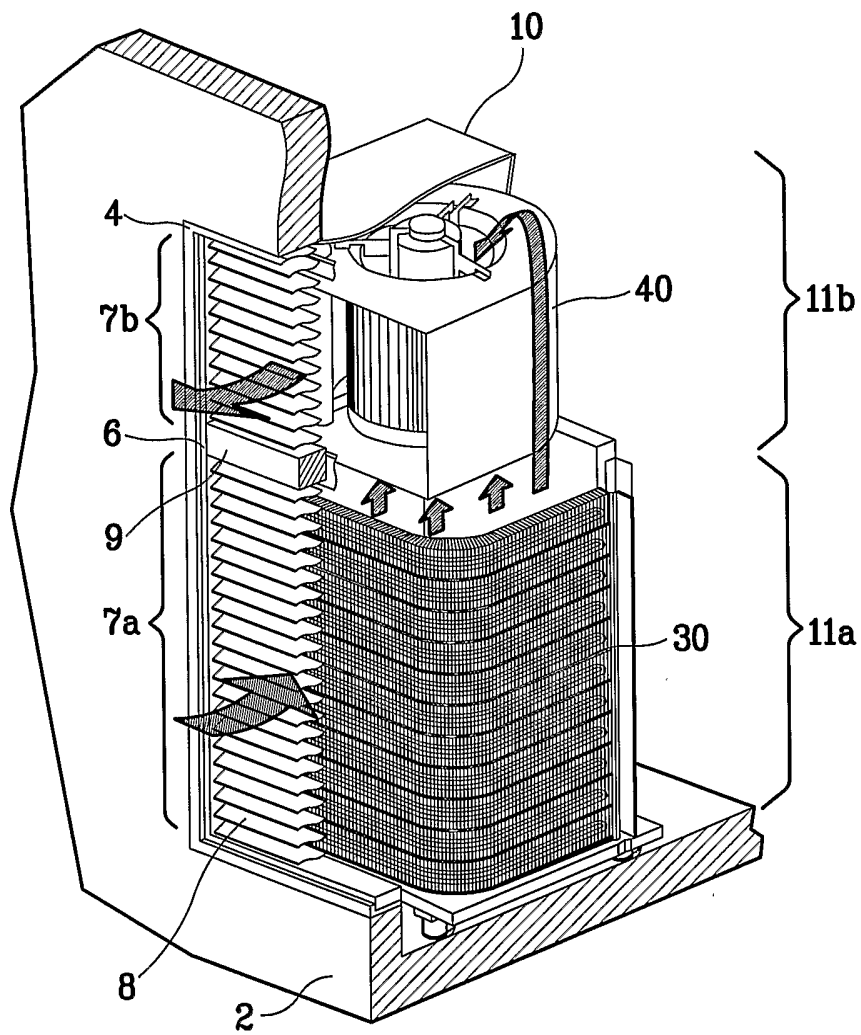

2/15
FIG. 2

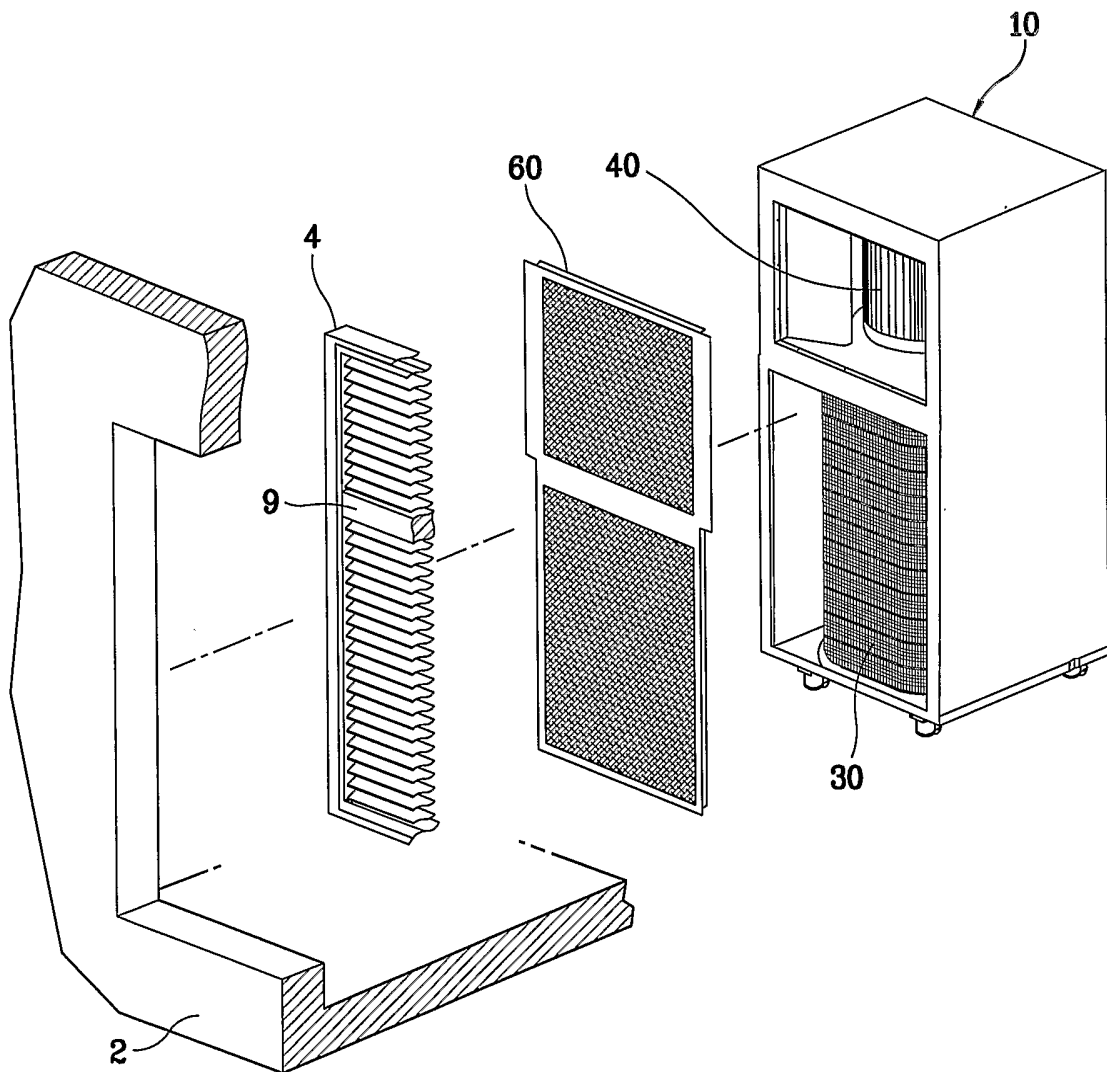

3/15
FIG. 3

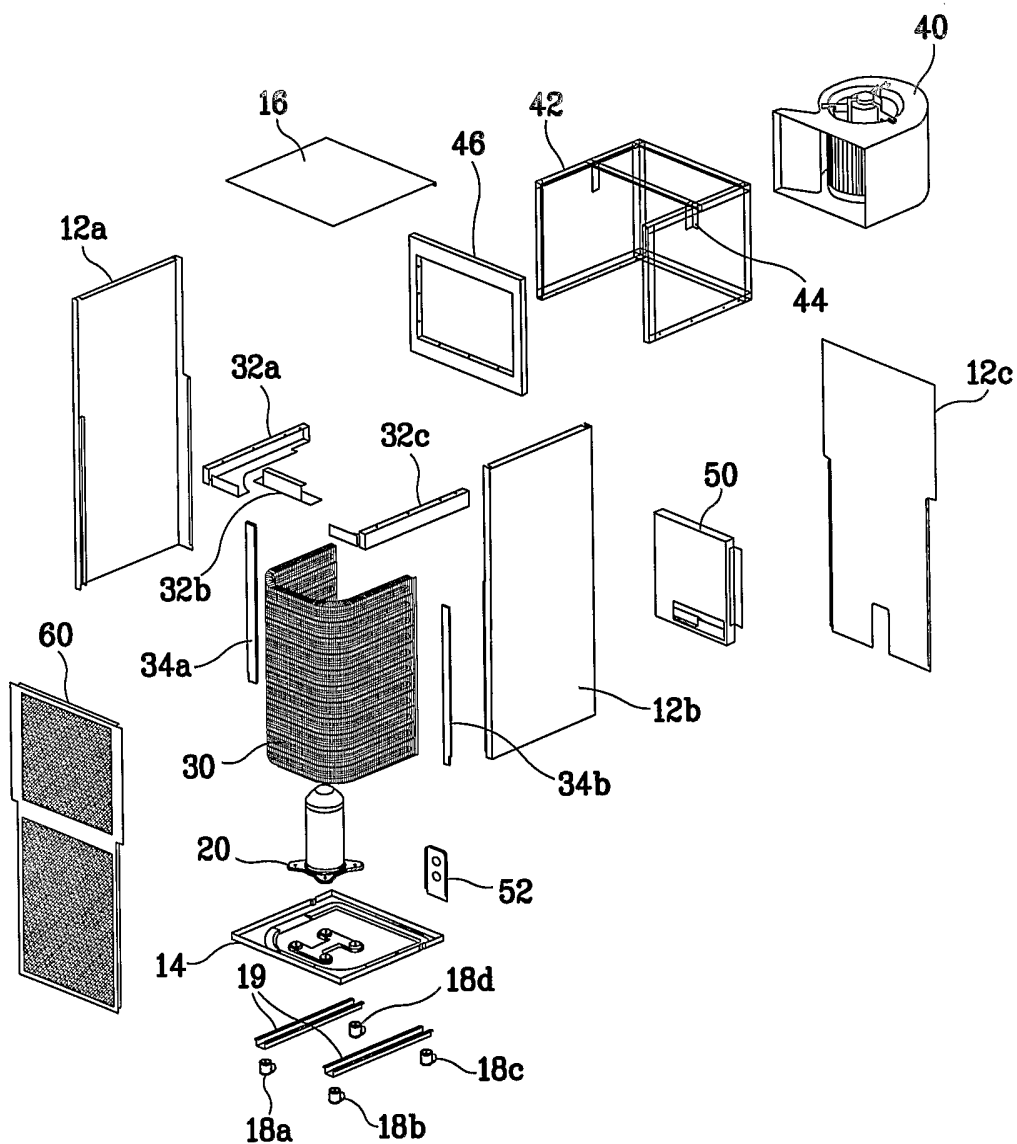

4/15
FIG. 4A

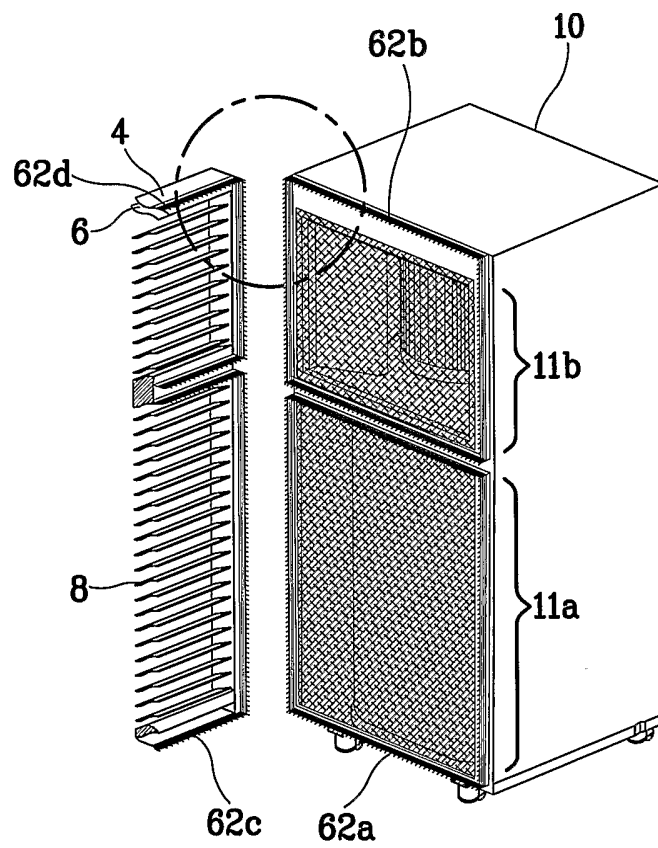

5/15

FIG. 4B

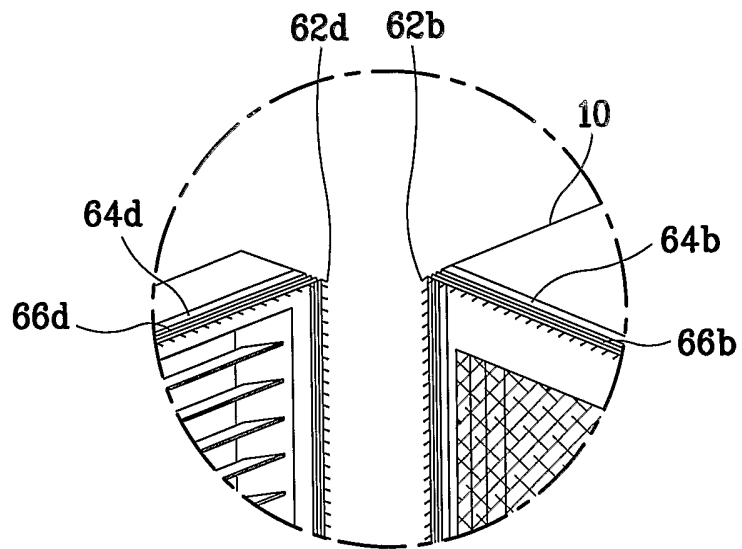
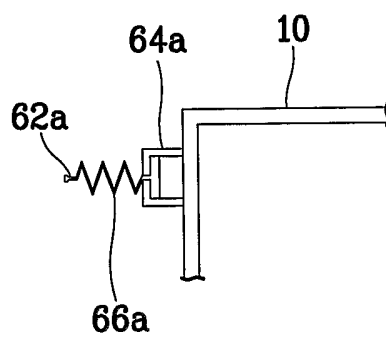
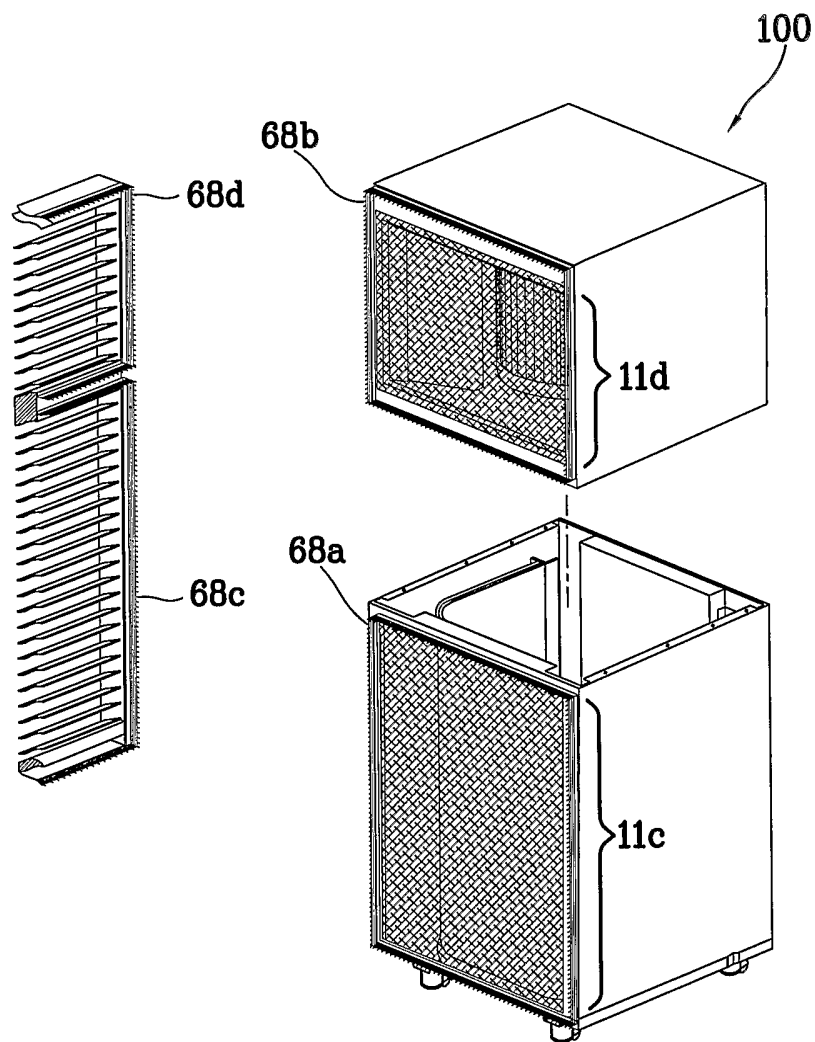

FIG. 4C



6/15
FIG. 4D



7/15
FIG. 4E

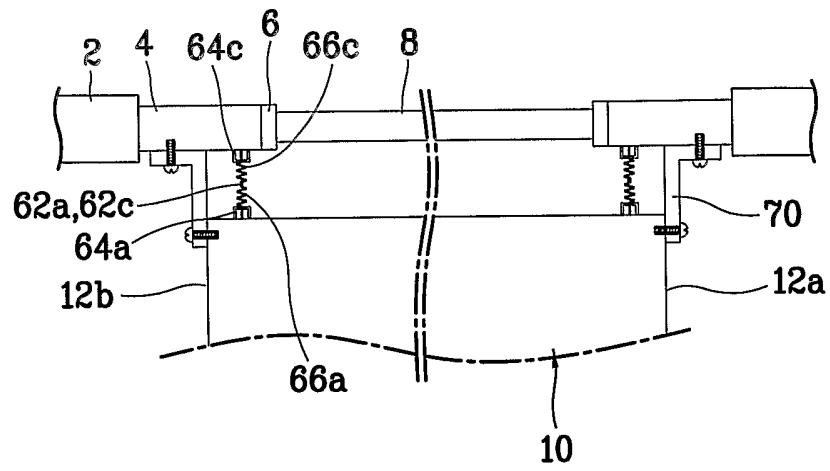

8/15
FIG. 5A

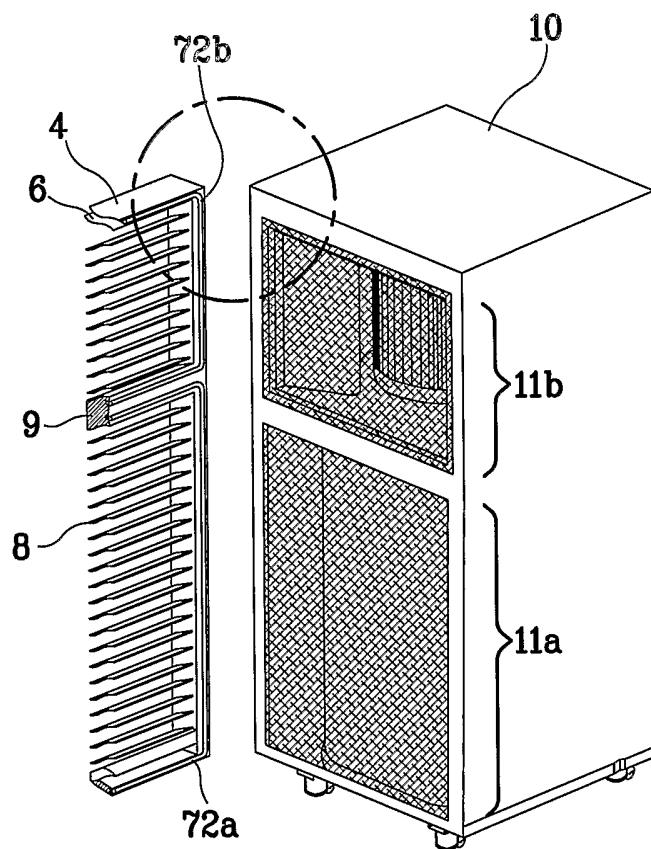

9/15
FIG. 5B

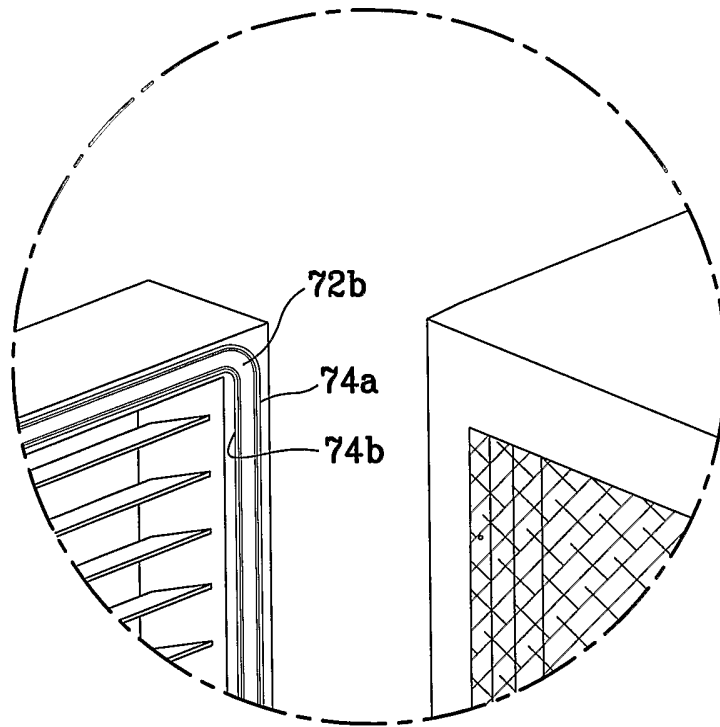
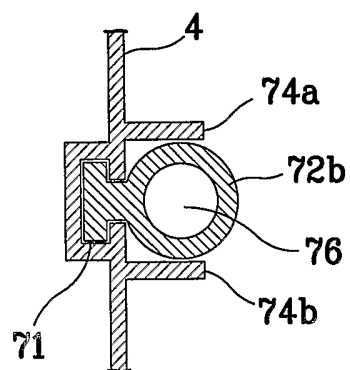
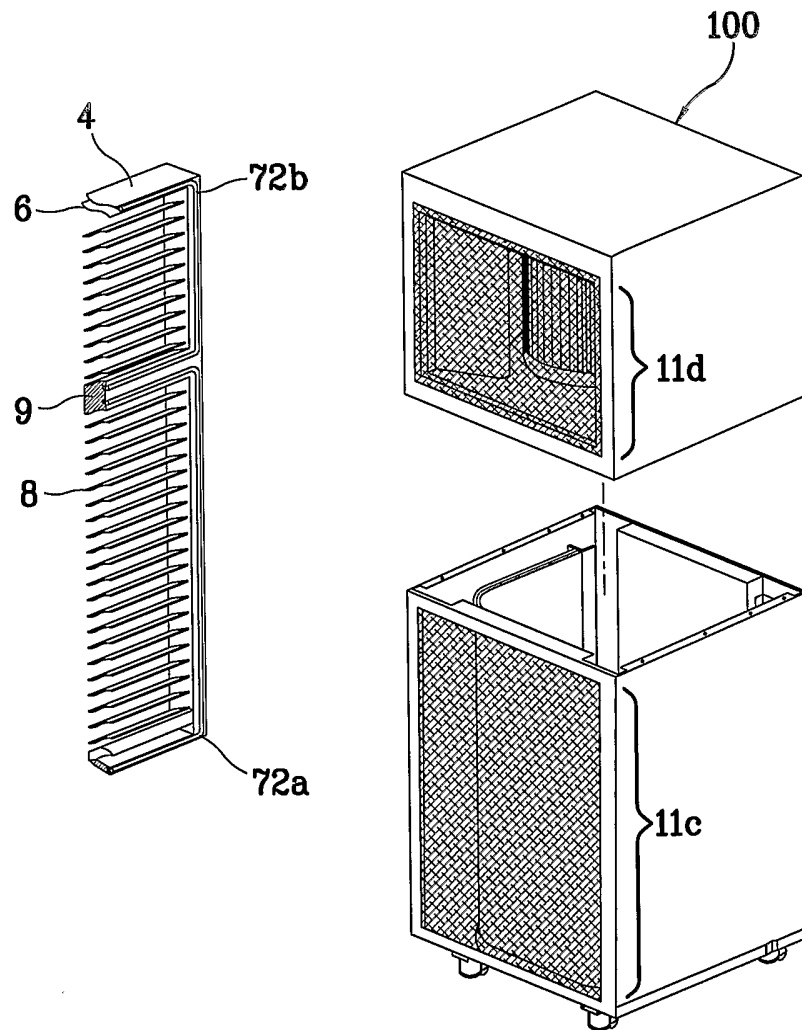

FIG. 5C



10/15
FIG. 5D



11/15
FIG. 5E

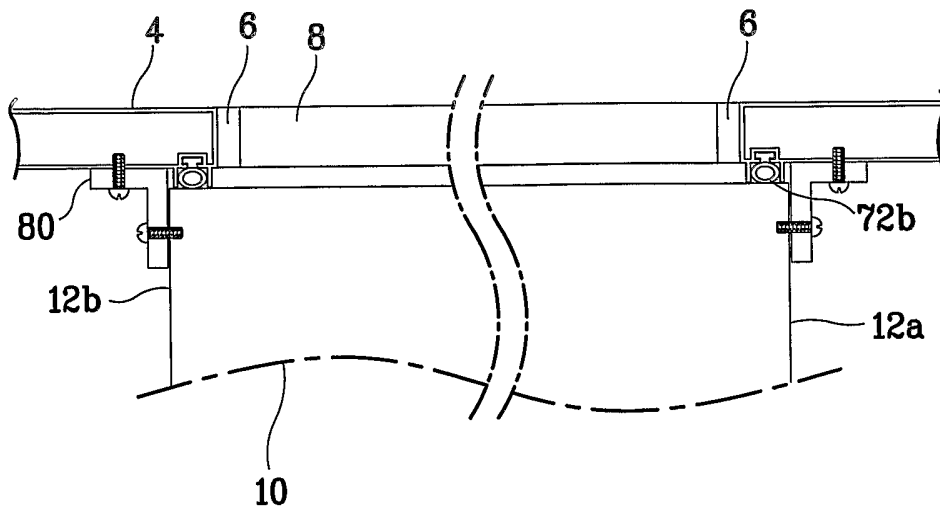
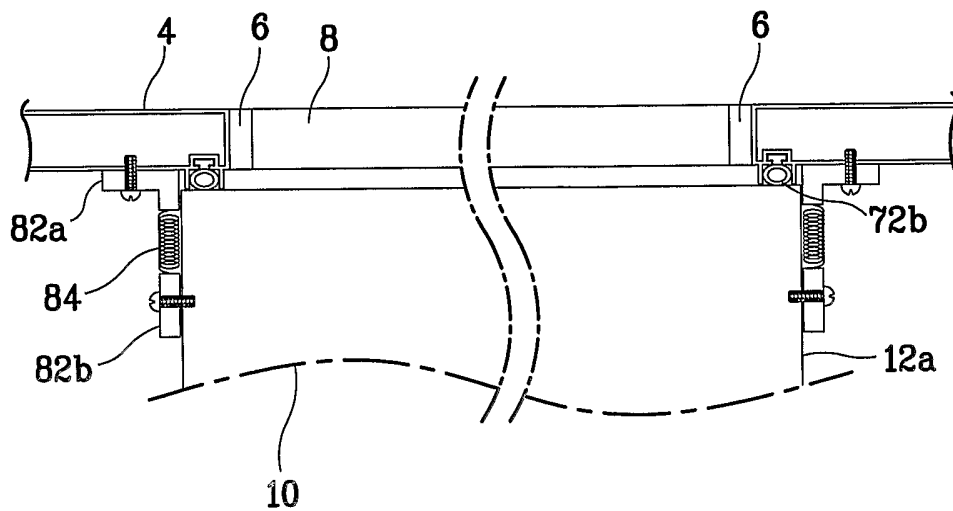
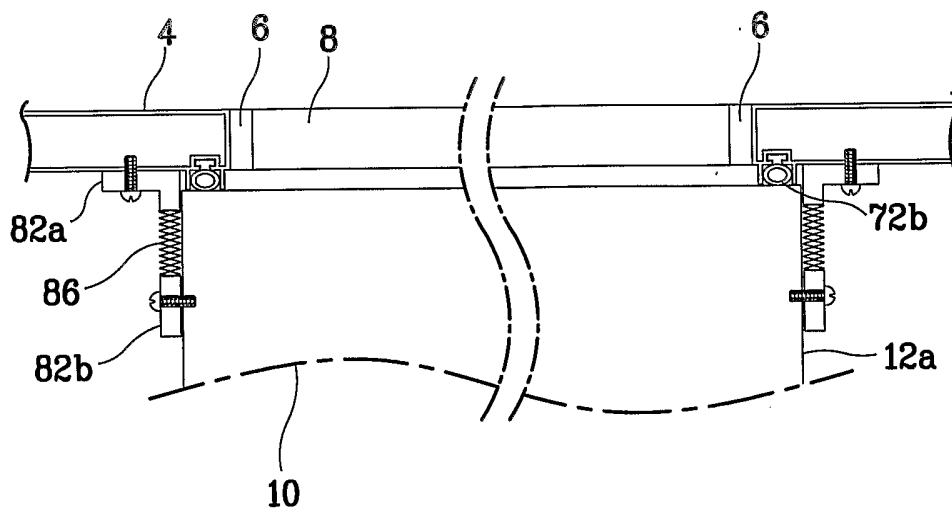

FIG. 5F



12/15
FIG. 5G



13/15
FIG. 6

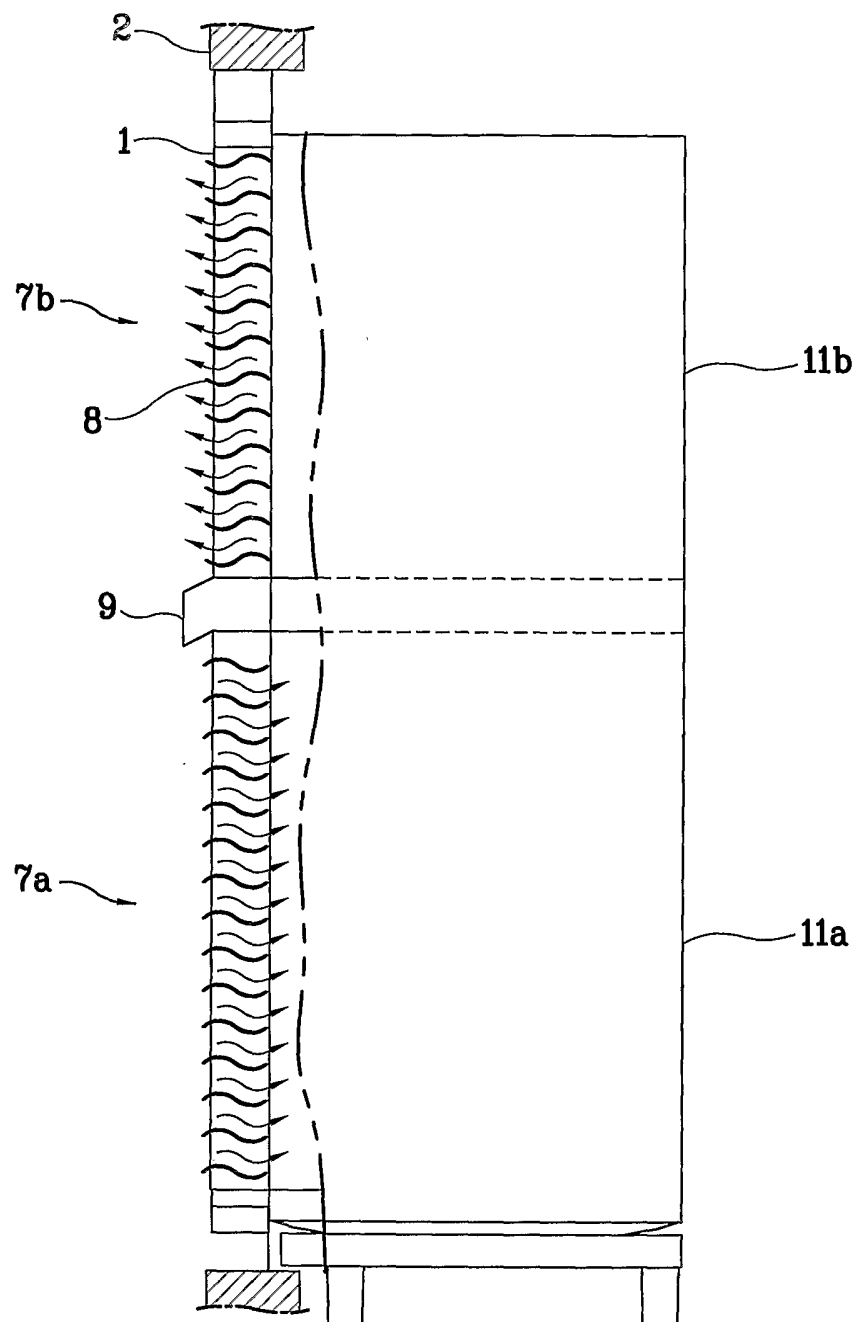

14/15

FIG. 7A

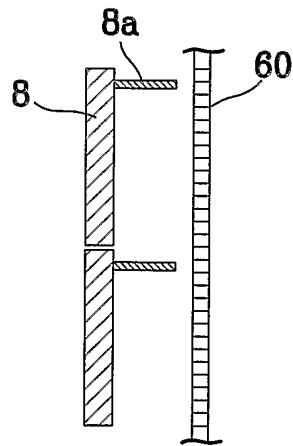
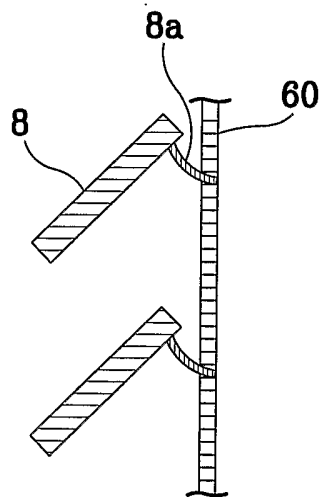
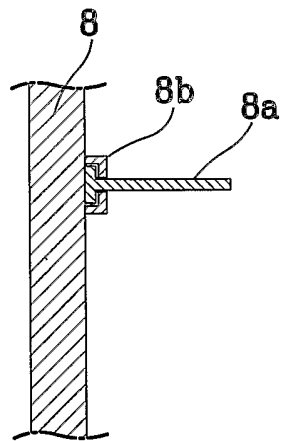

FIG. 7B



15/15
FIG. 7C



INTERNATIONAL SEARCH REPORT

International application No.
PCT/KR 03/01123-0

CLASSIFICATION OF SUBJECT MATTER		
IPC ⁷ : F24F 1/00, 13/08		
According to International Patent Classification (IPC) or to both national classification and IPC		
B. FIELDS SEARCHED		
Minimum documentation searched (classification system followed by classification symbols)		
IPC ⁷ : F24F		
Documentation searched other than minimum documentation to the extent that such documents are included in the fields searched		
Electronic data base consulted during the international search (name of data base and, where practicable, search terms used)		
EpoDoc PAJ		
C. DOCUMENTS CONSIDERED TO BE RELEVANT		
Category	Citation of document, with indication, where appropriate, of the relevant passages	Relevant to claim No.
X	JP 08 135997 A (SANYO ELECTRIC) 31 May 1996 (31.05.1996) <i>figures 1-3; abstract.</i>	1
A		2-25, 29-33
X	JP 11 300710 A (SANYO ELECTRIC) 2 November 1999 (02.11.1999) <i>figure 1; abstract.</i>	1
A		2-25, 29-33
X	GB 551023 A (HURDEN) 4 February 1943 (04.02.1943) <i>the whole document.</i>	26-28
A		29-31

<input type="checkbox"/> Further documents are listed in the continuation of Box C. <input checked="" type="checkbox"/> See patent family annex.		
* Special categories of cited documents: „A“ document defining the general state of the art which is not considered to be of particular relevance „E“ earlier application or patent but published on or after the international filing date „L“ document which may throw doubts on priority claim(s) or which is cited to establish the publication date of another citation or other special reason (as specified) „O“ document referring to an oral disclosure, use, exhibition or other means „P“ document published prior to the international filing date but later than the priority date claimed „T“ later document published after the international filing date or priority date and not in conflict with the application but cited to understand the principle or theory underlying the invention „X“ document of particular relevance; the claimed invention cannot be considered novel or cannot be considered to involve an inventive step when the document is taken alone „Y“ document of particular relevance; the claimed invention cannot be considered to involve an inventive step when the document is combined with one or more other such documents, such combination being obvious to a person skilled in the art „&“ document member of the same patent family		
Date of the actual completion of the international search		Date of mailing of the international search report
12 March 2004 (12.03.2004)		17 May 2004 (17.05.2004)
Name and mailing address of the ISA/AT Austrian Patent Office Dresdner Straße 87, A-1200 Vienna Facsimile No. 1/53424/535		Authorized officer LOSENICKY G. Telephone No. 1/53424/372

INTERNATIONAL SEARCH REPORT

Information on patent family members

International application No.

PCT/KR 03/01123-0

Patent document cited in search report			Publication date	Patent family member(s)	Publication date
GB	A	551023	1943-02-04	none	
JP	A	8135997A 2		none	
JP	A	11300710 A2		none	