

Sept. 12, 1967

K. SALNA

3,341,041

MATERIAL HANDLING ATTACHMENT

Filed Dec. 8, 1965

2 Sheets-Sheet 1

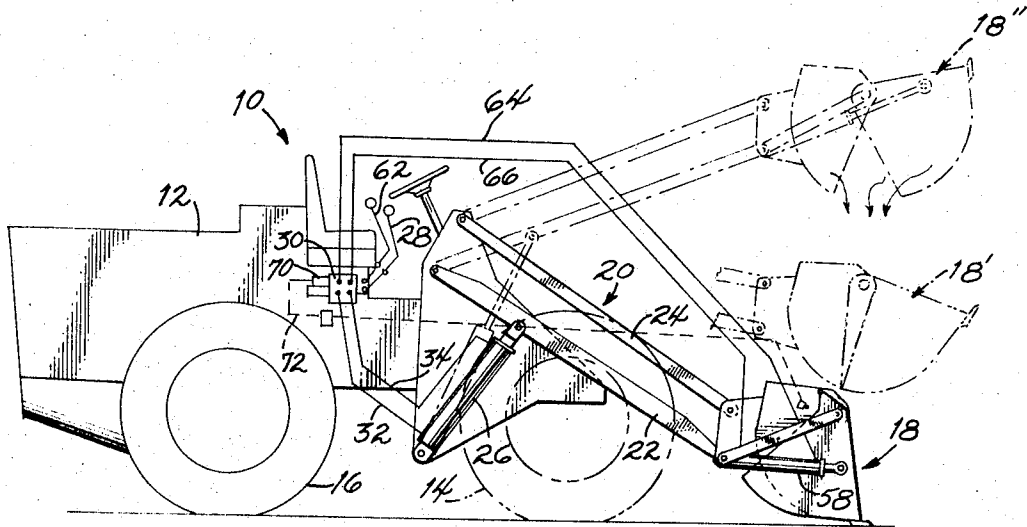

FIG. 1

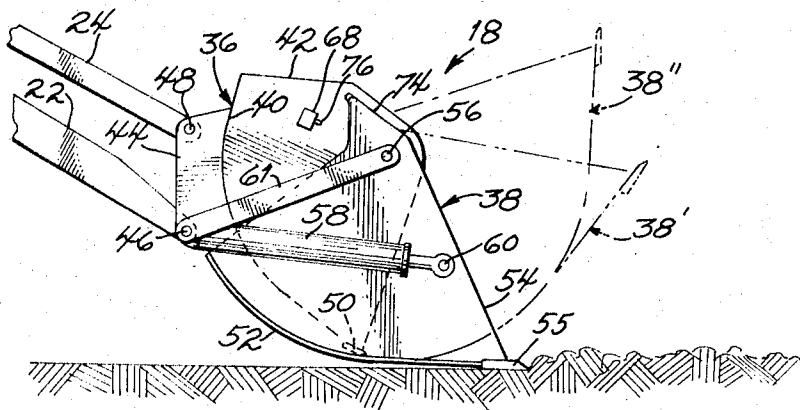

FIG. 2

INVENTOR  
KARL SALNA

BY

*Richard E. Backus*

ATT'Y.

Sept. 12, 1967

K. SALNA

3,341,041

MATERIAL HANDLING ATTACHMENT

Filed Dec. 8, 1965

2 Sheets-Sheet 2

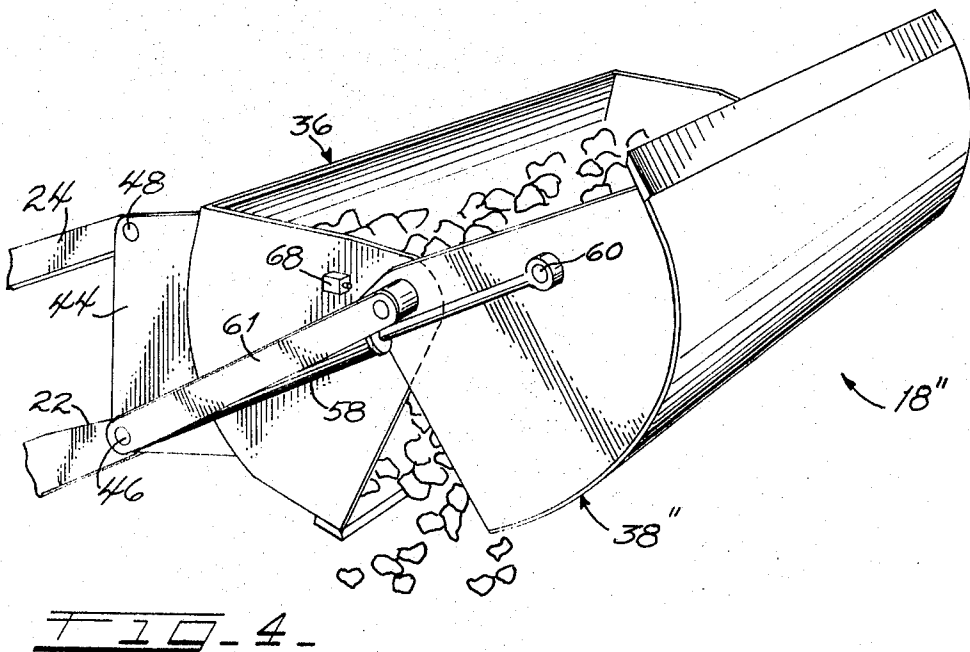
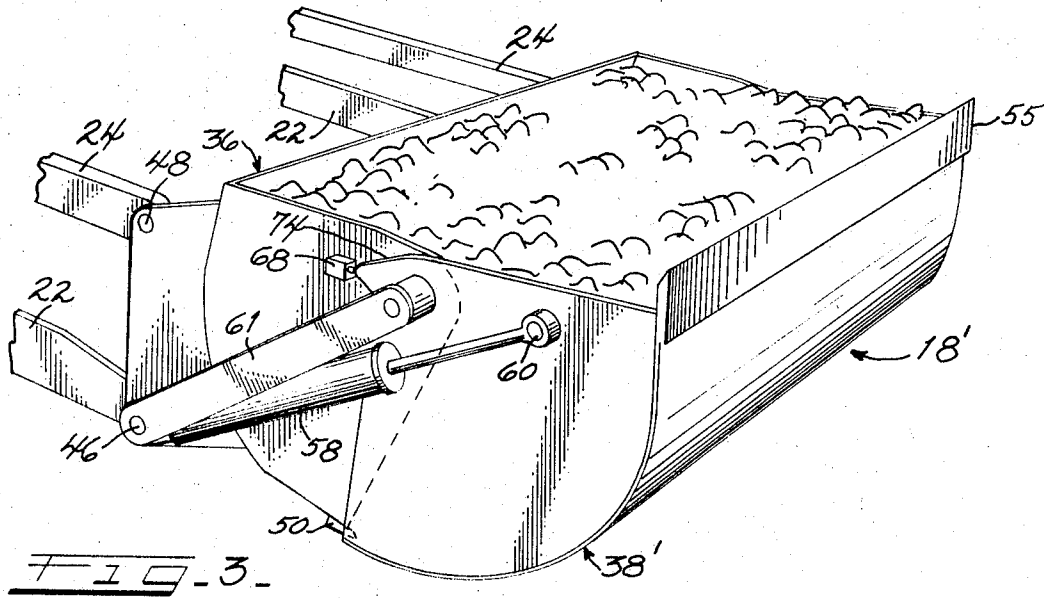

INVENTOR  
KARL SALNA

BY

Richard E. Barkus ATT'Y.

3,341,041

**MATERIAL HANDLING ATTACHMENT**  
 Karl Salna, Mundelein, Ill., assignor to International  
 Harvester Company, a corporation of Delaware  
 Filed Dec. 8, 1965, Ser. No. 512,476  
 4 Claims. (Cl. 214-145)

**ABSTRACT OF THE DISCLOSURE**

A variable volume material handling bucket having a front section pivoting backward on a rear section to a digging position, then forward to a carrying position, and then further forward to a dumping position, with a control to automatically terminate pivoting in the carrying position following a digging operation.

*Summary of the invention*

This invention relates to a material handling bucket for tractor loaders and more particularly relates to a variable volume bucket for tractor loaders affording increased dumping height, self-cleaning ability, more efficient cutting action, a greater range of bucket uses, and simplified control features.

Conventional tractor loader vehicles may be provided with a variety of buckets to handle disparate material handling functions, such as front-end loading, clam-shell operation, leveling, grading, and bulldozing. Alternatively, a two-section bucket embodying a front section pivoting relative to a rear section may be provided to handle all of these functions through selective angular adjustment of the two bucket sections.

Conventional buckets have attendant disadvantages which limit their usefulness. Thus, a heavy and expensive rocker arm linkage is required to pivot the bucket sections relative to the tractor boom. These bucket designs also have a fixed bucket capacity for loading purposes; it is impossible to selectively vary the volume of the bucket to meet the requirements in a particular material. Also, conventional bucket blades have an objectionable cutting action while working in material. This cutting action is a shearing action with the blade moving into the material at an oblique angle to the plane of the blade. This limits the length of teeth which may be attached to the blade and also increases the force required to operate the bucket in the material. A more desirable cutting action would exist where the blade edge moves directly into the material with a minimum of shearing movement.

Accordingly, it is an object of this invention to provide a material handling attachment for a tractor loader which incorporates a two-section bucket providing a variable volume capacity.

It is another object of this invention to provide a material handling attachment for a tractor loader in which the attachment incorporates a bucket having a front section pivoting relative to a rear section whereby the cutting action of the bucket is improved in that shearing movement of a blade mounted on the front section is substantially reduced.

Still another object of this invention is to provide a material handling attachment for a tractor loader in which a two-section variable volume bucket is mounted on a floating linkage boom arrangement whereby dumping is achieved by pivoting the front section away from the rear section, thus achieving an increased dumping height as compared to present loader attachments while eliminating the need for a heavy and expensive rocker arm assembly.

Another object of this invention is to provide a material handling attachment for a tractor loader comprising a variable volume bucket with front and rear sections operable between digging, carrying and dumping positions and in which means are employed to automatically terminate operation of the sections upon their reaching the carrying position so that the operator may quickly and easily manipulate the loader controls for bringing the bucket to the dumping position.

Yet another object is to provide a material handling attachment for a loader vehicle comprising a bucket having front and rear sections pivoting about a common axis and in which dumping is achieved by pivoting the front section ahead of the rear section.

*Description of the drawings*

Other objects and advantages of the present invention will become apparent to those skilled in the art when the following specifications are read in connection with the accompanying drawings, wherein:

FIGURE 1 is a side elevation view of a tractor loader vehicle incorporating a preferred form of the material handling attachment of the present invention with a two-section bucket attachment illustrated serially in digging, carrying, and dumping positions and with a superimposed schematic diagram of the automatic bucket positioning control as contemplated herein;

FIGURE 2 is an enlarged side elevation view of the attachment of FIGURE 1 showing the two-section construction with the front section pivoting serially through three positions relative to the rear section;

FIGURE 3 is a perspective view of the attachment of FIGURE 1 illustrating the carry position with engagement of the control switch for terminating operation of the front section with respect to the rear section; and

FIGURE 4 is a perspective view similar to FIGURE 3 illustrating the attachment in the dumping position wherein the material is emptied through the space resulting after pivoting the front section forwardly of the rear section.

*Description of the preferred embodiment*

Referring now to the drawings, and particularly FIGURE 1, an exemplary tractor loader vehicle is indicated generally at 10. The loader vehicle 10 comprises a frame supported by front and rear pairs of wheels 14 and 16, respectively. A material handling bucket attachment 18 is mounted on the forward end of frame 12 for vertical swinging movement by means of a boom shown generally at 20. With the bucket attachment 18 in the digging position as shown in the full line illustration of FIGURE 1 the boom 20 is cradled between the front pair of wheels 14.

The boom 20 comprises a parallelogram linkage construction whereby the bucket 18 is raised and lowered with a substantially constant attitude relative to the vehicle. A pair of transversely spaced-apart lower boom arms 22 are each pivotally connected at one end to frame 12 and at their other end to bucket 18. Similarly, a pair of transversely spaced-apart upper boom arms 24 are each pivotally connected at one end to frame 12 and at their other end to bucket 18. Vertical pivotal movement of boom 12 is effected through operation of a pair of extensible hydraulic rams 26 which are each pivotally connected at their head end to frame 12 and at their rod end to arms 22. Selective extension and retraction of rams 26 is produced by manipulation of control handle 28 which in turn operates a conventional open-center control valve 30 to direct fluid under pressure from a hydraulic pump (not shown) into a selected one of the fluid conduits 32 or 34 leading respectively to the head and rod ends of the rams 26.

Turning now to FIGURE 2 the bucket attachment 18 is shown in greater detail. The attachment comprises a two section bucket providing a variable volume capacity. A rear section 36 is pivotally mounted to the free ends of boom arms 22 and 24 and a front section 38 is in turn pivotally mounted to the top of the rear section. The rear section opens forwardly in a scoop-shaped configuration defined by an arcuate rear wall 40 rigidly secured between a pair of side walls 42. A pair of rearwardly extending brackets 44 are secured to the rear wall. Pins 46 and 48 provide a pivotal connection between boom arms 22 and 24, respectively, and the brackets 44. A forwardly directed blade 50 is mounted on the leading edge of the rear wall 40.

The front section 38 comprises a bottom wall 52 underlying rear wall 40 and rigidly secured between a pair of side walls 54. The side walls 54 are pivotally mounted to the upper ends of side walls 42 by means of pins 56. Side walls 54 are in a close fitting, overlapping relationship with side walls 42 of the rear section, while the rearward arcuate portion of bottom wall 52 is in sliding contact with the blade 50. Pivotal movement of the front section relative to the rear section will automatically clean adhering material from the inner surfaces of the walls on the front section.

The front section thus defines a substantially U-shaped member which subtends the rear section and pivots in relationship thereto between the digging position 38, the carrying position 38', and the dumping position 38''.

A cutting blade 55 is preferably secured to the leading edge of the bottom wall 52; conventional bucket teeth (not shown) may also be attached to the leading edge of the bottom wall 52.

Pivotal movement of the front section 54 is effected through operation of a pair of extensible hydraulic rams 58. Each of the rams 58 is pivotally connected at its head end to a respective bracket 44 by means of pin 46 and at its rod end to a pin 60 mounted on the side wall 54 adjacent its leading edge. A brace member 61 is secured on either side of the bucket 18 and extends between the outer ends of pins 46 and 56.

The control circuit for operating the rams 58 is illustrated schematically in FIGURE 1. Manipulation of control handle 62 operates a spool of control valve 30 in a well-known manner to direct hydraulic fluid under pressure from a hydraulic pump (not shown) into a selected one of the fluid conduits 64 and 66. Conduits 64 direct fluid into the rod end of ram 58 for retraction thereof while conduit 66 directs fluid into the head end for extension of the ram.

Forward pivotal movement of the front section 54 about pins 56 produces a more direct cutting action for the blade 53 as compared to conventional buckets. With a conventional bucket the front section would pivot about pins carried by the ends of the boom arms, thereby creating an objectionable scraping or shearing action of the blade against the material. In applicant's invention the pivot center is much higher with respect to the blade, thus permitting the blade to penetrate the material directly with a minimum of shearing action. This affords faster cutting of material and also requires less power for the digging operation as compared to conventional buckets. Furthermore, longer teeth may be mounted on the leading edge of blade 53 with a consequent increase in ability to dig compacted material.

The invention contemplates an automatic feature to terminate pivoting of the front section relative to the rear section when the front section reaches the carry position 38'. This automatic feature provides a simplified means to enable the vehicle operator to manipulate the controls during a digging operation so that the bucket accurately achieves its desired volume capacity in the carry position.

To provide this means a conventional cam operated normally-open microswitch 68 is provided to energize a

detent mechanism 70 through an electrical circuit 72. The microswitch 68 may be mounted at any convenient position on the bucket and is preferably shown mounted on the upper margin of the right side wall 42. A camming surface 74 is formed integral with the upper portion of the front section side wall 54 and engages the plunger 76 of microswitch 68, as illustrated in FIGURE 3. Microswitch 68 in turn completes the circuit 72 from a source of electrical power (not shown) to energize a conventional solenoid for releasing the detent mechanism 70. The detent mechanism 70 is broadly conventional and preferably is of the type disclosed in application Serial No. 461,866, filed June 7, 1965, by Joseph H. Konefes, and assigned to The Frank G. Hough Co.

In operation, assuming that the boom 20 is lowered and the bucket is in the position indicated at 18 for entry into the material, the operator will manipulate handle 62 to position the spool of valve 30 for directing fluid into conduit 66 for extension of rams 58. Detent mechanism 70 will operate to releasably hold the spool of valve 30 in this position. As the ram extends, the front section 38 pivots forward and progressively fills the bucket with material until it reaches position 38'. In this position microswitch 68 is closed by cam 74, thereby energizing circuit 72 for releasing detent 70. The spool of valve 30 will now return to its open-center position, thus terminating fluid flow through conduit 66 and stopping the forward pivotal movement of the front section. With the bucket now automatically filled with material at its maximum capacity the operator will manipulate control handle 62 for raising the boom 20 and lifting the bucket to the carry position 18', and sequentially to the dump position 18''. In the dump position the operator will manipulate the control handle 62 to position the spool of valve 30 for directing fluid through conduit 66 for further extension of rams 58. The front section 38 will now pivot forward of the rear section, thus allowing the material to drop from the bucket as illustrated in FIGURE 4. As best shown in FIGURES 1 and 4 it is apparent that no part of the bucket moves downwardly during the dumping operation so that material can be loaded over high elevations, such as adjacent truck-trailer beds.

It will be understood that various changes in the details, steps and arrangement of parts, which have been described and illustrated in order to explain the nature of the invention, may be made by those skilled in the art within the principle and scope of the invention as expressed in the appended claims.

What is claimed is:

1. A variable volume material-handling attachment for use with a tractor loader vehicle having a boom, the attachment including the combination of: a bucket having a back section mounted on the boom and a front section mounted on the upper margin of the back section for pivotal movement about a transverse axis between digging, carrying and dumping positions; the back section having a rear wall for scooping and carrying the material; the front section having a bottom wall adapted to pivot under the rear wall whereby the volume of the bucket is selectively varied between the digging and carrying positions, the front section further being adapted to pivot forward of the rear wall whereby the material is dumped from the bucket; and, means to selectively pivot the front section between said positions including an extensible hydraulic ram connected between the front section and the rear section, a source of fluid under pressure, control means to selectively direct the fluid to the ram for extension and retraction thereof, and means to terminate operation of the control means responsive to movement of the front section to the carrying position.

2. A variable volume material-handling attachment for use with a tractor loader vehicle having a boom, the attachment including the combination of: a bucket having a back section mounted on the boom and a front section mounted on the upper margin of the back section for

5

pivotal movement about a transverse axis between digging, carrying, and dumping positions; the back section having a rear wall for scooping and carrying the material; the front section having a bottom wall adapted to pivot under the rear wall whereby the volume of the bucket is selectively varied between the digging and carrying positions, the front section further being adapted to pivot forward of the rear wall whereby the material is dumped from the bucket; and, means to selectively pivot the front section between said positions including at least one extensible hydraulic ram connected between the front section and the rear section whereby extension of the ram pivots the front section forward and retraction of the ram pivots the front section backward; a source of fluid under pressure; control means having a valve normally biased to a neutral position and selectively movable between a first operating position to direct the fluid to the ram for extension thereof and a second operating position to direct the fluid to the ram for retraction thereof; detent means to releasably hold the valve in the first operating position; and, means to release the detent means responsive to movement of the front section to the carrying position whereby the valve is biased to the neutral position and operation of the ram is terminated.

3. A variable volume material-handling attachment for use with a tractor loader vehicle having a boom, the attachment including the combination of: a bucket having a back section mounted on the boom and a front section mounted on the upper margin of the back section for pivotal movement about a transverse axis between digging, carrying, and dumping positions; the back section having a rear wall for scooping and carrying the material; the front section having a bottom wall adapted to pivot under the rear wall whereby the volume of the bucket is selectively varied between the digging and carrying positions, the front section further being adapted to pivot forward of the rear wall whereby the material is dumped from the bucket; means to selectively pivot the front section between said positions; said back section includes a first pair of transversely spaced-apart side wall supporting the rear wall and mounted on the boom; the front section includes a second pair of transversely spaced-apart side walls enclosing the first pair of side walls and

6

supporting the bottom wall; and the back section further includes a blade mounted on the front edge of the rear wall and in contact with the top surface of the bottom wall whereby pivotal movement of the front section relative to the back section removes adhering material from the bottom wall.

4. A variable volume material-handling attachment for use with a tractor loader vehicle having a boom, the attachment including the combination of: a bucket having a back section mounted on the boom and a front section mounted on the upper margin of the back section for pivotal movement about a transverse axis between digging, carrying, and dumping positions; the back section having a rear wall for scooping and carrying the material; the front section having a bottom wall adapted to pivot under the rear wall whereby the volume of the bucket is selectively varied between the digging and carrying positions, the front section further being adapted to pivot forward of the rear wall whereby the material is dumped from the bucket; means to selectively pivot the front section between said positions; the back section includes a first pair of transversely spaced-apart side walls supporting the rear wall and mounted on the boom; the front section includes a second pair of transversely spaced-apart side walls enclosing the first pair of side walls and supporting the bottom wall; the means to pivot the front section includes a pair of extensible hydraulic rams, each of the rams being mounted at its head end to a first side wall and at its rod end to a respective second side wall; and, a pair of brace members, each of the brace members being connected at one end to the head end of a respective ram and at its other end to the bucket at the transverse axis.

#### References Cited

##### UNITED STATES PATENTS

2,280,439	4/1942	McLean.	
2,812,595	11/1957	Drott	37—117.5
3,070,246	12/1962	Johnson et al.	214—146
3,252,606	5/1966	Pryor	214—767

HUGO O. SCHULZ, *Primary Examiner.*