

Nov. 17, 1925.

1,561,673

C. E. ULERY ET AL

CLOCK ARBOR OR SHAFT

Filed April 3, 1924

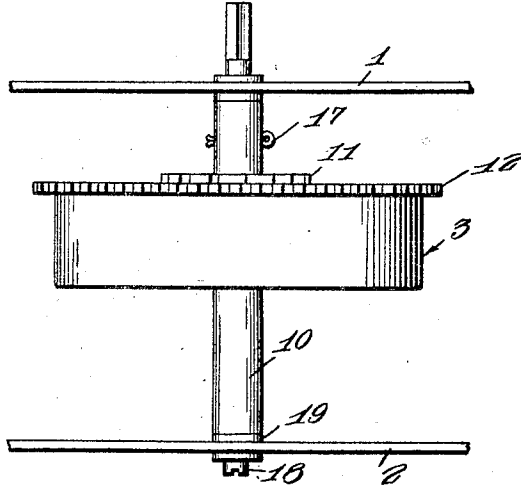
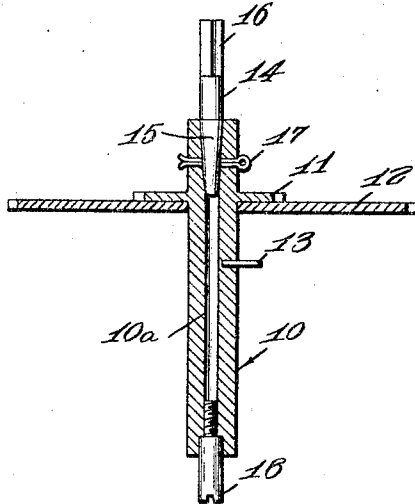

Fig. 1.



*Fig. 2. C. E. Ulery AND
F. C. Fitch*

Inventors

334 *C. Snow & Co.*
Attorneys

UNITED STATES PATENT OFFICE.

CLARENCE EVERETT ULERY AND FRANK CARPENTER FITCH, OF TERRELL, TEXAS.

CLOCK ARBOR OR SHAFT.

Application filed April 3, 1924. Serial No. 704,000.

To all whom it may concern:

Be it known that we, CLARENCE EVERETT ULERY and FRANK C. FITCH, citizens of the United States, residing at Terrell, in the county of Kaufman and State of Texas, have invented a new and useful Clock Arbor or Shaft, of which the following is a specification.

This invention relates to arbors or shafts for main and striking springs of clocks.

The primary object of the invention is to provide an arbor of this class composed of separable sections, so constructed and connected that the springs mounted thereon may be quickly removed and replaced by another without disturbing the frame or any other part.

With the foregoing and other objects in view which will appear as the description proceeds, the invention resides in the combination and arrangement of parts and in the details of construction hereinafter described and claimed, it being understood that changes in the precise embodiment of the invention herein disclosed may be made within the scope of what is claimed without departing from the spirit of the invention.

In the accompanying drawings—

Figure 1 represents a side elevation of a clock arbor embodying this invention,

Fig. 2 is a vertical section thereof.

In the embodiment illustrated 1 and 2 represent respectively the front and rear faces of a clock in which is mounted the spring arbor or shaft 10, the spring 3 being attached to said arbor at its inner end by a pin shown at 13 in Fig. 2.

The arbor 10 is constructed of a tubular main or body portion 10^a with the bore thereof flared at its upper end to receive a tapered section 14 which detachably engages with the flared portion of said bore. The tapered section or pin 14 has its pointed end 15 inserted in one end of the bore of section 10^a which is correspondingly tapered to receive it and is secured therein by a cotter pin 17. The outer end of the pin 14 is made polygonal to receive the winding key.

A screw 18 is engaged with the other end of the arbor section 10^a and is designed to hold this end of the arbor in a bushing 19 carried by the wall 2. The upper end of the section 10^a has a ratchet wheel 11 adjacent

the lower face of which is mounted the main gear 12. This main driving gear 12 turns freely on the arbor 10^a as usual in clocks of this character while the ratchet 11 operates to wind the spring.

In the use of this attachment when it is desired to remove the spring 3 for repairs or other purposes the cotter pin 17 is first withdrawn and then the screw 18 is removed. To separate sections 14 and 10^a a rod or other punch is forcibly inserted through the open end of section 10^a into the bore thereof and given a light rap which will force the tapered section 14 out permitting the arbor and spring to be removed without interfering with any other parts of the clock.

It is of course understood that the arbor herein shown and described may be used in connection with either the main driving spring or the striking spring or both and permits the quick replacement of a broken or set spring, without disturbing any of the other parts.

The tapered pin section 14 is telescopically engaged with the section 10^a, the pointed end 15 of said section 14 fitting in a seat in the end of section 10^a which is correspondingly tapered to receive it, the cotter pin 17 passing through both sections as is shown clearly in Fig. 2.

What is claimed is:—

1. An arbor of the class described comprising a tubular section, another section telescopically engaging one end of said tubular section and detachably connected therewith and a screw threaded in the other end of said tubular section to form a bearing extension for the arbor.

2. An arbor of the class described comprising a tubular section having a bore flared at one end and a removable screw at the other end, a tapered pin section for insertion in the tapered flared end of said bore of the other section, and a cotter pin extending through the two sections for securing them detachably together.

In testimony that we claim the foregoing as our own, we have hereto affixed our signatures.

CLARENCE EVERETT ULERY.
FRANK CARPENTER FITCH.