



US 20200024913A1

(19) **United States**

(12) **Patent Application Publication**
REN et al.

(10) **Pub. No.: US 2020/0024913 A1**

(43) **Pub. Date: Jan. 23, 2020**

(54) **ROTARY STEERABLE DRILLING SYSTEM WITH ACTIVE STABILIZER**

Publication Classification

(71) Applicant: **General Electric Company**,
Schenectady, NY (US)

(51) **Int. Cl.**
E21B 17/10 (2006.01)
E21B 7/06 (2006.01)

(72) Inventors: **Zhiguo REN**, Shanghai (CN); **Xu FU**,
Shanghai (CN); **Stewart Blake BRAZIL**,
Niskayuna, NY (US); **Chengbao WANG**,
Oklahoma City, OK (US)

(52) **U.S. Cl.**
CPC **E21B 17/1021** (2013.01); **E21B 7/06**
(2013.01)

(21) Appl. No.: **16/476,174**

(57) **ABSTRACT**

(22) PCT Filed: **Jan. 5, 2018**

A drilling system includes a drill string for connecting with a drill bit for drilling a borehole, a fixed stabilizer fixed on the drill string, and an active stabilizer including a body and actuators connecting the body and the drill string. The actuators are capable of driving the drill string away from a center of the borehole with a displacement. The body has an outer surface for contacting a wall of the borehole, an inner surface facing the drill string, and at least one guiding portion projecting from the inner surface and each defining at least one groove. The drill string includes at least one sliding portion slidable within the at least one groove respectively to constrain movement between the drill string and the active stabilizer along an axial direction of the drill string and guide movement between the drill string and the active stabilizer perpendicular to the axial direction.

(86) PCT No.: **PCT/US2018/012484**

§ 371 (c)(1),

(2) Date: **Jul. 5, 2019**

(30) **Foreign Application Priority Data**

Jan. 5, 2017 (CN) 201710007314.8

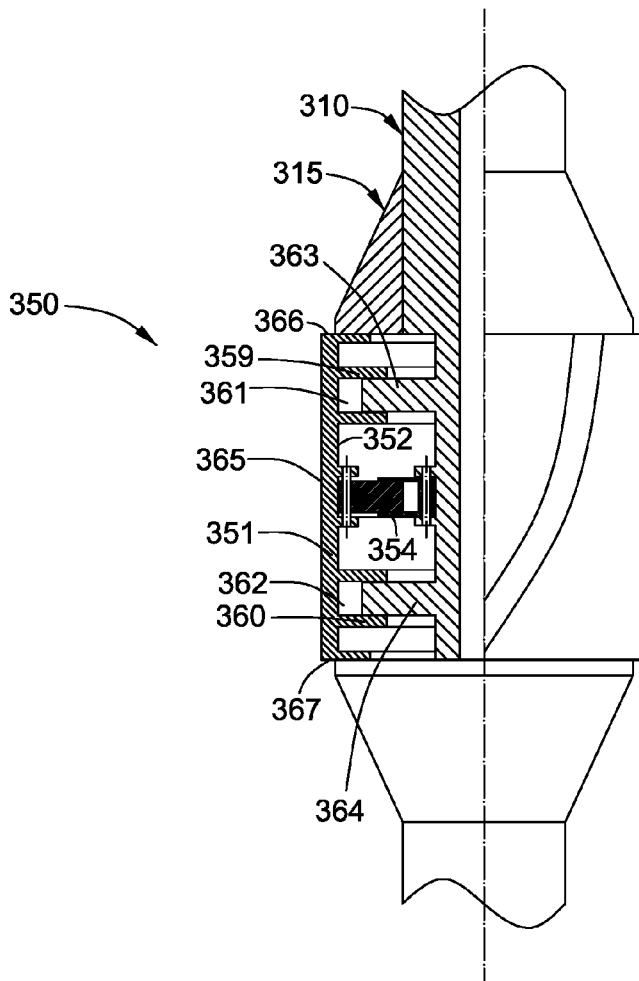

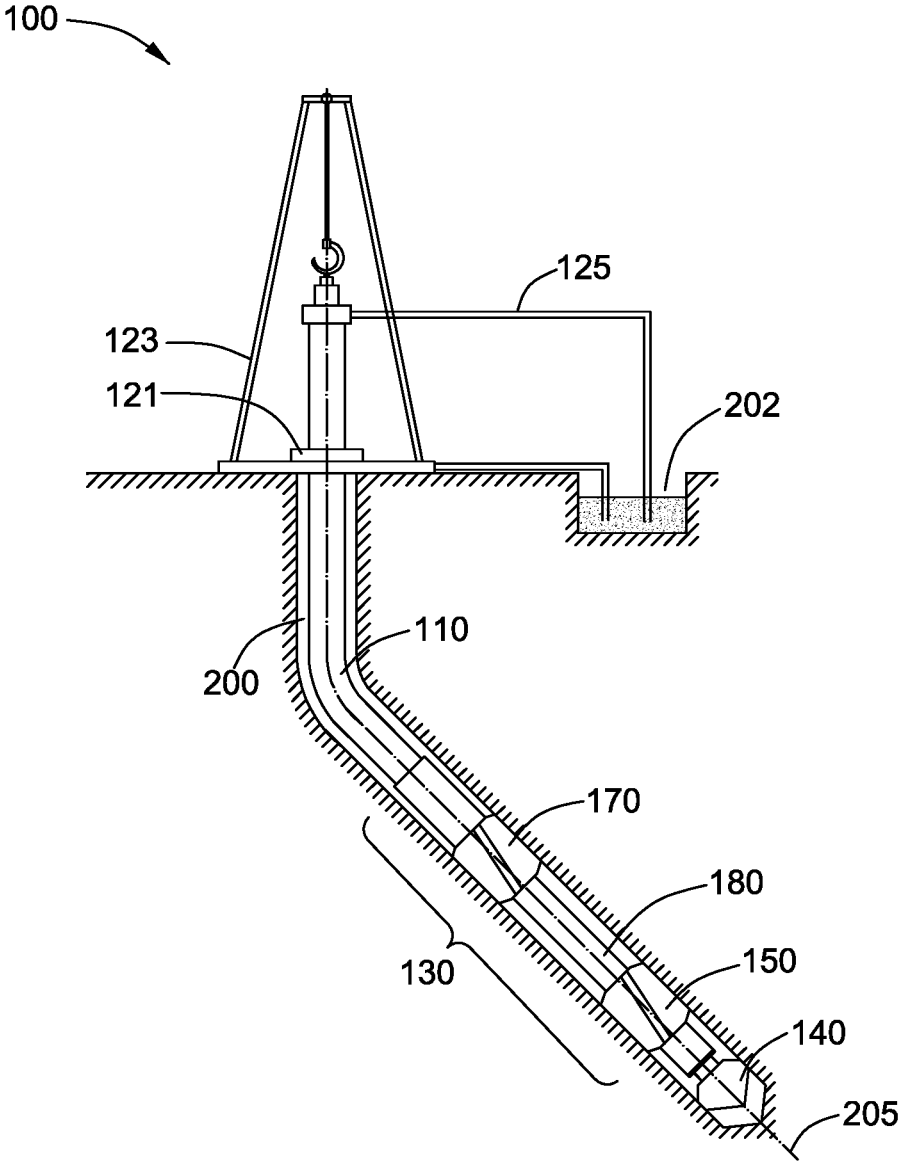

FIG. 1

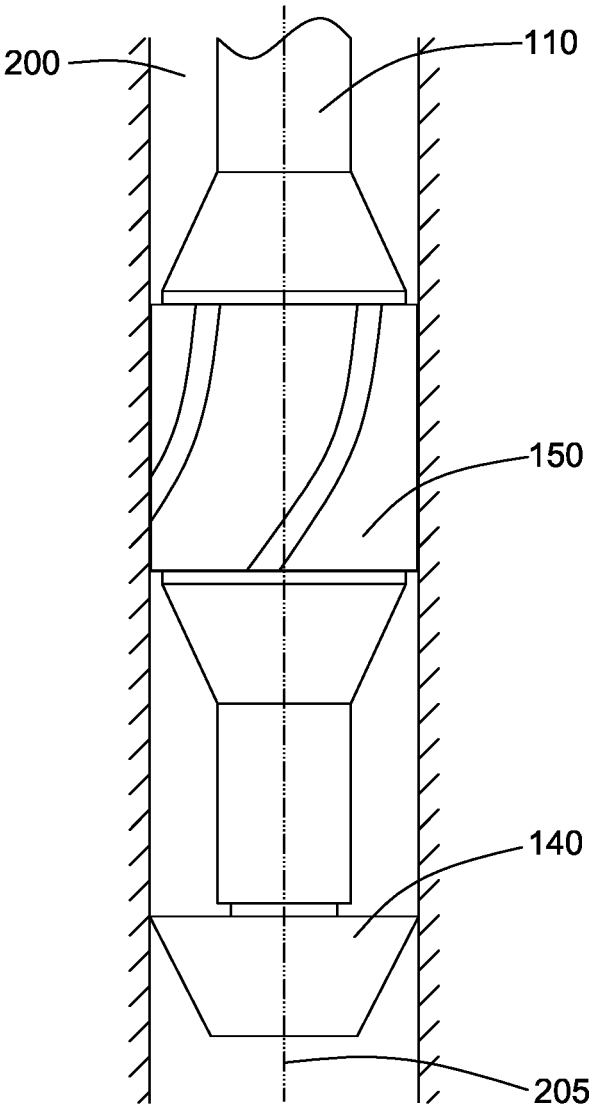

FIG. 2

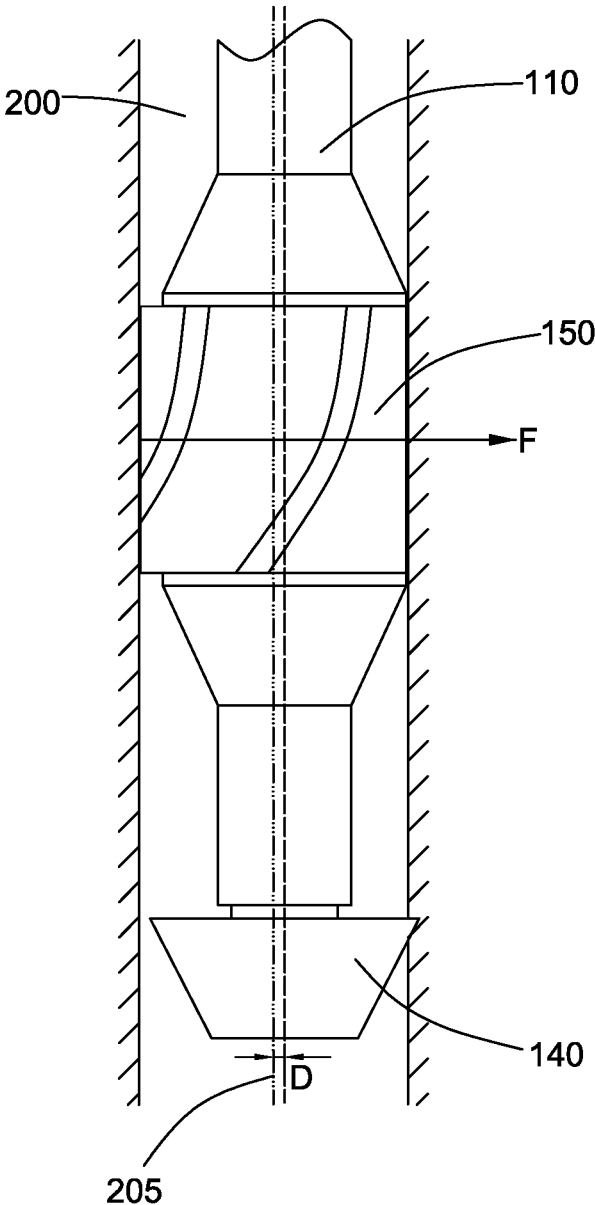

FIG. 3

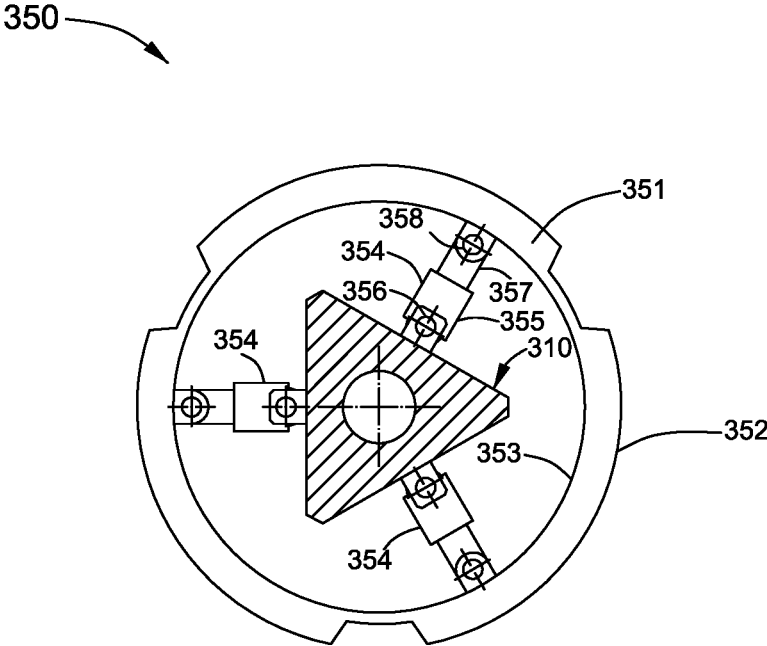

FIG. 4

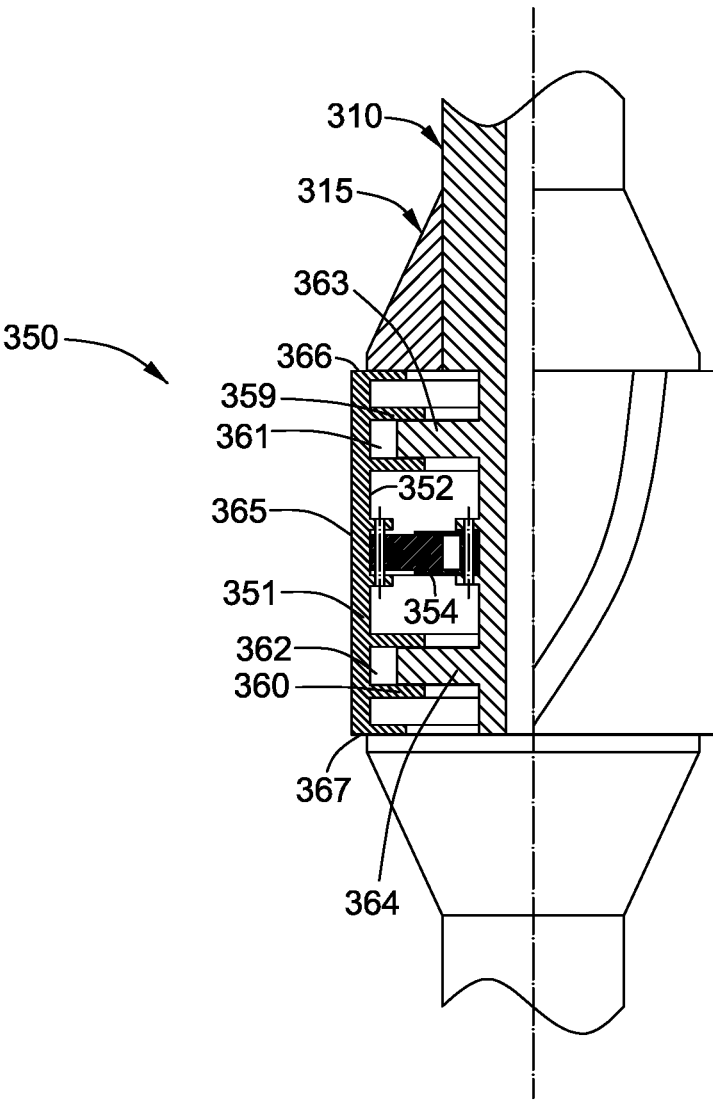

FIG. 5

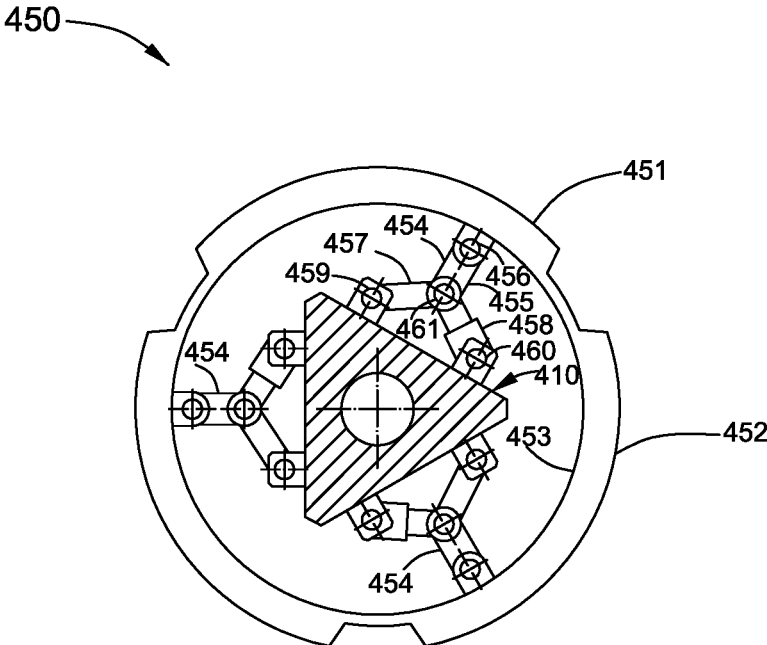

FIG. 6

ROTARY STEERABLE DRILLING SYSTEM WITH ACTIVE STABILIZER

FIELD OF THE INVENTION

[0001] The present invention generally relates to a directional drilling system, and in particular, to a rotary steerable system with an active stabilizer.

BACKGROUND OF THE INVENTION

[0002] An oil or gas well often has a subsurface section that needs to be drilled directionally. Rotary steerable systems, also known as “RSS,” are designed to drill directionally with continuous rotation from the surface, and can be used to drill a wellbore along an expected direction and trajectory by steering a drill string while it’s being rotated. Thus rotary steerable systems are widely used in such as conventional directional wells, horizontal wells, branch wells, etc. Typically, there are two types of rotary steerable systems: “push-the-bit” systems and “point-the-bit” systems, wherein the push-the-bit system has a high build-up rate but forms an unsmooth drilling trajectory and rough well walls, whereas the point-the-bit system forms relatively smoother drilling trajectory and well walls, but has a relatively lower build-up rate.

[0003] The push-the-bit systems use the principle of applying a lateral force to the drill string to push the bit to deviate from the well center to change the drilling direction. The drilling qualities of the existing push-the-bit systems are much subjected to the conditions of well walls. Uneven formation and vibrations of the drill bit during the drilling may cause a rough well wall and an unsmooth drilling trajectory. Thus it is hard to achieve high steering precision. A rough well wall may lead difficulties in casing (well cementing), trip-in and trip-out operations. How to exactly drill a downhole along a desired trajectory with high quality while fully rotating the drill tool is always a challenge.

[0004] Accordingly, there is a need to provide a new rotary steerable system to solve at least one of the above-mentioned technical problems.

SUMMARY OF THE INVENTION

[0005] A drilling system includes a rotatable drill string for connecting with a drill bit for drilling a borehole, at least one fixed stabilizer fixed on the drill string, and an active stabilizer. The fixed stabilizer has an outer surface for contacting a wall of the borehole. The active stabilizer includes a body, and a plurality of actuators connecting the body and the drill string and capable of driving the drill string to deviate away from a center of the borehole with a displacement. The body has an outer surface for contacting a wall of the borehole, an inner surface facing the drill string, and at least one guiding portion projecting from the inner surface towards the drill string. Each guiding portion defines at least one groove. The drill string includes at least one sliding portion, each capable of sliding within one of the at least one groove defined in the body of the active stabilizer, to constrain relative movement between the drill string and the active stabilizer along an axial direction of the drill string and guide relative movement between the drill string and the active stabilizer along a radial direction substantially perpendicular to the axial direction of the drill string.

BRIEF DESCRIPTION OF THE DRAWINGS

[0006] The above and other aspects, features, and advantages of the present disclosure will become more apparent in light of the subsequent detailed description when taken in conjunction with the accompanying drawings in which:

[0007] FIG. 1 is a schematic side view of a rotary steerable system including a drill string, a fixed stabilizer and an active stabilizer.

[0008] FIG. 2 illustrates a first position state of the active stabilizer and the drill string of FIG. 1.

[0009] FIG. 3 illustrates a second position state of the active stabilizer and the drill string of FIG. 1.

[0010] FIG. 4 is a schematic cross sectional view of an active stabilizer that can be used in a rotary steerable system like that of FIG. 1, in accordance with one embodiment of the present disclosure.

[0011] FIG. 5 is a partial longitudinal sectional view illustrating how the active stabilizer of FIG. 4 is coupled to a drill string.

[0012] FIG. 6 is a schematic cross sectional view of an active stabilizer that can be used in a rotary steerable system like that of FIG. 1, in accordance with another embodiment of the present disclosure.

DETAILED DESCRIPTION OF THE INVENTION

[0013] One or more embodiments of the present disclosure will be described below. Unless defined otherwise, technical and scientific terms used herein have the same meaning as is commonly understood by one of skill in the art to which this invention belongs. The terms “first,” “second,” and the like, as used herein do not denote any order, quantity, or importance, but rather are used to distinguish one element from another. Also, the terms “a” and “an” do not denote a limitation of quantity, but rather denote the presence of at least one of the referenced items. The term “or” is meant to be inclusive and mean any, some, or all of the listed items. The use of “including,” “comprising” or “having” and variations thereof herein are meant to encompass the items listed thereafter and equivalents thereof as well as additional items. The term “coupled” or “connected” or the like is not limited to being connected physically or mechanically, but may be connected electrically, directly or indirectly.

[0014] Embodiments of the present disclosure relate to a rotary steerable system for directional drilling a borehole or wellbore. The rotary steerable system involves an active stabilizer and sliding mechanism. The active stabilizer includes a body that can contact a wall of the borehole, and a plurality of actuators that can be controlled to push a drill bit of the rotary steerable system to move against the body of the active stabilizer with the constraint of the sliding mechanism. When the body of the active stabilizer contacts the borehole wall, a lateral force is applied to the body of the active stabilizer to help the actuators to push the drill bit away from a center of the borehole and thereby change the drilling direction during the drilling.

[0015] Referring to FIG. 1, a rotary steerable system **100** is used for directionally drilling a borehole **200** in the earth. The rotary steerable system **100** includes a drill string **110** rotatably driven by a rotary table **121** (or by top drive instead) from the surface and is coupled with a drill bit **140** at a distal end thereof. The drill bit **140** has cutting ability, and once is rotated, is able to cut and advance into the earth

formation. The drill string **110** typically is tubular. A bottom hole assembly (BHA) **130** forms a down-hole near-end section of the drill string **110**, which typically houses measurement control modules and/or other devices necessary for control of the rotary steerable system. The length of the drill string **110** can be increased as it progresses deeper into the earth formation, by connecting additional sections of drill string thereto.

[0016] In addition to the rotary table **121** for providing a motive force to rotate the drill string **110**, the rotary steerable system **100** may further include a drilling rig **123** for supporting the drill string **110**, and a mud tube **125** for transferring mud from a mud pool **202** to the drill string **110** by a mud pump (not shown). The mud may serve as a lubricating fluid and be repeatedly re-circulated from the mud pool **202**, through the mud tube **125**, the drill string **110** and the drill bit **140**, under pressure, to the borehole **200**, to take away cuttings (rock pieces) that are generated during the drilling back to the mud pool **202** for reuse after the cuttings are separated and removed from the mud by, such as filtration.

[0017] In order to achieve directional control while drilling, the rotary steerable system **100** may include an active stabilizer **150**, which is capable of stabilizing the drill string **110** against undesired radial shaking to keep the drill string **110** at the center of the borehole **200** when the drilling is along a straight direction, as well as driving the drill string **110** to deviate away from a center of the borehole **200** being drilled in order to change the drilling direction when it is needed to change the drilling direction during the drilling. As shown in FIG. 2, when the rotary steerable system is drilling along a straight direction, a center axis of the drill string **110** substantially coincides with a center axis **205** of the borehole **200** around the position of the active stabilizer **150**, and an outer surface of the active stabilizer **150** contacts the inner surface of the borehole **200** to reduce or prevent undesired radial shaking. When it is needed to change the drilling direction while drilling, the active stabilizer **150** may push the drill string **110** to make the center axis of the drill string **110** around the position of the active stabilizer **150** deviate away from the borehole center with a desired displacement, and keep the displacement while the drill string **110** is rotating. As shown in FIG. 3, the active stabilizer **150** abuts on the inner surface of the borehole **200** to apply a lateral force F to the drill string **110** to push the drill string **110** to make the center axis of the drill string **110** around the position of the active stabilizer **150** deviate away from the center axis **205** of the borehole **200** with a desired displacement D along a desired direction.

[0018] During the drilling, there may be a continuous contact between the active stabilizer **150** and the inner surface of the borehole **200**, and therefore the drill string **110** may be continuously pushed by the active stabilizer to deviate so as to change the drilling direction when it is needed. Moreover, there is less impact from borehole rugosity, and the active stabilizer **150** can also function as a general stabilizer for stabilizing the drill string **310** against undesired radial shaking during the drilling.

[0019] Returning to FIG. 1, the rotary steerable system **100** may further include one or more fixed stabilizers **170** fixed on the drill string **110**. In some embodiments, the one or more fixed stabilizers are fixed to prevent relative movement between the stabilizers **170** and the drill string **110**. In some embodiments, the one or more fixed stabilizers **170** are

above the active stabilizer **150**, i.e., farther away from the drill bit **140** at the distal end of the drill string **110**, compared with the active stabilizer **150**. The fixed stabilizer **170** has an outer surface for contacting a wall of the borehole **200**, and can stabilize the drill string **110** against radial shaking during the drilling to keep the drill string **110** at the center of the borehole **200**. In some embodiments, the fixed stabilizer **170** includes an annular structure having an outer diameter slightly smaller than the diameter of the borehole. The active stabilizer **150** and the nearest fixed stabilizer **170** may be connected through a slightly flexible structure **180**, for example, a string section with a thinner wall comparing with other sections of the drill string **110**. The string section between the two stabilizers may bend a little while changing the drilling direction, which may improve the built-up rate and smoothness of the drilling trajectory.

[0020] FIGS. 4 and 5 illustrate an active stabilizer **350** that can be used in a rotary steerable system like the system **100** of FIG. 1. The active stabilizer **350** includes a body **351** having an outer surface **352** for contacting a wall of a borehole being drilled and an inner surface **353** facing a drill string **310**. The active stabilizer **350** further includes a plurality of actuators **354** connecting the body **351** and the drill string **310**. In the specific embodiment as illustrated in FIG. 4, there are three such actuators **354**. Each of the actuators **354** includes a cylinder **355** rotatably coupled to one of the drill string **310** and the body **351** through a first pivot joint **356**, and a piston **357** rotatably coupled to the other of the drill string **310** and the body **351** through a second pivot joint **358**. The piston **357** is driven by a hydraulic system and is movable within the cylinder **355**. Therefore, as for each actuator **354**, the cylinder **355** is rotatable around the first pivot joint **356**, the piston **357** is rotatable around the second pivot joint **358**, and the piston **357** is movable within the cylinder **355**. The plurality of actuators **354** are capable of driving the drill string **310** to deviate away from the borehole center with a displacement and stabilizing the drill string **310** against undesired radial shaking during the drilling.

[0021] The body **351** of the active stabilizer **350** further includes at least one guiding portion **359/360** projecting from the inner surface **353** towards the drill string **310**, wherein each guiding portion **359/360** defines at least one groove **361/362**. The drill string **310** includes at least one sliding portion **363/364**, each capable of sliding within one of the at least one groove **361/362** defined in the body **351** of the active stabilizer **350**, to constrain relative movement between the drill string **310** and the active stabilizer **350** along an axial direction of the drill string **310** and guide relative movement between the drill string **310** and the active stabilizer **350** along a radial direction substantially perpendicular to the axial direction of the drill string **310**. In some embodiments, the at least one sliding portion **363/364** projects outward from an outer surface of the drill string **310**. In some embodiments, the sliding portion **363/364** is a sliding disk. In some embodiments, the groove **361/362** is an annular groove.

[0022] In some embodiments, the body **351** of the active stabilizer **350** includes an annular structure **365** having an outer diameter slightly smaller than the diameter of the borehole being drilled. An outer peripheral surface of the annular structure **365** contacts the borehole wall to help the actuators to push the drill bit away from the borehole center. In some embodiments, the annular structure **365** has oppo-

site first and second axial ends **366** and **367**, and the at least one guiding portion includes a first guiding portion **359** between the first axial end **366** of the annular structure **365** and the plurality of actuators **354** and a second guiding portion **360** between the second axial end **367** of the annular structure **365** and the plurality of actuators **354**, along an axial direction of the annular structure.

[0023] The at least one guiding portion at the body **351** of the active stabilizer **350** and the at least one sliding portion at the drill string **310** coordinate with each other to guide the movement between the active stabilizer **350** and the drill string **310**. By such a sliding mechanism, the motion and displacement of the active stabilizer can be accurately controlled, and undesired shaking and vibrations can be reduced.

[0024] There may be one or more measurement control modules and/or other devices, included in the rotary steerable system, for driving and controlling the plurality of actuators. For example, there may be a hydraulic system for driving the plurality of actuators, a measurement module for continuously measuring or estimating displacements of the plurality of actuators, a measurement module for continuously measuring a drilling direction of the drill bit during the drilling, and/or a controller for harmoniously controlling the plurality of actuators based on measurement or estimation of displacements of the plurality of actuators. In some embodiments, a measurement while drilling (MWD) module is used to continuously measure the bit position and directions (gesture), and the measurement results can be used to harmoniously control the hydraulic pistons to change the drilling direction to reach high drilling quality.

[0025] FIG. 6 illustrates another active stabilizer **450** that can be used in a rotary steerable system like the system **100** of FIG. 1. Similar to the active stabilizer **350**, the active stabilizer **450** includes a body **451** having an outer surface **452** for contacting a wall of a borehole being drilled and an inner surface **453** facing a drill string **410**, and a plurality of actuators **454** connecting the body **451** and the drill string **410**.

[0026] Each of the actuators **454** includes a first link element **455** rotatably coupled to the body **451** via a first pivot joint **456**, a second link element **457** and a third link element **458** rotatably coupled to the drill string **410** via a second pivot joint **459** and a third pivot joint **460**, respectively. The first, second and third link elements **455**, **457**, **458** are connected via a fourth pivot joint **461**. The third and fourth pivot joints **460**, **461** are movable towards each other or away from each other. In some embodiments, the third link element **458** includes a cylinder and a piston movable within the cylinder. The plurality of actuators **454** are capable of driving the drill string **410** to deviate away from the borehole center with a displacement and stabilizing the drill string **410** against radial shaking during the drilling. By continuously and harmoniously controlling the plurality of actuators **454** to drive the drill string **310** to deviate away, the drilling direction can be changed according to a predetermined trajectory.

[0027] Similar to the active stabilizer **350**, the active stabilizer **450** also has a sliding mechanism including at least one guiding portion at the body **451** of the active stabilizer **450** and at least one sliding portion at the drill string **410**, which coordinate with each other to guide the movement between the active stabilizer **450** and the drill string **410**. The

specific implementation way of the sliding mechanism may be the same as that in the active stabilizer **350**, and therefore will not be repeated.

[0028] While the invention has been described with reference to a preferred embodiment, it will be understood by those skilled in the art that various changes may be made and equivalents may be substituted for elements thereof without departing from the scope of the invention. In addition, many modifications may be made to adapt a particular situation or material to the teachings of the invention without departing from the essential scope thereof. Therefore, it is intended that the invention not be limited to the particular embodiment disclosed as the best mode contemplated for carrying out this invention, but that the invention will include all embodiments falling within the scope of the appended claims.

1. A drilling system, comprising:

- a rotatable drill string for connecting with a drill bit for drilling a borehole;
- at least one fixed stabilizer fixed on the drill string and having an outer surface for contacting a wall of the borehole; and

an active stabilizer comprising:

- a body having an outer surface for contacting a wall of the borehole, an inner surface facing the drill string, and at least one guiding portion projecting from the inner surface towards the drill string, each guiding portion defining at least one groove; and
- a plurality of actuators connecting the body and the drill string, the plurality of actuators capable of driving the drill string to deviate away from a center of the borehole with a displacement,

wherein the drill string comprises at least one sliding portion, each capable of sliding within one of the at least one groove defined in the body of the active stabilizer, to constrain relative movement between the drill string and the active stabilizer along an axial direction of the drill string and guide relative movement between the drill string and the active stabilizer along a radial direction substantially perpendicular to the axial direction of the drill string.

2. The system according to claim 1, wherein each of the actuators comprises a cylinder rotatably coupled to one of the drill string and the body of the active stabilizer and a piston rotatably coupled to the other of the drill string and the body of the active stabilizer, the piston movable within the cylinder.

3. The system according to claim 1, wherein each of the actuators comprises a first link element rotatably coupled to the body of the active stabilizer via a first joint, a second link element and a third link element rotatably coupled to the drill string via a second joint and a third joint, respectively, wherein the first, second and third link elements are connected via a fourth joint, and the third and fourth joints are movable towards each other or away from each other.

4. The system according to claim 3, wherein the third link element comprises a cylinder and a piston movable within the cylinder.

5. The system according to claim 1, wherein the body of the active stabilizer comprises an annular structure having opposite first and second axial ends, and the at least one guiding portion comprises a first guiding portion between the first axial end of the annular structure and the plurality of actuators and a second guiding portion between the

second axial end of the annular structure and the plurality of actuators, along an axial direction of the annular structure.

6. The system according to claim 1, wherein the at least one sliding portion projects outward from an outer surface of the drill string.

7. The system according to claim 1, wherein a maximum diameter of the active stabilizer is slightly smaller than a diameter of the borehole.

8. The system according to claim 1, further comprising a hydraulic system for driving the plurality of actuators.

9. The system according to claim 1, further comprising a controller for harmoniously controlling the plurality of actuators based on measurement or estimation of displacements of the plurality of actuators.

10. The system according to claim 1, further comprising a measurement module for continuously measuring a drilling direction of the drill bit during the drilling, to control the drilling direction.

11. The system according to claim 1, wherein the active stabilizer and the nearest fixed stabilizer are connected through a flexible structure.

* * * * *