

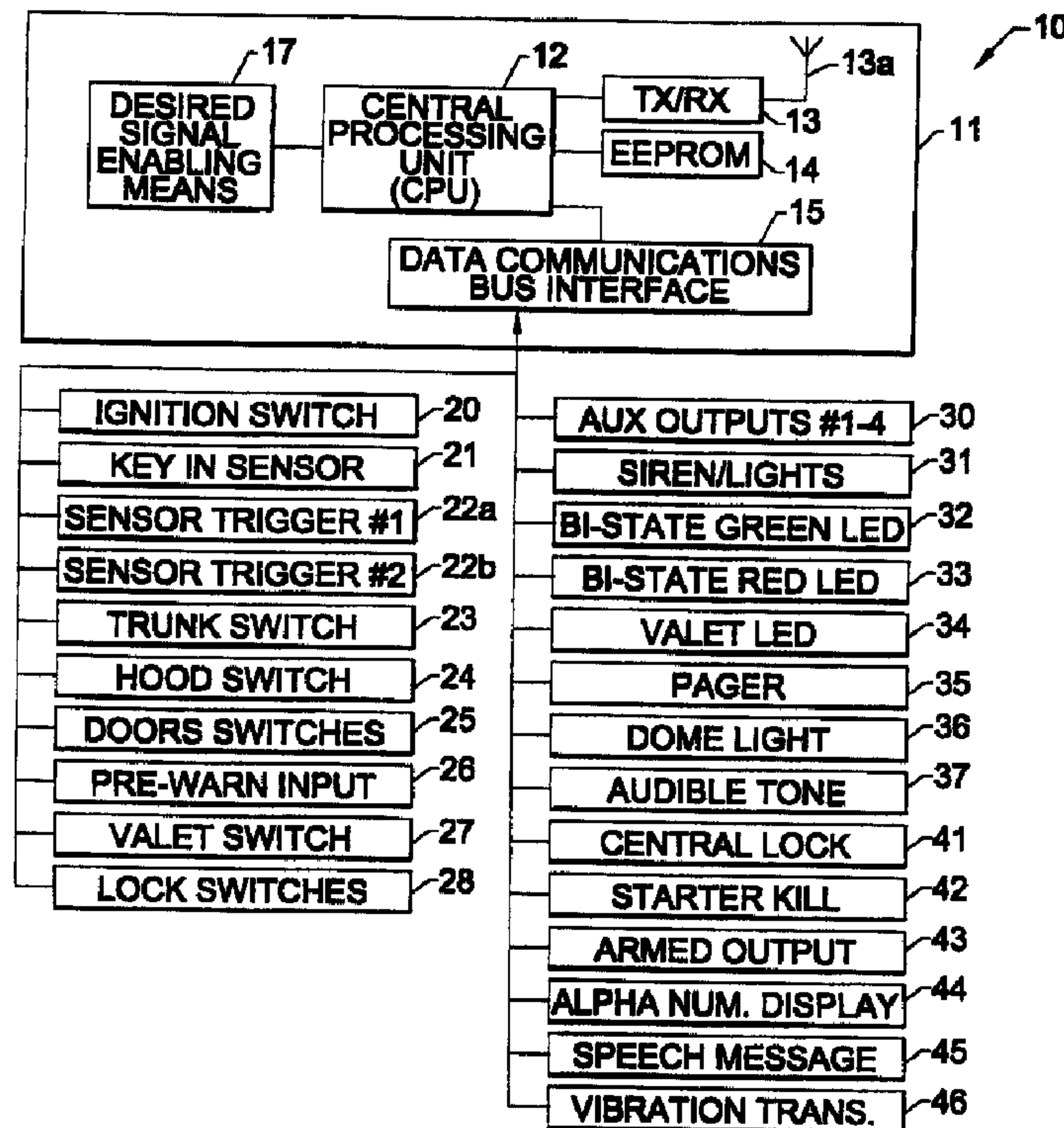

(86) Date de dépôt PCT/PCT Filing Date: 1998/02/13  
 (87) Date publication PCT/PCT Publication Date: 1999/08/19  
 (45) Date de délivrance/Issue Date: 2003/12/02  
 (85) Entrée phase nationale/National Entry: 2000/08/08  
 (86) N° demande PCT/PCT Application No.: US 1998/002896  
 (87) N° publication PCT/PCT Publication No.: 1999/041108

(51) Cl.Int.<sup>6</sup>/Int.Cl.<sup>6</sup> B60R 16/02, B60R 25/10, B60R 25/04, E05B 49/00  
 (72) Inventeur/Inventor: FLICK, KENNETH E., US  
 (73) Propriétaire/Owner: FLICK, KENNETH E., US  
 (74) Agent: GOUDREAU GAGE DUBUC

(54) Titre : SYSTEME DE SECURITE POUR VEHICULE PRESENTANT UN BUS DE COMMUNICATION DE DONNEES ET PROCEDES ASSOCIES  
 (54) Title: VEHICLE SECURITY SYSTEM FOR A VEHICLE HAVING A DATA COMMUNICATIONS BUS AND RELATED METHODS



(57) Abrégé/Abstract:

A vehicle security system includes a vehicle security sensor and associated sensor bus interface (60), an alarm indicator and associated alarm indicator bus interface (64), and an alarm controller and associated alarm controller bus interface (65) for interfacing the alarm controller. The vehicle security system is for a vehicle of a type including a data communications bus (62)

**(57) Abrégé(suite)/Abstract(continued):**

connecting a plurality of vehicle devices. The security system preferably further includes a desired signal enabling circuit (17) for enabling the alarm controller to operate using a set (72a, 72b, 72n) of desired signals for a desired vehicle from among a plurality of possible sets of signals for different vehicles. Accordingly, the desired signal enabling circuit (17) permits the alarm controller to communicate with the vehicle security sensor and the alarm indicator via the data communications bus so that the alarm controller is capable of operating the alarm indicator responsive to the vehicle security sensor. The desired signal enabling circuit may preferably include a memory for storing a plurality of respective sets of signals for different vehicles, and a selecting circuit for selecting the desired set of signals from the plurality of different sets of signals for different vehicles. The desired signal enabling circuit may also be included in other vehicle remote control systems. Method aspects of the invention are also disclosed.



PCT

WORLD INTELLECTUAL PROPERTY ORGANIZATION  
International Bureau

INTERNATIONAL APPLICATION PUBLISHED UNDER THE PATENT COOPERATION TREATY (PCT)

<p>(51) International Patent Classification <sup>6</sup> : <b>B60R 16/02, 25/10, 25/04, E05B 49/00</b></p>	<p><b>A1</b></p>	<p>(11) International Publication Number: <b>WO 99/41108</b> (43) International Publication Date: 19 August 1999 (19.08.99)</p>
--	------------------	---

<p>(21) International Application Number: PCT/US98/02896 (22) International Filing Date: 13 February 1998 (13.02.98) (71)(72) Applicant and Inventor: FLICK, Kenneth, E. [US/US]; 5236 Presley Place, Douglasville, GA 30135 (US). (74) Agent: REGAN, Christopher, F.; Allen, Dyer, Doppelt, Milbrath &amp; Gilchrist, Suite 1401, 255 South Orange Avenue, P.O. Box 3791, Orlando, FL 32802-3791 (US).</p>	<p>(81) Designated States: AL, AM, AT, AU, AZ, BA, BB, BG, BR, BY, CA, CH, CN, CU, CZ, DE, DK, EE, ES, FI, GB, GE, HU, IL, IS, JP, KE, KG, KP, KR, KZ, LC, LK, LR, LS, LT, LU, LV, MD, MG, MK, MN, MW, MX, NO, NZ, PL, PT, RO, RU, SD, SE, SG, SI, SK, TJ, TM, TR, TT, UA, UG, US, UZ, VN, ARIPO patent (GH, GM, KE, LS, MW, SD, SZ, UG, ZW), Eurasian patent (AM, AZ, BY, KG, KZ, MD, RU, TJ, TM), European patent (AT, BE, CH, DE, DK, ES, FI, FR, GB, GR, IE, IT, LU, MC, NL, PT, SE), OAPI patent (BF, BJ, CF, CG, CI, CM, GA, GN, ML, MR, NE, SN, TD, TG).</p> <p><b>Published</b> <i>With international search report.</i></p>
---	--

(54) Title: VEHICLE SECURITY SYSTEM FOR A VEHICLE HAVING A DATA COMMUNICATIONS BUS AND RELATED METHODS

(57) Abstract

A vehicle security system includes a vehicle security sensor and associated sensor bus interface (60), an alarm indicator and associated alarm indicator bus interface (64), and an alarm controller and associated alarm controller bus interface (65) for interfacing the alarm controller. The vehicle security system is for a vehicle of a type including a data communications bus (62) connecting a plurality of vehicle devices. The security system preferably further includes a desired signal enabling circuit (17) for enabling the alarm controller to operate using a set (72a, 72b, 72n) of desired signals for a desired vehicle from among a plurality of possible sets of signals for different vehicles. Accordingly, the desired signal enabling circuit (17) permits the alarm controller to communicate with the vehicle security sensor and the alarm indicator via the data communications bus so that the alarm controller is capable of operating the alarm indicator responsive to the vehicle security sensor. The desired signal enabling circuit may preferably include a memory for storing a plurality of respective sets of signals for different vehicles, and a selecting circuit for selecting the desired set of signals from the plurality of different sets of signals for different vehicles. The desired signal enabling circuit may also be included in other vehicle remote control systems. Method aspects of the invention are also disclosed.

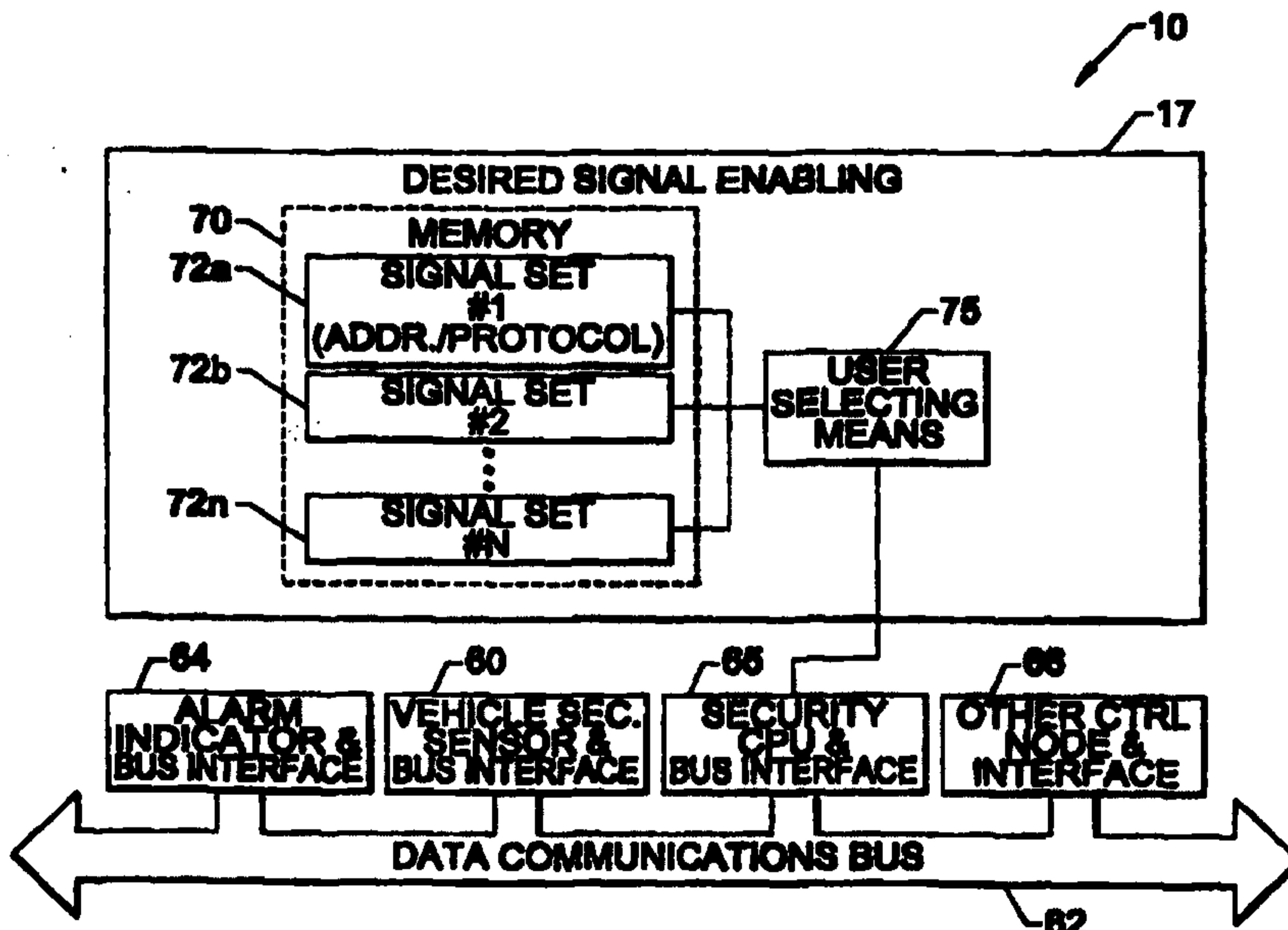

**VEHICLE SECURITY SYSTEM FOR A VEHICLE  
HAVING A DATA COMMUNICATIONS BUS  
AND RELATED METHODS**

**Field of the Invention**

This application is related to the field of security systems and, more particularly, to a security system and related methods for vehicles.

**Background of the Invention**

5           Vehicle security systems are widely used to deter vehicle theft, prevent theft of valuables from a vehicle, deter vandalism, and to protect vehicle owners and occupants. A typical automobile security system, for example, includes a central processor or controller  
10 connected to a plurality of vehicle sensors. The sensors, for example, may detect opening of the trunk, hood, doors, windows, and also movement of the vehicle or within the vehicle. Ultrasonic and microwave motion detectors, vibration sensors, sound discriminators,  
15 differential pressure sensors, and switches may be used as sensors. In addition, radar sensors may be used to monitor the area proximate the vehicle.

          The controller typically operates to give an alarm indication in the event of triggering of a vehicle  
20 sensor. The alarm indication may typically be a flashing of the lights and/or the sounding of the vehicle horn or a siren. In addition, the vehicle fuel supply and/or ignition power may be selectively disabled based upon an alarm condition.

-2-

A typical security system also includes a receiver associated with the controller that cooperates with one or more remote transmitters typically carried by the user as disclosed, for example, in U.S. Patent No. 4,383,242 to Sassover et al. and U.S. Patent No. 5,146,215 to Drori. The remote transmitter may be used to arm and disarm the vehicle security system or provide other remote control features from a predetermined range away from the vehicle. Also related to remote control of a vehicle function U.S. Patent No. 5,252,966 to Lambropoulos et al. discloses a remote keyless entry system for a vehicle. The keyless entry system permits the user to remotely open the vehicle doors or open the vehicle trunk using a small handheld transmitter.

Unfortunately, the majority of vehicle security systems need to be directly connected by wires to individual vehicle devices, such as the vehicle horn or door switches of the vehicle. In other words, a conventional vehicle security system is hardwired to various vehicle components, typically by splicing into vehicle wiring harnesses or via interposing T-harnesses and connectors. The number of electrical devices in a vehicle has increased so that the size and complexity of wiring harnesses has also increased. For example, the steering wheel may include horn switches, an airbag, turn-signal and headlight switches, wiper controls, cruise control switches, ignition wiring, an emergency flasher switch, and/or radio controls. Likewise, a door of a vehicle, for example, may include window controls, locks, outside mirror switches, and/or door-panel light switches.

In response to the increased wiring complexity and costs, vehicle manufacturers have begun attempts to reduce the amount of wiring within vehicles to reduce weight, reduce wire routing problems, decrease costs, and reduce complications which may arise when

-3-

troubleshooting the electrical system. For example, some manufacturers have adopted multiplexing schemes to reduce cables to three or four wires and to simplify the exchange of data among the various onboard  
5 electronic systems as disclosed, for example, in "The Thick and Thin of Car Cabling" by Thompson appearing in the IEEE Spectrum, Feb. 1996, pp. 42-45.

Implementing multiplexing concepts in vehicles in a cost-effective and reliable manner may not be easy.  
10 Successful implementation, for example, may require the development of low or error-free communications in what can be harsh vehicle environments. With multiplexing technology, the various electronic modules or devices may be linked by a single signal wire in a bus also  
15 containing a power wire, and one or more ground wires. Digital messages are communicated to all modules over the data communications bus. Each message may have one or more addresses associated with it so that the devices can recognize which messages to ignore and  
20 which messages to respond to or read.

The Thompson article describes a number of multiplexed networks for vehicles. In particular, the Grand Cherokee made by Chrysler is described as having five multiplex nodes or controllers: the engine  
25 controller, the temperature controller, the airbag controller, the theft alarm, and the overhead console. Other nodes for different vehicles may include a transmission controller, a trip computer, an instrument cluster controller, an antilock braking controller, an  
30 active suspension controller, and a body controller for devices in the passenger compartment.

A number of patent references are also directed to digital or multiplex communications networks or circuits, such as may be used in a vehicle. For  
35 example, U.S. Patent No. 4,538,262 Sinniger et al. discloses a multiplex bus system including a master control unit and a plurality of receiver-transmitter

units connected thereto. Similarly, U.S. Patent No. 4,055,772 to Leung discloses a power bus in a vehicle controlled by a low current digitally coded Communications system. Other references disclosing  
5 various vehicle multiplex control systems include, for example, U.S. Patent No. 4,760,275 to Sato et al.; U.S. Patent No. 4,697,092 to Roggendorf et al.; and U.S. Patent No. 4,792,783 to Burgess et al.

German Patent No. DE 19530721A1 to Jahrsete  
10 et al. discloses a control system for the electrical components of a vehicle that includes a vehicle theft alarm connected to a multiplex single-conductor bus. The control system further discloses a transponder interrogation transceiver actuated by a transponder.  
15 The transponder interrogation transceiver and the transponder can each be equipped with code word memories in which code words can be stored. Upon activation of the transceiver, the transceiver can interrogate the transponder to derive the stored code  
20 word therefrom and compare it with the code word stored in the transceiver. Based upon the comparison, a plurality of vehicle devices connected to the bus can be activated or deactivated.

Several standards have been proposed for  
25 vehicle multiplex networks including, for example, the Society of Automotive Engineers "Surface Vehicle Standard, Class B Data Communications Network Interface", SAE J1850, July 1995. Another report by the SAE is the "Surface Vehicle Information Report,  
30 Chrysler Sensor and Control (CSC) Bus Multiplexing Network for Class 'A' Applications", SAE J2058, July 1990. Many other networks are also being implemented or proposed for communications between vehicle devices and nodes or controllers.

35 Unfortunately, conventional vehicle security systems for hardwired connection to vehicle devices, such as aftermarket vehicle security systems, are not

-4a-

readily adaptable to a vehicle including a data communications bus. Moreover, a vehicle security system if adapted for a communications bus and devices for one particular model, model year, and manufacturer, may not be compatible with any other models, model years, or manufacturers. Other systems for remote control of vehicle functions may also suffer from such shortcomings.

10

**Summary of the Invention**

In view of the foregoing background, it is therefore an object of the present invention to provide a vehicle security system and associated method which is readily adapted or adaptable for installation in a vehicle having a data communications bus.

-5-

It is another object of the present invention to provide a security system or other remote control function systems and associated methods for installation in a vehicle having a data communications bus, and wherein the vehicle is one from among a plurality of different vehicles with different device addresses and/or signal protocols for communicating with the vehicle devices.

These and other objects, advantages and features of the present invention are provided by a vehicle security system for a vehicle of a type including a data communications bus connecting a plurality of vehicle devices. In particular, the vehicle security system preferably comprises a vehicle security sensor and associated sensor bus interface means for interfacing the vehicle security sensor to the data communications bus. The vehicle security system also preferably includes an alarm indicator and associated alarm indicator bus interface means for interfacing the alarm indicator to the data communications bus. An alarm controller and associated alarm controller bus interface means are also preferably included. The security system further preferably comprises desired signal enabling means for enabling the alarm controller to operate using a desired set of signals for a desired vehicle from among a plurality of possible sets of signals for different vehicles. Accordingly, the desired signal enabling means permits the alarm controller to communicate with the vehicle security sensor and the alarm indicator via the data communications bus so that the alarm controller is capable of operating the alarm indicator responsive to the vehicle security sensor. The security system is thus advantageously compatible with many different types of vehicle data communications formats or protocols.

-6-

The data communications bus may preferably be a multiplexed data bus. Accordingly, the sensor bus interface means, the alarm bus interface means, and the alarm controller bus interface means may each comprise  
5 multiplexing means for interfacing with the multiplexed data bus of the vehicle.

The desired signal enabling means may preferably include memory means for storing a plurality of sets of signals for different vehicles, and selecting means for  
10 selecting the desired set of signals from the plurality of different sets of signals. In one embodiment, the selecting means may comprise user selecting means for permitting a user to select the desired set of signals. In another embodiment, the selecting means may comprise  
15 determining means for determining the desired set of signals based upon signals on the data communications bus.

The memory means may include device address memory means for storing a plurality of different sets of  
20 signals representative of different device addresses for different vehicles. Alternatively, or in addition thereto, the memory means may comprise protocol memory means for storing a plurality of different protocols for different vehicles.

In yet another embodiment, the desired signal  
25 enabling means may comprise learning means for learning the desired set of signals. For example, the learning means may comprise downloading learning means for learning the desired set of signals from another  
30 device, such as a temporarily connected portable laptop computer, and/or central station. In particular, the security system may interface to a cellular telephone or satellite receiver and the desired set of signals may be downloaded from a central station, or may be  
35 downloaded from a computer temporarily connected to the security system. In another variation, the learning means may comprise bus learning means for learning the

-7-

desired set of signals based upon signals on the data communications bus. The security system, according to another aspect of the invention, may also interface with an existing vehicle controller or a communications bus node which is operatively connected to the data communications bus.

A method aspect of the invention is for operating a vehicle security system for a vehicle of a type including a data communications bus connecting a plurality of vehicle devices. The method preferably comprises the steps of interfacing an alarm controller to the data communications bus, and enabling the alarm controller to operate using a desired set of digital signals for a desired vehicle from a plurality of sets of signals for different vehicles to thereby permit the alarm controller to communicate with at least one of a vehicle security sensor and an alarm indicator via the data communications bus. Accordingly, the alarm controller is capable of operating the alarm indicator responsive to the vehicle security sensor and via the data communication bus.

The concepts and features of the invention may also be desirably incorporated in a remote control system for a vehicle, such as a vehicle security system, a remote engine starter system, or a remote keyless entry system, for example. The remote control system preferably comprises a remote transmitter and a receiver within the vehicle for receiving a signal from the remote transmitter. A vehicle function controller is provided along with an associated vehicle function controller bus interface means for interfacing the vehicle function controller to the data communications bus. The remote control system also includes desired signal enabling means for causing the vehicle function controller to operate using a desired set of signals for a desired vehicle from a plurality of possible sets of digital signals for different vehicles. Accordingly,

the vehicle function controller can communicate with a vehicle device via the data communications bus so that the vehicle function controller is capable of operating the vehicle device responsive to the remote transmitter. Method aspects of this embodiment of the invention are also disclosed.

**Brief Description of the Drawings**

FIG. 1 is a schematic block diagram of the vehicle security system in accordance with the invention.

10 FIG. 2 is a schematic diagram of a remote transmitter of the vehicle security system in accordance with the invention.

15 FIG. 3 is a schematic block diagram of a portion of a first embodiment of the vehicle security system in accordance with the present invention.

FIG. 4 is a schematic block diagram of a portion of a second embodiment of the vehicle security system in accordance with the present invention.

20 FIG. 5 is a schematic block diagram of a portion of a third embodiment of the vehicle security system in accordance with the present invention.

FIG. 6A is a schematic block diagram of a portion of a fourth embodiment of the vehicle security system in accordance with the present invention.

25 FIG. 6B is a schematic block diagram of a portion of a variation of the fourth embodiment of the vehicle security system in accordance with the present invention.

30 FIG. 7 is a schematic block diagram of the vehicle security system in accordance with the present invention.

FIG. 8 is a schematic block diagram of a remote keyless entry system in accordance with the present invention.

35 FIG. 9 is a schematic block diagram of a remote engine starting system in accordance with the present invention.

Detailed Description of the Preferred Embodiments

The present invention will now be described more fully hereinafter with reference to the accompanying drawings in which preferred embodiments of the invention are shown. This invention may, however, be embodied in many different forms and should not be construed as limited to the illustrated embodiments set forth herein. Rather, these embodiments are provided so that this disclosure will be thorough and complete, and will fully convey the scope of the invention to those skilled in the art. Like numbers refer to like elements throughout. Prime and multiple prime notation are used in alternate embodiments to indicate similar elements.

Referring now to the schematic block diagram of FIG. 1, a vehicle security system 10 according to one aspect of the invention is first described. The security system includes a controller 11 which, in turn, in the illustrated embodiment includes a central processing unit (CPU) or microprocessor 12 operating under stored program control.

In the illustrated embodiment, a transmitter and receiver 13 are connected to the CPU 12 for receiving signals from a remote transmitter and for transmitting signals to a remote unit, as will be described in greater detail below. As would be readily understood by those skilled in the art, the transmitter portion of the controller 11 may not be needed in some embodiments of the invention. An antenna 13a is illustratively connected to the transmitter and receiver 13.

In the illustrated embodiment, the CPU 12 is also operatively connected to a memory (EEPROM) 14 and a data communications bus interface 15 which provides both input and output interfaces to various vehicle devices. As would be readily understood by those

-10-

skilled in the art, the CPU 12 may alternately or additionally have its own on-board memory.

The data communications bus interface 15 is illustratively connected to various vehicle input devices including: an ignition switch 20; a key in the ignition sensor 21; two zone sensors 22a, 22b; conventional trunk hood and door pin sensors or switches 23, 24, and 25, respectively; and door lock switches 28. In addition, a pre-warn sensor 26 and valet switch 27 also provide inputs to the controller 11 in the illustrated embodiment. As would be readily understood by those skilled in the art, other inputs are also contemplated by the present invention and are generally described herein by the term sensor. In addition, an input signal may also be received from a remote transmitter 50 (FIG. 2).

The data communications bus interface 15 of the controller 11 may also preferably be connected to a plurality of output devices. The outputs may include auxiliary relay outputs 30, such as for window control, remote starting, or a remote alarm indication, as would be readily understood by those skilled in the art. A siren and/or lights 31, and green and red light emitting diodes (LEDs) 32, 33 for dashboard mounting are also illustratively connected to the controller 11. Other outputs may be directed to a valet LED 34, a dome light 36, a central lock relay or lock control unit 41, a starter kill circuit 42, and an armed relay output 43. In addition, other outputs may be directed to one or more of an audible tone generator 37, an alphanumeric display 44, a speech message annunciator 45, and a vibration transducer 46, as will be readily appreciated by those skilled in the art. Other similar

-11-

indicating devices are also contemplated by the present invention, as would be readily understood by those skilled in the art. Some of the illustrated devices may be hardwired to various control nodes as would be readily understood by those skilled in the art. The control nodes may be connected by the data communications bus as would also be known to those skilled in the art.

Referring now more particularly to FIG. 2, a remote transmitter 50 in accordance with the invention is described. The remote transmitter 50 illustratively includes a housing 51 and a plurality of first momentary contact switches 52a-52d carried by the housing. A second momentary contact switch 53 and an indicating light, such as the illustrated LED 54 are also carried by or mounted on the housing 51. As would be readily understood by those skilled in the art, the remote transmitter 50 is typically relatively small and includes an opening 55 for facilitating connection to a vehicle key ring, for example. In addition, the remote transmitter 50 includes a central processing unit or microprocessor 56 operatively connected to the plurality of first switches 52a-52d, the second switch 53, and the LED 54. The microprocessor is also connected to a transmitter and/or receiver circuit 57 and its associated antenna 57a for transmitting and/or receiving signals to and from the controller 11 of the vehicle security system 10. Accordingly, the term "remote transmitter" is used broadly herein to describe the embodiment also including receiver means.

The remote transmitter 50 may also include a numeric or alphanumeric display 58, and a speaker 59 coupled to an audible tone generator or a speech

-12-

message generator, as may be provided by the microprocessor 56. A vibration transducer, not shown, may also be incorporated into the remote transmitter 50 for communicating to the user as would be readily understood by those skilled in the art.

Of course, as will be readily appreciated by those skilled in the art, the remote transmitter may be a central station, for example, rather than a handheld unit 50 as shown in FIG. 2. Also the remote transmitter may include a handheld unit that communicates first to a central station. Other forms of remote transmitters are also contemplated by the invention as will be understood by those skilled in the art.

Turning now additionally to FIG. 3 a first embodiment of the desired signal enabling means 17 is described. The vehicle security system 10 preferably comprises a vehicle security sensor and associated sensor bus interface means 60 for interfacing the vehicle security sensor to the data communications bus 62. The vehicle security system 10 also preferably includes an alarm indicator and associated alarm indicator bus interface means 64 for interfacing the alarm indicator to the data communications bus. Examples of vehicle security sensors and alarm indicators are described above in greater detail with reference to FIG. 1.

The security system 10 further preferably comprises desired signal enabling means 17 for enabling the alarm controller 10 to operate using a desired set of signals for a desired vehicle from among a plurality of possible sets of signals for different vehicles. As would be readily understood by those skilled in the art, the term different vehicles may include vehicles from different manufacturers, different models, or even

-13-

different trim levels of the same make and model. Accordingly, the desired signal enabling means 17 permits the alarm controller, that is, the security CPU and bus interface 65, to communicate with the vehicle security sensor and the alarm indicator via the data communications bus 62 so that the CPU is capable of operating the alarm indicator responsive to the vehicle security sensor.

The data communications bus 62 may preferably be a multiplexed data bus as would be readily understood by those skilled in the art. Accordingly, the sensor bus interface means, the alarm bus interface means, and the alarm controller bus interface means may each comprise multiplexing means for interfacing with the multiplexed data bus of the vehicle. For example, any of the various multiplexing schemes as disclosed in "The Thick and Thin of Car Cabling" by Thompson appearing in the IEEE Spectrum, Feb. 1996, pp. 42-45 may be used. Other data bus connection schemes are also contemplated by the present invention.

As illustrated in FIG. 3, one embodiment of the desired signal enabling means 17 may preferably include a memory 70 for storing a plurality of sets 72a, 72b and 72n of signals for different vehicles, and selecting means for selecting the desired set of signals from the plurality of different sets of signals for different vehicles. By storing sets of signals is meant storing information or data necessary to generate the desired signals on the data bus 62 as would be readily understood by those skilled in the art. The memory 70 may include device address memory means for storing a plurality of different sets of signals representative of different device addresses for different vehicles. Alternatively, or in addition thereto, the memory means may comprise protocol memory

-14-

means for storing a plurality of different protocols for different vehicles. One or more other control nodes and associated bus interfaces 66 may also be connected to the data communications bus 62 as would also be readily understood by those skilled in the art. For example, other control nodes may include an engine controller thereby permitting the alarm controller to disable the engine, or the body controller thereby permitting the alarm controller to control the vehicle door locks as would be readily understood by those skilled in the art.

In the illustrated embodiment of FIG. 3, the selecting means may comprise user selecting means 75 for permitting a user to select the desired set of signals. A keypad or other input means may be used to permit the user to select the desired signal set for his vehicle. The valet switch 27 (FIG. 1), for example, may also be operated by the user to select the desired signal set. The user may select the desired set of signals by entering a unique digital code similar to the selection of signals for a home electronics universal remote control. Other techniques for permitting the user to select the desired signal set from a plurality of stored sets are also contemplated by the invention as would be readily appreciated by those skilled in the art.

Referring now additionally to FIG. 4 another embodiment of the desired signal enabling means 17' is described in accordance with the security system 10' of the present invention. In this embodiment, the selecting means may comprise bus determining means 77 for determining the desired set of signals based upon signals on the data communications bus. For example, the bus determining means could determine the desired set of signals based upon sensed voltage levels or based upon the timing of signal pulses on the data

-15-

communications bus 62. The other components of this embodiment of the desired signal enabling means 17' are similar to those described above with reference to FIG. 3 and need no further description.

5 Yet another embodiment of the security system 10" according to the invention is explained with reference to FIG. 5. In this illustrated embodiment the desired signal enabling means 17" includes a desired signal set memory 81 operatively connected to the illustrated bus  
10 learning means 80. The bus learning means 80 may determine and store in the signal set memory 81 the protocol and/or device addresses for the vehicle devices. For example, the bus learning means 80 may permit the user to operate various vehicle devices and  
15 store a desired signal set based thereon as would be readily understood by those skilled in the art. The other components of the desired signal enabling means 17" are similar to those described above with reference to FIG. 3 and need no further description.

20 Still another embodiment of the desired signal enabling means 17'" is explained with reference to FIG. 6A. The desired signal enabling means 17'" includes a signal set memory 81 operatively connected to the schematically illustrated download learning means 84.  
25 The download learning means 84 may include an interface connected to the illustrated vehicle cellular telephone 86 to permit learning or downloading of the desired signal set from a remote or central monitoring and control station 88, for example. The desired signal set  
30 may also alternately be learned from the central station 88 through the satellite link provided by the satellite 110 and vehicle mounted satellite receiver 111 and associated antennas. As would be readily

-16-

understood by those skilled in the art, the download learning means, as well as the other desired signal enabling means may be implemented by software in the CPU 12 of the controller 11 or in a separate

5 microprocessor or circuits.

Turning now additionally to FIG. 6B, another variation of programming, learning or downloading of the download learning means 84 is explained. In this variation the download learning means 84 is temporarily  
10 connected to a computer, such as the illustrated portable laptop computer 115. The connection, may be via a wire cable or wireless communications link as will be readily understood by those skilled in the art. Of course, the desired signal enabling means 17" in  
15 this embodiment may be programmed in the vehicle or prior to installation in the vehicle.

One implementation of the security system 10 is shown in FIG. 7 and includes the vehicle security controller 11. The remote transmitter 50 can switch the  
20 controller 11 between the armed and disarmed modes. The controller 11 in the armed mode is capable of generating an alarm indication via the siren 31 (FIG. 1) and based upon the door switches 25 (FIG. 1), for example. The communications are via the data  
25 communications bus 62, and are based upon the desired signal set from the desired signal enabling means 17.

The features and aspects described above may also be readily implemented into other vehicle related systems, such as for performing remote control  
30 functions. As shown in FIG. 8, the invention may be embodied in a remote keyless entry system 90 including a remote keyless entry controller 91 operated by a remote handheld transmitter 93. The controller 91 communicates with the door lock motors 94 and

-17-

illustrated trunk release 96 via the data communications bus 62. The remote keyless entry system 90 also includes the desired signal enabling means 17 which permits the controller 91 to perform the desired door locking and trunk release remote control functions or operations as would also be readily understood by those skilled in the art. As would be readily appreciated by those skilled in the art, any of the desired signal enabling means described herein and equivalent thereto may be used for the remote keyless entry system 90 in accordance with the present invention.

Turning now to FIG. 9, yet another vehicle associated remote control function is illustrated and now explained. The remote engine starting system 100 includes a remote start controller 101 operable by a remote transmitter 103. The remote controller 101 may communicate via the data communications bus 62 to enable the ignition and fuel systems 106 and crank the engine starter 104. Various sensors may also be monitored as would be readily understood by those skilled in the art.

A method aspect of the invention is for operating a vehicle security system 10 for a vehicle of a type including a data communications bus 62 connecting a plurality of vehicle devices. The method preferably comprises the steps of interfacing an alarm controller 11 to the data communications bus 62, and enabling the alarm controller to operate using a desired set of digital signals for a desired vehicle from a plurality of possible sets of signals for different vehicles to thereby permit the alarm controller to communicate with at least one of a vehicle security sensor 60 and an alarm indicator 64 via the data communications bus 62

-18-

(FIG. 3). Accordingly, the alarm controller is capable of operating the alarm indicator responsive to the vehicle security sensor and via the data communication bus.

5 Another method of the invention is for remotely controlling a vehicle function for a vehicle of a type including a data communications bus 62 connecting a plurality of vehicle devices, and a vehicle function controller and associated bus interface means for  
10 interfacing the vehicle function controller to the data communications bus. The method comprising the steps of: enabling the vehicle function controller to operate using a desired set of signals for a desired vehicle from a plurality of sets of signals for different  
15 vehicles for permitting the vehicle function controller to communicate via the data communications bus with at least one of the vehicle devices; and receiving a signal at the vehicle from a remote transmitter so that the vehicle function controller remotely controls a  
20 vehicle function responsive to the remote transmitter.

Those of skill in the art will readily recognize the benefits and advantages of the present invention for aftermarket security systems and other aftermarket systems for implementing remote control functions  
25 wherein compatibility with a potentially large number of different protocols and/or device addresses is desired. Of course, many modifications and other embodiments of the invention will come to the mind of one skilled in the art having the benefit of the  
30 teachings presented in the foregoing descriptions and the associated drawings. Accordingly, it is understood that the invention is not to be limited to the illustrated embodiments disclosed, and that the modifications and embodiments are intended to be  
35 included within the spirit and scope of the appended claims.

## THAT WHICH IS CLAIMED IS:

1. A vehicle security system (10) for a vehicle of a type including a data communications bus (62) connecting a plurality of vehicle devices (29-46), said vehicle security system comprising, a vehicle  
5 security sensor and associated sensor bus interface means (60) for interfacing said vehicle security sensor to the data communications bus, an alarm indicator and associated alarm indicator bus interface means (64) for  
10 interfacing said alarm indicator to the data communications bus, and an alarm controller and associated alarm controller bus interface means (65) for interfacing said alarm controller to the data communications bus, and characterized that the vehicle security system further comprises:

15           desired signal enabling means (17) for enabling said alarm controller to operate using a desired set of signals for a corresponding desired vehicle from a plurality of sets of signals for different vehicles for permitting said alarm controller  
20 to communicate with said vehicle security sensor and said alarm indicator via the data communications bus so that said alarm controller is capable of operating said alarm indicator responsive to said vehicle security sensor.

25           2. A vehicle security system (10) according to Claim 1 wherein said desired signal enabling means comprises:

          memory means (70) for storing a plurality of sets of signals for different vehicles; and  
30           selecting means for selecting the desired set of signals from the plurality of different sets of signals for different vehicles.

3. A vehicle security system (10) according to Claim 2 wherein said selecting means comprises user selecting means (75) for permitting a user to select the desired set of signals.

5 4. A vehicle security system (10) according to Claim 2 wherein said selecting means comprises bus determining means (77) for determining the desired set of signals based upon signals on the data communications bus (62).

10 5. A vehicle security system (10) according to Claim 2 wherein said memory means (70) comprises device address memory means (72a-72n) for storing a plurality of different sets of signals for different device addresses.

15 6. A vehicle security system (10) according to Claim 2 wherein said memory means (70) comprises protocol memory means (72a-72n) for storing a plurality of different sets of signals for different protocols.

20 7. A vehicle security system (10) according to Claim 1 wherein said desired signal enabling means (17) comprises bus learning means (80) for learning the desired set of signals based upon signals on the data communications bus (62).

25 8. A vehicle security system (10) according to Claim 1 wherein said desired signal enabling means (17) comprises download learning means (84) for learning the desired set of signals from a downloading device (86).

30 9. A vehicle security system (10) according to Claim 8 wherein said downloading learning means (84) comprises means for learning the desired set of signals from a computer (115) temporarily connected thereto.

35 10. A vehicle security system (10) according to Claim 1 wherein said desired signal enabling means (17) comprises protocol providing means (81) for providing a protocol for the desired vehicle.

11. A vehicle security system (10) according to Claim 1 wherein said desired signal enabling means (17) comprises device address providing means (81) for providing device addresses for the desired vehicle.

5 12. A vehicle security system (10) according to Claim 1 further comprising a vehicle controller (11) and associated vehicle controller bus interface means for connecting the vehicle controller to the data communications bus; and wherein said alarm controller  
10 (65) is operatively connected to said vehicle controller.

13. A vehicle security system (10) according to Claim 1 wherein the data communications bus (62) is a multiplexed data bus; and wherein the sensor bus  
15 interface means (60), the alarm bus interface means (64), and the alarm controller bus interface means (65) each comprises multiplex interface means for interfacing with the multiplexed data bus.

14. A vehicle security system (10) according  
20 to Claim 1 wherein said vehicle security sensor (60) comprises one of a door switch (25), a trunk switch (23), a proximity sensor, and a motion sensor.

15. A vehicle security system (10) according to Claim 1 wherein said alarm indicator (64) comprises  
25 one of a vehicle light (31), a vehicle horn, a siren (31), a speech message generator (45), and a remote pager (35).

16. A remote control system for a vehicle of a type including a data communications bus (62)  
30 connecting a plurality of vehicle devices (20-46), the remote control system comprising a remote transmitter (50), a receiver (13) within the vehicle for receiving a signal from the remote transmitter, a vehicle function controller (11) operatively connected to the  
35 receiver, and associated vehicle function controller bus interface means (15) for interfacing the vehicle function controller to the data communications bus, and

characterized that the remote control system further comprises:

desired signal enabling means (17) for enabling said vehicle function controller to operate  
5 using a desired set of signals for a corresponding desired vehicle from a plurality of sets of signals for different vehicles for permitting said vehicle function controller to communicate via the data communications bus with a vehicle device so that said vehicle function  
10 controller is capable of operating the vehicle device responsive to said remote transmitter.

17. A remote control system for a vehicle according to Claim 16 wherein the plurality of vehicle devices (20-46) comprises a vehicle security sensor and  
15 associated sensor bus interface means (60) for interfacing said vehicle security sensor to the data communications bus (62); and wherein said vehicle function controller (11) comprises an alarm controller (65) being capable of generating an alarm responsive to  
20 the vehicle security sensor.

18. A remote control system for a vehicle according to Claim 16 wherein the plurality of vehicle devices (20-46) comprises a plurality of vehicle door locks (25) movable between locked and unlocked  
25 positions and associated bus interface means for interfacing said door locks to the data communications bus (62); and wherein said vehicle function controller (11) comprises a door lock controller for moving the vehicle door locks between locked and unlocked  
30 positions responsive to said remote transmitter (50).

19. A remote control system for a vehicle according to Claim 16 where said plurality of vehicle devices (20-46) comprises vehicle engine starting means and associated bus interface means (104) for  
35 interfacing said vehicle engine starting means to the data communications bus; and wherein said vehicle function controller (11) comprises a remote start controller (101) for operating the vehicle engine

starting means responsive to said remote transmitter (50).

20. A remote control system for a vehicle according to Claim 16 wherein said desired signal enabling means (17) comprises:

memory means (70) for storing a plurality of sets of signals for different vehicles; and

selecting means for selecting the desired set of signals from the plurality of different sets of signals for different vehicles.

21. A remote control system for a vehicle according to Claim 20 wherein said selecting means comprises user selecting means (75) for permitting a user to select the desired set of signals.

22. A remote control system for a vehicle according to Claim 20 wherein said selecting means comprises determining means (77) for determining the desired set of signals based upon signals on the data communications bus (62).

23. A remote control system for a vehicle according to Claim 20 wherein said memory means (70) comprises address memory means (72a-72n) for storing a plurality of different sets of digital signals for different device addresses.

24. A remote control system for a vehicle according to Claim 20 wherein said memory means (70) comprises protocol memory means (72a-72n) for storing a plurality of different sets of signals for different protocols.

25. A remote control system for a vehicle according to Claim 16 wherein said desired signal enabling means (17) comprises learning means (80) for learning the desired set of signals.

26. A remote control system for a vehicle according to Claim 16 wherein said desired signal enabling means (17) comprises protocol providing means (81) for providing a protocol for the desired vehicle.

27. A remote control system for a vehicle according to Claim 16 herein said desired signal enabling means (17) comprises device address providing means (81) for providing device addresses for the  
5 desired vehicle.

28. A remote control system for a vehicle according to Claim 16 further comprising a second vehicle controller (11) and associated vehicle controller bus interface means for connecting to the  
10 data communications bus (62); and wherein said vehicle function controller is operatively connected to said second vehicle controller.

29. A remote control system for a vehicle according to Claim 16 wherein the data communications  
15 bus (62) is a multiplexed data bus; and wherein the vehicle function controller bus interface means (15) comprises multiplexing means for interfacing with the multiplexed data bus.

30. A method for remotely controlling a  
20 vehicle function for a vehicle of a type including a data communications bus (62) connecting a plurality of vehicle devices (20-46), and a vehicle function controller (11) and associated bus interface means (15) for interfacing the vehicle function controller to the  
25 data communications bus; the method comprising the steps of receiving a signal at the vehicle from a remote transmitter (50) so that the vehicle function controller remotely controls a vehicle function responsive to the remote transmitter, and characterized  
30 that the method further comprises:

enabling the vehicle function controller to operate using a desired set of signals for a corresponding desired vehicle from a plurality of sets of signals for different vehicles for permitting the  
35 vehicle function controller to communicate via the data communications bus with at least one of the vehicle devices.

-22-

31. A method according to Claim 30 wherein the plurality of vehicle devices (20-46) comprises a vehicle security sensor and associated sensor bus interface means (60) for interfacing the vehicle security sensor to the data communications bus (62);  
5 wherein the vehicle function controller (11) comprises an alarm controller (65) movable between armed and disarmed modes, the alarm controller when in the armed mode being capable of generating an alarm indication  
10 responsive to the vehicle security sensor; and wherein the step of receiving comprises receiving a signal so that the vehicle function controller is moved to one of the armed and disarmed modes.

32. A method according to Claim 30 wherein  
15 the plurality of vehicle devices (20-46) comprises a plurality of vehicle door locks (25) movable between locked and unlocked positions and associated bus interface means for interfacing the door locks to the data communications bus (62); and wherein the step of  
20 receiving comprises moving the vehicle door locks to one of locked and unlocked positions responsive to the remote transmitter (50).

33. A method according to Claim 30 wherein  
25 the plurality of vehicle devices (20-46) comprises vehicle engine starting means and associated bus interface means (104) for interfacing the vehicle engine starting means to the data communications bus (62); and wherein the step of receiving comprises  
30 operating the vehicle engine starting means responsive to the remote transmitter (50).

34. A method according to Claim 30 wherein the step of enabling the vehicle function controller (11) to operate using a set of desired signals comprises the steps of:

35 storing in a memory (70) a plurality of sets of signals for different vehicles; and

selecting the desired set of signals from the plurality of different sets of signals for different vehicles.

35. A method according to Claim 34 wherein  
5 the step of selecting comprises permitting user selection of the desired set of signals.

36. A method according to Claim 34 wherein  
the step of selecting comprises determining the desired set of signals based upon signals on the data  
10 communications bus (62).

37. A method according to Claim 34 wherein  
the step of storing in memory (70) comprises storing a plurality of different sets of signals representative of different device addresses.

15 38. A method according to Claim 34 wherein  
the step of storing in memory (70) comprises storing a plurality of different sets of signals representative of different protocols.

39. A method according to Claim 30 wherein  
20 the step of enabling the vehicle function controller (11) to operate using a set of desired signals comprises the step of learning the desired set of signals.

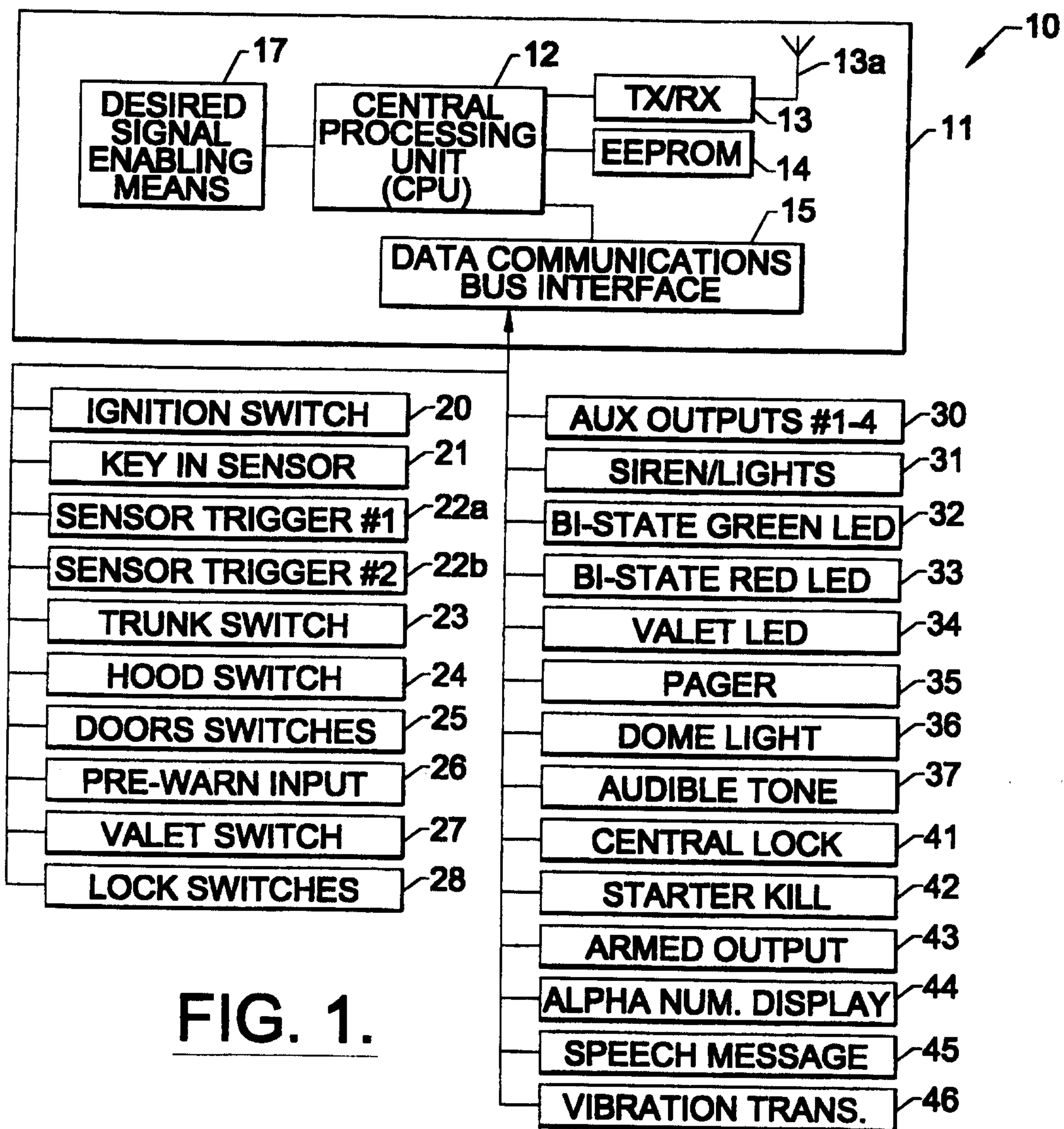

FIG. 1.

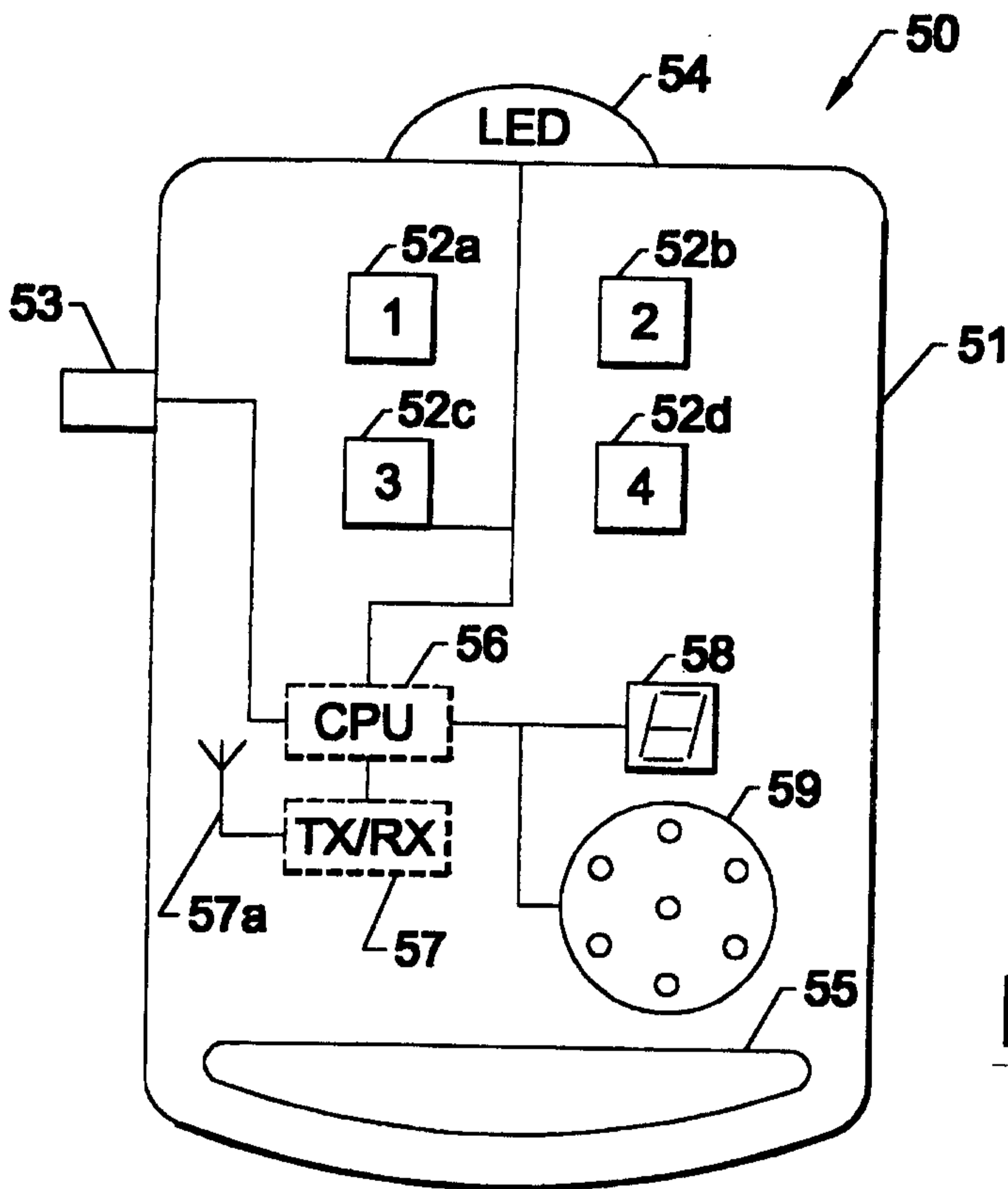

FIG. 2.

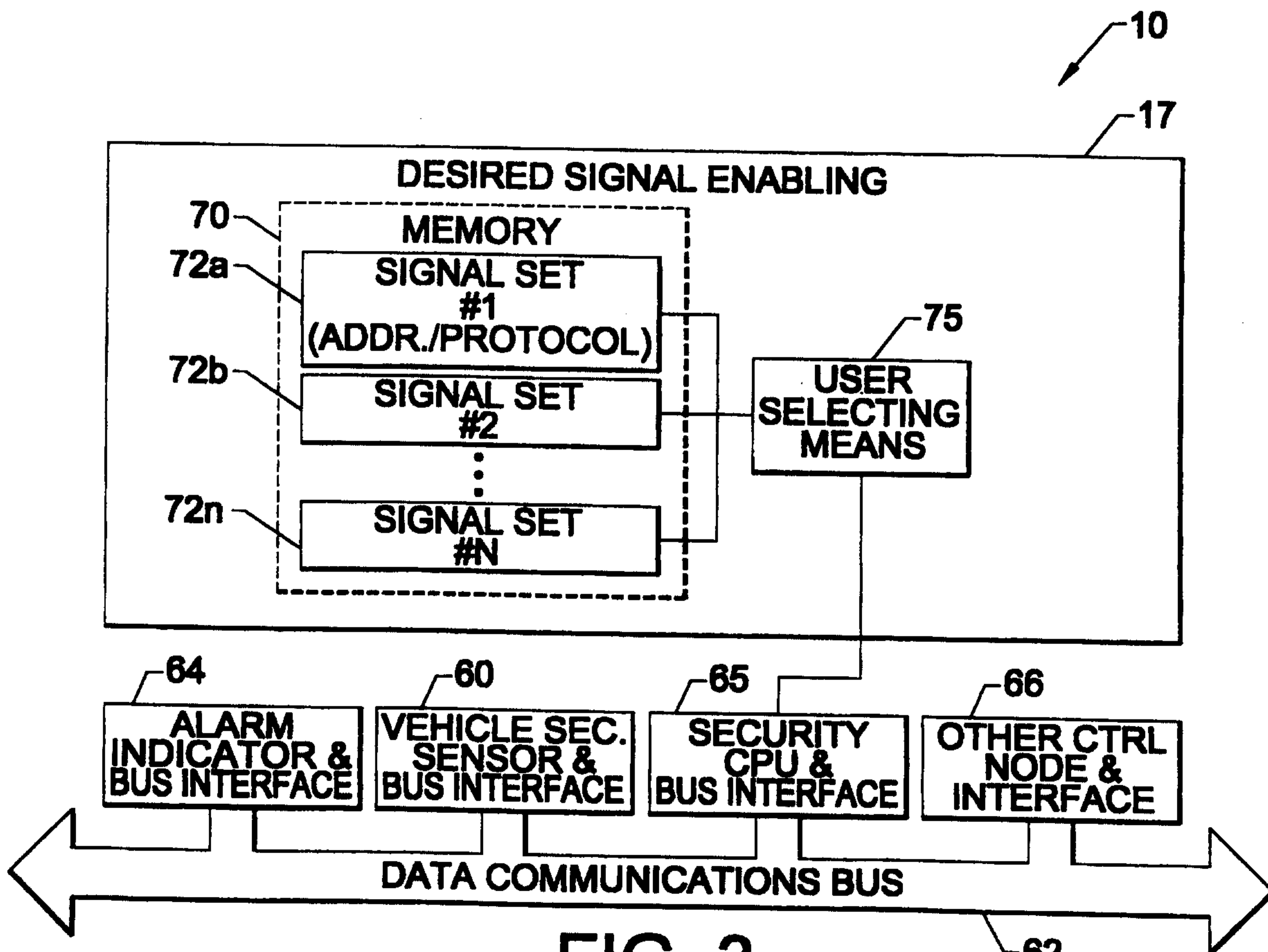

FIG. 3.

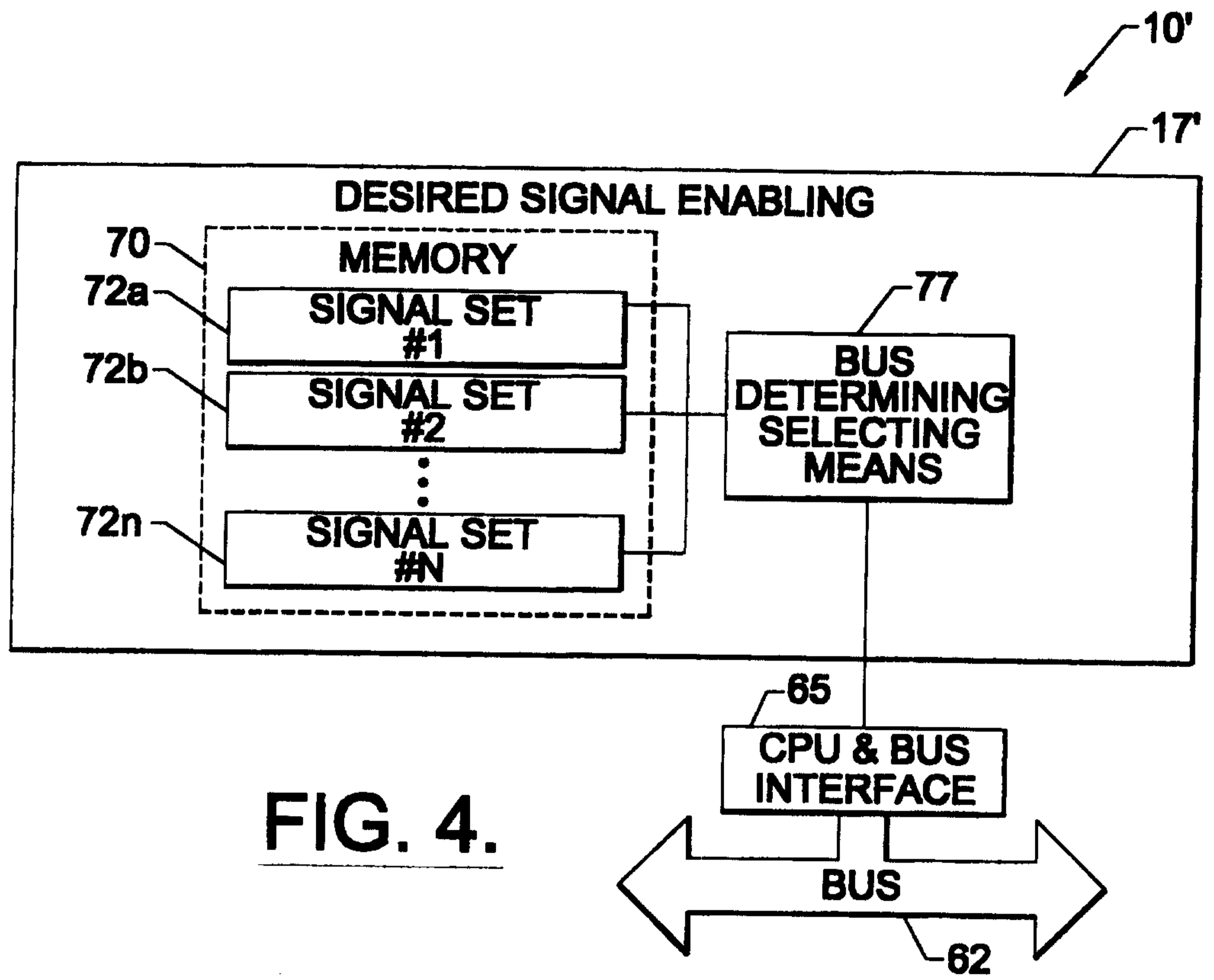

FIG. 4.

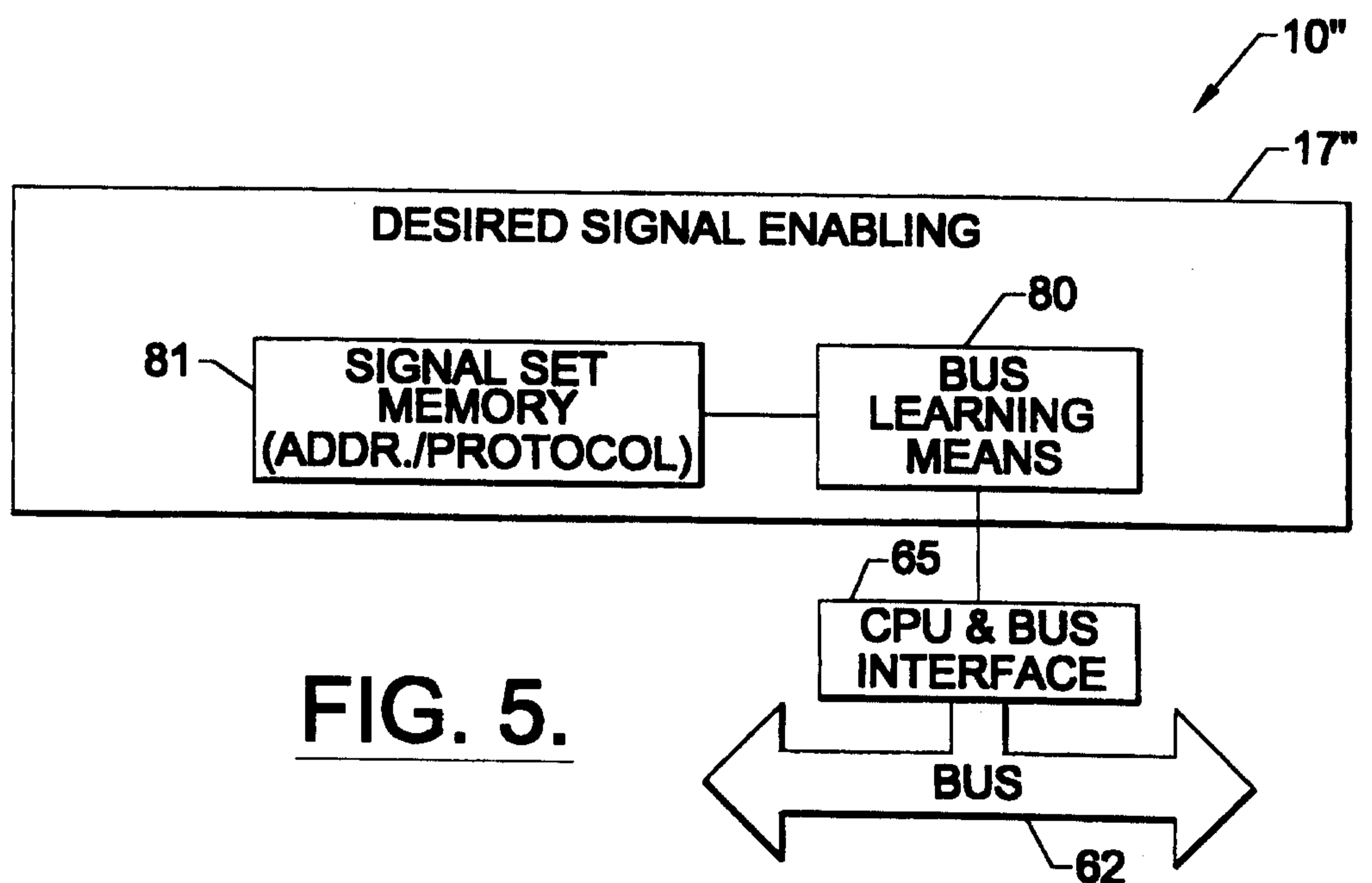

FIG. 5.

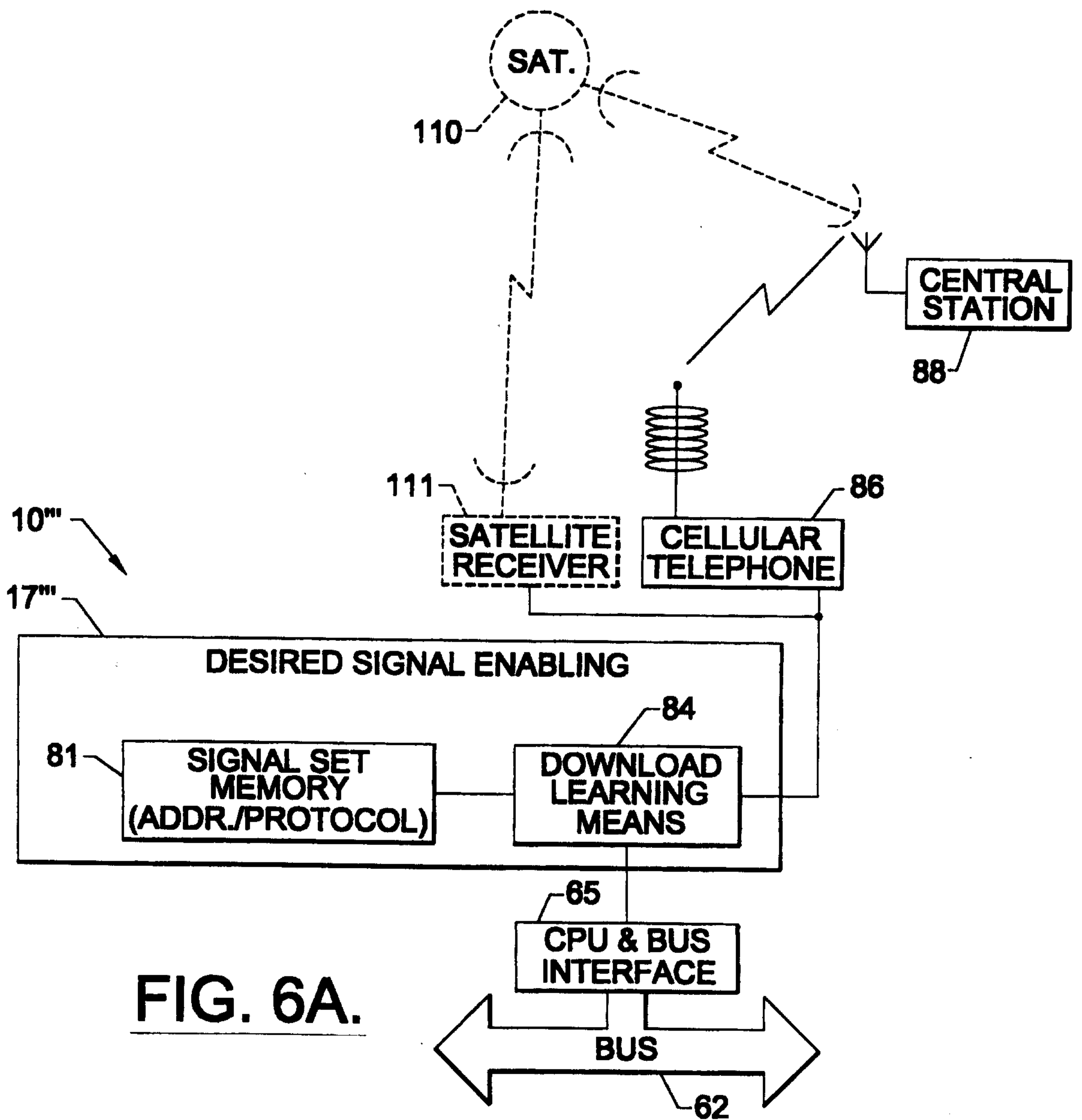

FIG. 6A.

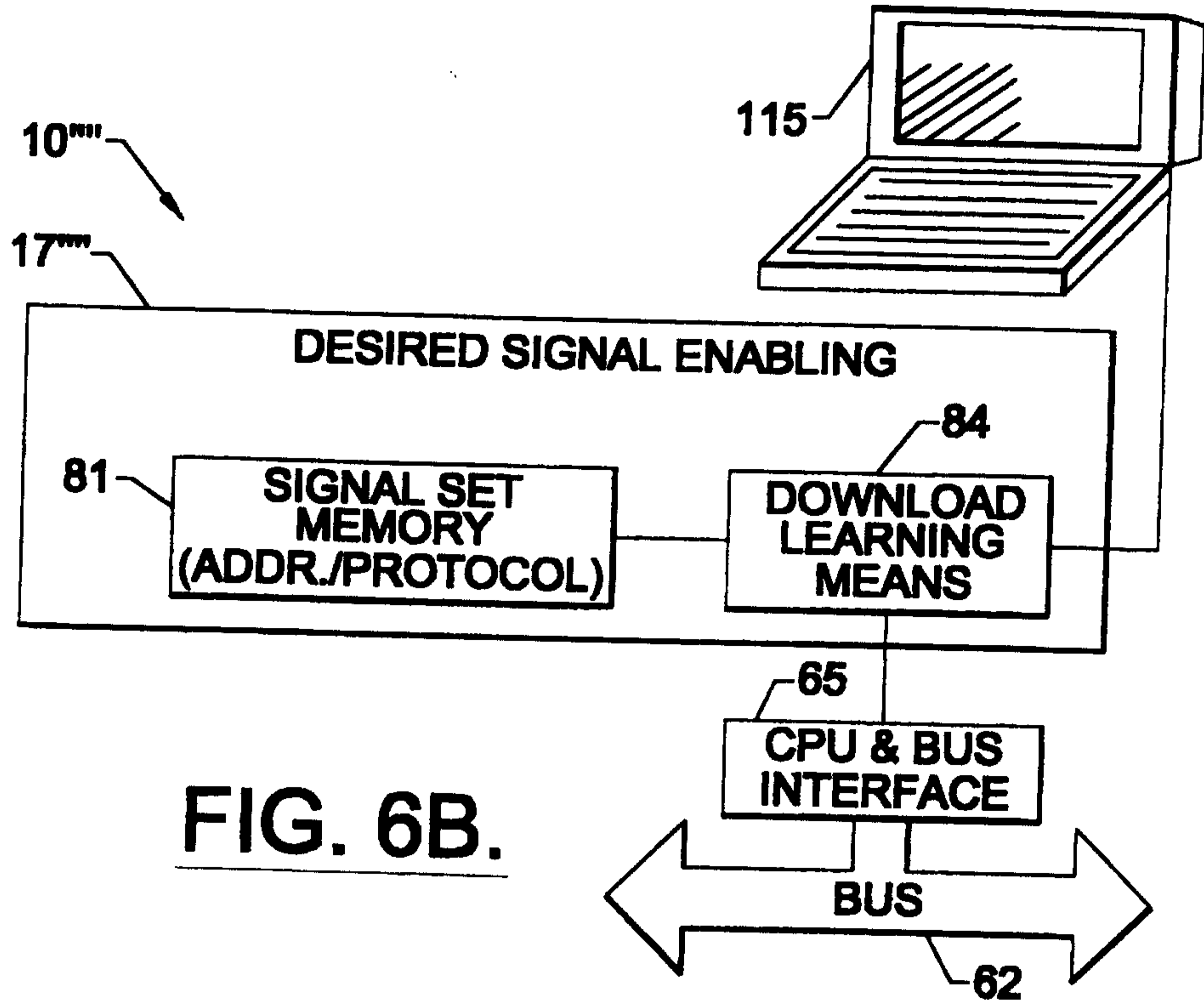

FIG. 6B.

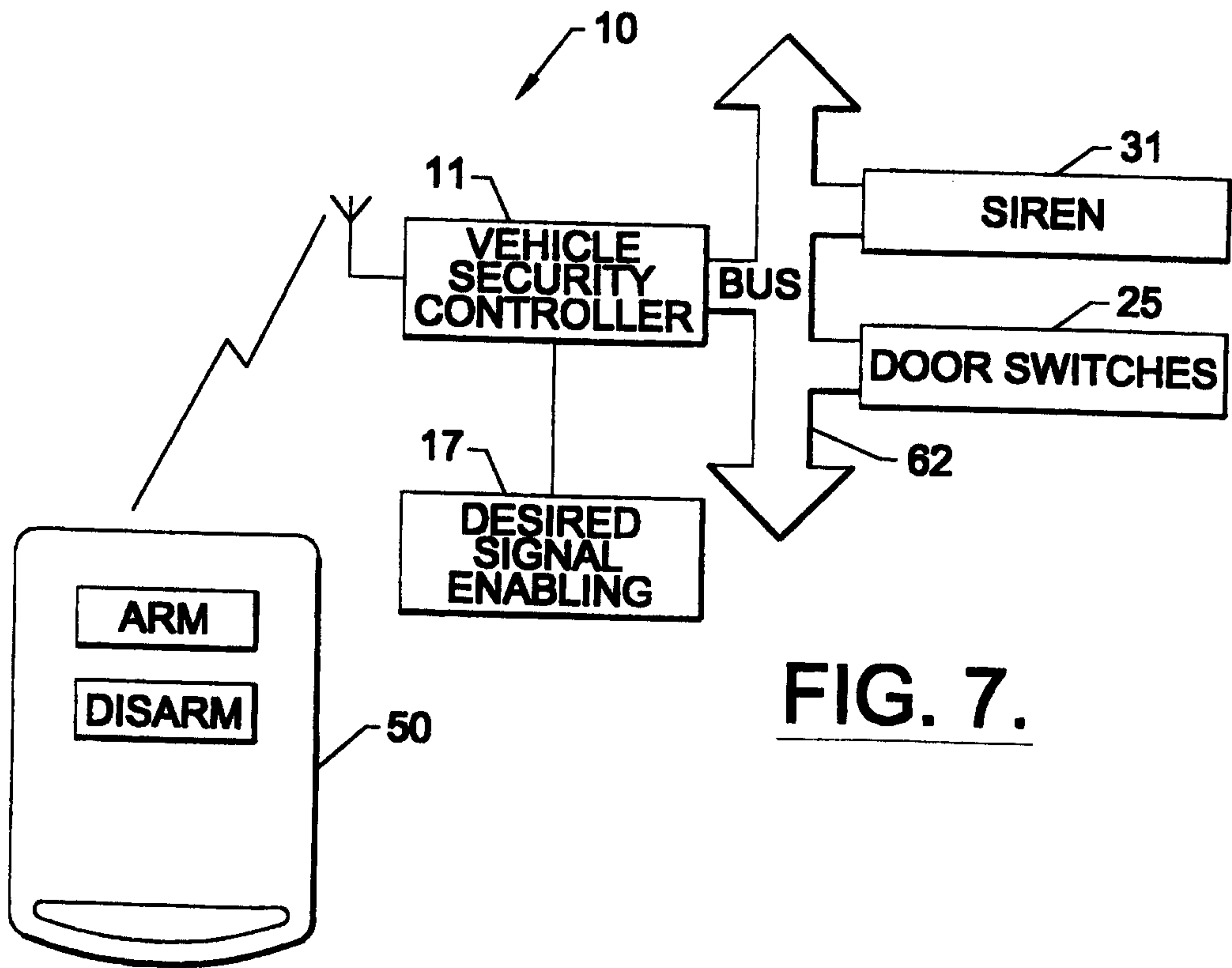

FIG. 7.

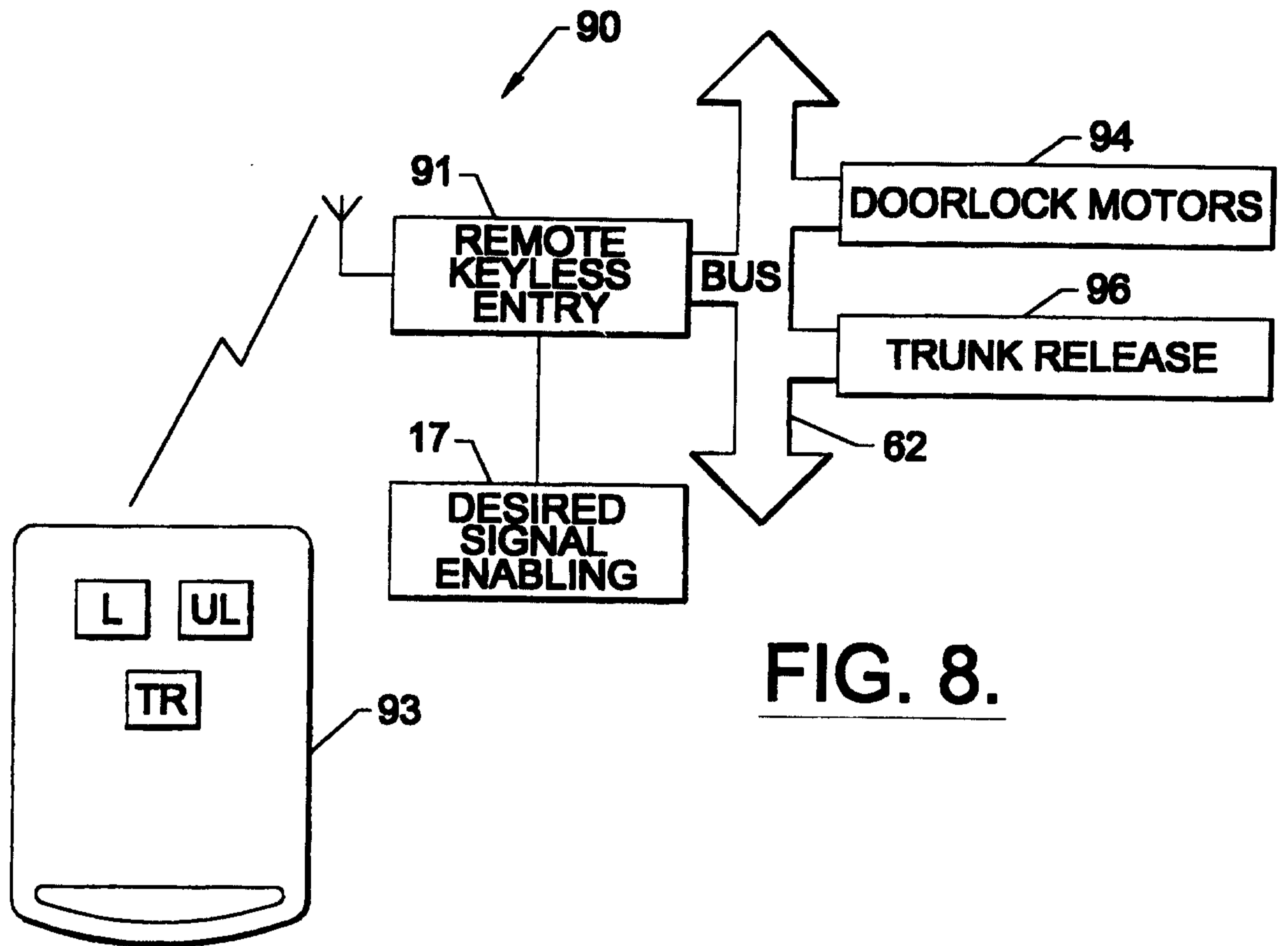

FIG. 8.

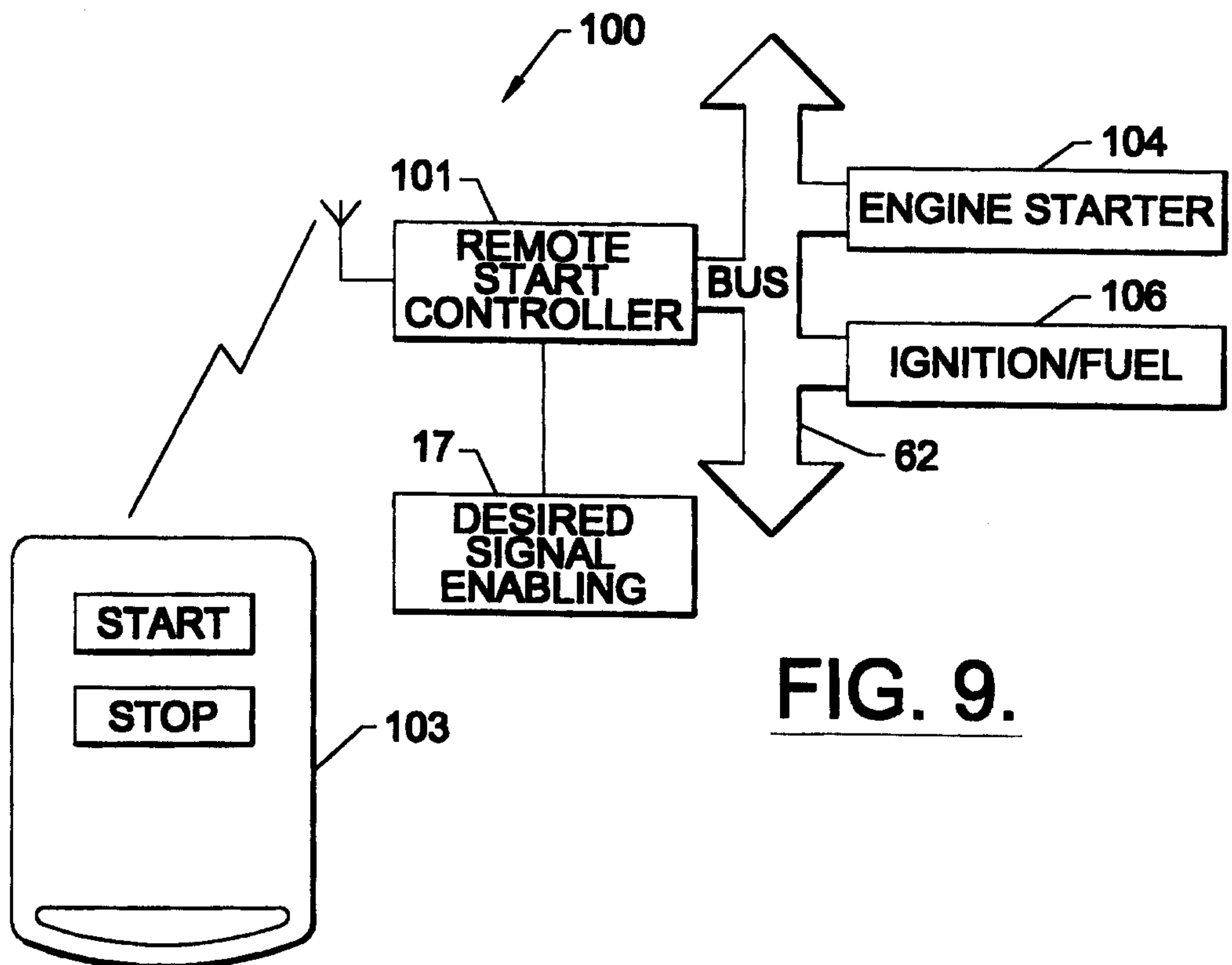

FIG. 9.

