

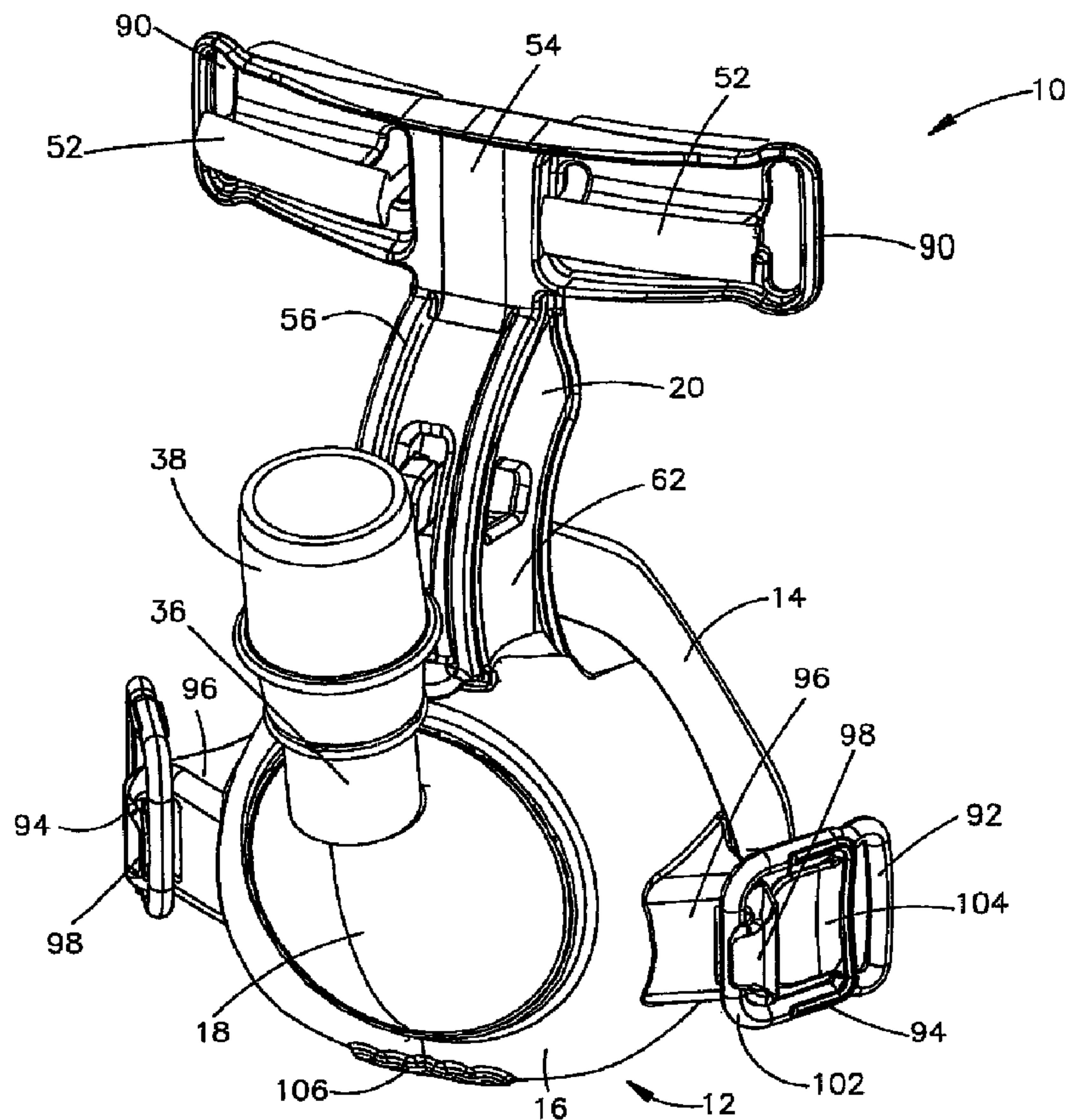

(22) Date de dépôt/Filing Date: 2003/03/22  
 (41) Mise à la disp. pub./Open to Public Insp.: 2003/10/09  
 (62) Demande originale/Original Application: 2 469 318  
 (30) Priorité/Priority: 2002/03/22 (US60/366,934)

(51) Cl.Int./Int.Cl. *A61M 16/06* (2006.01)  
 (71) Demandeur/Applicant:  
 INVACARE CORPORATION, US  
 (72) Inventeurs/Inventors:  
 ROSENKRANZ, MARK E., US;  
 SPRINKLE, TOM, US;  
 WHITESEL, MARY B., US  
 (74) Agent: OSLER, HOSKIN & HARCOURT LLP

(54) Titre : MASQUE NASAL  
 (54) Title: NASAL MASK



(57) **Abrégé/Abstract:**

A nasal mask assembly for preferred use in CPAP treatment. The mask assembly comprises a central body, a face cushion, a forehead support and a gas inlet. The gas inlet is rotatably connected to the central body, and the forehead support is pivotally connected to the central body. A method of using such a mask is also provided.

Abstract

A nasal mask assembly for preferred use in CPAP treatment. The mask assembly comprises a central body, a face cushion, a forehead support and a gas inlet. The gas inlet is rotatably connected to the central body, and the forehead support is pivotally connected to the central body. A method of using such a mask is also provided.

## NASAL MASK

### Background and Summary of the Invention

[0002] This invention pertains to a nasal mask. Nasal masks may be used to deliver gases of controlled composition, at a controlled pressure, and at a controlled flow to a person's nasal passages for inhalation. Gas composition typically is controlled to achieve a particular medical goal, such as anesthesiology. Gas pressure typically is controlled to ease or assist the breathing process, made difficult for example due to high altitude or a medical condition afflicting the user.

[0003] The nasal mask described here is particularly useful with continuous positive airway pressure ("CPAP") treatment for sleep disorders, such as obstructive sleep apnea. Pursuant to this treatment the user wears a nasal mask while sleeping. As will be readily understood by one of ordinary skill in the art, a device delivers air to the nasal mask at a pressure above atmospheric pressure. This helps the user to breathe more normally during sleep. Further descriptions of CPAP treatments and devices can be found in U.S. Patent Nos. 5,199,424 and 5,433,193, which are hereby fully incorporated by reference. The mask may be used in the home as well as institutional settings such as long term care facilities.

[0004] The nasal mask described here also is particularly useful in a bi-level or non-invasive ventilator. As a preferred embodiment it may be used to treat chronic obstructive pulmonary disease (COPD), congested heart failure (CHF), and / or gastro esophageal reflux disorder (GERD).

[0005] The nasal mask described here has a lower profile than prior art masks. This has several advantages. It allows less restricted head movement by the user, permits quicker and less expensive manufacturing, and provides a better aesthetic appearance. One or more of these

advantages may encourage treatment compliance by persons who may benefit from treatment requiring use of nasal masks.

[0006] The nasal mask described here further has an improved forehead cushion support. The position of the forehead cushion support is variable, so that a single mask may fit different persons with differently sloping foreheads. This variability permits a single mask design to fit several different persons, thus obviating to some extent the need for making masks of differing sizes. The forehead cushions also are removable from their support to allow more easy and better cleaning, as well as easy replacement. They are nonetheless attached securely to prevent them falling off unintentionally.

#### Description of the Figures

[0007] Figure 1 shows a perspective view of a nasal mask assembly.

[0008] Figure 2 shows a front perspective view of the nasal mask assembly shown in Figure 1 with the component parts disassembled.

[0009] Figure 3 shows a rear perspective view of the nasal mask assembly shown in Figure 1 with the component parts disassembled.

[0010] Figure 4 shows a side view of a gas inlet for use in a nasal mask assembly.

[0011] Figure 5 shows a front view of a gas inlet for use in a nasal mask assembly.

[0012] Figure 6 shows a cross-sectional front view of a gas inlet for use in a nasal mask assembly, taken along line A-A of Figure 5.

[0013] Figure 7 shows a bottom view of a gas inlet for use in a nasal mask assembly.

[0014] Figure 8 shows a detail of Figure 6, as indicated by line F in Figure 6.

[0015] Figure 9 shows a side view of a rotation fitting for use in a nasal mask assembly.

[0016] Figure 10 shows a top view of a rotation fitting for use in a nasal mask assembly.

[0017] Figure 11 shows a cross-sectional view of a rotation fitting for use in a nasal mask assembly, taken along line A-A in Figure 10.

[0018] Figure 12 shows a front view of a forehead frame for use in a nasal mask assembly.

[0019] Figure 13 shows a bottom view of a forehead frame for use in a nasal mask assembly.

[0020] Figure 14 shows a rear view of a forehead frame for use in a nasal mask assembly.

[0021] Figure 15 shows a side view of a forehead frame for use in a nasal mask assembly.

[0022] Figure 16 shows a cross-sectional view of a forehead frame for use in a nasal mask assembly, taken along line A-A of Figure 12.

[0023] Figure 17 shows a cross-sectional view of a forehead frame for use in a nasal mask assembly, taken along line D-D of Figure 15.

[0024] Figure 18 shows a perspective view of a forehead cushion for use in a nasal mask assembly.

[0025] Figure 19 shows a side view of a forehead cushion for use in a nasal mask assembly.

[0026] Figure 20 shows a side view of a forehead cushion for use in a nasal mask assembly.

[0027] Figure 21 shows a front view of a central body for use in a nasal mask assembly.

[0028] Figure 22 shows a side view of a central body for use in a nasal mask assembly.

[0029] Figure 23 shows a rear view of a central body for use in a nasal mask assembly.

[0030] Figure 24 shows a front view of a face cushion for use in a nasal mask assembly.

[0031] Figure 25 shows a side view of a face cushion for use in a nasal mask assembly.

[0032] Figure 26 shows a top view of a face cushion for use in a nasal mask assembly.

[0033] Figure 27 shows a side view of a face cushion for use in a nasal mask assembly.

[0034] Figure 28 shows a rear view of a face cushion for use in a nasal mask assembly.

[0035] Figure 29 shows a cross-sectional view of a face cushion for use in a nasal mask assembly, taken along line B-B of Figure 27.

[0036] Figure 30 shows a detail of Figure 31, as indicated by line H in Figure 31.

[0037] Figure 31 shows a cross-sectional view of a face cushion for use in a nasal mask assembly, taken along line A-A of Figure 26.

Figure 32 shows a plan view of a strap attachment for use in a nasal mask assembly.

Figure 33 shows a sectional view of the strap attachment of Figure 32, taken along line C-C of Figure 32.

Figure 34 shows another sectional view of the strap attachment of Figure 32, taken along line B-B of Figure 32.

Figures 35 and 36 show views of a strap arm for use in a nasal mask assembly.

### Written Description of Preferred Embodiments

[0038] A preferred nasal mask assembly 10 is shown in the accompanying drawings, with Figures 1-3 showing the entire assembly as a whole and the remaining Figures detailing the particular parts. The nasal mask 10 has two main components, a shell 12 and a face cushion 14. The shell component 12 is preferably made of plastic, which is preferably optically transparent. The plastic should be impermeable to gas or air. The shell component 12 has several parts, including a central body 16, a gas inlet 18 and a forehead support 20.

[0039] The central body 16 defines a central cavity 22. A circular inlet aperture 24 in the front of the central body 16 permits air to enter the central cavity 22. The gas inlet 18 is rotatably attached to the central body 16 so that it covers the circular aperture 24. One of ordinary skill in the art will know several methods of rotatably attaching the gas inlet 18 over the circular aperture 24.

[0040] In the embodiment shown in Figures 4-8, for example, the gas inlet 18 defines a circular edge portion 26 having several flanges 30, each with a groove 28. The flanges 30 along the circular edge portion 26 extend into the central cavity 22 of the central body 16. The central body rim 32, which defines the circular aperture 24, snaps in behind the grooves 28 of the flanges 30, thereby sealing against the release of air from within the cavity 22 or gas inlet 18 to the outside environment.

[0041] The gas inlet 18 extends to a cylindrical tube portion 36 having a tube axis T, oriented with respect to the center axis C of the gas inlet 18 at a tube angle A. Where the tube portion 36 extends parallel to the circular aperture's center axis C the tube angle A is zero (0) degrees. Where the tube portion 36 extends perpendicular to the circular aperture's center axis C the tube angle A is ninety (90) degrees. The tube angle A of the nasal mask 10 may be anywhere from between about 0 and about 130 degrees. The upper limit for the tube angle A is dictated solely by the need to avoid the tube (not shown in drawings) interrupting head movement as much as possible. The tube angle A is preferably between 0 and about 90 degrees, more preferably between about 60 and about 90 degrees, and most preferably between about 75 and about 90 degrees. That preferred range permits the tube portion 36 to be made with a relatively lower profile than is available in the prior art.

[0042] The cylindrical tube portion 36 connects to a flexible gas delivery tube (not shown in the drawings) in such a way that the tube may rotate with respect to the cylindrical tube

portion 36. One of ordinary skill in the art will know of various suitable rotatable connections. For example, Figures 9-11 show a rotation fitting 38 for connecting the tube to the tube portion 36. The rotation fitting 38 has two cylindrical portions, one having a smaller diameter 37 than the other 39, thereby defining an interior shelf 40 within the rotation fitting 38. The cylindrical tube portion 36 may exhibit a fitting ring 44 at its end for snap fitting within the interior shelf 40 of the rotation fitting 38. Or, the cylindrical tube portion 36 may alternatively exhibit several flanged projections 42 (not shown in the drawings), similar to the flanges 30 of the gas inlet 18, for providing a snap fit with the rotation fitting 38. The cylindrical tube portion 36 may further have an external ring 46. The smaller diameter portion 37 of the rotation fitting 38 slides on to the tube portion 36 of the mask 10 until it abuts the external ring 46. At that point either the fitting ring 44 just barely projects into the larger diameter 39 portion of the rotation fitting 38, and snaps out on to the interior shelf 40. The fitting ring 44 therefore keep the rotation fitting 38 from sliding off of the tube portion 36, but also permits rotational movement between the elements. The tube then slides on to the larger diameter portion 39 of the rotation fitting 38, preferably stopped by a tube ring 41, and is held there by frictional forces.

[0043] The nasal mask 10 includes a forehead support 20 comprising a forehead frame 50 and forehead cushions 52. The forehead frame 50, as shown for example in Figures 12-17, has a horizontal member 54, on which the forehead cushions 52 are mounted, and a vertical member 56. The forehead cushions 52, shown in Figures 18-20, are mounted on the horizontal member 54 in a removable manner. One example of a removable mount is shown in the drawings as raised walls 57 in the horizontal member 54 slidably receiving grooved ends 59 of a cushion 52. A cushion 52 may be removed from the horizontal member 54 by sliding it toward a vertical slot 90 at the end of the horizontal member 54. A ramp 58 adjacent the slot 90 permits easy removal of the forehead cushion 52 without allowing the forehead cushion 52 to unintentionally be removed. One of ordinary skill will know of other ways to attach a forehead cushion 52 to a supporting frame 50 in a removable manner.

[0044] The forehead cushions 52 are preferably made of a bio-friendly material such as silicone. The cushion may have internal ribs 55 of various configurations (two are shown in the drawings) to impart sufficiently flexible support. While two cushions 52 are shown in the drawings, any number of cushions 52 may be used in practice, for example 1, 3, 4 or more. Or no cushions may be used.



[0045] The vertical member 56 of the forehead frame 50 attaches to the central body 16 of the nasal mask 10. The vertical member 56 has two arcuate grooves 60, one in each side. Two arms 62, preferably arcuate in shape, extend from the top of the central body 16 as shown in Figures 21-23. Each arm 62 has an inwardly extending ridge 64 for mating with a groove 60 in the vertical member 56 of the forehead support 20. This arcuate ridge-in-groove attachment permits the forehead frame 50 to pivot with respect to the central body 16, thereby accommodating user foreheads of differing slope.

[0046] The nasal mask 10 may include structure for maintaining the forehead support 20 at one of two or more discrete positions relative to the central body 16. One of ordinary skill in the art will know of many ways to do this. For example, the drawings show a positioning arm 66 extending from the central body 16, between the two arms 62. The positioning arm 66 may alternatively, or in addition, extend from one or both arms 62. The positioning arm 66 has two projections 68, which each may mate with one or more dips 70 in the underside of the forehead frame vertical member 56. Each dip 70 represents a discrete position of the forehead frame 50 with respect to the central body 16. The positioning arm 66 is flexible to permit bending the arm 66 down so that the projections 68 exit a dip 70, and the forehead support 20 may be shifted to another position.

[0047] The nasal mask 10 may further include structure for stopping the forehead support 48 at two extreme positions with respect to the central body 16. There are several ways to do this, as will be known to one of ordinary skill in the art. In the embodiment shown in the drawings, a central tab 72 extends from the positioning arm 66 and into an aperture 74 in the vertical member 56 of the forehead frame 50. The forehead frame 50 reaches one of its two extreme positions when the tab 72 reaches the upper or lower end of the aperture 74.

[0048] A preferred face cushion component 14 for the mask 10 is shown in Figures 24-31. The face cushion 14 serves two basic functions: user comfort and sealing. Thus the face cushion 14 should be made of a bio-friendly elastomeric material which is both substantially gas impermeable and elastic enough to conform comfortably to the contours of a person's face. A preferred material is silicone. The face cushion 14 may take any shape; the shape shown in the drawings is preferred.

[0049] The face cushion 14 comprises a cushion body 76 having two opposed openings, a mask-side or "front" opening 78 and a face-side or "rear" opening 80. The front rim

82 defining the front opening 78 sealingly fits into the rear of the shell's central body 16 in any one of several ways which will be known to one of ordinary skill in the art. Figure 3, for example, shows a brace 84 supported within the central body 16 by several posts 86 (six are shown in the Figures). The brace 84 is shaped to conform to the contour of the central body's 16 rear rim 87, leaving sufficient space between them such that the front rim 82 of the cushion 14 snugly (and substantially air-tightly) fits into the space. Thus the brace 84 acts to secure the cushion 14 to the central body 16.

[0050] The cushion body 76 extends from the front rim 82 to the rear rim 88. The cushion body 76 is sufficiently long that its elastomeric properties can provide a cushioning effect between the nasal mask 10 and the user's face when the mask 10 is worn, but not so long to make the mask 10 cumbersome to use during sleep. The cushion body 76 is sufficiently thick to provide cushioning and to prevent deformation due to pressure on the nasal mask 10 when tightened down on to the user's head.

[0051] The rear opening 80 of the face cushion 14 is defined by a double rim 88. An inner 88a and outer 88b rim extend inwardly from the cushion body 76. The outer rim 88b is relatively thin so that it may more easily conform to the contours of different persons' faces. Pressurized air entering the mask 10 from the tube sealingly presses the outer rim 88b against the user's face. The inner rim 88a is thicker than the outer rim 88b to provide better support for the mask 10 against the user's face, but preferably is thin enough to provide for some adjustment against the contours of the user's face.

[0052] For the most efficient operation, the nasal mask 10 should be held against the user's face. This ensures a sufficiently tight seal so that an elevated pressure is maintained within the mask 10 and the gas delivered to the mask 10 does not leak to the outside environment. The mask 10 may be held against the user's face by hand, but that is generally not satisfactory over long periods of time.

[0053] Therefore the nasal mask 10 may include strap slots 92 for attaching straps (not shown) to the mask 10. A strap end may be looped through a strap slot 92 and then secured, preferably with a snap or hook and loop connection. The strap then may be wrapped around the user's head and adjusted to provide a tight enough fit for maintaining a proper seal, but loose enough for the comfort of the user. The strap slots 92 are preferably located on opposite sides of the central body 16, and perhaps on opposite sides of the horizontal member 54 of the forehead

support 20 (for example, slots 90 may be used as strap slots in addition to providing a sliding entry for the cushions 52). One of ordinary skill in the art will know of several alternatives.

[0054] The strap slots 92 may be formed integrally with a portion of the nasal mask shell 12, such as illustrated in the drawings of the slot 90. Alternatively the strap slots 92 may be part of a strap attachment 94, such as illustrated in Figure 1 and Figures 32-36. The strap attachment 94 slips over a strap arm 96 on the central body 16. A holder 98 on the strap arm 96 projects up into an aperture 100 in the strap attachment 94. Thus the holder fits over and around a holder bar 102, as shown in Figure 1. A flexible tab 104 prevents the holder 98 from exiting the aperture 100 unless and until the strap attachment 94 is rotated around the holder 98 far enough that the flexible tab 104 snaps off of the holder 98 by flexing around to the front of the holder 98. Use of the strap attachment 94 permits the strap to be easily attached to and detached from the central body 16, with a minimal risk that the strap will be accidentally detached as the user rolls around during sleep.

[0055] The nasal mask 10 disclosed herein may be used in the following manner. First the user puts the mask 10 on his or her head and adjusts the head straps to achieve a comfortable but sealingly tight fit. A machine operates to supply air of a desired composition and pressure to a tube, as known in the art. The supplied air travels through the tube and into the tube portion 36 of the mask 10. From there it travels into the mask shell's central cavity 22, through the face cushion's front and rear openings 78, 80 and into the user's nasal passageways, to be inhaled by the user.

[0056] The nasal mask 10 described herein may incorporate one or more exhaust ports 106 to permit gas exhaled by the user (e.g. carbon dioxide) to exit the mask 10 before the user's next inhalation. The exhaust port(s) 106 may be located somewhere in the face cushion 14, in the central body 16, in the gas inlet 18, or even in the tube somewhere proximate the nasal mask 10. In the drawings the exhaust ports 106 are shown in the central body 16. One of ordinary skill in the art will know of several exhaust port designs which permit exhaust of gas exhaled by the user, and also do not permit exhaust of gas supplied through the tube.

[0057] The presently disclosed mask 10 is a nasal mask only. This device may easily be modified to become a combined nasal / mouth mask by making the central cavity 16 and face cushion 14 large enough to encompass the user's nose and mouth. Or, use of two separate nasal and mouth bodies connected by an airway conduit may be preferable to maintain a better seal

with the user's face or for some other reason. Other methods of making a combined nasal / mouth mask may be known to one of ordinary skill in the art. Similarly the presently disclosed device may be made as a mouth mask only.

[0058] While the present invention has been illustrated by the description of embodiments thereof, and while the embodiments have been described in considerable detail, it is not the intention of the applicant to restrict or in any way limit the scope of the appended claims to such detail. Additional advantages and modifications will readily appear to those skilled in the art. Therefore, the invention in its broader aspects is not limited to the specific details, representative apparatus and method, and illustrative examples shown and described. Accordingly, departures may be made from such details without departing from the spirit or scope of the applicant's general inventive concept.

The embodiments of the invention in which an exclusive property or privilege is claimed are defined as follows:

1. A nasal mask comprising:

a central body, the central body comprising an inlet aperture for receiving a delivered amount of gas;

a gas inlet rotatably disposed around the inlet aperture of the central body, the gas inlet comprising a central axis and a tube portion, wherein the tube portion receives the delivered amount of gas and has a tube axis, and wherein a tube angle is formed between the tube axis and the central axis of the gas inlet; and

the tube angle is between about 0 degrees and about 130 degrees; and

a face cushion attached to the central body.

2. The nasal mask of claim 1 wherein the tube angle is between about 0 degrees and about 90 degrees.

3. The nasal mask of claim 1 wherein the tube angle is between about 60 degrees and about 90 degrees.

4. The nasal mask of claim 1 wherein the tube angle is between about 75 degrees and about 90 degrees.

5. The nasal mask of claim 1 further comprising a forehead support connected to the central body and a forehead cushion removably mounted to the forehead support.

6. The nasal mask of claim 3 wherein the forehead support is pivotably connected to the central body

7. The nasal mask of claim 1 further comprising a rotation fitting having a first end and a second end, wherein the first end is rotatably disposed around the tube portion, and the second end receives a tube which supplies gas.

8. The nasal mask of claim 1 further comprising a gas inlet rotatably disposed around the inlet aperture of the central body and a rotation fitting having a first end and a second end, wherein the first end is rotatably disposed around the tube portion, and the second end receives a tube which supplies gas.

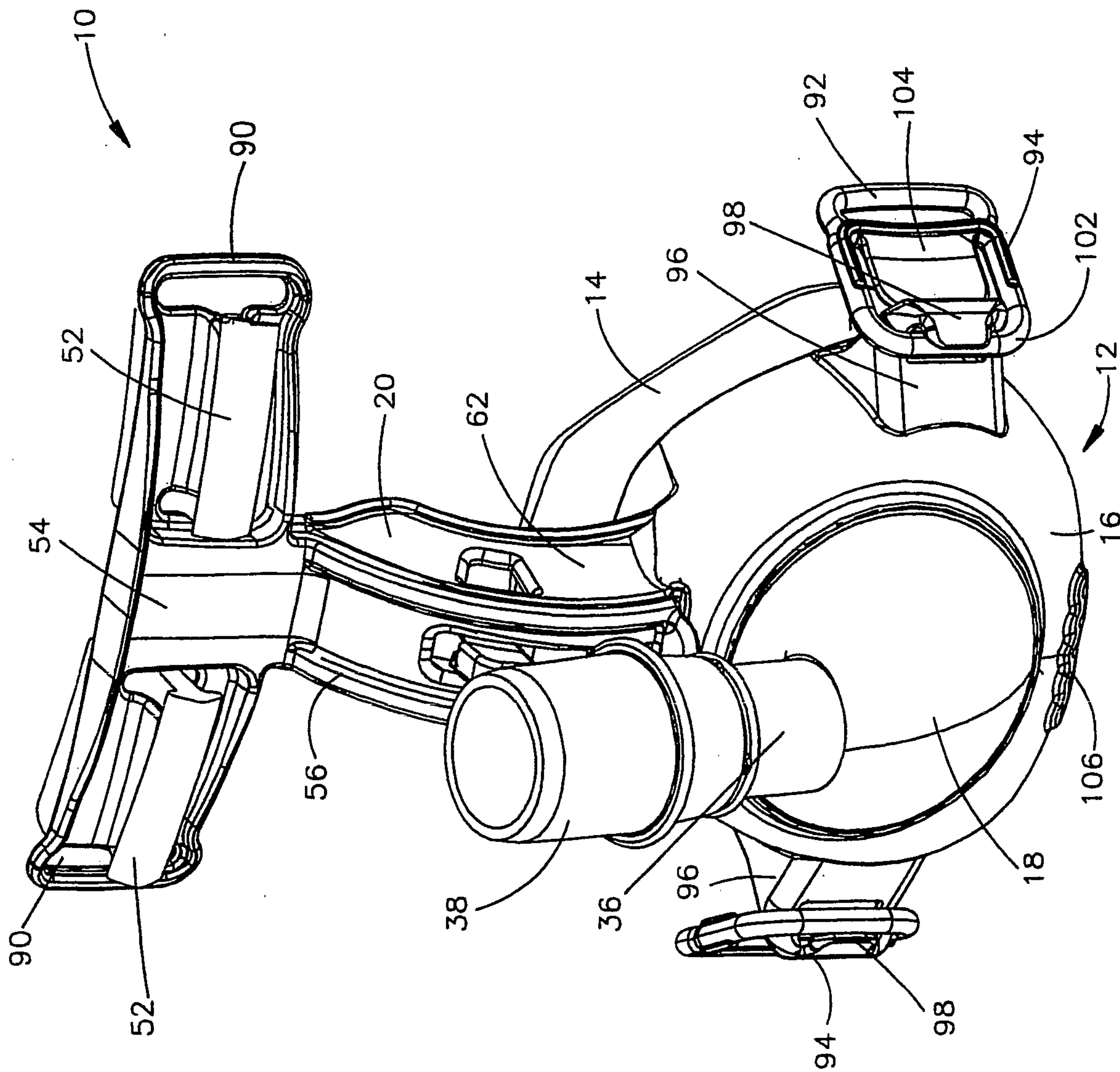

Fig.1

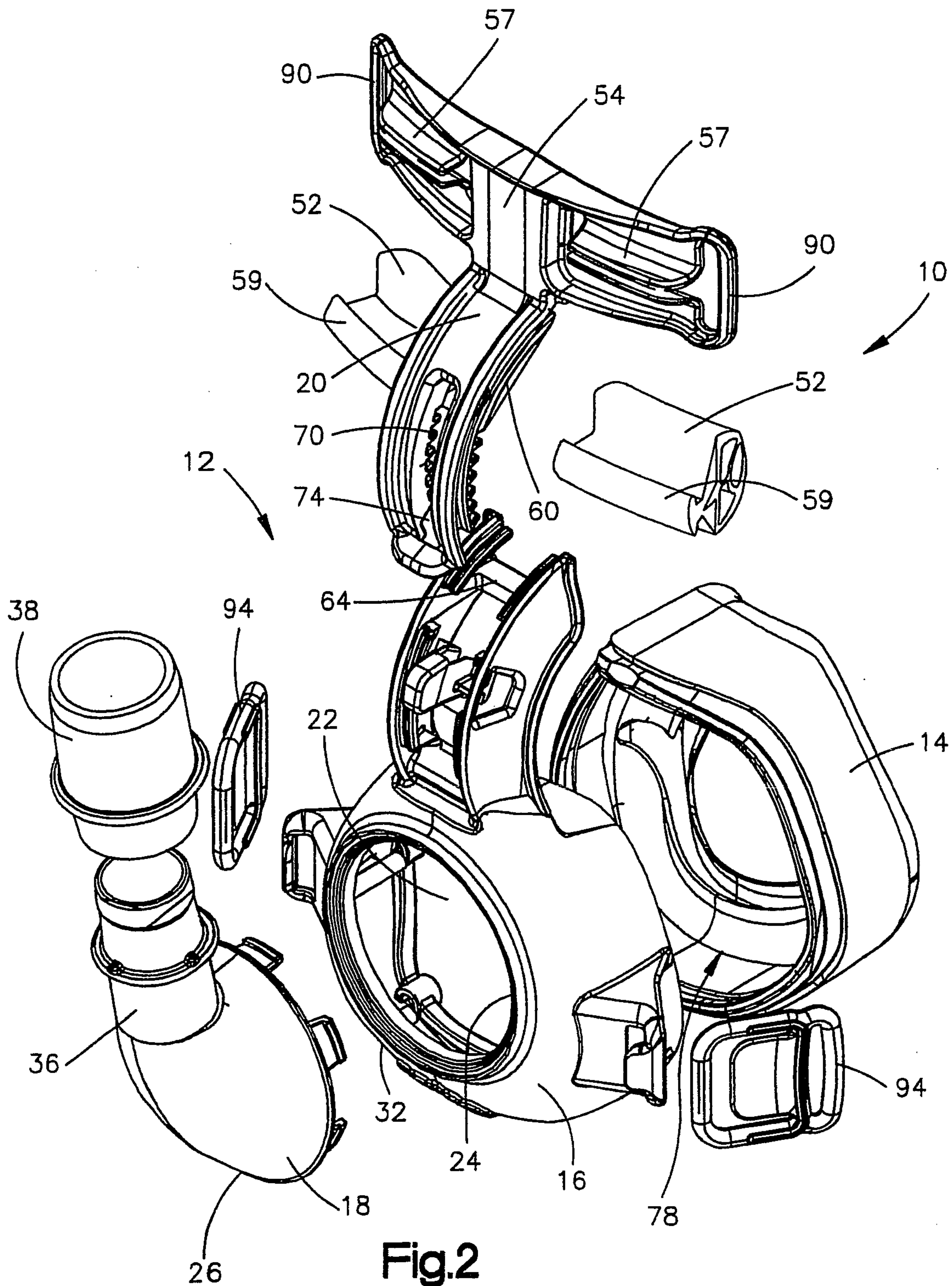

Fig.2



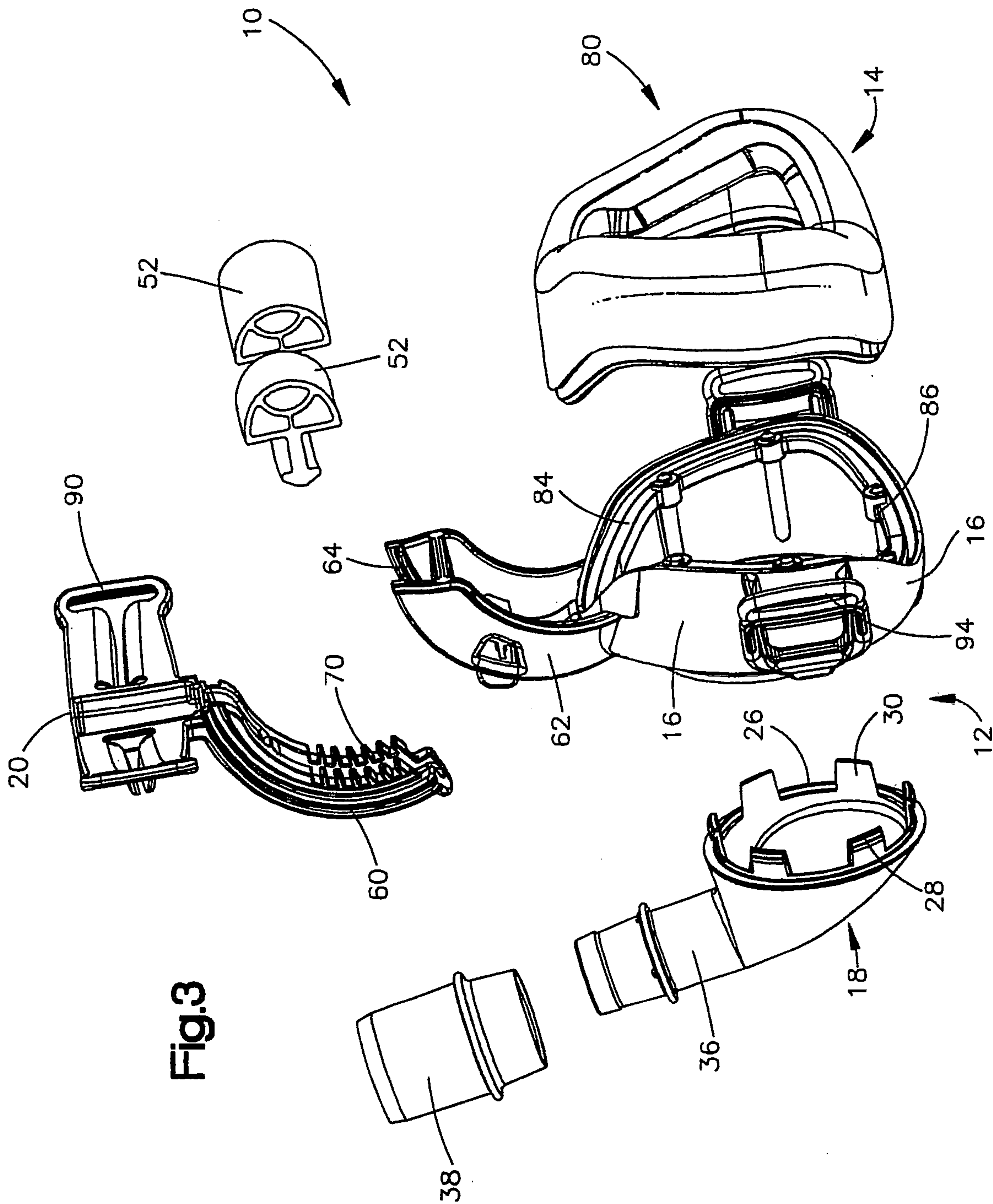
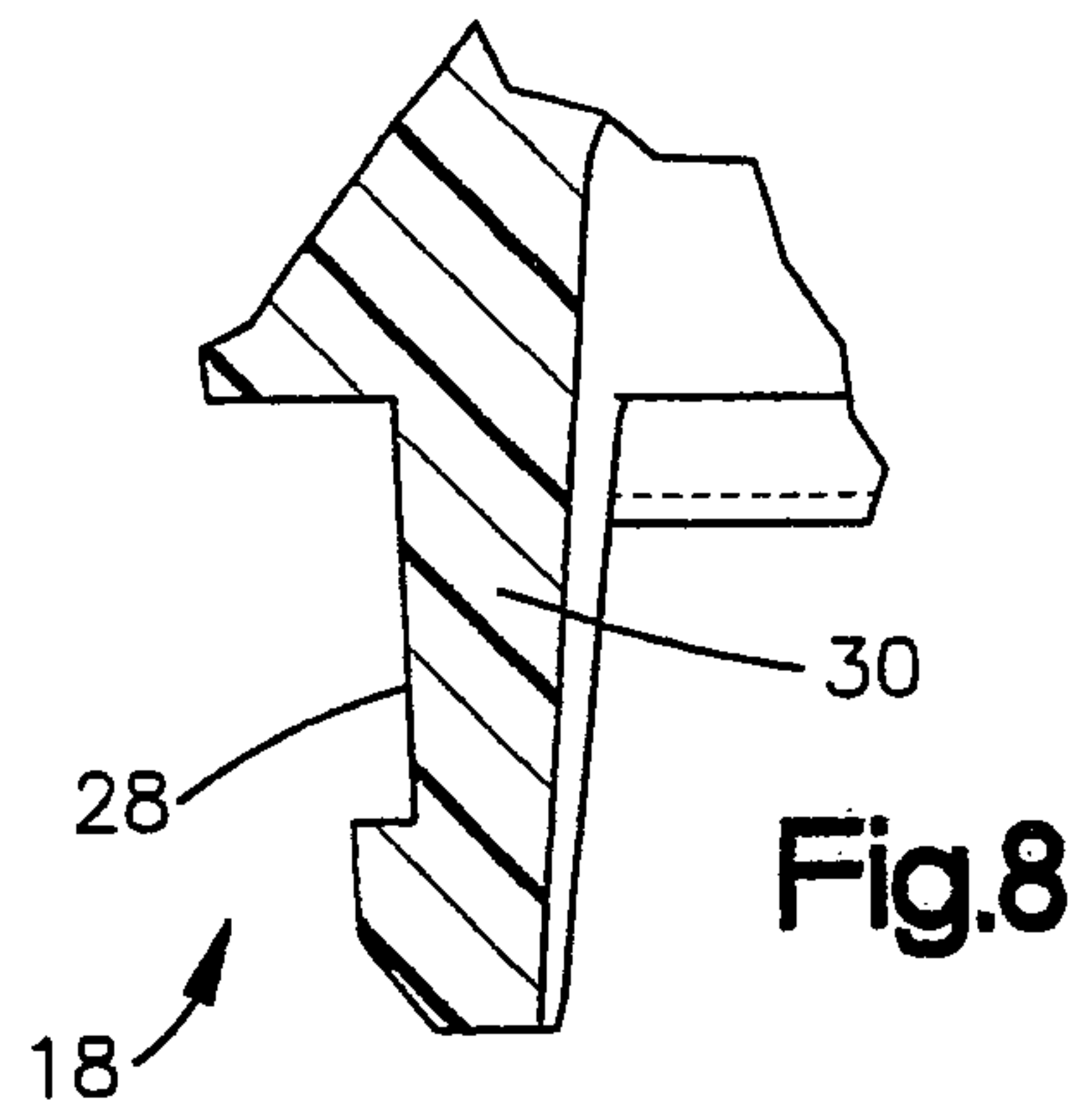
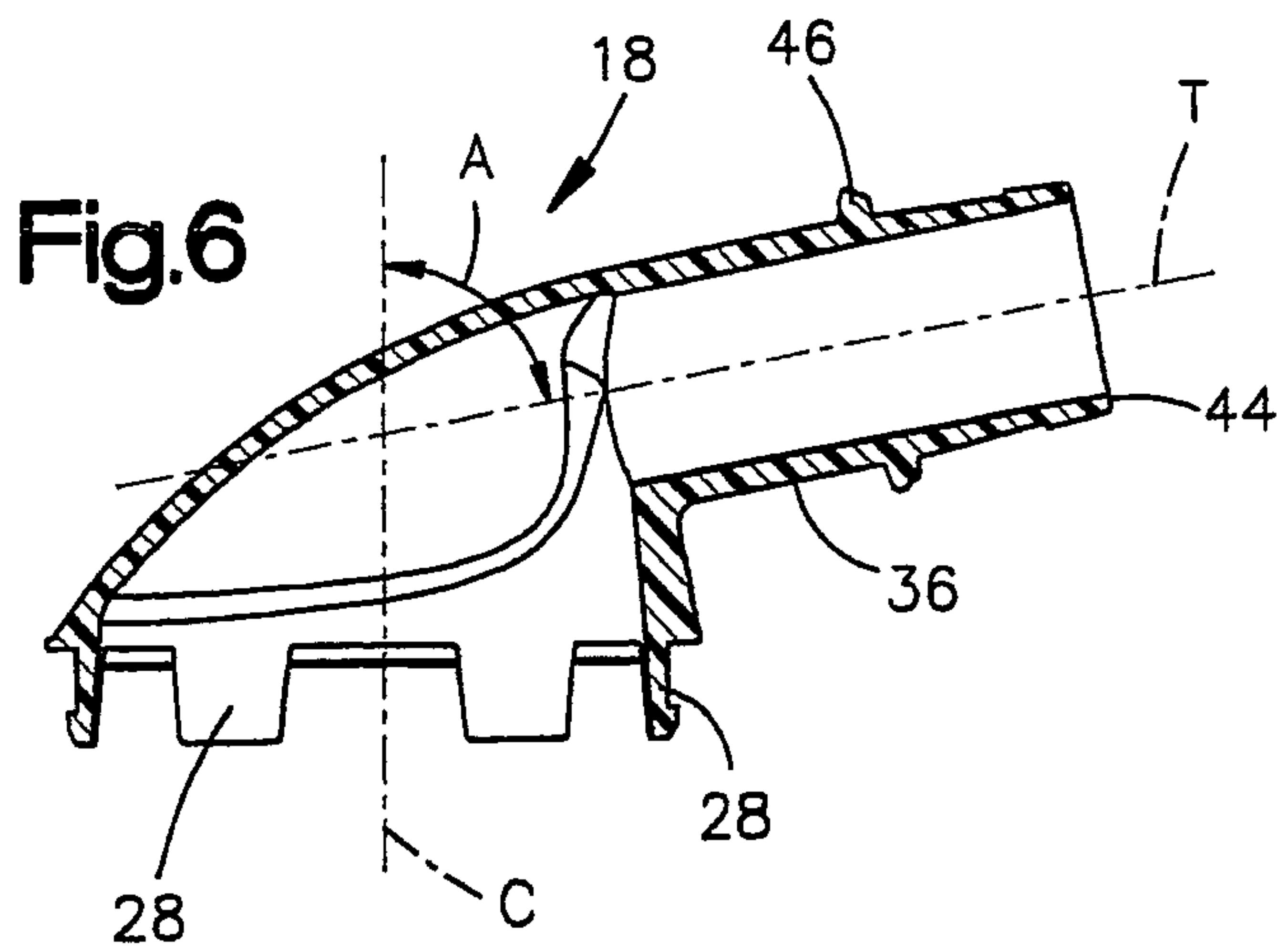
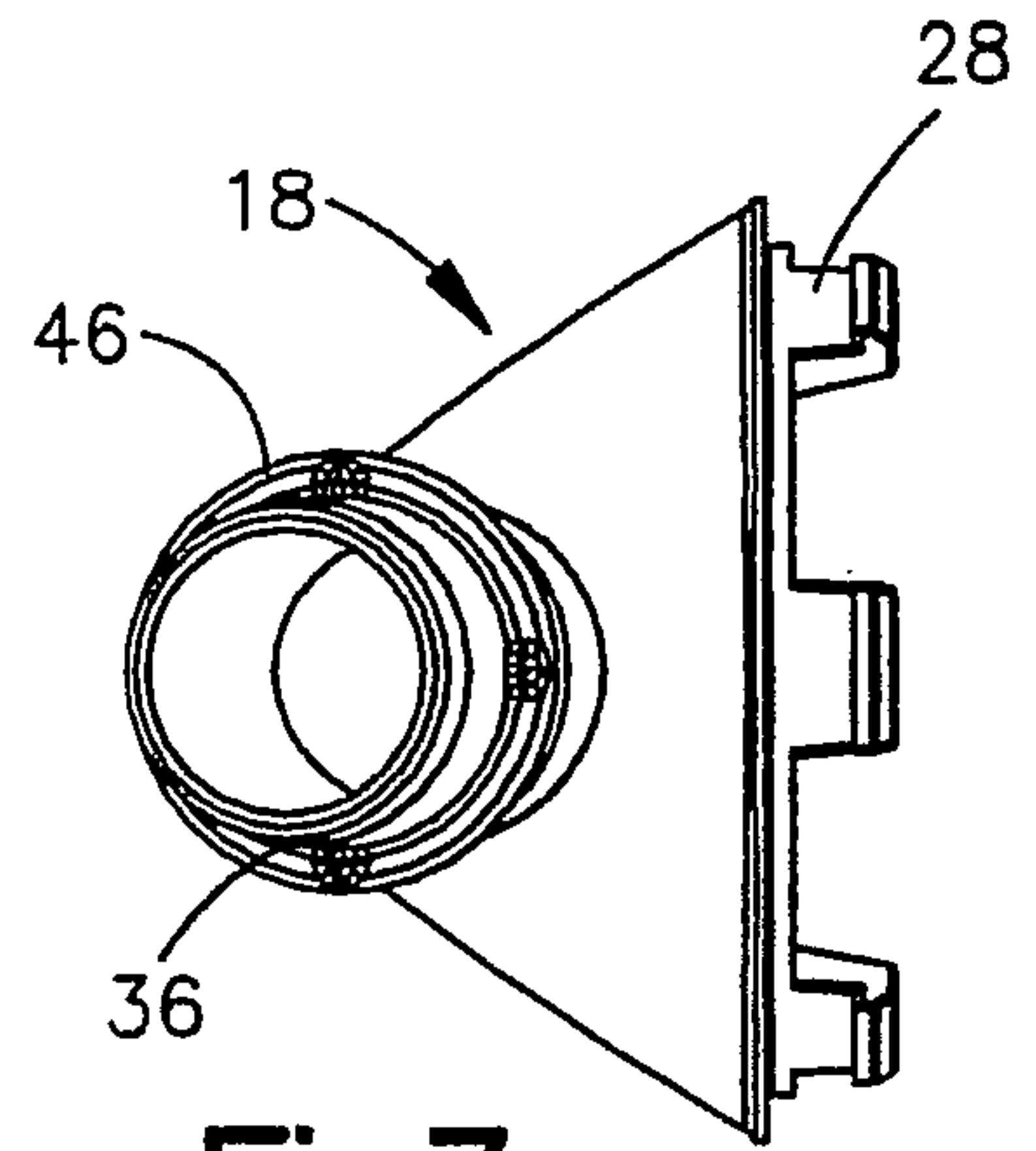
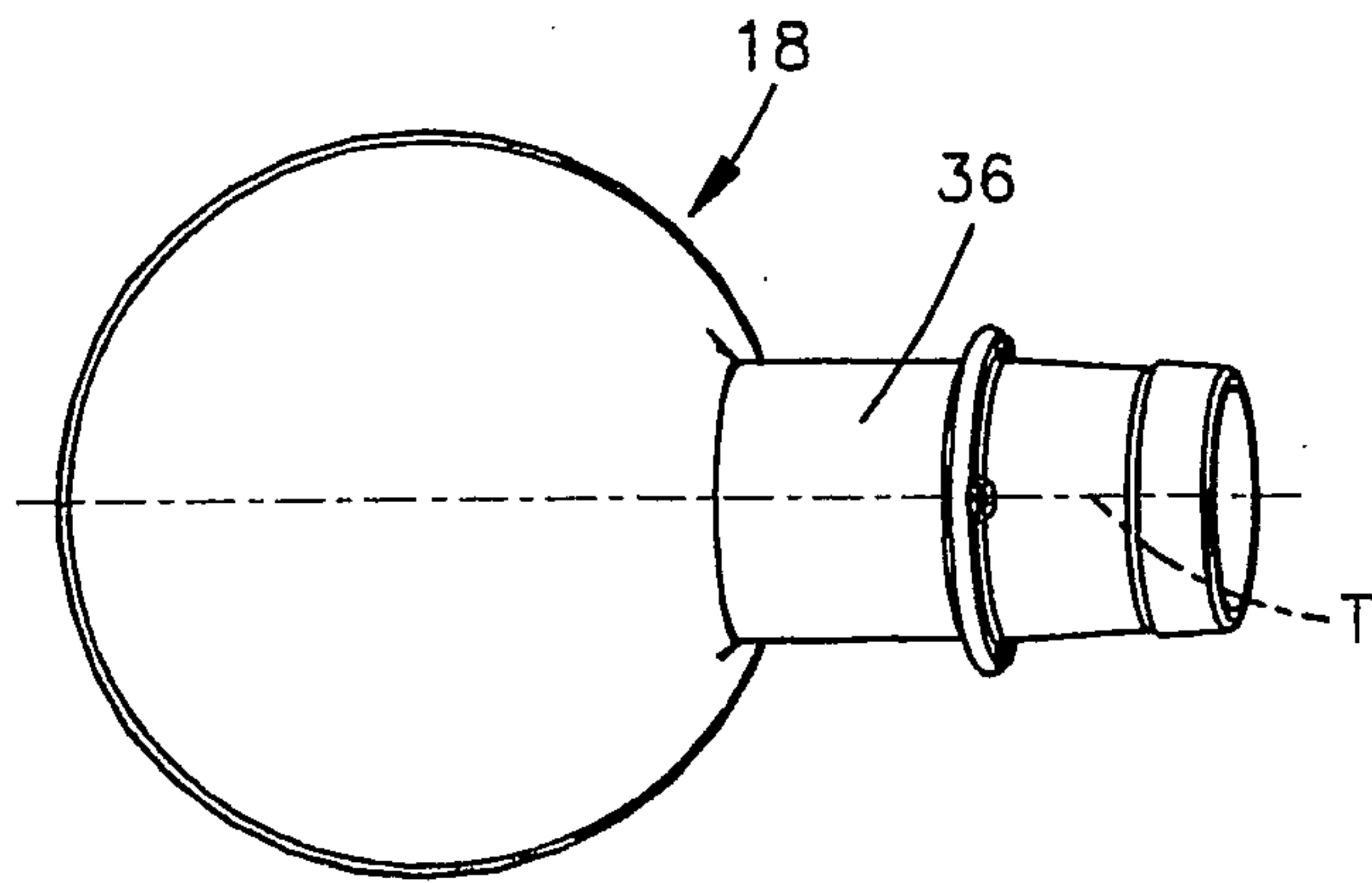
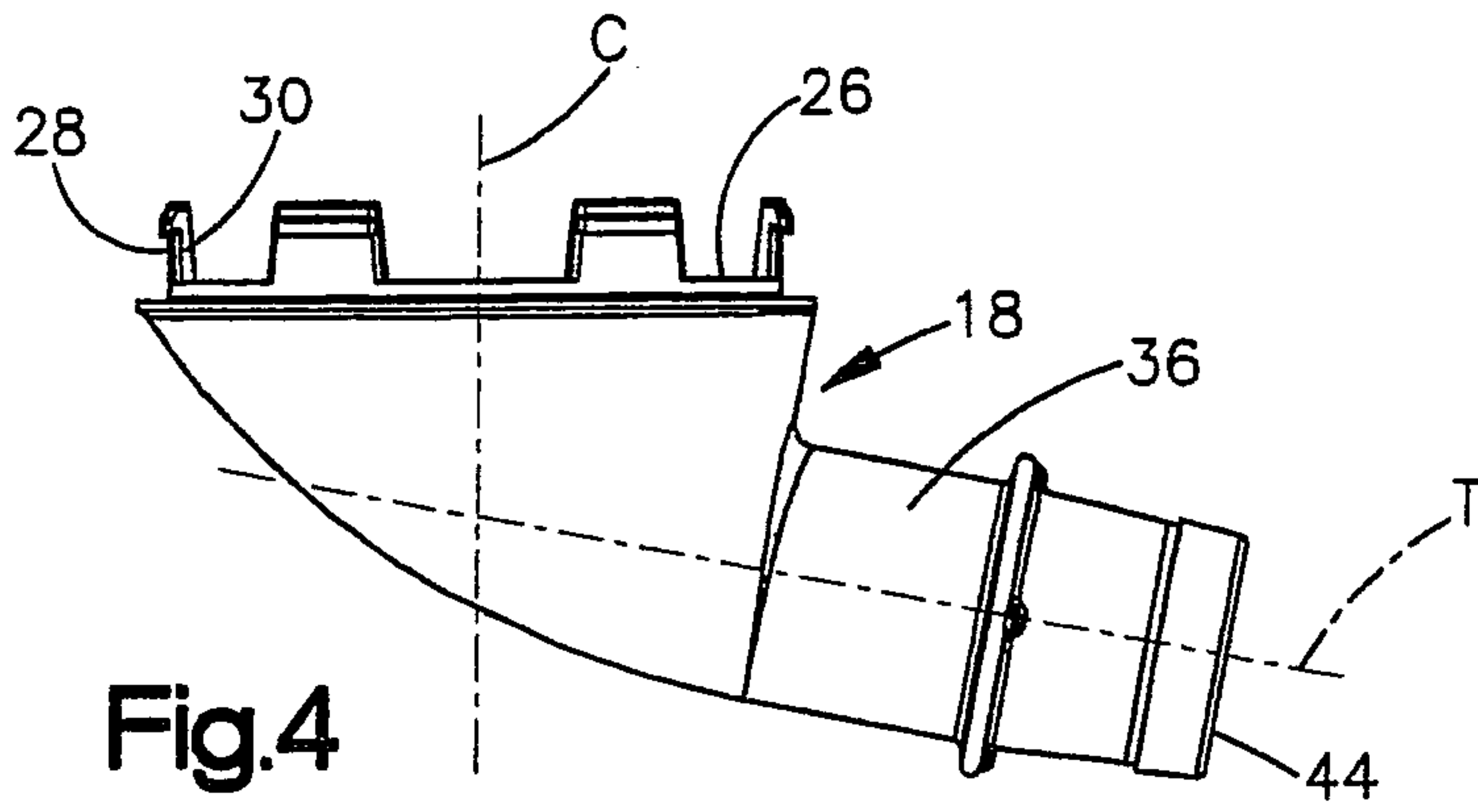

Fig.3



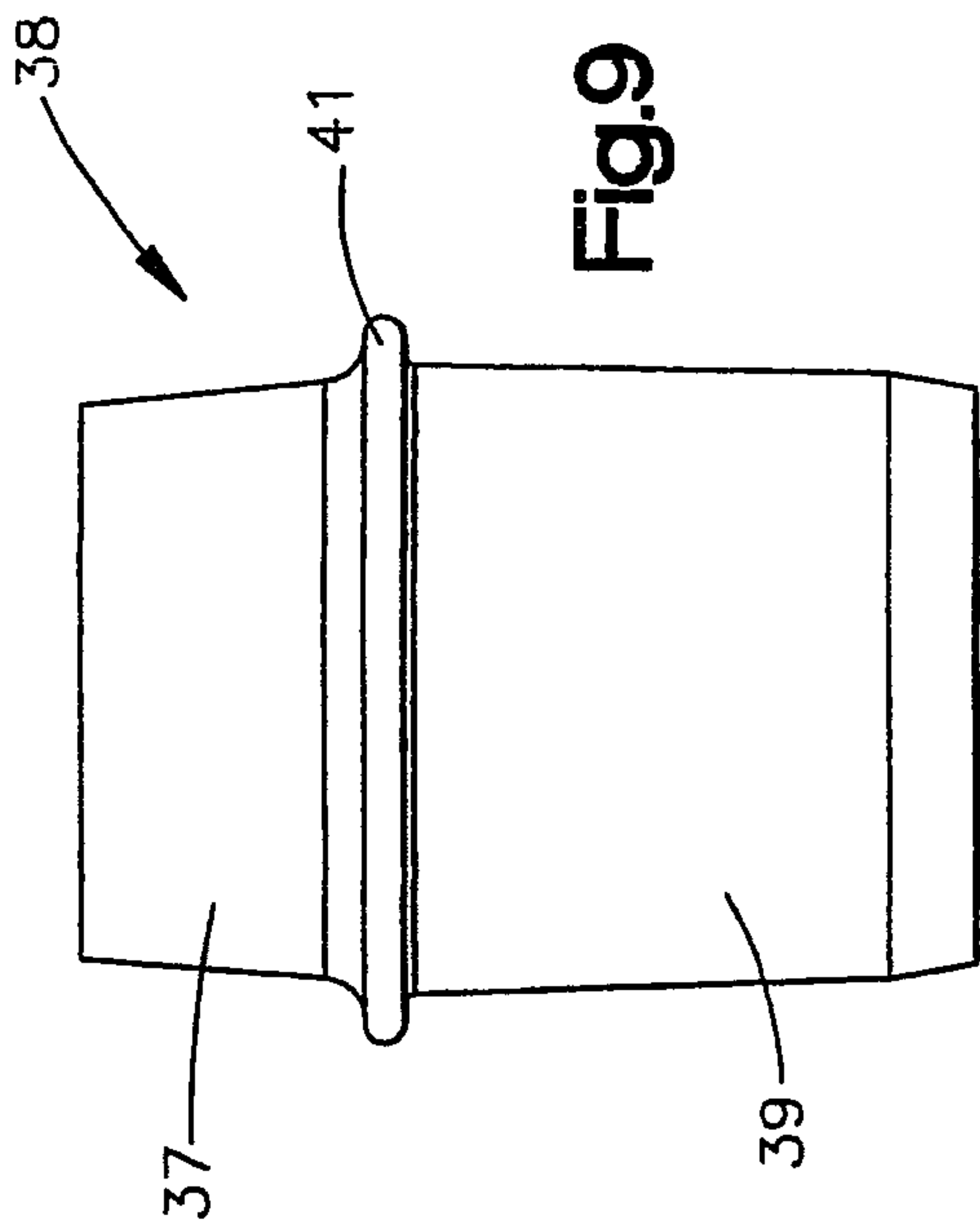

Fig. 9

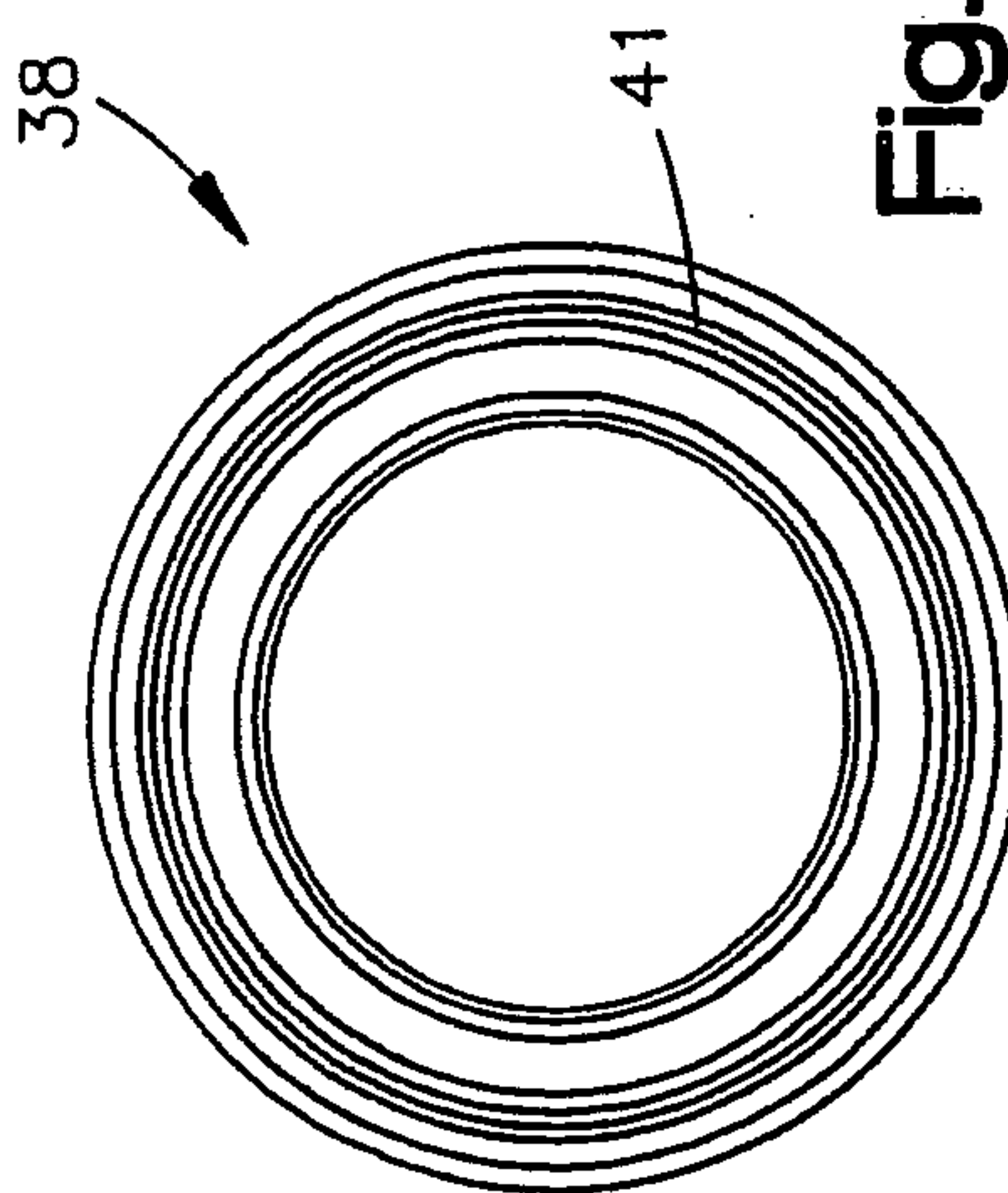

Fig. 10

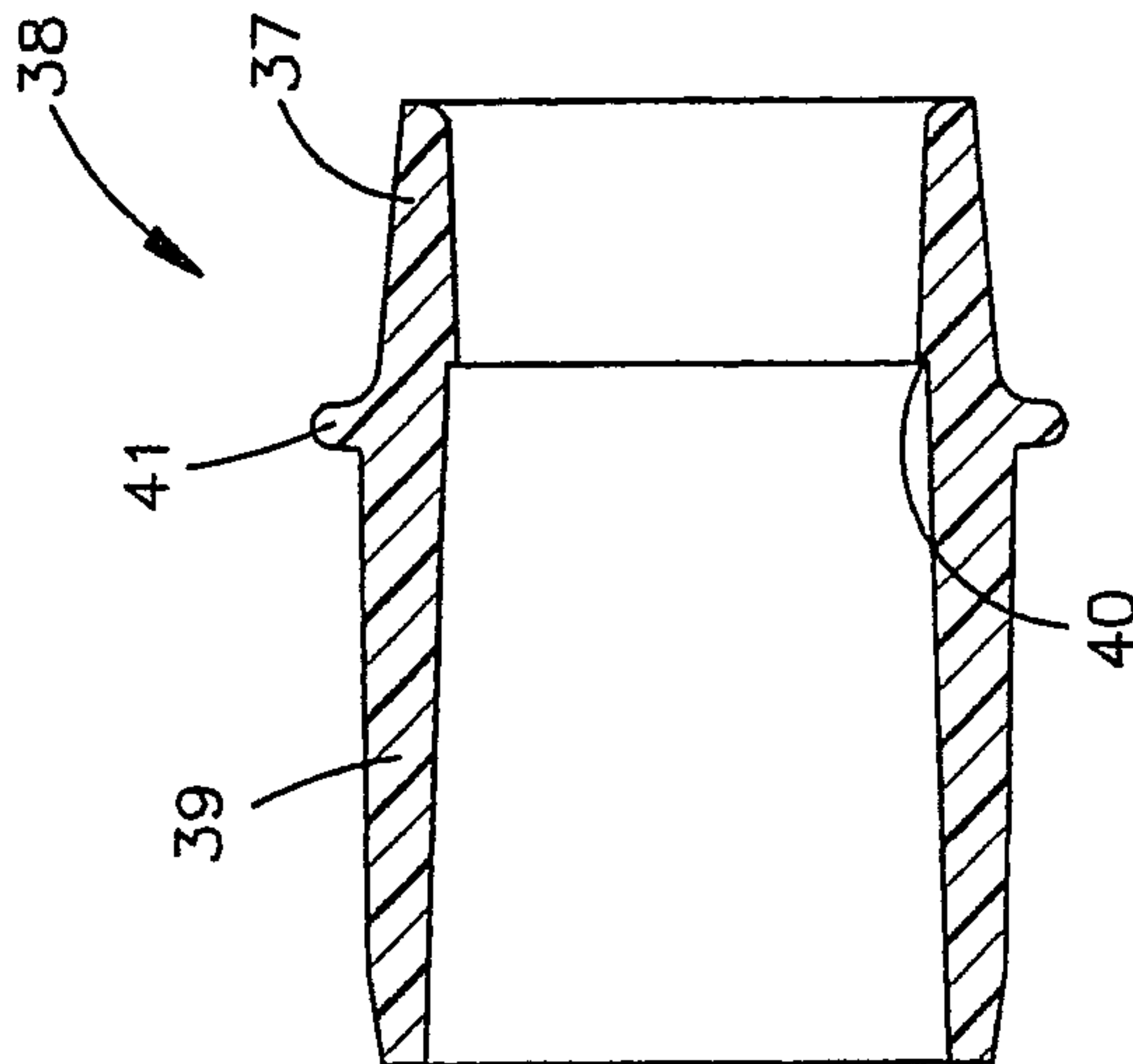
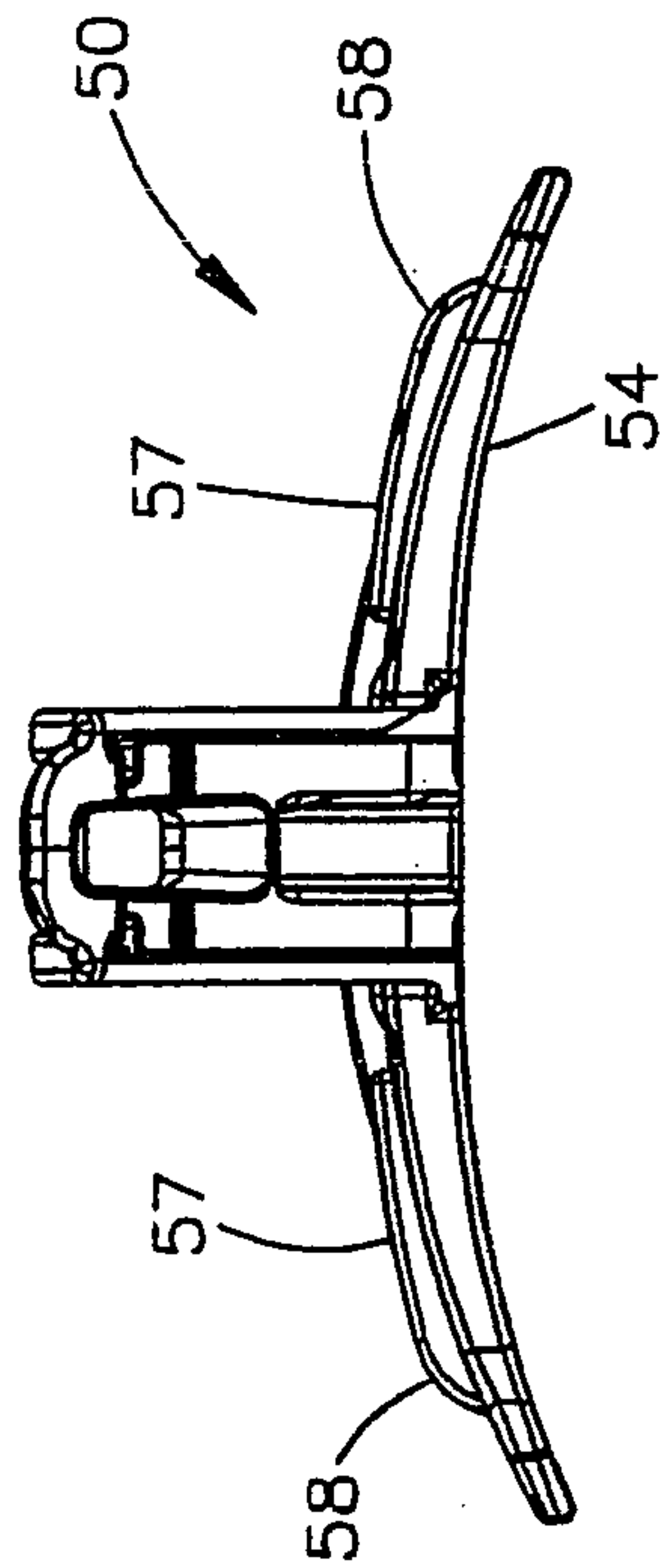
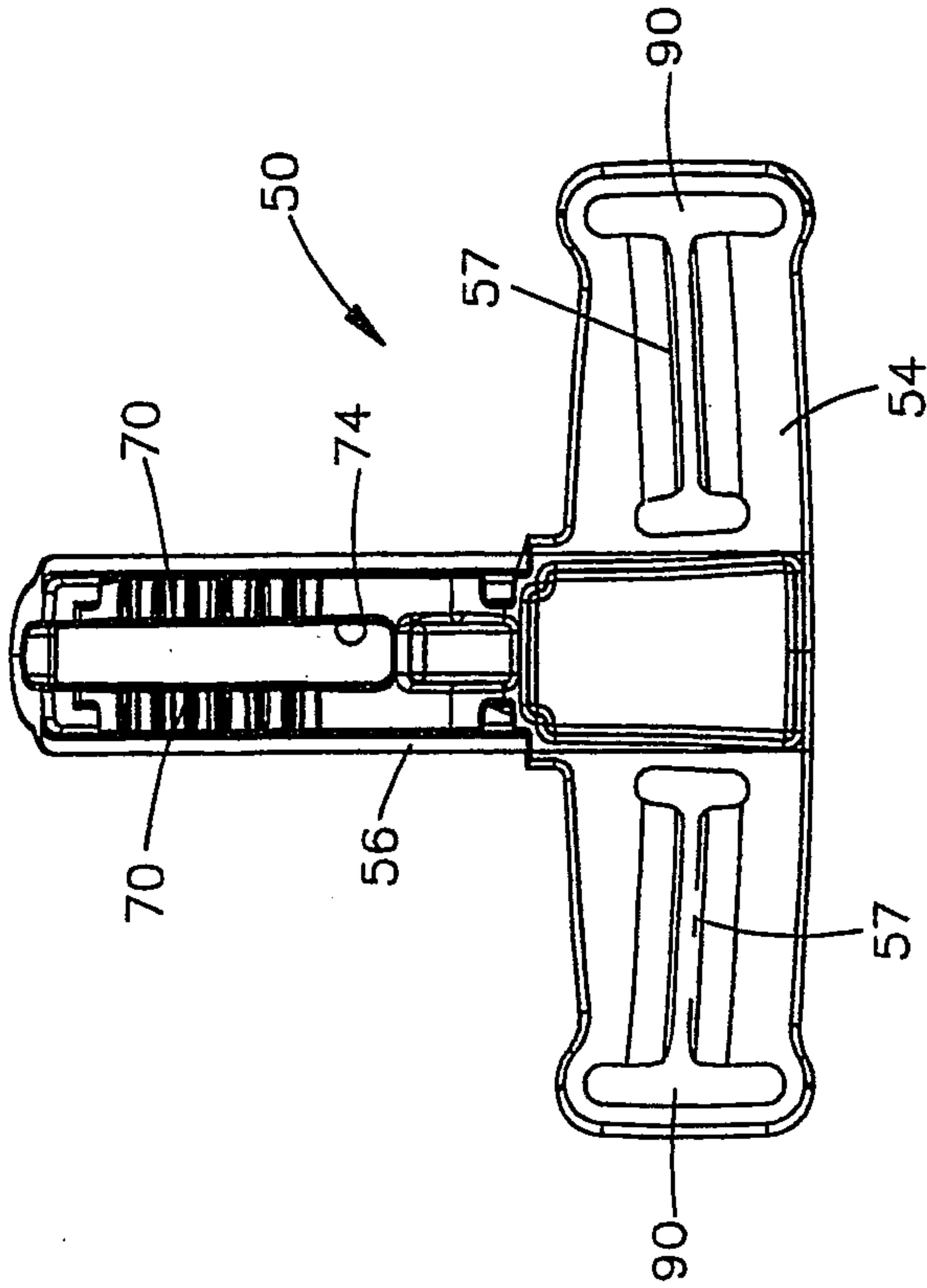
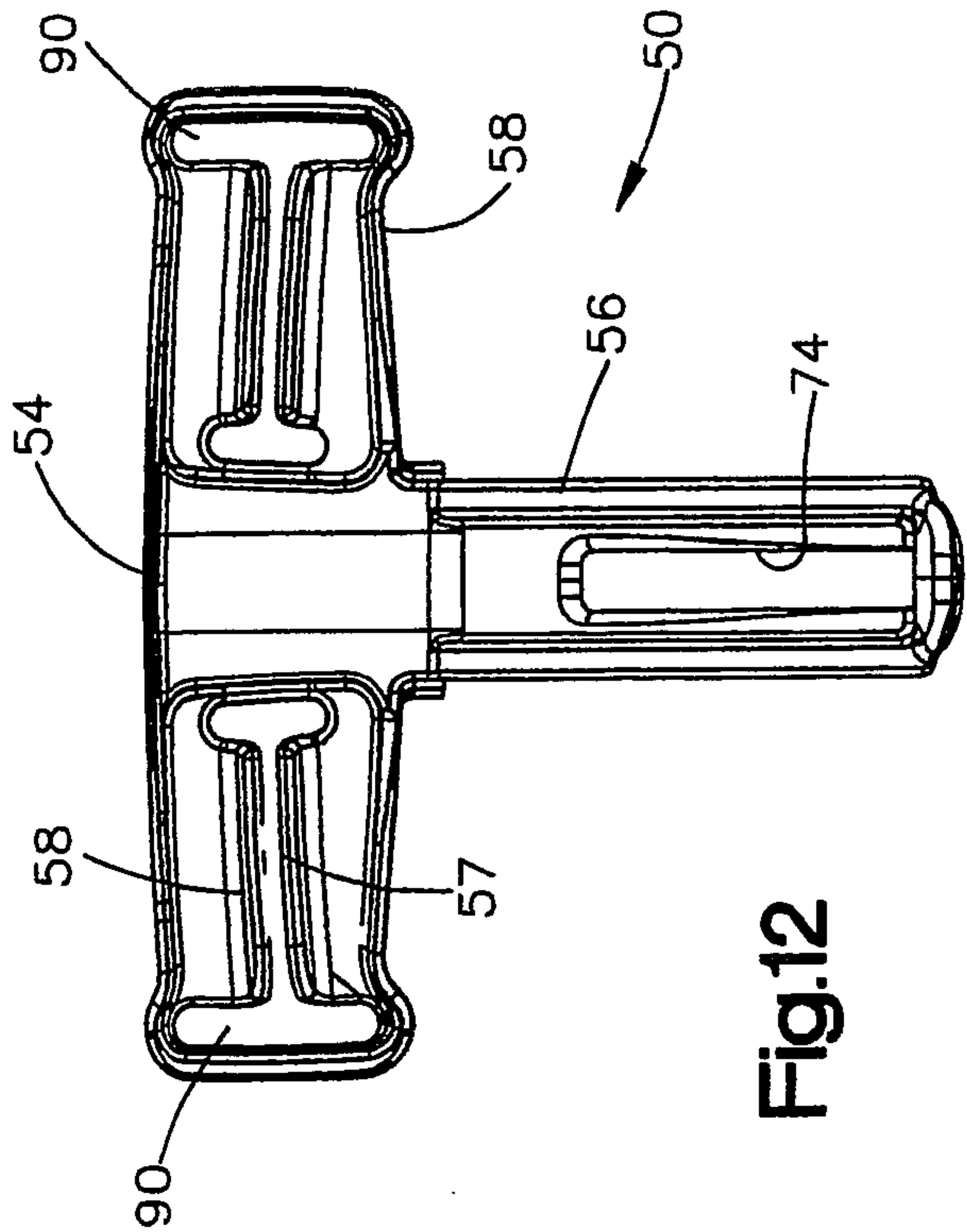

Fig. 11



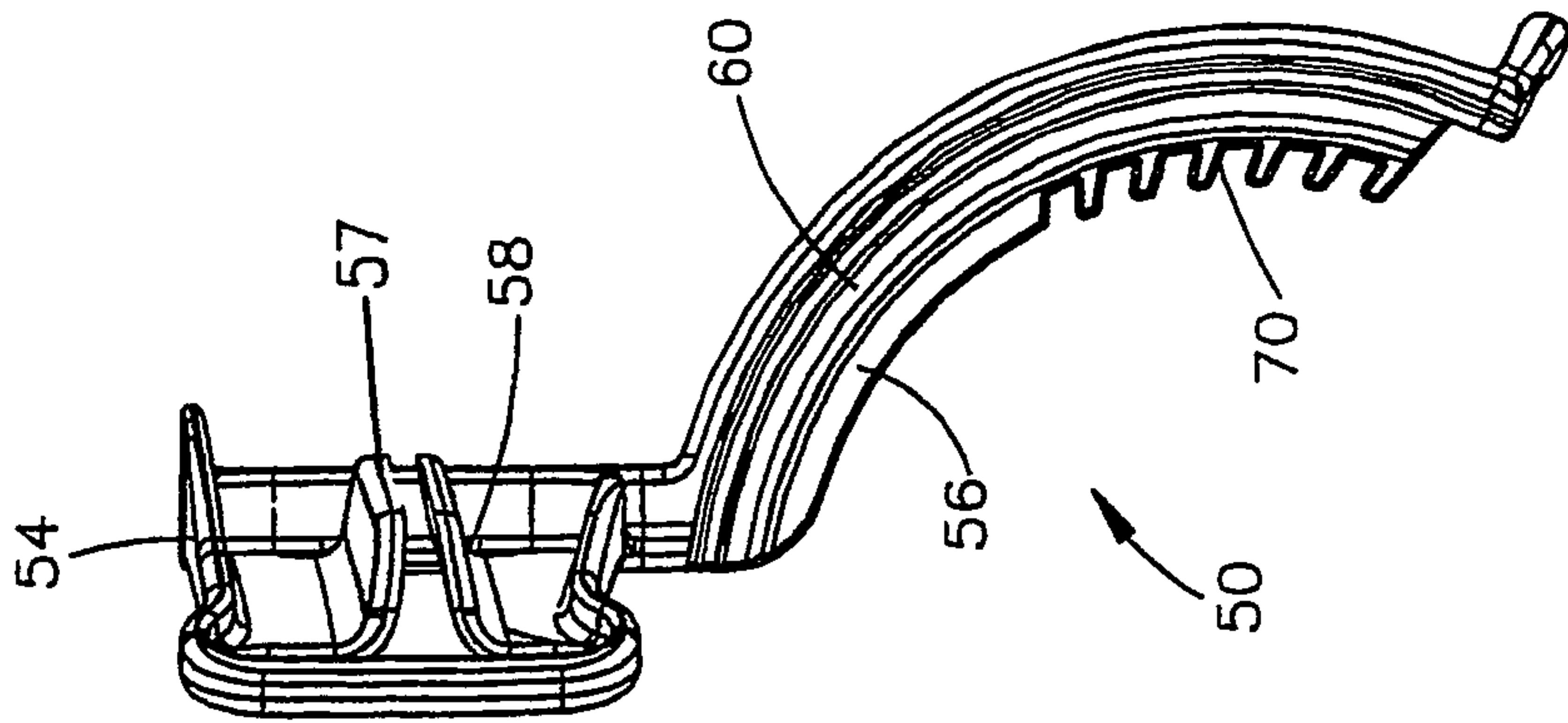

Fig.15

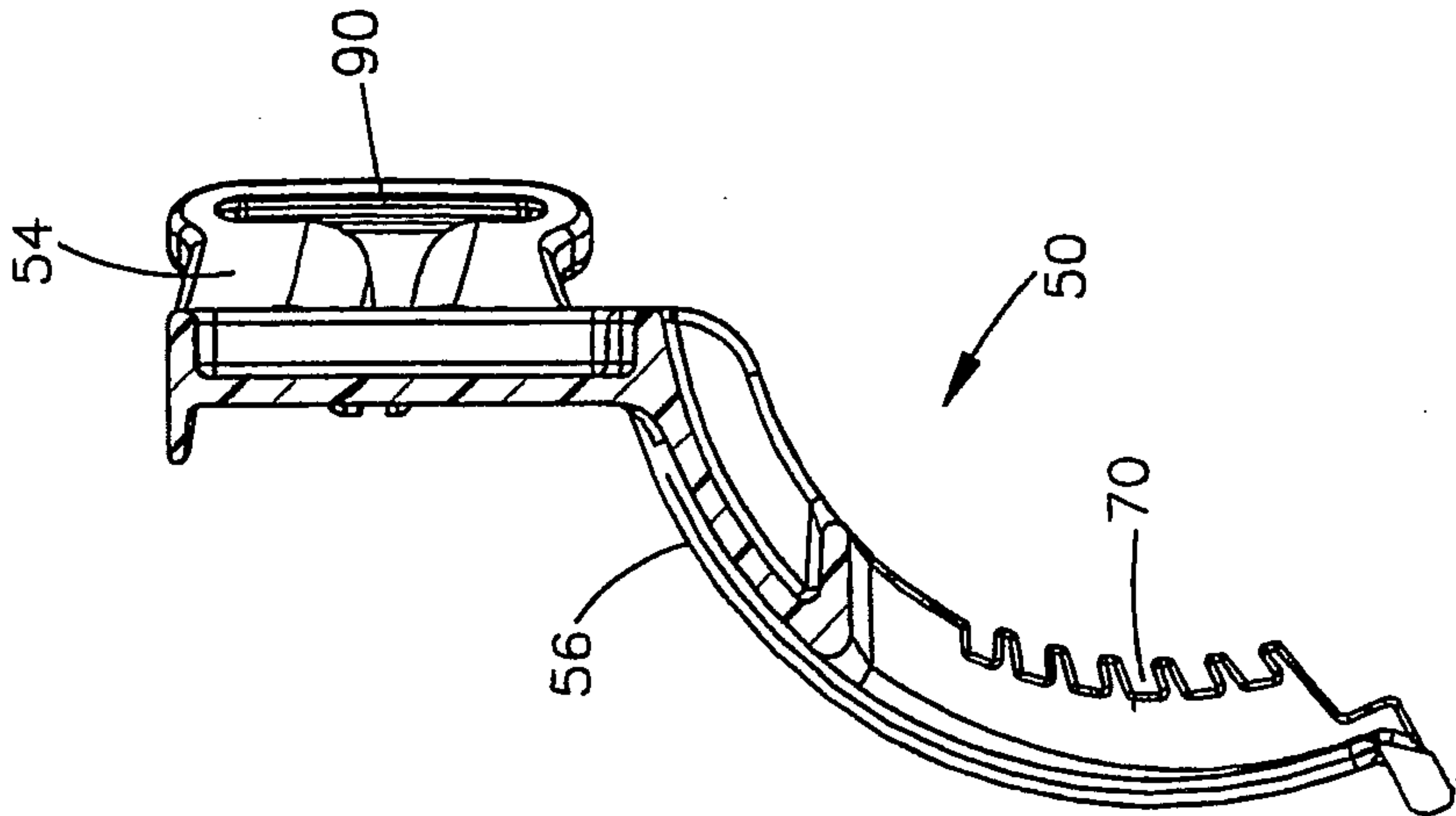

Fig.16

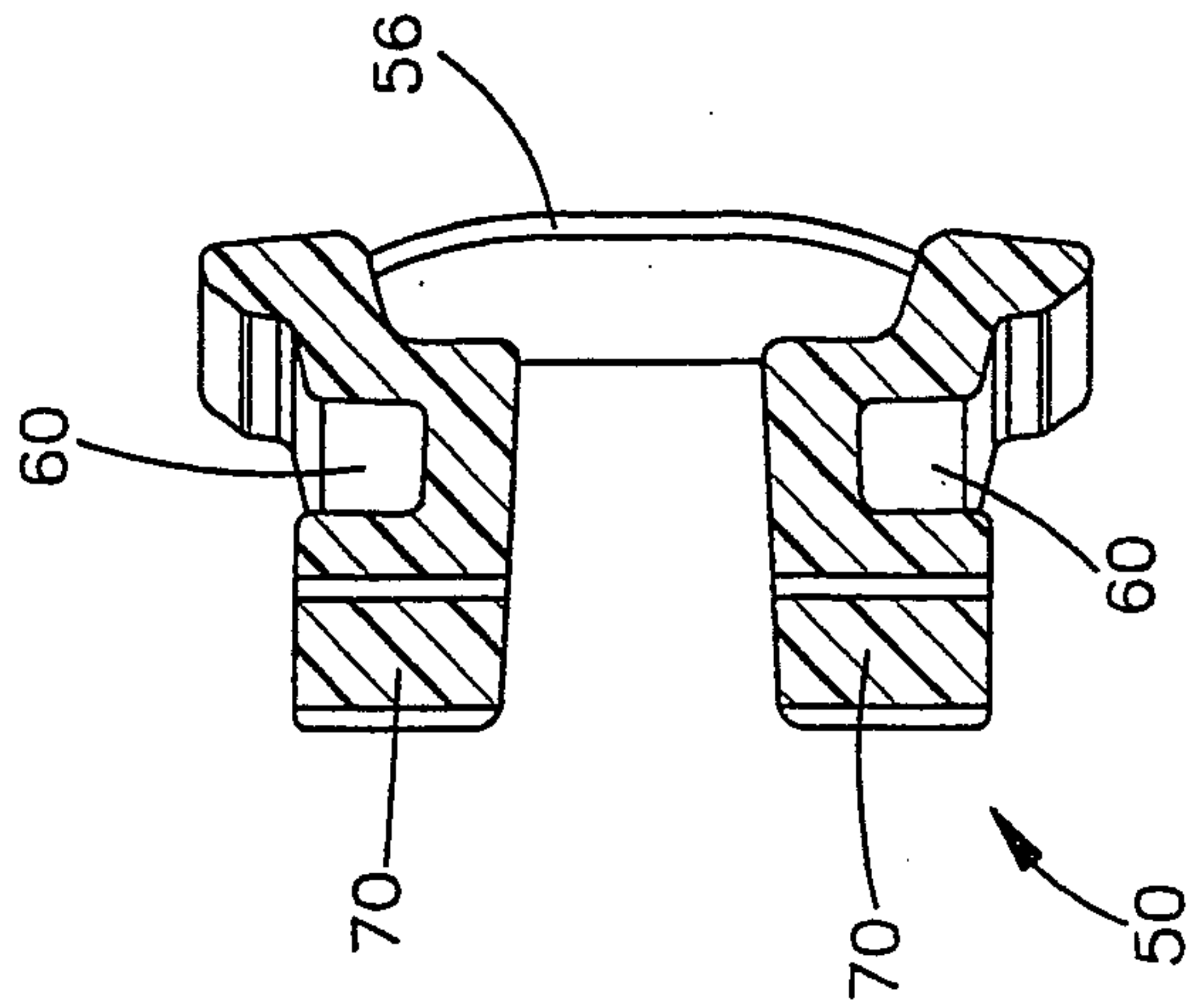
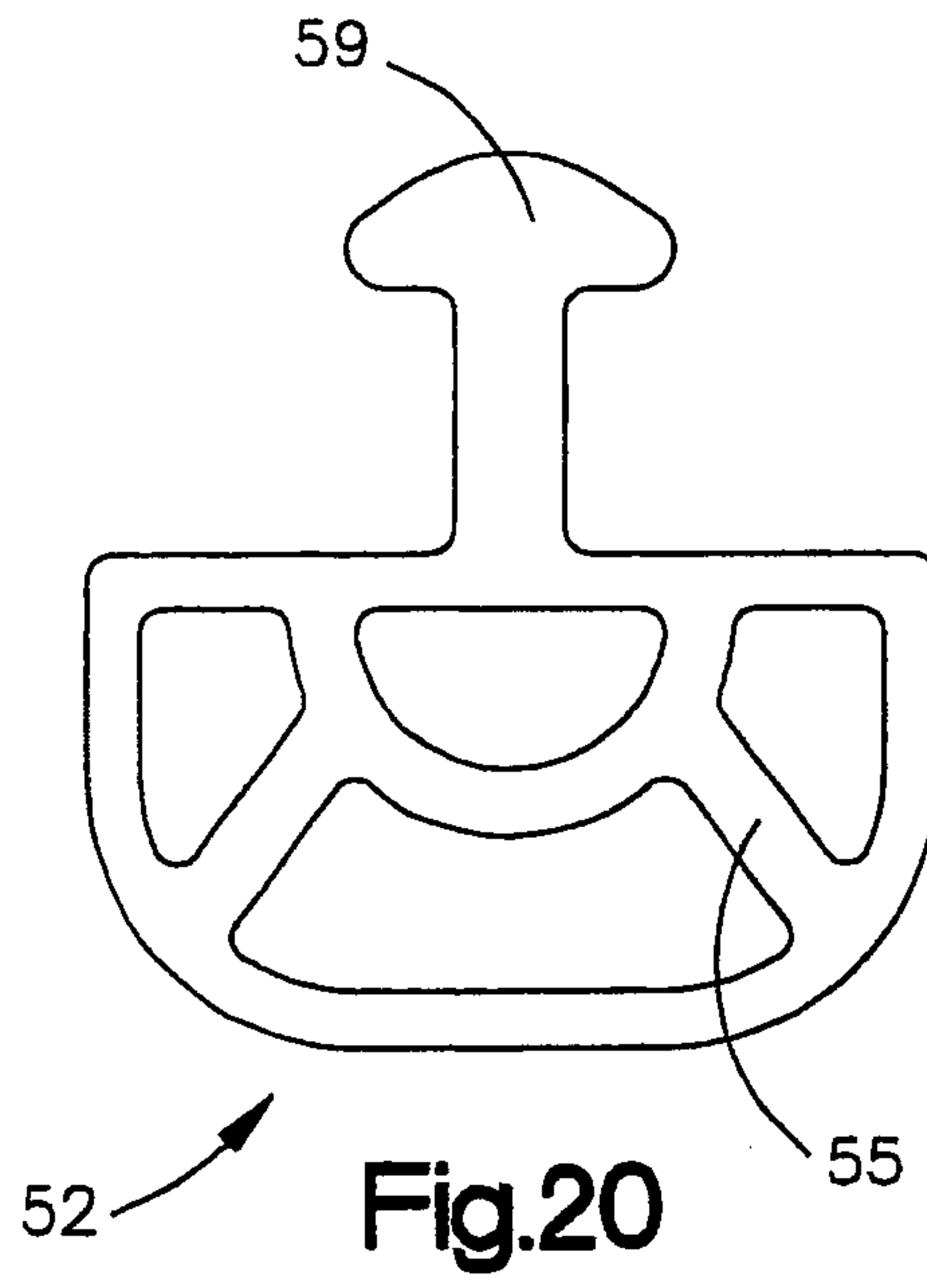
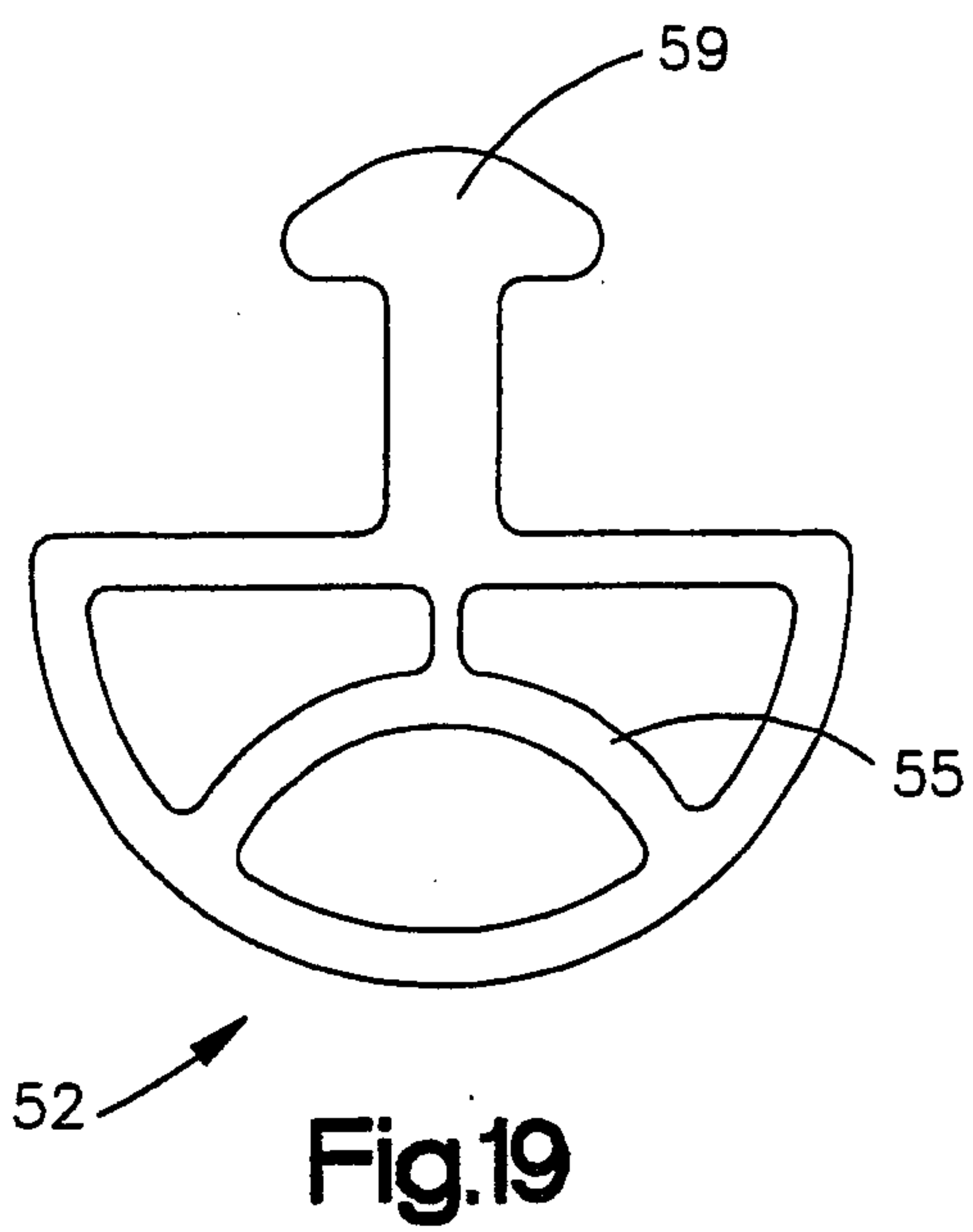
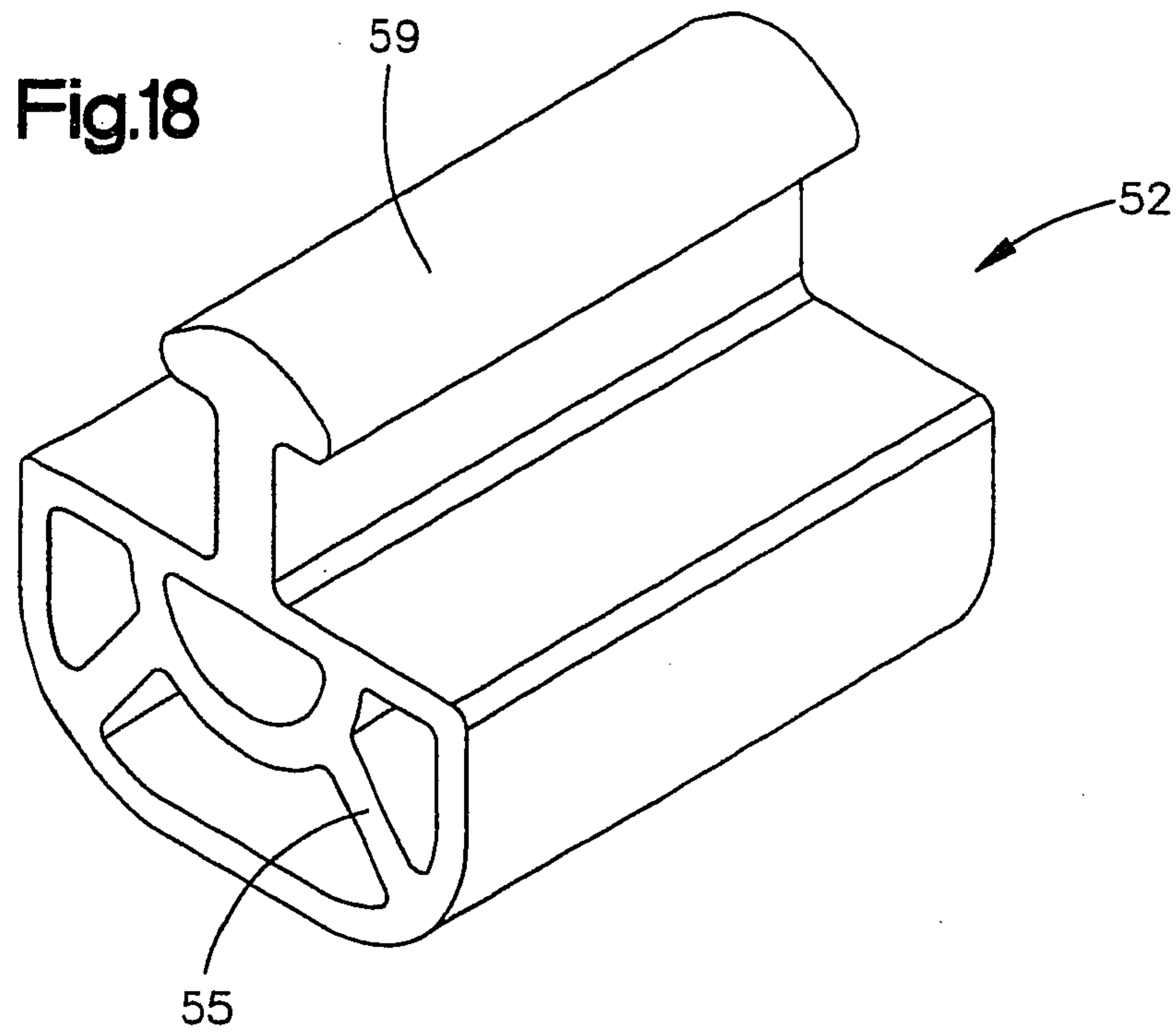

Fig.17



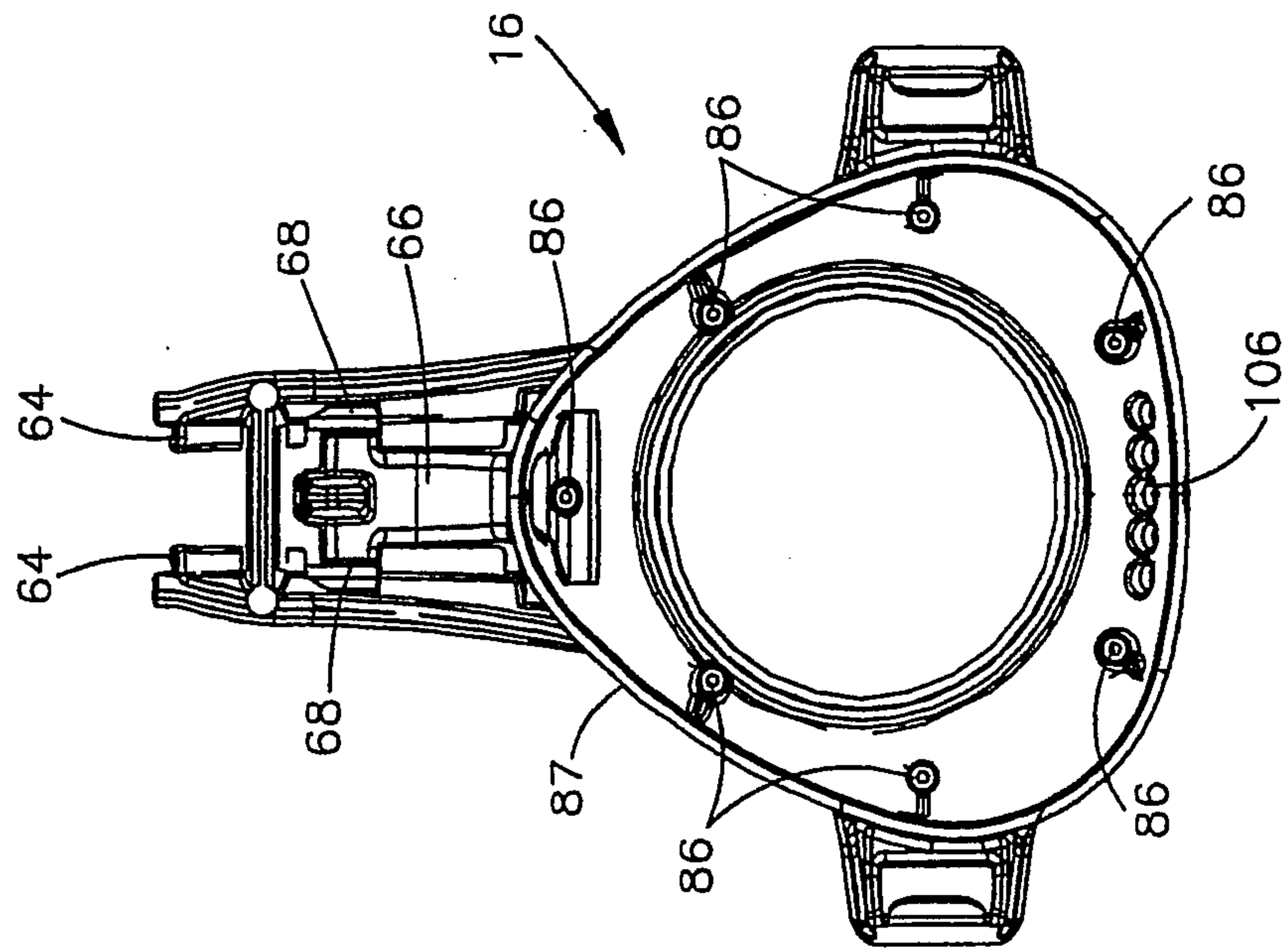

Fig.21

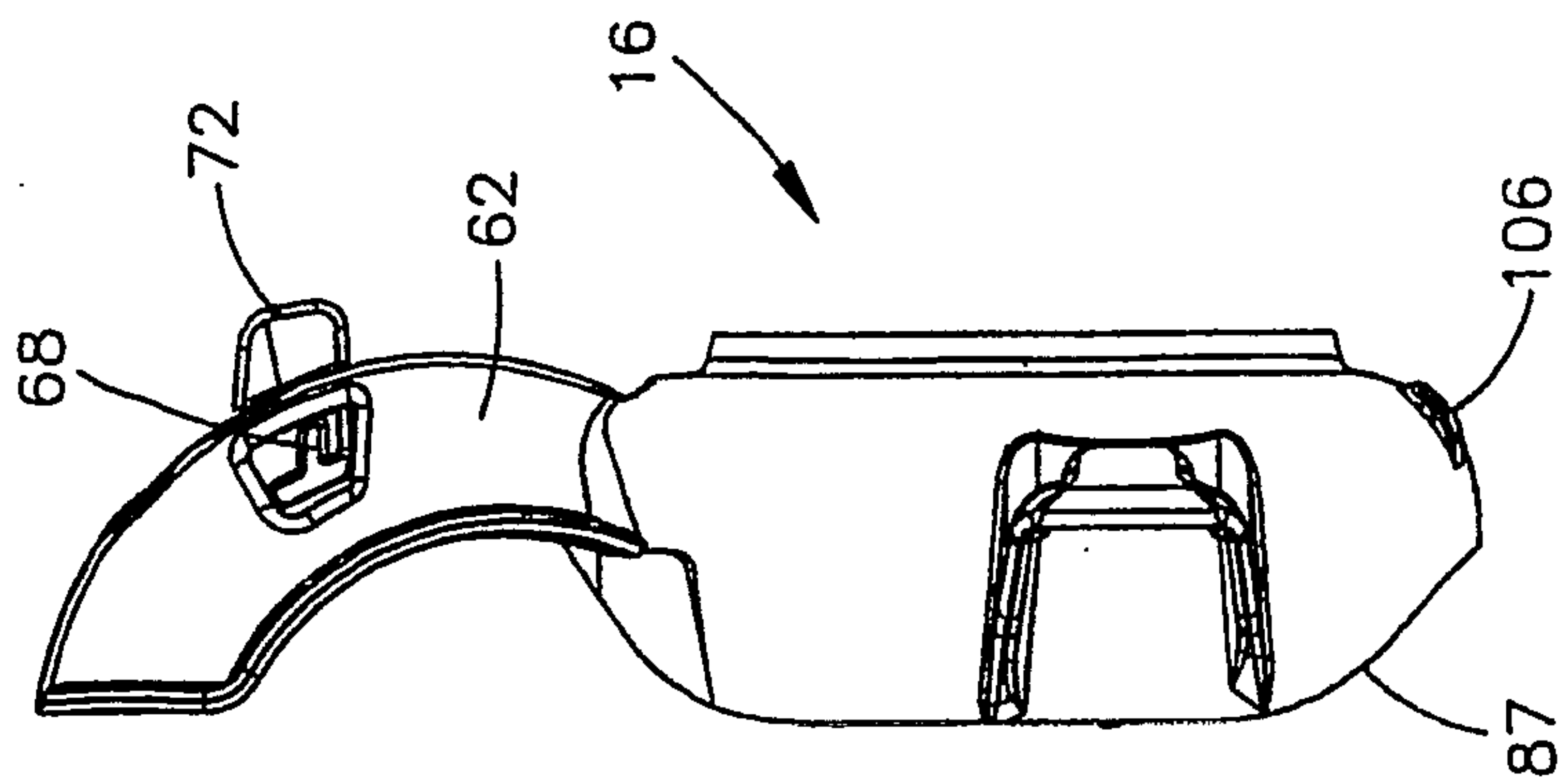

Fig.22

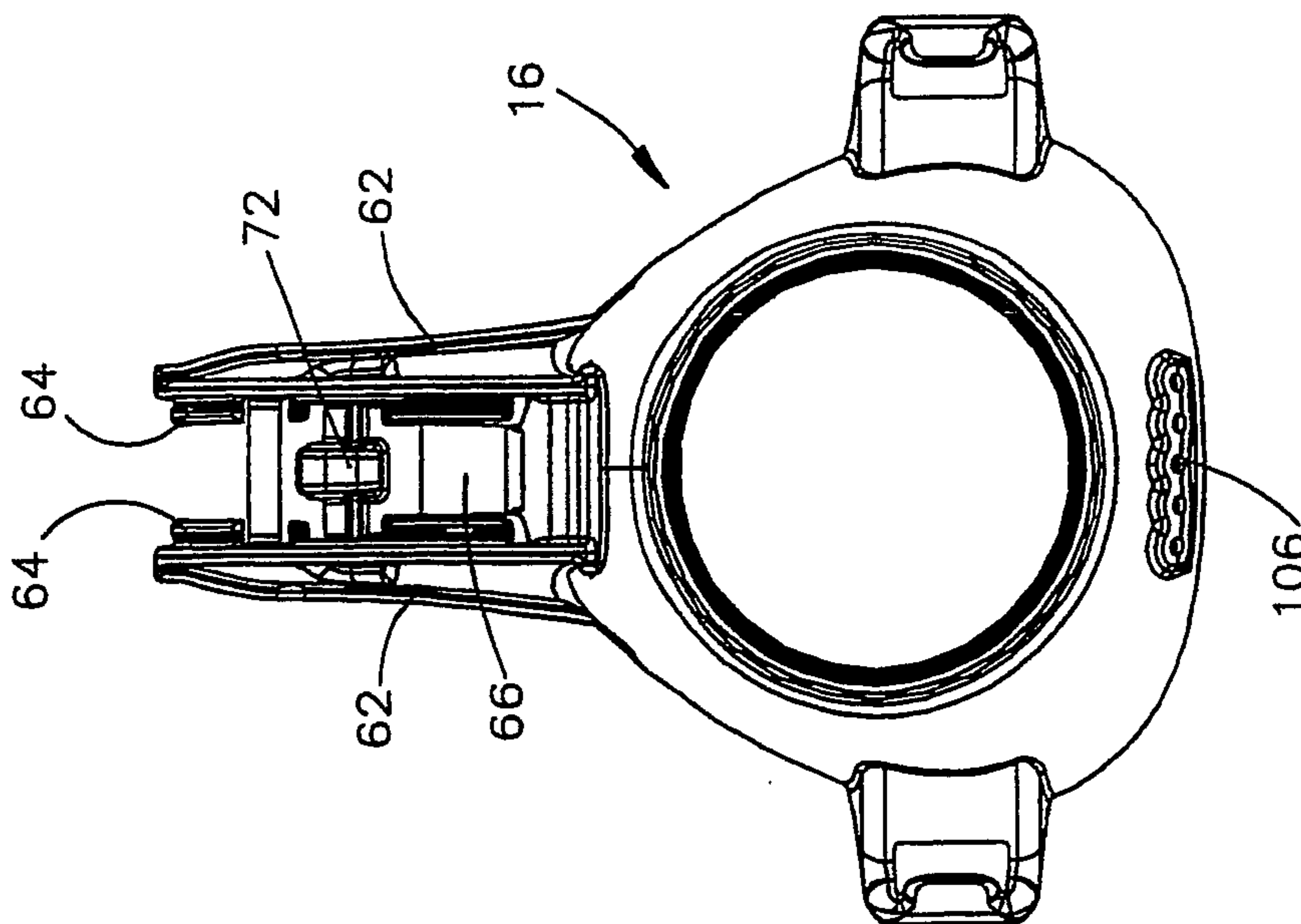

Fig.23

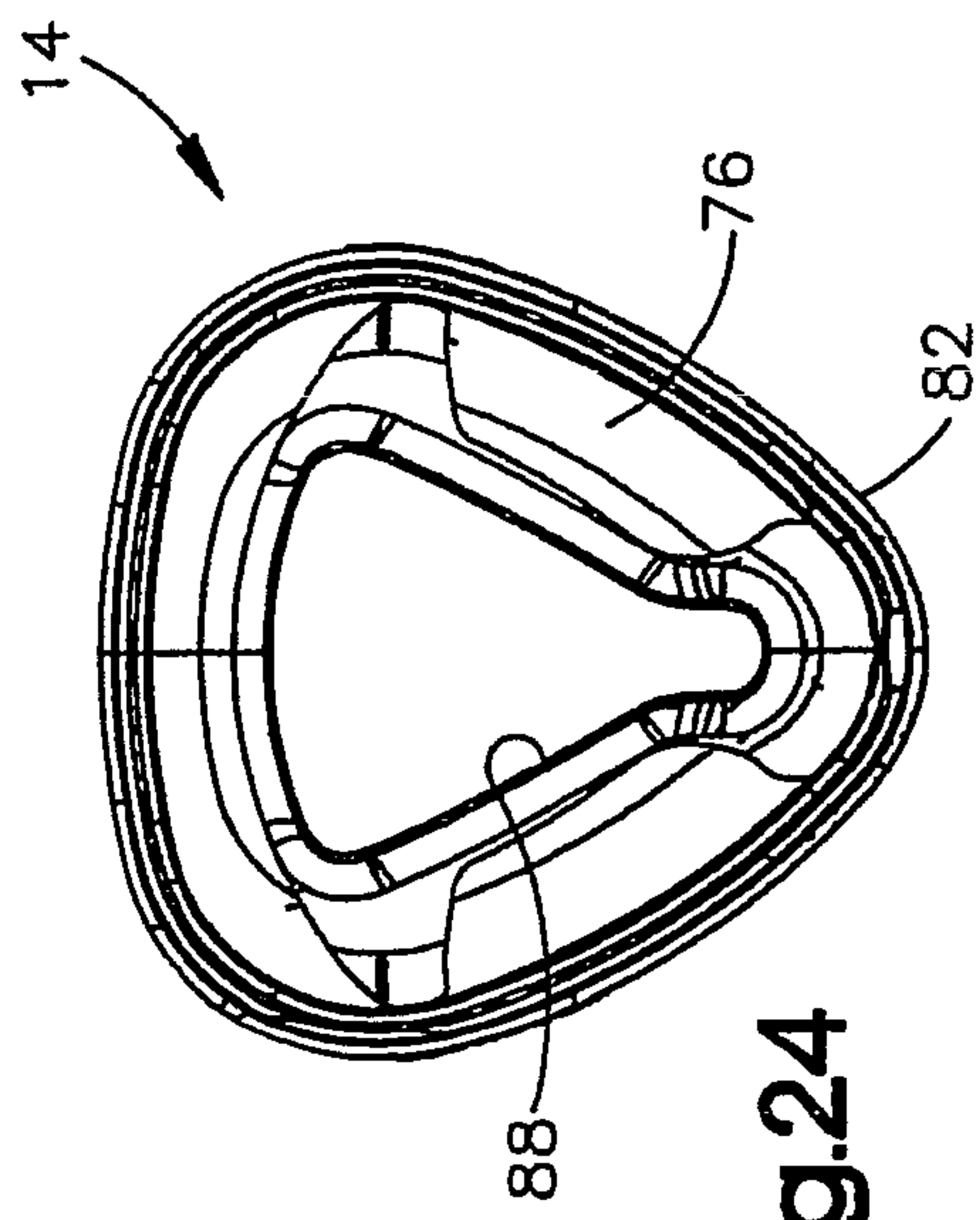

Fig.24

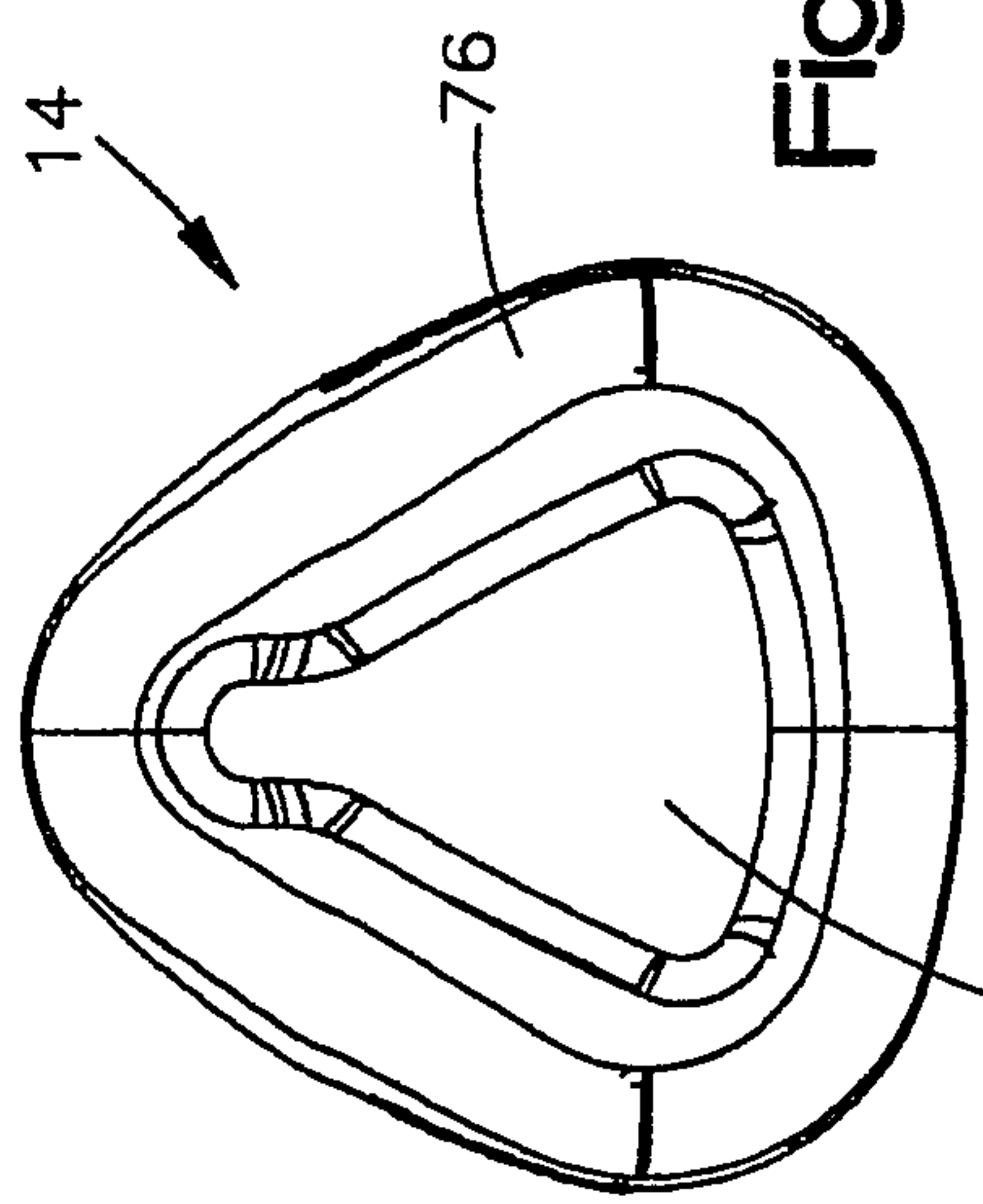

Fig.28

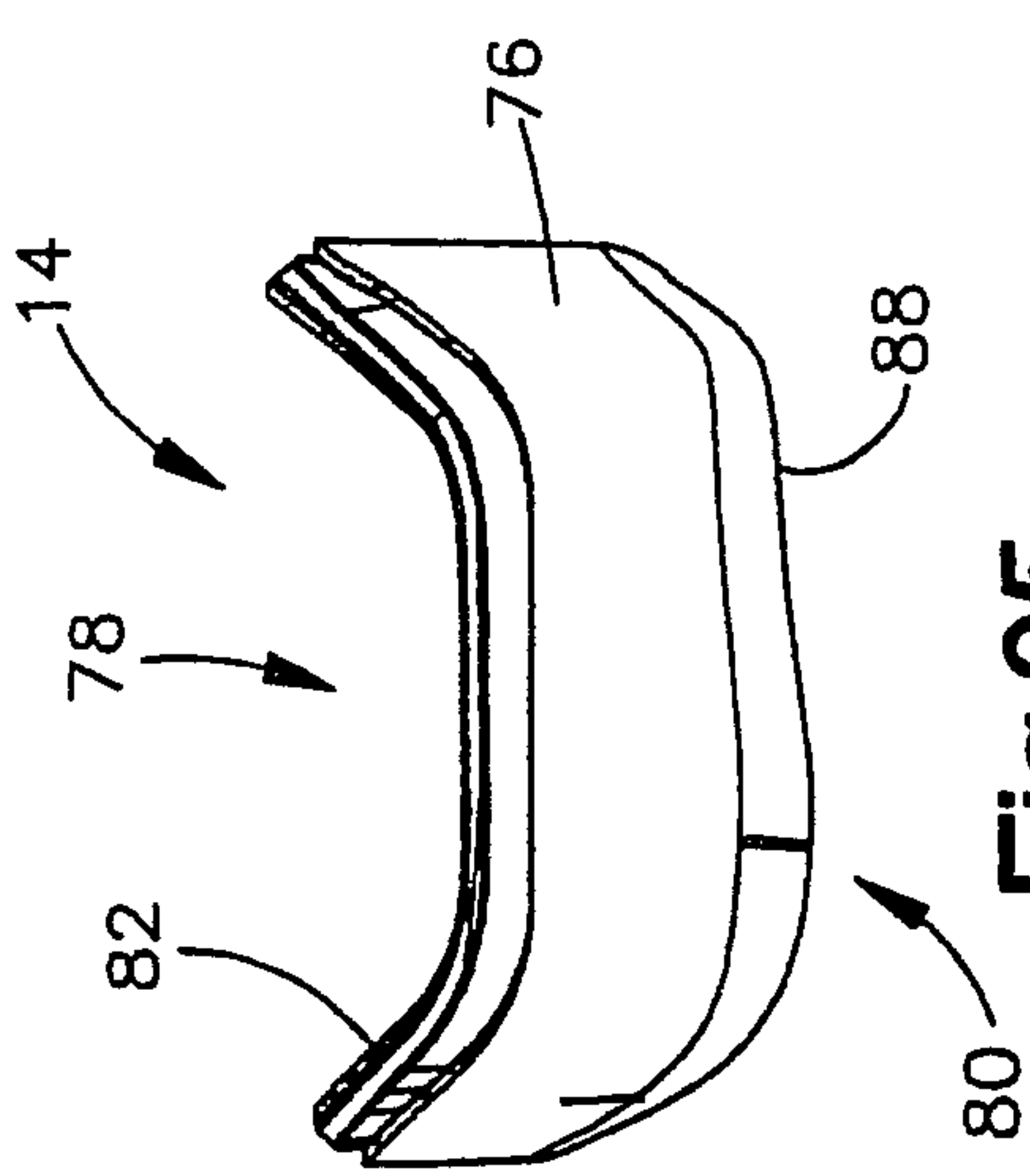

Fig.25

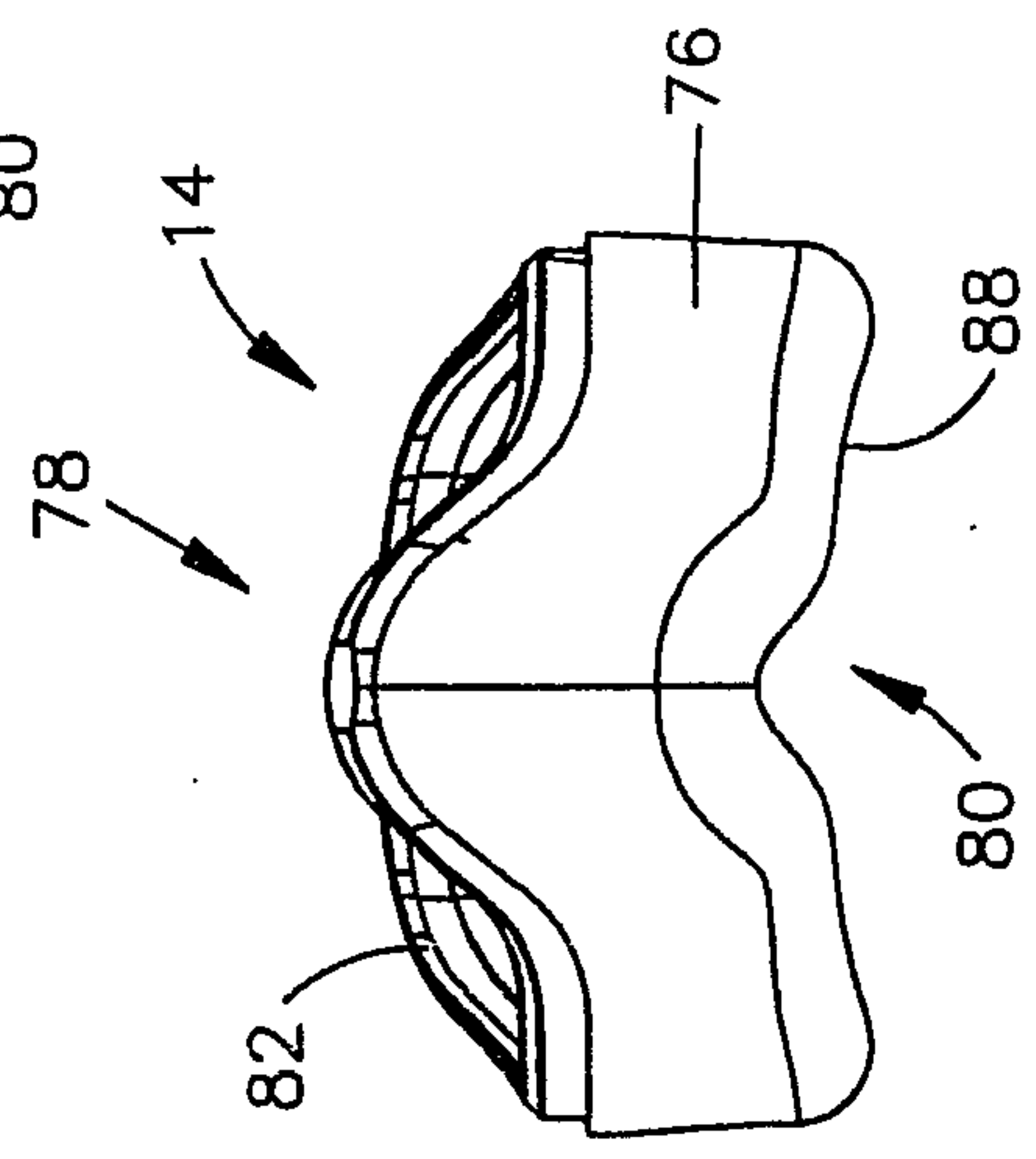

Fig.26

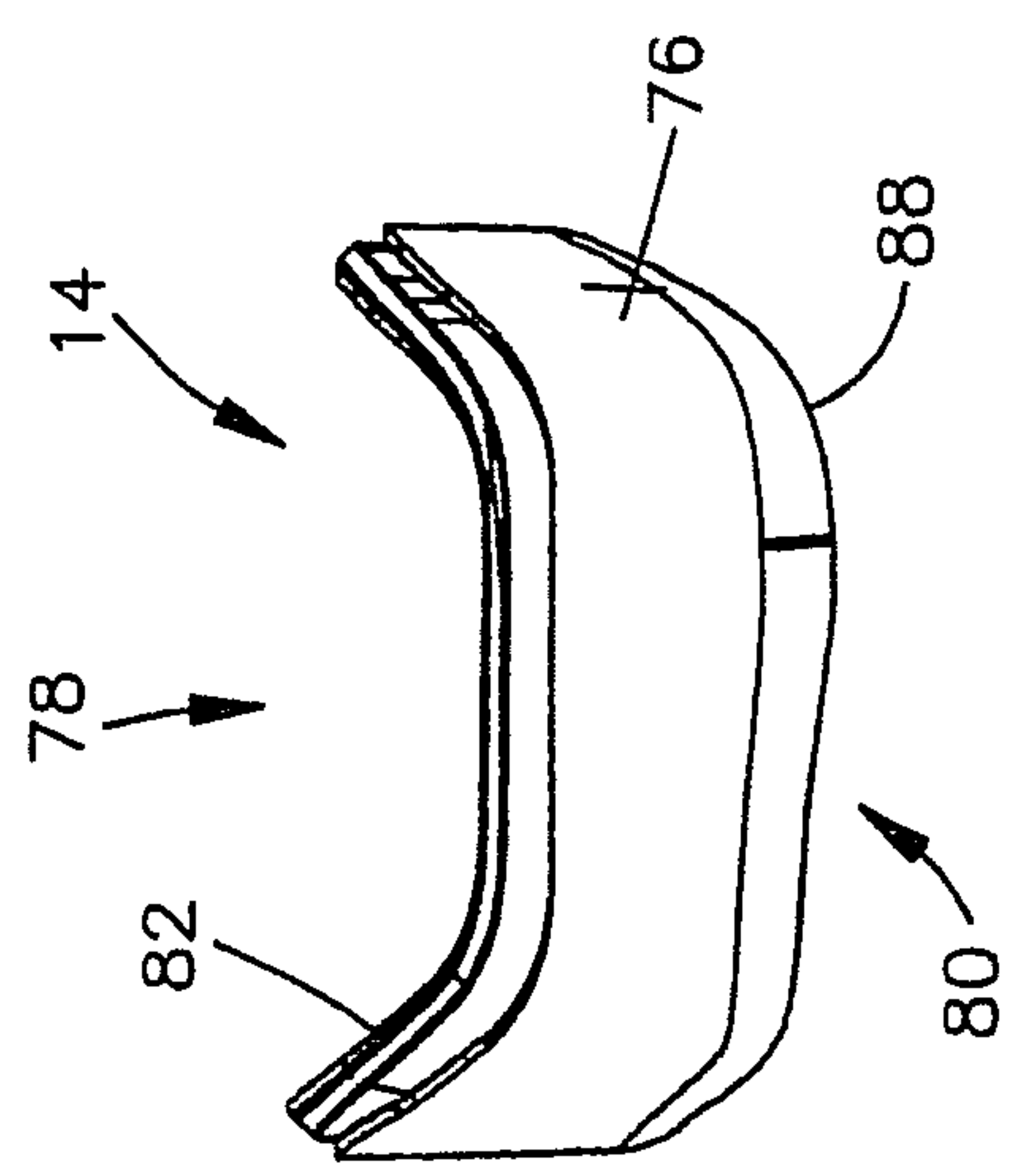
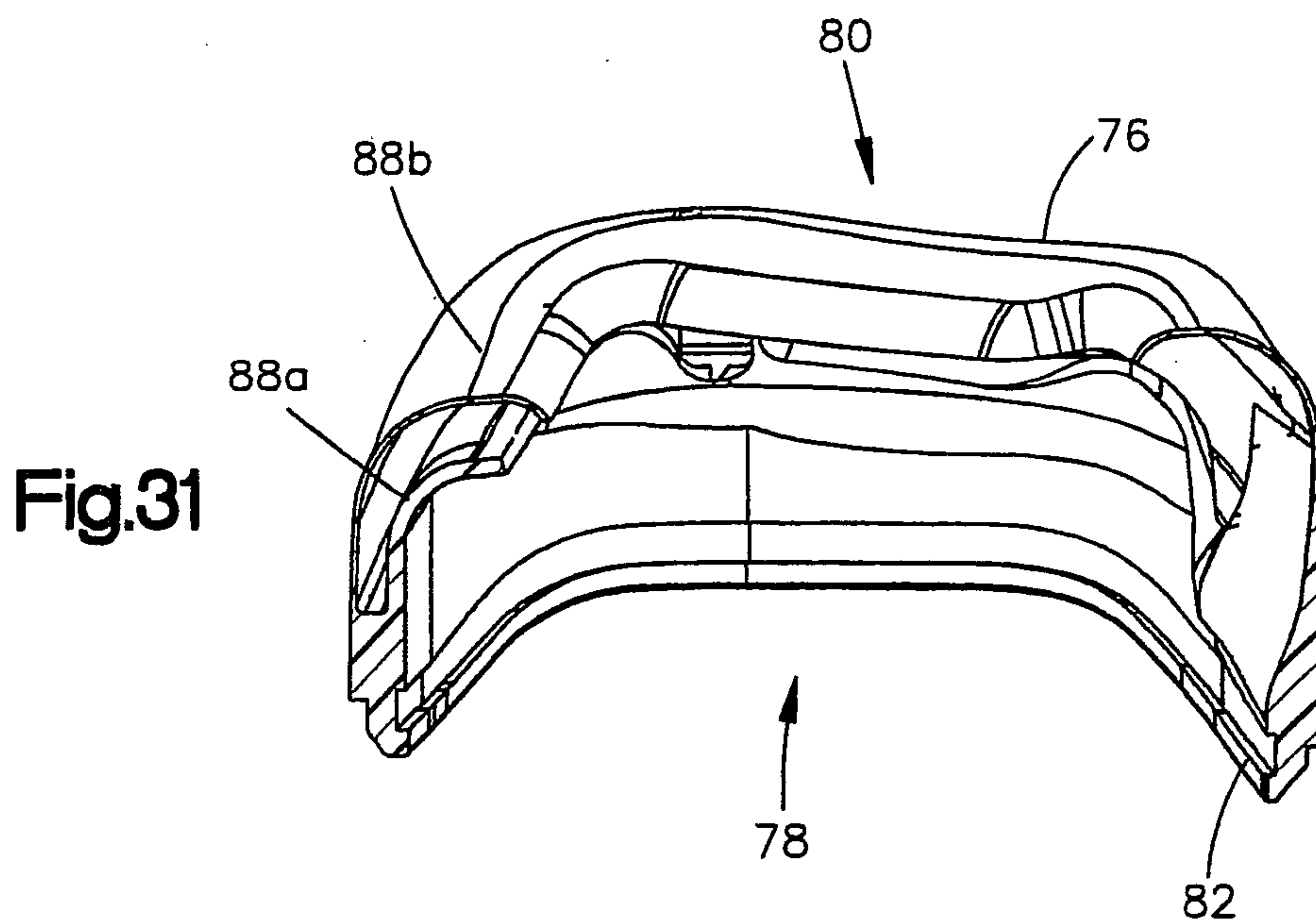
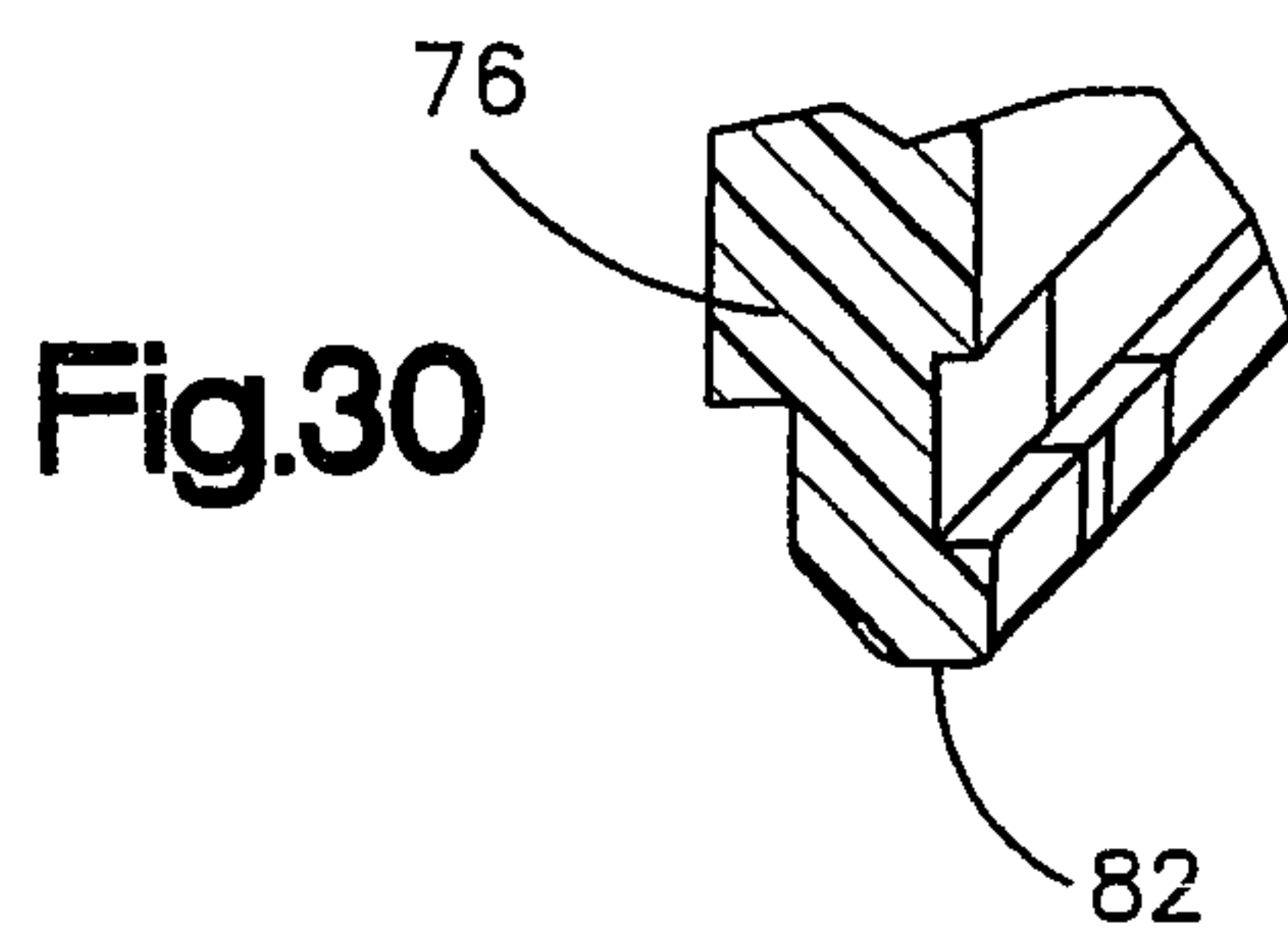
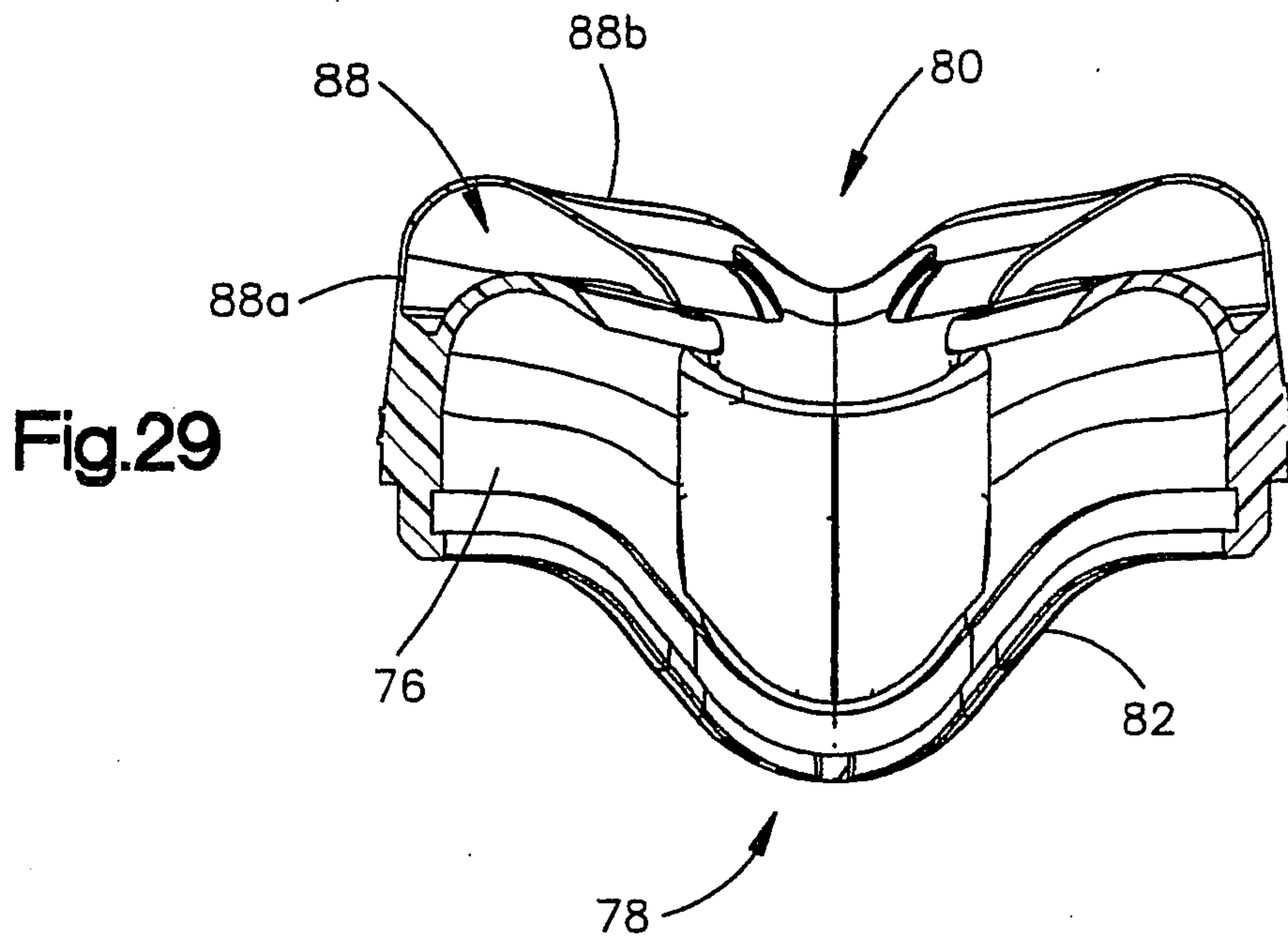
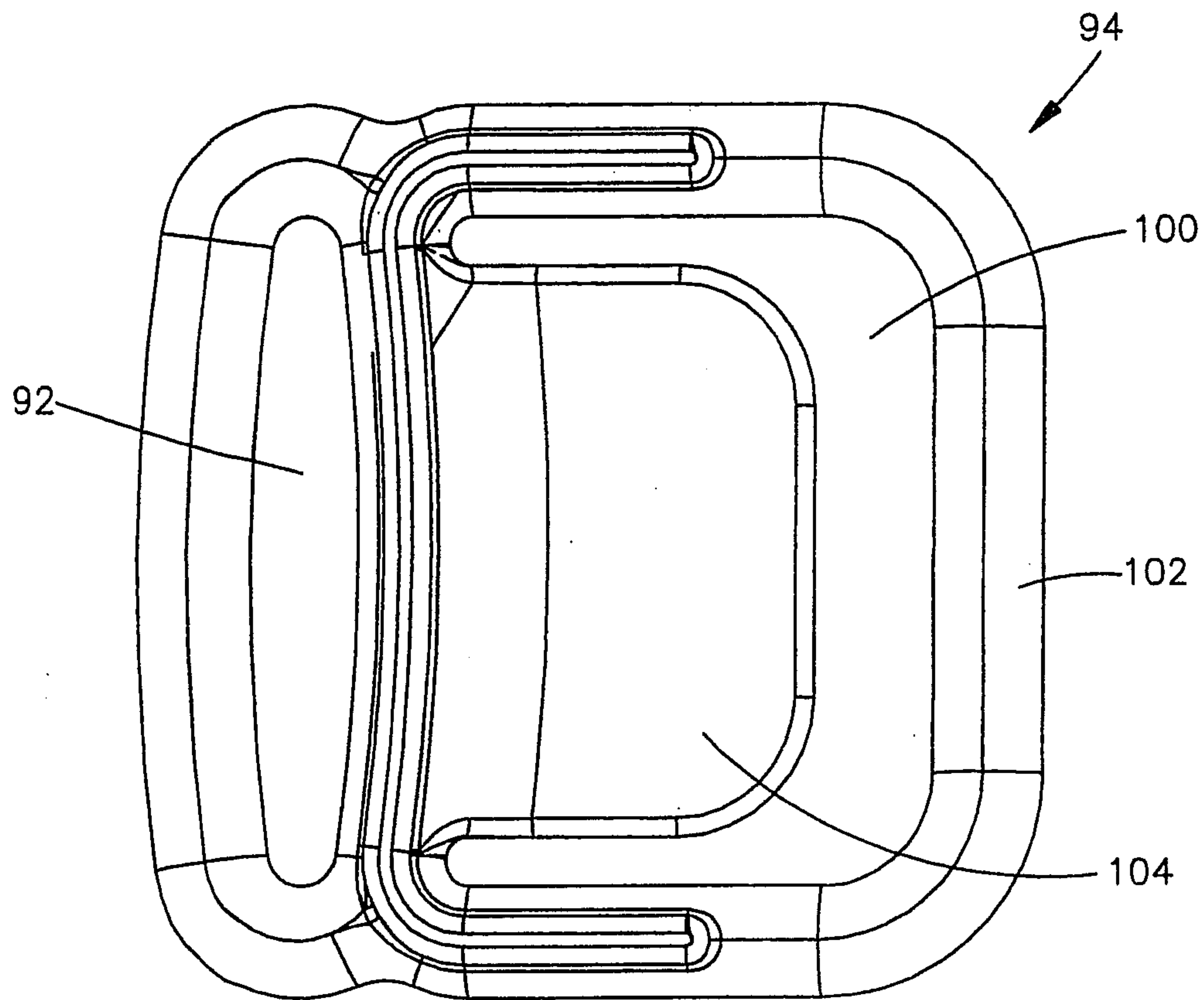

Fig.27







**Fig.32**

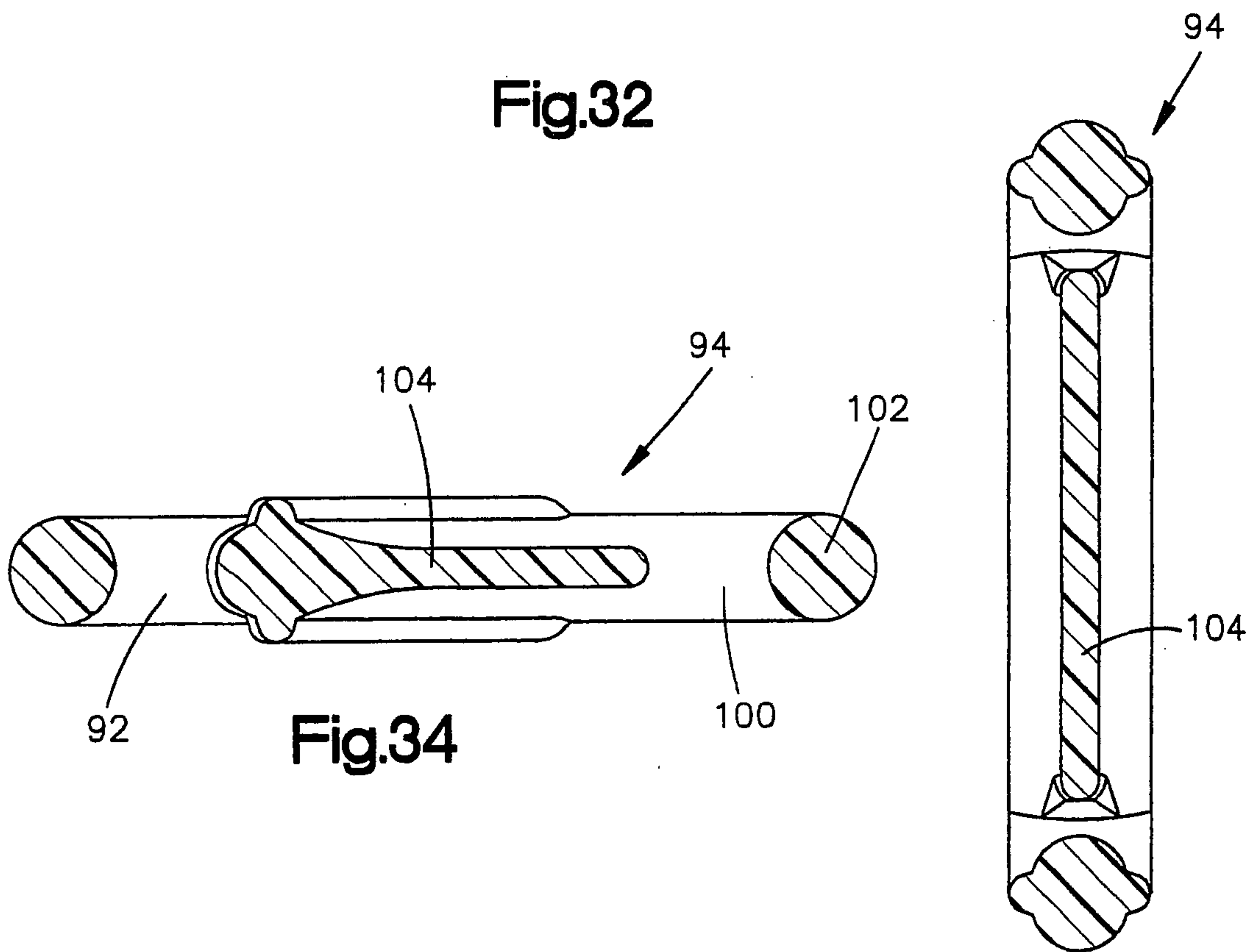

**Fig.34**

**Fig.33**

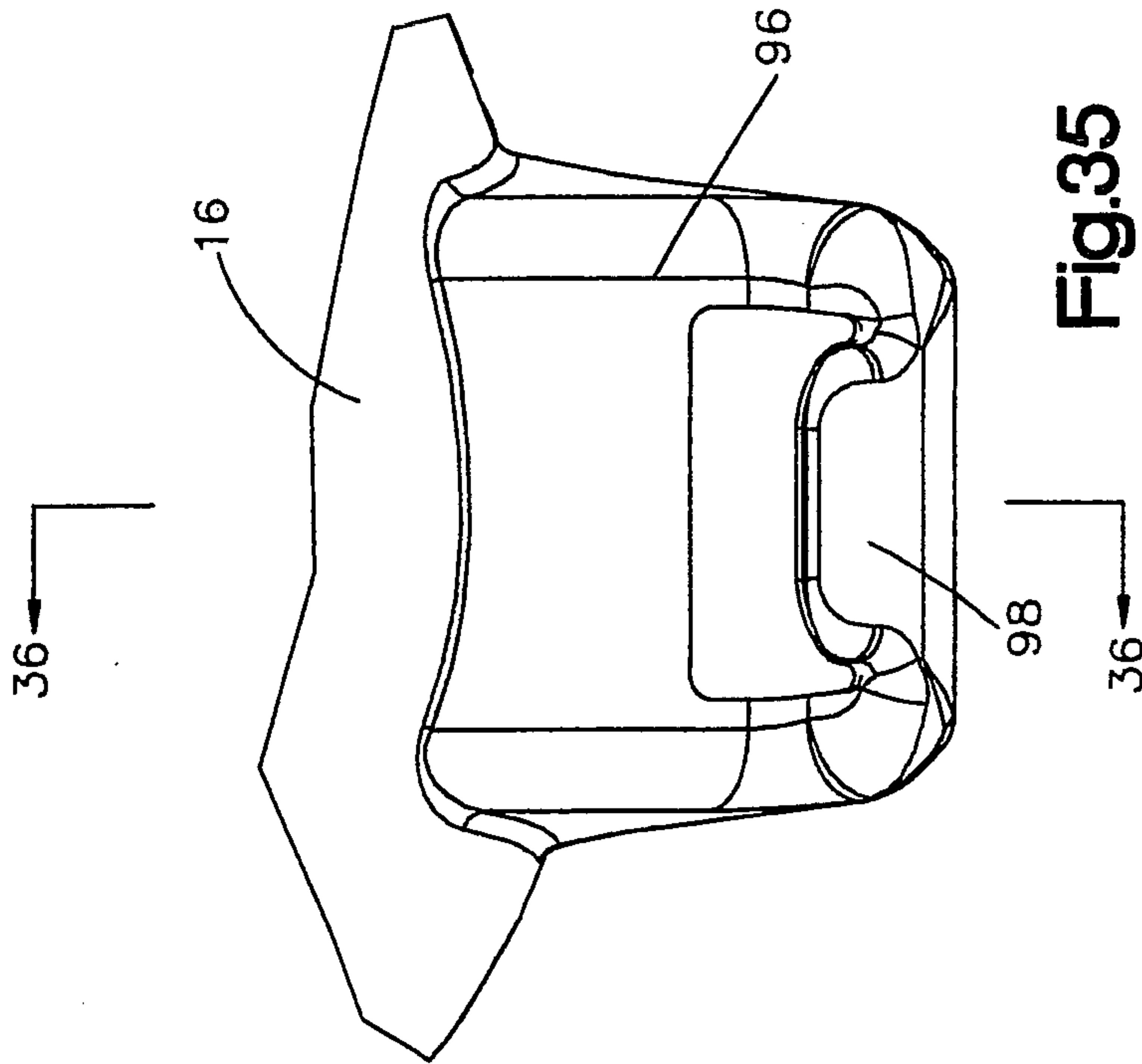

Fig.35

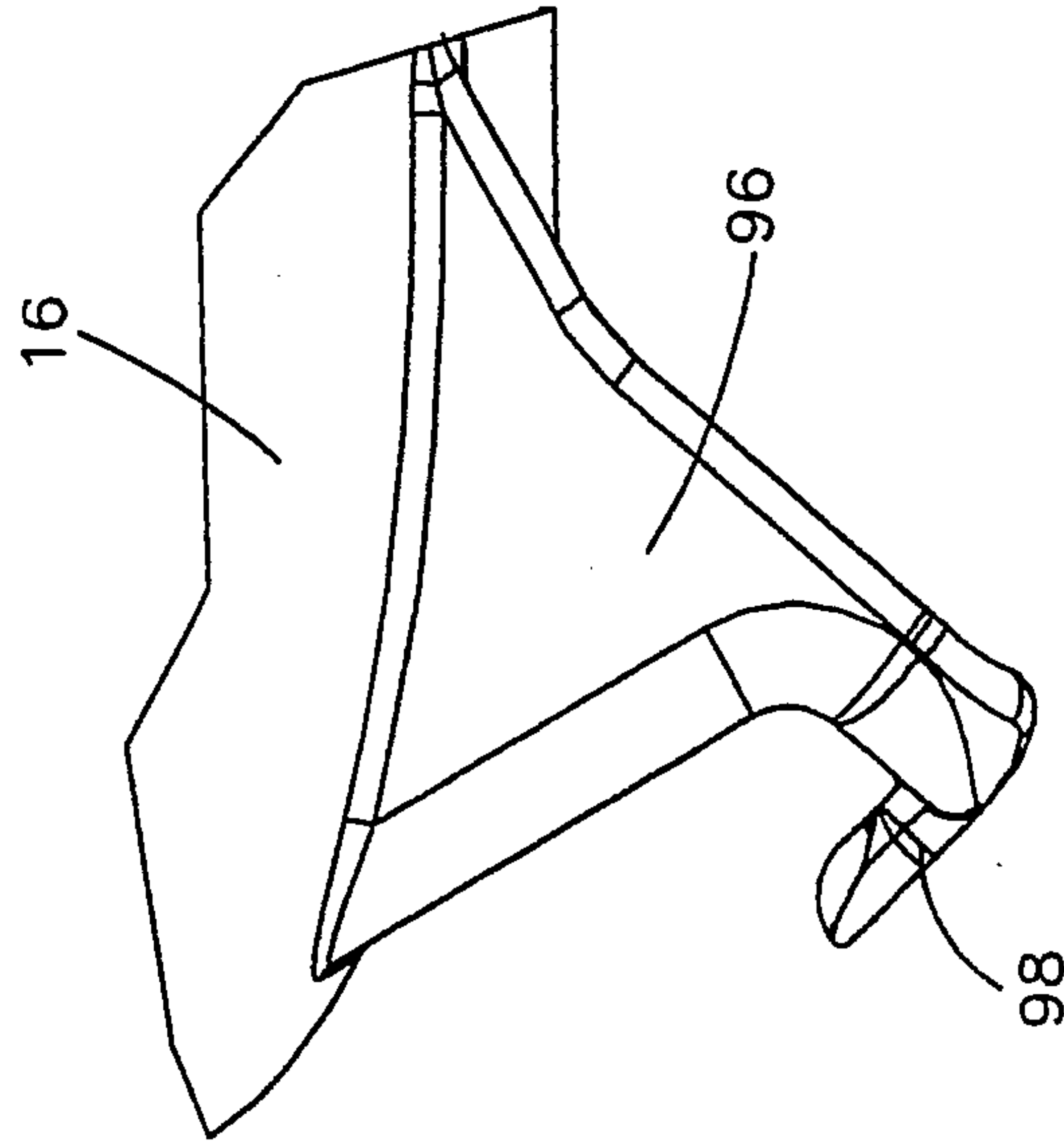

Fig.36

