

B. E. OSBORN.
CONDUIT ELECTRIC RAILWAY SYSTEM.

No. 549,580.

Patented Nov. 12, 1895.

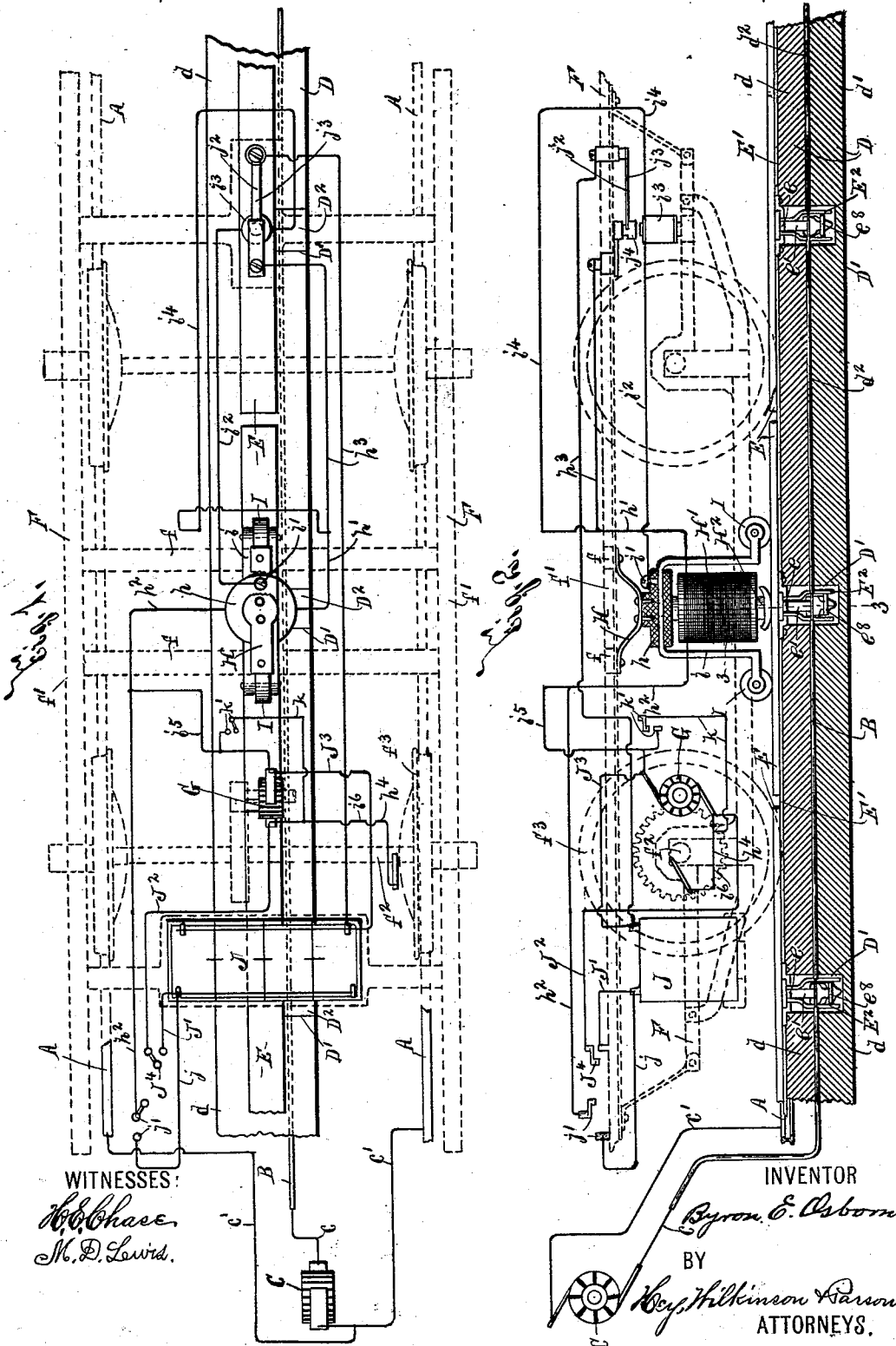

WITNESSES:
H. C. Chase
M. D. Lewis

INVENTOR
Byron E. Osborn
 BY
Wm. H. Wilkinson & Parsons
 ATTORNEYS.

B. E. OSBORN.
CONDUIT ELECTRIC RAILWAY SYSTEM.

No. 549,580.

Patented Nov. 12, 1895.

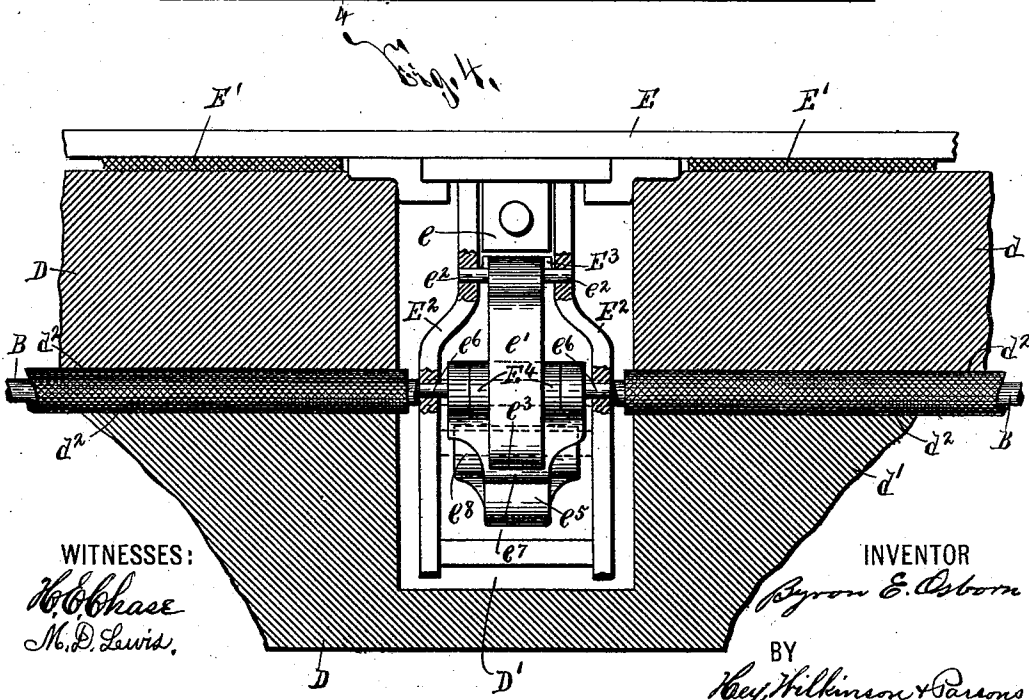
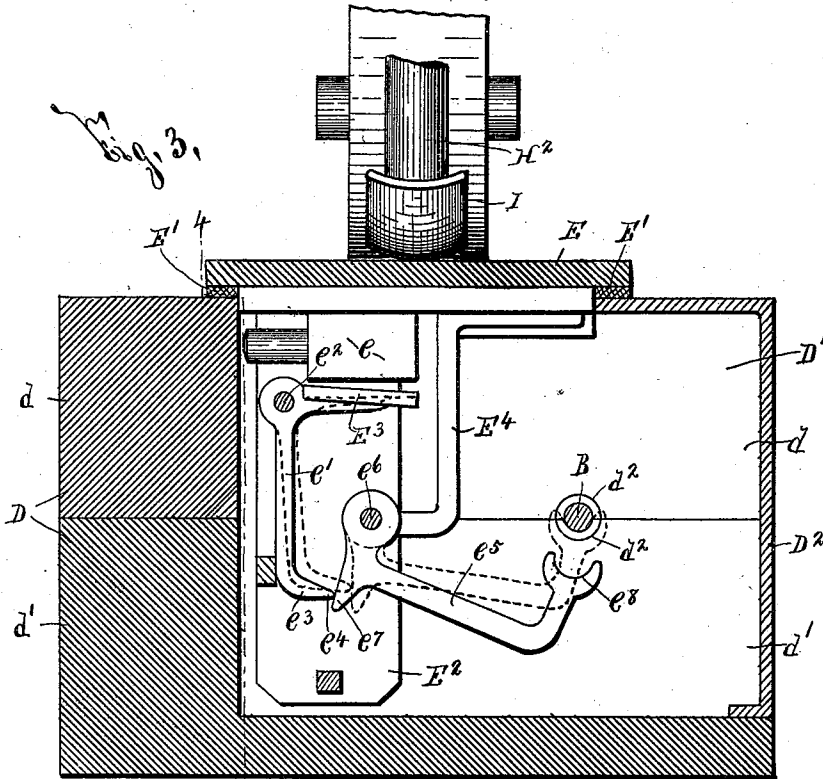

WITNESSES:
M. Chase
M. D. Lewis

INVENTOR
Byron E. Osborn
 BY
Key, Wilkinson & Parsons
 ATTORNEYS.

UNITED STATES PATENT OFFICE.

BYRON E. OSBORN, OF AUBURN, NEW YORK.

CONDUIT-ELECTRIC-RAILWAY SYSTEM.

SPECIFICATION forming part of Letters Patent No. 549,580, dated November 12, 1895.

Application filed July 14, 1894. Serial No. 517,511. (No model.)

To all whom it may concern:

Be it known that I, BYRON E. OSBORN, of Auburn, in the county of Cayuga, in the State of New York, have invented new and useful
5 Improvements in Electric-Railway Systems, of which the following, taken in connection with the accompanying drawings, is a full, clear, and exact description.

My invention relates to improvements in
10 electric-railway systems, and particularly to that class thereof provided with a main or power conductor for conveying an electric current to a terminal or trolley wheel movable along the railway, and has for its object
15 the production of a practical and simple device, which obviates the use of an elevated trolley-wire, the necessity of forcing a movable terminal or trolley wheel into contact with a main conductor, and the liability of
20 contact of persons or animals with the main conductor, and their consequent subjection to an electric shock, which is often fatal.

To this end it consists, essentially, in a main conductor depressed beneath the surface of the road-bed, a series of secondary conductors above the main conductor electrically disconnected therefrom, a vehicle or car movable along the main conductor and provided with an electrically-operated device and a
30 terminal for making contact with the secondary conductors, connected to said device for conveying the current therefrom, and an electric magnet supported by the vehicle or car for automatically connecting the main and
35 secondary conductors.

The invention also consists in the general construction and arrangement of its component parts, all as hereinafter more particularly described, and pointed out in the claims.

40 In describing this invention, reference is had to the accompanying drawings, forming a part of this specification, in which like letters indicate corresponding parts in all the views.

45 Figures 1 and 2 are respectively top plan and side elevation of a portion of a railway system constructed in accordance with my invention, the truck of a car or other vehicle being indicated by dotted lines as operatively
50 mounted upon the rails of the system for supporting the parts of my invention designed to be carried by a movable vehicle or car. Fig.

3 is a transverse vertical sectional view taken on line 3 3, Fig. 2; and Fig. 4 is a longitudinal vertical sectional view taken on line 4 4, Fig. 3.

It is well known that electric-railway systems are provided with main or power conductors, which are usually either elevated above the road-bed or depressed beneath the same. Considerable difficulty is experienced in providing simple and practical means for conveying the current from the depressed conductors to a passing vehicle or railway-car, and there is more or less liability of the entrance of foreign matters within the conduits for the depressed conductors, and of the contact of persons or animals with such conductors, whether elevated or depressed.

My present invention is so constructed that a passing vehicle or railway-car is movable along a series of normally insulated or electrically disconnected secondary conductors of less length than the vehicle or car, and is automatically connected to the secondary conductor beneath the vehicle or car, thus obviating all liability of the subjection of persons or animals to an electric shock when passing over the road-bed of the railway system, as they can only engage the normally insulated or electrically disconnected secondary conductors.

A A represent the rails of my improved railway system, which each preferably consists of a series of sections electrically connected in the usual manner, so as to operate as a ground-conductor.

B is a main or power conductor interposed between the rails A A, and C is a dynamo having one pole suitably connected, as by a wire *c*, to the conductor B, and its other pole similarly connected to the rails A A, as by wires *c'*. The dynamo C is arranged at any convenient station along the railway, and the current generated thereby passes along the conductor B to the moving vehicle or car upon the rails A A, as presently described, and then returns along the rails A A to said dynamo.

The conductor B is supported in any suitable insulating casing D, which preferably consists of separable sections *d d'*, composed of wooden planks or other similar material, and having their adjacent faces firmly secured

together in any well-known manner. The sections d d' of the casing D are formed with longitudinal grooves d^2 in their adjacent faces for receiving the conductor B, and are formed at intervals with pockets or chambers D', provided with removable walls D², of suitable construction. It is thus apparent that, although the greater portion of the conductor B is permanently insulated, the portions thereof arranged at intervals within the pockets D' are exposed.

Arranged lengthwise above the conductor B, and preferably above the upper section d of its insulating casing D, are a series of secondary conductors E, which are electrically disconnected from each other and said conductor B. The secondary conductors E, which may be utilized as top walls for the pockets or chambers D', and may be separated from the adjacent wall of the casing D by insulating packing E', are formed of suitable material susceptible to magnetism, and are provided on their under faces with depending projections or pole-pieces e that are preferably secured to or formed integral with the upper extremity of a removable frame E², having the opposite longitudinal edges of its upper extremity provided with engaging shoulders, suitably supported by shoulders on the lower faces of the conductors E, as clearly seen at Fig. 3.

Arranged in proximity to the projections or pole-pieces e are a series of armatures E³ mounted on the upper ends of supports or levers e' , pivoted at e^2 to the frame E², and having depending arms e^3 , provided with laterally-extending shoulders e^4 .

Interposed between the supports e' and the conductor B are a series of connecting-pieces e^5 , consisting preferably of levers pivoted at e^6 to the frame E², and having shoulders e^7 arranged to make contact with the shoulders e^4 of the armature-supports e' . The opposite end of the connecting-pieces e^5 are provided with upwardly-extending arms e^8 , having their free ends movable into engagement with the under face of the conductor B. Suitable fixed electric conducting-pieces E¹ connect the pivots e^6 with the secondary conductors E for conveying the current from one to the other. The armatures E³ are normally disconnected from the projections or pole-piece e , and the connecting-pieces e^5 are normally disconnected from the conductor B. If desired, the wall D² of any of the pockets or chambers D' may be removed, and the frame E², carrying the corresponding armature E³ and connecting-piece e^5 , may be removed for examination, repair, or replacement of said parts.

As a passing vehicle or railway-car passes over the road-bed of my improved railway system, the secondary conductors E are successively magnetized, as will be presently described, and consequently the depending projections or pole-pieces e successively attract the corresponding armatures E and rock the

supports e' upon their pivots e^2 . As the supports e' are rocked, as described, the connecting-pieces e^5 are also rocked on their pivots e^6 , and the free ends of said connecting-pieces make contact with the conductor B and electrically connect the corresponding secondary conductors thereto.

At Figs. 1 and 2 I have illustrated by dotted lines the truck F of a vehicle or railway-car as mounted upon the rails A A, and, as will be readily understood, this truck supports an electrically-operated device as a motor G for propelling the same. The truck F is also provided with a suitable yielding support H, here shown as a spring having its opposite ends secured to cross-bars f , having their opposite ends attached to the body-supporting bars f' to the truck.

Secured to the yielding support H is an insulating piece or frame h , which supports a magnet H' and terminals or trolley-wheels I I. The pole-piece H² of the magnet H' moves in close proximity to or makes contact with the secondary conductors E for magnetizing the same and effecting the operation of the armatures E³, as previously described. This pole-piece may be of any desirable form, size, and construction, and is here shown as provided with a curved lower face and upwardly-extending extremities for facilitating its ready passage along the conductors E.

I preferably use two terminals or trolley-wheels I I, arranged in front and at the rear of the magnet H', and preferably support these terminals or wheels upon an electric frame i , having its opposite extremities provided with depending arms arranged one in advance of the other for supporting the trolley-wheels and having its central portion passed through the insulating-frame h and connected by a screw or other conductor i^1 to a wire or conductor i^2 , connected to a magnet i^3 , which is connected by a wire or conductor i^4 to a wire h' , connected to the magnet H', previously described. A wire h^2 extends from the magnet H' and is connected by a wire or conductor i^5 to one pole of the motor G. The opposite pole of the motor G is connected by a wire or conductor i^6 to one of the axles f^2 of the truck F, and the usual wheels f^3 upon the axle f^2 connect said axle to the rails A A. It is thus apparent that, when a secondary conductor E, connected to the conductor B, as previously described, is engaged by one or both of the terminals or trolley-wheels I, that the current passes through the magnets H' i^3 , and the wires or conductors i^2 i^4 h' i^5 i^6 to the motor G and thence to the rails A, and that the magnets H' i^3 and the motor G are energized. As previously stated, the magnet H' operates to electrically connect to the conductor B the secondary conductor E engaged with its pole-piece H², and the motor G operates to propel the vehicle or railway-car provided therewith. It is evident, however, that instead of a motor G any other suitable electrically-operated device may be used.

In order to energize the magnet H' when the vehicle commences its movement, and before the secondary conductor beneath the vehicle is electrically connected to the main conductor B, I temporarily utilize a source of electric energy J as a storage-battery connected by wires or conductors j , h^2 , h' , and h^3 to the magnet H' . The wires or conductors j h^2 are normally disconnected until connected by a suitable switch j' , which may be of any desirable form, size, and construction. The wires or conductors h' h^3 are normally connected by a switch j^2 , also of any desirable form, size, and construction, and provided with a movable piece j^3 , having an armature j^4 secured at its free end and arranged opposite to the pole-piece of the magnet i^3 . As the switch j' is closed for completing the circuit from the source of electric energy J , the current passes through the wires j , h^2 , h' , and h^3 and energizes the magnet H' , whereupon its pole-piece H^2 magnetizes the secondary conductor engaged therewith, and said conductor is electrically connected to the conductor B. The current from the conductor B then passes, as previously described, to the motor G , and energizes the magnet i^3 , which attracts the armature j^4 , and automatically breaks the circuit connecting the source of electric energy J with the magnet H' , and, as previously stated, the current from the conductor B then operates to continuously energize the magnet H' .

When, from any cause, the current from the conductor B is insufficient or the circuit to the motor G is broken, the magnet i^3 is not energized sufficiently to attract the armature j^4 and the circuit from the source of energy J to the magnet H' is completed with the exception of the switch j' . In again starting the vehicle or car, it becomes necessary to close the switch j' for connecting the source of electric energy J with the magnet H' and effecting electric connection of the corresponding secondary conductor with the conductor B, and when said connection is established the switch j^2 operates automatically to break the circuit from the source of electric energy J . The source of electric energy J may also be connected directly with the motor or other device G , if desired, by conductors J' J^2 J^3 , and a switch J^4 of any suitable construction. It is also evident that, when desired to stop the vehicle or car, the wire i^5 extending to the motor G may be first connected by a wire k and a switch k' to the wire i^6 , leading to the axle f^2 , and the magnet H' will not then lose its efficiency.

As will be readily understood upon reference to the foregoing description and the accompanying drawings, when a railway system is provided with my invention the main conductor is depressed beneath the surface of the road-bed and is thoroughly insulated, so that contact therewith is absolutely impossible; a series of secondary conductors electrically disconnected from each other and

from the main conductor are arranged along the surface of the road-bed between the rails, a vehicle or railway car upon the rails automatically connects to the main conductor the secondary conductor directly beneath the vehicle or car, and no current is transmitted to the secondary conductors in advance or at the rear of the vehicle or railway-car. All liability of injury to persons or animals by contact with the conductors of the system is therefore entirely obviated, and the necessity for a lengthwise slot between the rails for permitting access of a terminal or trolley-wheel to a depressed conductor supported within a conduit is also entirely obviated. The connection of the vehicle or railway-car to the secondary conductors is under the control of the operator, and the car may be stopped or started at will. It is evident, however, that my invention is not limited to any particular form of electrically-operated device actuated by the main conductor, the exact construction of mechanism for connecting the secondary and main conductors, or the source of electric energy for effecting the initial connection of said conductors when the vehicle or railway-car is first started.

As it is evident from the foregoing that the exact construction and arrangement of the parts of my invention may be somewhat varied without departing from the spirit thereof, I therefore do not herein specifically limit myself to such construction and arrangement.

Having thus fully described my invention, what I claim as new, and desire to secure by Letters Patent, is—

1. In an electric railway system, the combination of a main conductor, a series of secondary conductors electrically disconnected from the main conductor and provided with pendent pole pieces, movable connecting pieces for connecting the main and secondary conductors, movable levers provided with armatures movable toward and away from said pole pieces and arms for actuating said connecting pieces, and a vehicle movable along the main conductor and provided with a magnet for magnetizing the secondary conductors and their pole pieces, substantially as and for the purpose set forth.

2. In an electric railway system, the combination of a main conductor, the separate sections of a casing for receiving and insulating said conductor, said casing being provided at intervals with a series of pockets or chambers, a series of secondary conductors electrically disconnected from the main conductor, and provided with depending pole pieces, movable connecting pieces mounted in said pockets or chambers for connecting the main and secondary conductors, movable levers also mounted in said pockets and provided with armatures movable toward and away from the pole pieces and arms for actuating the connecting pieces and a vehicle movable along the main conductor and provided with a magnet for magnetizing the sec-

ondary conductors and their pole pieces, substantially as and for the purpose specified.

3. In an electric railway system, the combination of a main conductor, a series of secondary conductors electrically disconnected from the main conductor, pivoted connecting pieces for connecting the main and secondary conductors, pivoted armatures having laterally extending shoulders for actuating said connecting pieces, and a vehicle movable along the main conductor and provided with mechanism for forcing said armatures to operative position, substantially as described.

4. In an electric railway system, the combination of a main conductor, a series of secondary conductors electrically disconnected from the main conductor, and provided with pendent pole pieces, movable connecting pieces for connecting the main and secondary conductors, movable levers provided with armatures movable toward and away from the pole pieces, and arms for actuating the connecting pieces; with a vehicle movable along the main conductor and provided with a magnet for successively actuating said armatures, a source of electric energy and a circuit supported by the vehicle for energizing said magnet, and means mounted on the vehicle and connected to said secondary conductors and circuit for automatically breaking the circuit, substantially as and for the purpose described.

5. In an electric railway system, the combination of a main conductor, a series of secondary conductors electrically disconnected from the main conductor, and armatures arranged in proximity to the disconnected conductors for connecting the main and secondary conductors; with a vehicle movable along the main conductor and provided with a substantially upright magnet having a pole piece at its lower extremity movable successively along the secondary conductors for actuating said armatures, a source of electric energy, and a circuit supported by the vehicle for energizing said magnet, and means mounted on the vehicle and connected to said secondary conductors and circuit for automatically breaking the circuit, substantially as and for the purpose described.

6. In an electric railway system, the combination of a main conductor, a series of secondary conductors electrically disconnected from the main conductor and provided with pendent pole pieces, movable connecting pieces for connecting the main and secondary conductors, movable levers provided with armatures movable toward and away from the pole pieces, and arms for actuating the connecting pieces; with a vehicle movable along the main conductor and provided with a substantially upright magnet having a pole piece

at its lower extremity formed with upturned front and rear extremities and movable successively along the secondary conductors for actuating said armatures, a yielding support for the magnet, a source of electric energy and a circuit supported by the vehicle for energizing said magnet, and means mounted on the vehicle and connected to said secondary conductors and circuit for automatically breaking the circuit, substantially as and for the purpose set forth.

7. In an electric railway system, the combination of a main conductor, a series of secondary conductors electrically disconnected from the main conductor and provided with pendent pole pieces, movable connecting pieces for connecting the main and secondary conductors, movable levers provided with armatures movable toward and away from the pole pieces, and arms for actuating the connecting pieces; with a vehicle movable along the main conductor and provided with a substantially upright magnet having a pole piece at its lower extremity movable along the secondary conductors for successively actuating said armatures, a source of electric energy and a circuit supported by the vehicle for energizing said magnet, a terminal movable along the secondary conductors for making contact therewith, a magnet connected to the terminal for breaking said circuit and an electrical connection between the terminal and the substantially upright magnet for energizing the same, substantially as and for the purpose specified.

8. In an electric railway system, the combination of a main conductor, a series of secondary conductors electrically disconnected from the main conductor, and armatures for connecting the main and secondary conductors; with a vehicle movable along the main conductor, a magnet for successively actuating said armatures, an insulating frame supported by the vehicle, an electric conducting frame having its central portion supported by the insulating frame and its opposite extremities provided with depending arms arranged one in advance of the other, trolley wheels supported by the lower ends of said arms and movable along the secondary conductors, and electrically connected to the magnet, substantially as and for the purpose described.

In testimony whereof I have hereunto signed my name, in the presence of two attesting witnesses, at Auburn, in the county of Cayuga, in the State of New York, this 4th day of July, 1894.

BYRON E. OSBORN.

Witnesses:

GEORGE W. BENHAM,
FREDERIC COSSUM.