



(12) PATENT

(19) NO

(11) 337633

(13) B1

NORWAY

(51) Int Cl.

G01V 1/38 (2006.01)
B63B 21/66 (2006.01)

Norwegian Industrial Property Office

(21)	Application nr.	20150200	(86)	International Filing Date and Application Number
(22)	Date of Filing	2015.02.11	(85)	Date of Entry into National Phase
(24)	Date of Effect	2015.02.11	(30)	Priority
(41)	Publicly Available	2016.05.18		
(45)	Granted	2016.05.18		
(73)	Applicant	inApril AS, Per Kroghs vei 4, 1065 OSLO, Norge		
(72)	Inventor	Vidar Hovland, Skyttafaret 26, 1481 HAGAN, Norge Vidar Pedersen, Bingsgate 3, 1606 FREDRIKSTAD, Norge Malte Sensson, Näckens väg 1, SE-65345 KARLSTAD, Sverige		
(74)	Agent or Attorney	Bryn Aarflot AS, Postboks 449 Sentrum, 0104 OSLO, Norge		
(54)	Title	A device for attaching a seismic node to a cable, a seismic node, as well as a method for deployment and retrieval of seismic nodes attached to a cable		
(56)	References Cited:	US 6024344 A US 2015003917 A1 US 5456199 A US 3209718 A		
(57)	Abstract			

It is described an attachment device (2) for attaching a seismic node to a cable (1), the attachment device comprising an in-line fastening device (6) fastening the cable (1); and at least one locking device (3) securing the cable (1) in the at least one in-line fastening device (6). The locking device (3) prevents the cable (1) from escaping the fastening device (6). A seismic node and a method for deployment and retrieval of a number of seismic nodes are also described.

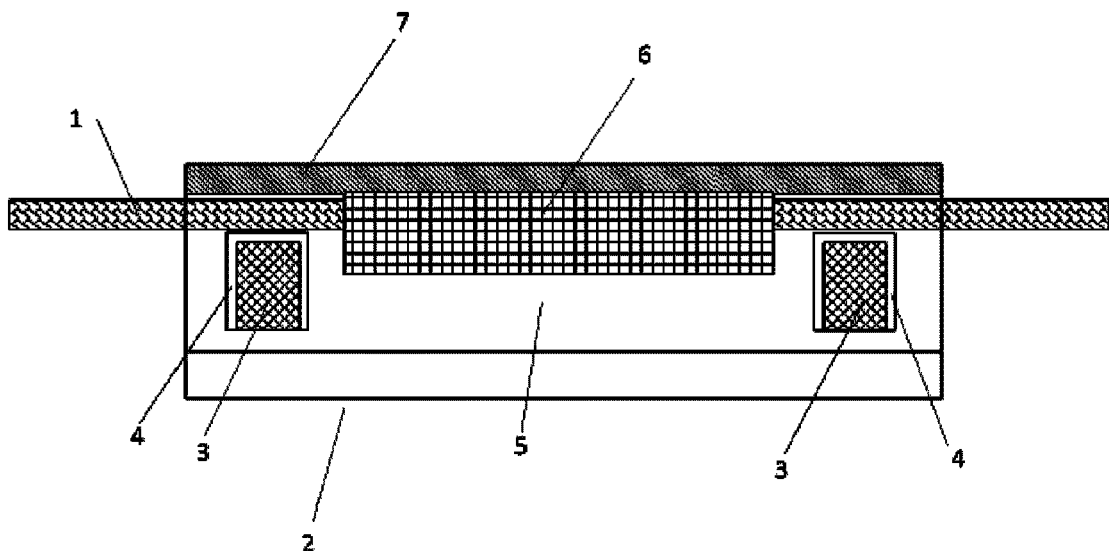

INTRODUCTION

The present invention concerns a device for attaching a seismic node to a cable, a seismic node, as well as a method for deployment and retrieval of seismic nodes attached to a cable.

5 BACKGROUND

Seismic surveying is performed using a number of different solutions. Example solutions are e.g. seismic streamer cables towed behind a vessel, ocean bottom seismic cables, or autonomous seismic recorders/nodes arranged on the ocean bottom. The autonomous seismic recorders may be individually placed on the
10 ocean bottom by e.g. remotely operated vehicles, or by dropping the seismic recorders in the sea from a vessel. Alternatively, the autonomous seismic recorders may be arranged on the ocean bottom attached to a cable deployed from a vessel. In the prior art solutions, the seismic recorders are attached to the cable in predetermined positions along the cable defined by connection points on
15 the cable. There is a need for more efficient seismic surveying reducing the time and thereby costs involved.

SUMMARY OF THE INVENTION

The invention is conceived to solve or at least alleviate the problems mentioned
20 above.

In a first aspect the invention provides an attachment device for attaching a seismic node to a cable comprising at least one in-line fastening device for fastening the in-line fastening device to the cable; and at least one locking device
25 securing the cable in the at least one in-line fastening device.

The at least one in-line fastening device may be adapted to provide fastening by an in-line force of the cable. The at least one in-line fastening device may be adapted to provide increased fastening of the in-line fastening device to the cable
30 as the in-line forces from the cable increases. The at least one in-line fastening device may further comprise a number of oppositely arranged ridges for fastening of the in-line fastening device to the cable. In an embodiment at least two locking

devices may be provided, where a locking device is arranged on opposite sides of the at least one in-line fastening device. The at least one locking device may be adapted to be pushed open upon engagement with the cable, for thereby returning to a locking position securing the cable. The locking device may include a biased resilient member for returning the locking device to a locking position. The attachment device may comprise a housing having an opening at one end for receiving the cable, wherein the at least one in-line fastening device is arranged inside the housing facing the opening. The housing may comprise a back wall and a top part. The at least one in-line fastening device and the at least one locking device may be passive devices.

The invention also provides a seismic node comprising a device for attaching the seismic node to a cable as described above. The attachment device may be arranged on an upper side of the seismic node ensuring the front side of the node is facing down on the ocean bottom. The cable may be arranged in a non-centered position in the attachment device.

The invention further provides a method for deploying a number of seismic nodes as defined above into the sea, the method comprising: deploying a cable into the sea, attaching the seismic nodes to the cable during deployment, wherein each seismic node is attached to the cable by the following method: pushing the at least one locking device to an open position; inserting the cable passed the at least one locking device, whereby the at least one locking device returns to a locking position, and fastening the cable to the at least one in-line fastening device by the cable movement in a longitudinal direction of the cable.

A guiding tool may be used for bringing the cable and the at least one seismic node locking device towards each other before pushing the at least one locking device to an open position.

The invention also provides a method for retrieving a number of seismic nodes as described above, attached to a cable from the sea, the method comprising: retrieving the cable, detaching each of the seismic nodes from the cable during retrieval by: pushing the at least one locking device to an open position; moving

the cable passed the at least one locking device, whereby the at least one locking device returns to its closed position, and whereby the movement of the cable releasing the cable from the at least one in-line fastening device of the seismic node. A guiding tool may be used for pushing the at least one locking device to an open position.

The cable may be a rope or a wire. A guiding tool may be used for bringing the cable and the at least one seismic node locking device towards each other. The guiding tool may be in the form of a guiding wheel guiding the cable during deployment and retrieval of the cable.

The attachment device firmly attaches the seismic node to the cable and avoids in-line sliding along the cable without use of connection points along the cable. The seismic nodes are thus attached to a clean cable. A clean cable without connecting points results in a flexible solution with regard to where seismic nodes may be attached to the cable and also with respect to distances between the seismic nodes along the cable.

The attachment device for attaching a seismic node to a cable according to the invention enables a simple design without moving parts. The attachment device may also be constructed without use of metal avoiding corrosion. The attachment device is simple in construction, reliable and fast in operation and enables increased speed of the vessel during deployment and retrieval of the cable and seismic nodes. This result in better efficiency and thereby decreased costs due to the reduction in time spent on the seismic surveying operations.

BRIEF DESCRIPTION OF DRAWINGS

Embodiments of the invention will now be described with reference to the followings drawings, where:

Figure 1 is a schematic illustration of a vessel deploying a number of seismic nodes attached to a cable on the sea floor/ocean bottom.

Figure 1a is a schematic illustration in top view of an attachment device according to an embodiment of the present invention;

Figure 1b is a schematic illustration in top view of a an attachment device illustrating internal details of an embodiment of the attachment device from Figure 1a;

Figure 2 is a schematic illustration in side view of a seismic node with an attachment device from Figure 1a according to an embodiment of the invention;

5 Figure 3a is a schematic illustration in front view (in-line with the rope) of the seismic node with an attachment device from Figure 1a according to an embodiment of the invention;

Figure 3b is a schematic illustration in front view of the attachment device from Figure 3a on, with a locking device in a locked position after attachment of the seismic node to the cable according to an embodiment of the invention;

10 Figure 3c is a schematic illustration in front view of the attachment device from Figure 3a, with a locking device in an open position during detachment of the seismic node from the cable according to an embodiment of the invention.

15 DETAILED DESCRIPTION

The present invention will be described with reference to the drawings. The same reference numerals are used for the same or similar features in all the drawings and throughout the description.

20 Figure 1 illustrates a vessel deploying a number of seismic nodes 20 attached to a cable 1 on the ocean bottom. The seismic nodes are autonomous; i.e. seismic nodes contain a power source and memory for the recorded seismic data. The cable may thus be non-conducting and need not contain any external electrical wiring. The cable may e.g. be a rope or a wire. In the following description the invention is explained with reference to a cable, but a rope or a wire may also be

25 used. The seismic nodes may be attached in any position along the cable by a snap-on mechanism. The snap-on mechanism may also function as a snap-off mechanism when removing the seismic nodes from the cable.

30 Figure 1a illustrates in top view an attachment device 2 for attaching a seismic node 20 from Figure 1 to the cable 1. The attachment device 2 firmly attaches the seismic node 20 to the cable and avoids in-line sliding along the cable without use of connection points along the cable. The attachment device 2 is arranged on an

upper side of the seismic node. The attachment device 2 comprises an in-line fastening device 6 fastening the in-line fastening device to the cable 1, and two locking devices 3 securing the cable 1 in the at least one in-line fastening device 6. The in-line fastening device 6 fastens the cable 1 in-line. The two locking devices 3 prevent the cable from escaping from the fastening device 6. The cable is fastened in the in-line fastening device by in-line forces from the cable. In Figure 1a, a locking device 3 is arranged on opposite sides of the in-line fastening device 6. This arrangement secures the seismic node to the cable preventing the cable from slipping out of the in-line fastening device. The locking devices 3 have a design ensuring the locking devices to be pushed, by own force, back to its normal position (normal position illustrated in Figure 3b). This function may be accomplished by providing the locking devices with a resilient member. The resilient member may function as a biased hinge 10. The hinge function may also be accomplished by using a biased bolt. The locking devices 3 may also be arranged so as to guide the cable into engagement with the in-line fastening device.

The in-line fastening device 6 provides increased fastening of the cable 1 as the in-line forces from the cable increases. The in-line forces may be due to tensile forces along the cable during deployment, retrieval or when arranged on the sea bottom. The in-line fastening device 6 provides increased fastening for forces acting in any longitudinal direction; i.e. for in-line forces having a direction along the cable both in a forward and backward longitudinal direction seen in relation to the travelling direction of the cable. The in-line fastening device 6 may comprise a first in-line fastening device providing increased fastening of the cable as the in-line force from the cable increases in a forward longitudinal direction, and a second in-line fastening device providing increased fastening of the cable as the in-line force from the cable increases in a rearward longitudinal direction. In Figure 1a the fastening device 6 is arranged in a longitudinal direction parallel with the cable, and the locking devices 3 in a lateral direction in view of the cable, but other arrangements may also be possible. Also, further fastening devices 6 may be used depending on the size of the seismic node. The fastening devices may be arranged side by side. A locking device 3 may also be arranged between the fastening devices 6, and not only at the ends of the fastening device 6 as

illustrated in Figure 1b, providing increased securing of the cable in the in-line fastening device. The in-line fastening devices 6 and the locking devices 3 may be passive; i.e. their function may only depend on the forces resulting from the cable itself during deployment, retrieval and when placed on the sea bottom.

5 In use the cable may have lengths of several kilometers, and there will be a large number of seismic nodes attached to the cable. The cable should endure tensile stress resulting from a weight in the order of 10 tons at each end of the cable. The locking device 3 should also have some flexibility in order to absorb forces in the lateral direction from the cable without breaking.

10

In Figure 1a a top part 5 of the attachment device 2 is illustrated as transparent for illustration purposes only, in order to better illustrate the principle of the in-line fastening device 6 and locking devices 3. The top part 5 is provided with openings 4 in order for the locking devices 3 to be able to move through the top part 5 when
15 attaching and detaching the seismic node from the cable. The attachment device 2 may further comprise a back wall 7. The back wall 7 together with the top part 5 and locking devices 3 secure the cable from escaping in any other direction than through an opening 8 (shown in Figure 3a). The in-line fastening device 6 and the
20 locking devices 3 may be provided in a housing with an opening 8 for receiving the cable. The back wall 7, top part 5 and either a bottom part of the attachment device 2 or an end face of the seismic node on which the attachment device is arranged, may form the housing. The housing may have a U-shape or horse shoe like shape.

25 Figure 1b schematically illustrates in top view internal details of an embodiment of the in-line fastening device 6 of the attachment device from Figure 1a. In Figure 1b the in-line fastening device 6 comprises oppositely arranged sloping ridges 6 for firmly fastening the cable. A first group of ridges (to the left) and a second group of ridges (to the right) are arranged at different sloping angles in order to fasten the
30 cable due to forces acting in both longitudinal directions. The first group of ridges securely fastens the cable when the in-line force from the cable acts to the left, whereas the second group of ridges securely fastens the cable when the in-line force from the cable acts to the right in Figure 1b. As can be seen in the detailed

view of a cross section of the ridges, the ridges are arranged on interior surfaces of a slot forming a valley with decreasing cross-section. The sloping arrangement of the ridges together with the valley cross-section provides increased fastening of the cable as the in-line forces along the cable increases. The opening of the slot
5 faces the opening 8. Examples of in-line fastening devices using ridges may e.g. be a cleat type, a camcleat type with rotation wheels, a camcleat type without rotation wheels, a jamming cleat type or a valley cleat type device. The in-line locking device 6 is not limited to a ridge type device, but may be any kind of in-line fastening mechanism fastening the cable due to the in-line force by the cable.

10

A seismic node 20 with an attachment mechanism from Figure 1a is schematically illustrated in Figure 2 in side view. The locking device 3 is seen in a locked position securing the cable 1. In the locked position, the locking device prevents the cable from escaping from the in-line fastening device 6. The ridges in the in-line locking device 6 are also seen schematically illustrated above and under the
15 cable 1. The in-line locking device 6 is in the embodiment in Figure 2 also provided behind (not shown) the cable. Figure 2 shows the top part 5 with openings 4 above the in-line locking device 6 with the cable 1 firmly fastened. The attachment device 2 may be an integrated part of the seismic node or produced as a separate part for later attachment to the seismic node. All the parts of the attachment device may
20 be produced in a plastic material, thus avoiding use of metal.

Figure 3a is a schematic illustration in front view of the seismic node with an attachment device 2 from Figure 2 provided on an upper side of the seismic node
25 20. The locking device 3 is seen in a locked position. The top part 5 is seen partly transparent to illustrate the shape of the locking device. The locking device 3 blocks the opening 8 for the cable and the top part 5 prevents upward movement of the cable 1. The locking device 3 is in the embodiment in Figure 3a provided with a resilient member 10 attached to the top part 5. The resilient member 10 is
30 biased in order to secure the locking device 3 in the locked position. The locked position is the normal position of the resilient member 10. The resilient member may also be attached to a lower part of the housing of the attachment device. The resilient member may be in the form of a hinge member. The locking device 3 is

arranged to be pushed open upon engagement with the cable, for thereby returning to a locking position securing the cable. The locking device 3 is designed to enable the cable to come into contact with the in-line fastening device 6 when attaching the seismic node to the cable. However, after engagement, when the seismic nodes are attached to the cable, the locking device is arranged so as not to open when the cable exerts forces in a direction out of the opening 8 of the locking device.

In Figure 3a, the in-line fastening device 6 and the locking device 3 are arranged on an upper side of the seismic node 20. When the seismic nodes are deployed on the ocean bottom, this arrangement ensures that the front side of each seismic node is facing down, ensuring seismic coupling to the sea bottom. If a seismic node is standing on a narrow side on the sea bottom, seismic sensing may not be possible at all or at least the seismic signals may be poorly detected by the sensors in the seismic node. The in-line fastening device 6 and the locking device 3 are also mutually arranged so as to ensure the cable is in a non-centered position on the narrow side of the seismic node. This avoids spinning/twirling of the seismic nodes around the cable during deployment or retrieval due to ocean currents, tidal currents or the movements by the vessel.

The cable is deployed into the sea and the seismic nodes 20 attached during deployment in positions along the cable. The cable is not provided with connection points as in the prior art solutions. The seismic nodes 20 may thus be attached in any position along the cable. These positions may be controlled by a computer. The positions may be predetermined. When attaching and detaching a seismic node to the cable, the cable and the seismic node locking devices are guided towards each other. This may be done in a number of alternative ways. The cable may be guided towards the locking device of the seismic node. Alternatively, the seismic node locking device may be guided towards the cable. In a further alternative, both the cable and the seismic node locking device may be guided towards each other. A guiding tool may be used for bringing the cable and the seismic node locking device towards each other.

Figure 3b illustrates the locking device 3 in a normal (locking) position. Figure 3c illustrate how the locking device 3 may be pushed open from the locked position by a guiding tool 11 when detaching the seismic node from the cable. The cable 1 is applying a light pressure towards the locking device 3, while the guiding tool 11 is moved in through the gap 8 and in the end pushing the locking device 3 to an open position as shown in Figure 3c. When the locking device 3 is open, the cable move by its own force out passed the locking device 3 until the cable stops at the guiding tool 11. The cable then follows the guiding tool 11 out of the opening 8 until the cable is free from the attachment device 2. When attaching the seismic nodes to the cable for deployment into the sea, the locking device 3 is pushed open to let the cable 1 pass the locking device 3. The locking device 3 returns to the locking position avoiding the cable 1 from escaping through gap 8. The cable is further guided into the in-line locking device 6. This may be accomplished by using the guiding tool 11, or by using the movement of the cable 1 in the forward longitudinal direction. Movement between the seismic node and the cable in a longitudinal direction results in firmly fastening of the cable in the in-line fastening device 6. During deployment and retrieval the seismic nodes may be attached to / detached from the cable at the same speed as the deployment/retrieval of the cable.

20

Having described preferred embodiments of the invention it will be apparent to those skilled in the art that other embodiments incorporating the concepts may be used. These and other examples of the invention illustrated above are intended by way of example only and the actual scope of the invention is to be determined from the following claims.

25

CLAIMS

1. An attachment device (2) for attaching a seismic node (20) to a cable (1) comprising:
 - 5 - at least one in-line fastening device (6) for fastening the at least one in-line fastening device to the cable (1), wherein the at least one in-line fastening device (6) is adapted to provide fastening by an in-line force of the cable (1); and
 - at least one locking device (3) securing the cable (1) in the at least one in-line fastening device (6).
- 10 2. An attachment device (2) according to claim 1 , further comprising at least two locking devices (3), wherein a locking device (3) is arranged on opposite sides of the at least one in-line fastening device (6).
- 15 3. An attachment device (2) according to claim 1 or claim 2, wherein the at least one in-line fastening device (6) is adapted to provide increased fastening of the cable as the in-line forces from the cable increases.
4. An attachment device (2) according to one of claims 1-3, wherein the at
20 least one in-line fastening device (6) comprising a number of oppositely arranged ridges for fastening of the in-line fastening (6) device to the cable (1).
5. An attachment device (2) according to one of claims 1-4, comprising a
25 housing having an opening (8) at one end for receiving the cable (1), wherein the at least one in-line fastening (6) device is arranged inside the housing facing the opening (8).
6. An attachment device (2) according to one of claims 1-5, wherein the at
30 least one locking device (3) is adapted to be pushed open upon engagement with the cable, for thereby returning to a locking position securing the cable.

7. An attachment device (2) according to one of claims 1-6, wherein the locking device (3) comprising a biased resilient member for returning the locking device to a locking position.
- 5 8. An attachment device (2) according to one of claims 5-7, wherein the housing further comprising a back wall (7) and a top part (5).
9. An attachment device (2) according to one of claims 1-8, wherein the at least one in-line fastening device (6) and the at least one locking device (3) are
10 passive devices.
10. An attachment device (2) according to one of claims 1-9, wherein the cable is a rope or a wire.
- 15 11. A seismic node (20) comprising a device (2) for attaching the seismic node to a cable (1) according to at least one of claims 1-10.
12. A seismic node (20) according to claim 11, wherein the attachment device is arranged on an upper side of the seismic node (20) ensuring a front side of the
20 seismic node is facing down on the ocean bottom.
13. A seismic node (20) according to claim 10, wherein the cable is arranged in a non-centered position in the attachment device (2).
- 25 14. A method for deploying a number of seismic nodes according to one of claims 11-13 into the sea, the method comprising:
- deploying a cable into the sea,
 - attaching the seismic nodes to the cable during deployment, wherein each seismic node is attached to the cable by the following method:
30
 - pushing the at least one locking device to an open position;
 - inserting the cable passed the at least one locking device, whereby the at least one locking device returns to a locking position, and

- fastening the cable to the at least one in-line fastening device by the cable movement in a longitudinal direction of the cable.

15. Method according to claim 14, further comprising using a guiding tool for
5 bringing the cable and the at least one seismic node locking device towards each other before pushing the at least one locking device to an open position.

16. A method for retrieving a number of seismic nodes according to one of claims 11-13 attached to a cable from the sea, the method comprising:

10 - retrieving the cable,

- detaching each of the seismic nodes from the cable during retrieval by:

- pushing the at least one locking device to an open position;

- moving the cable outwards passed the at least one locking device,

whereby the at least one locking device returns to its closed position, and

15 - whereby the movement of the cable releasing the cable from the at least one in-line fastening device of the seismic node.

17. Method according to one of claims 14-16, further comprising using a guiding
20 tool for pushing the at least one locking device to an open position.

18. Method according to one of claims 14-17, wherein the cable is a rope or a
wire.

19. Method according to one of claims 14-17, wherein the guiding tool is in the
25 form of a guiding wheel guiding the cable during deployment and retrieval of the cable.

Fig.1

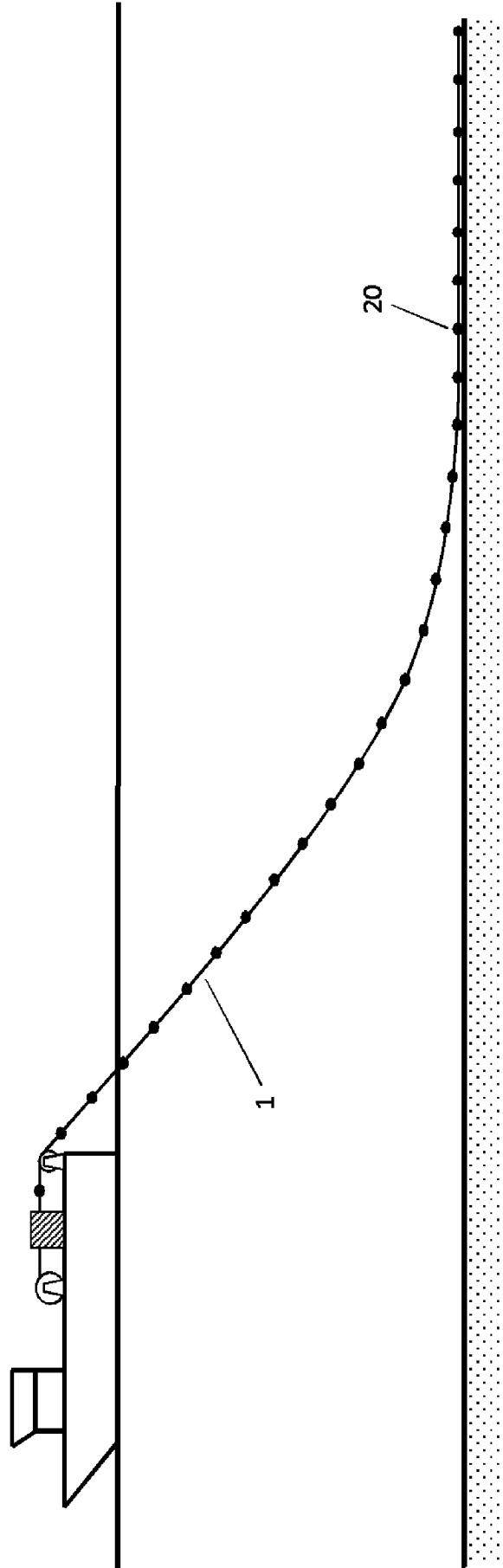

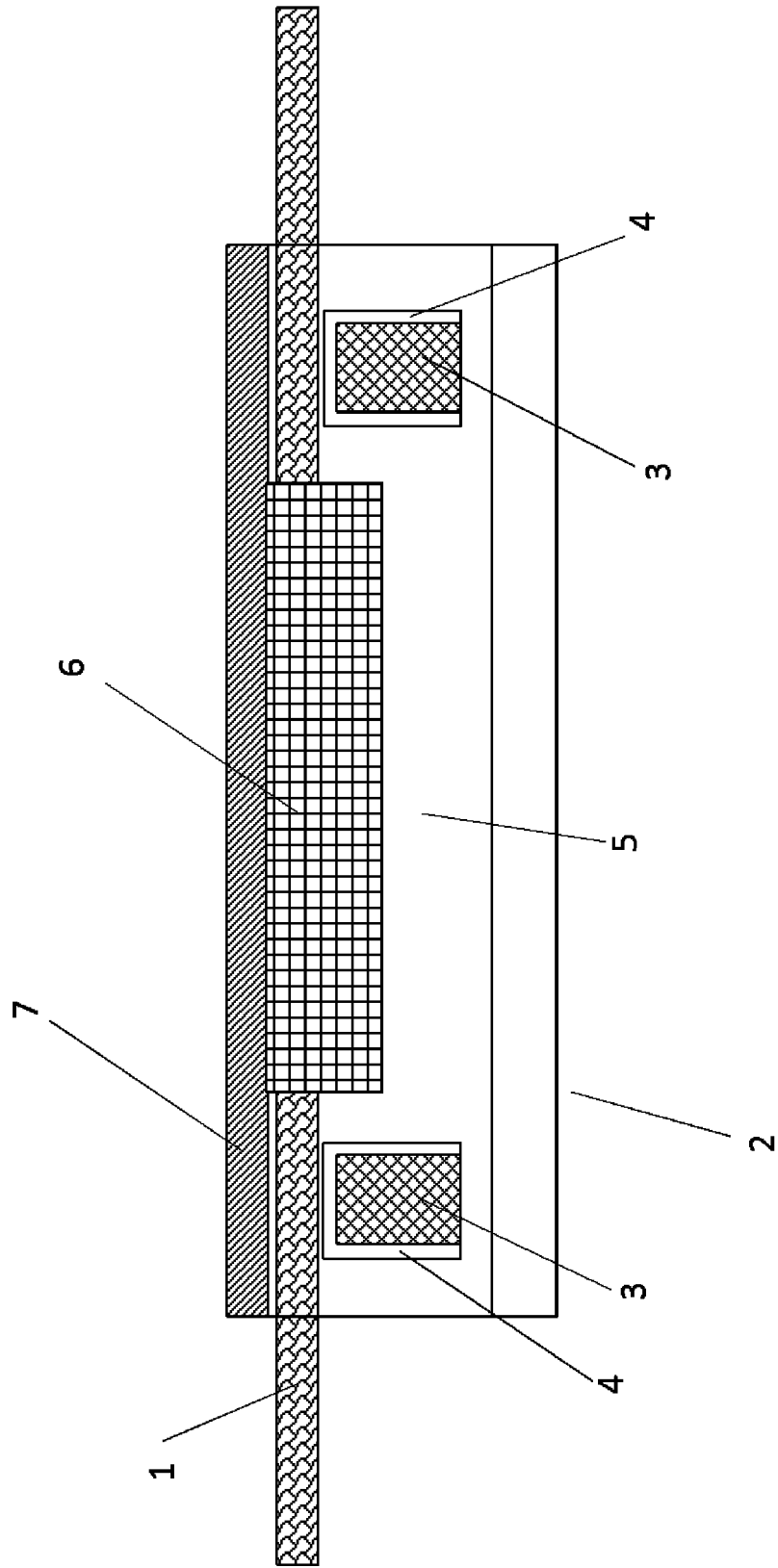

Fig. 1a

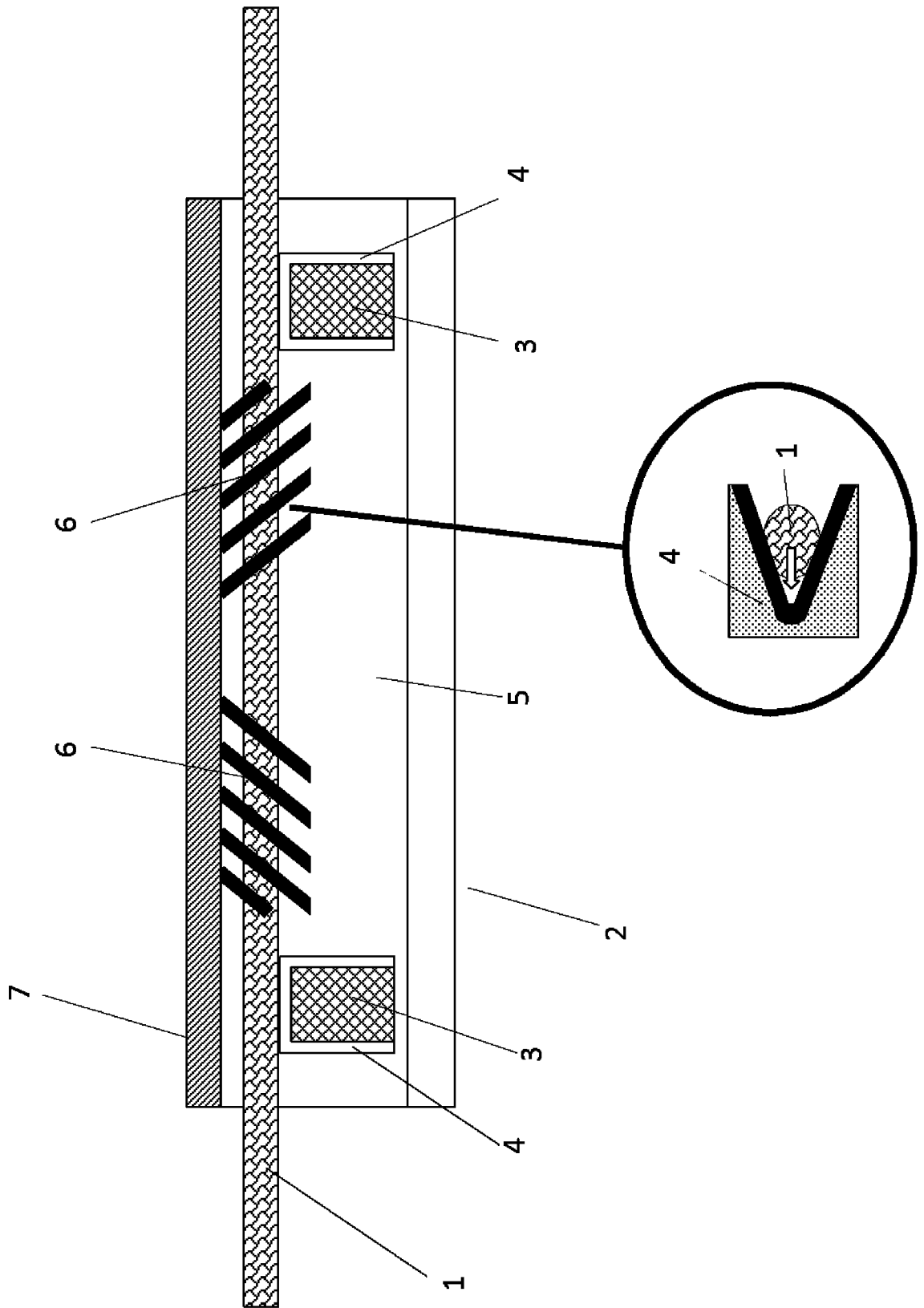
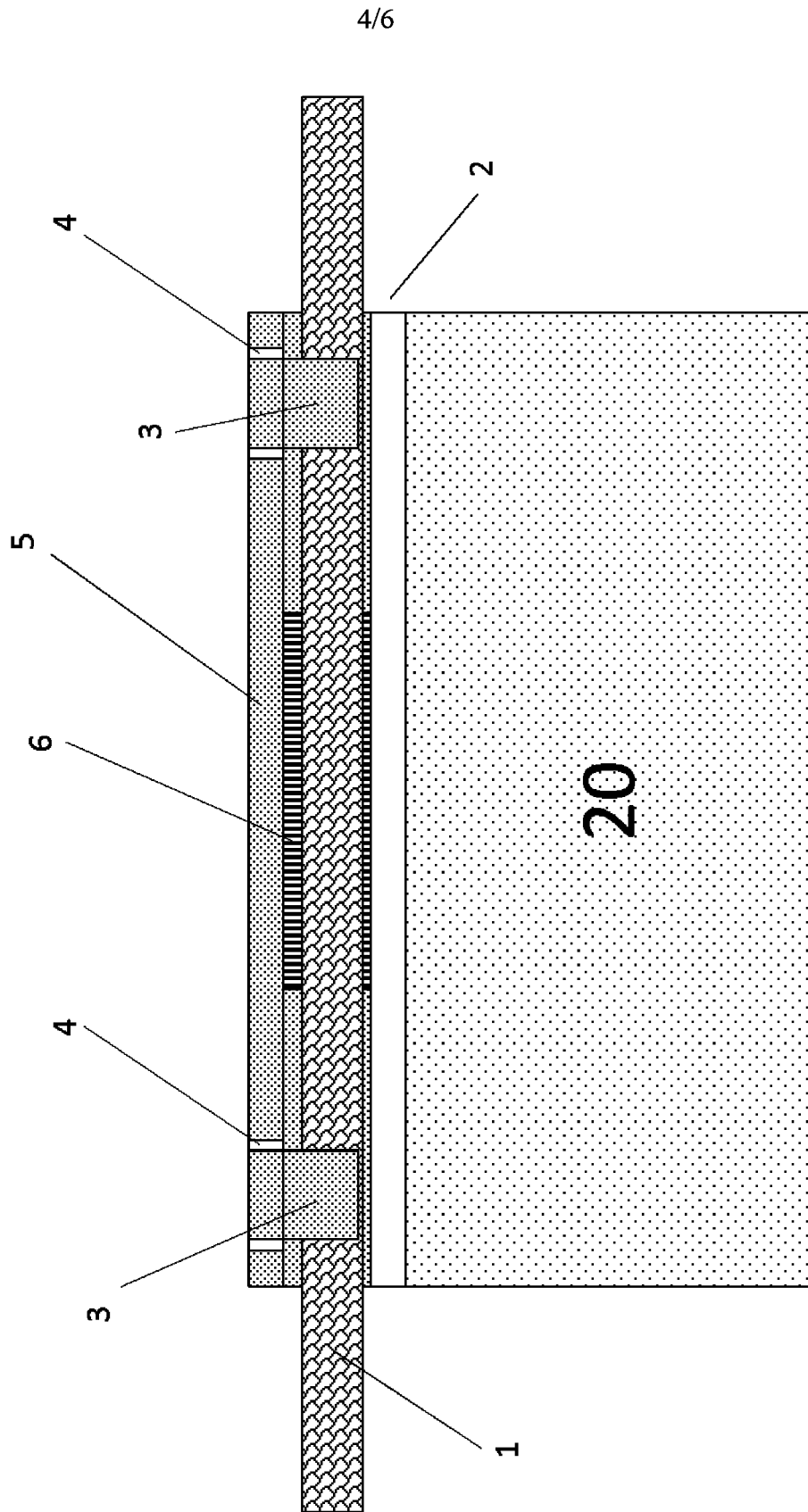

Fig. 1b

Fig. 2



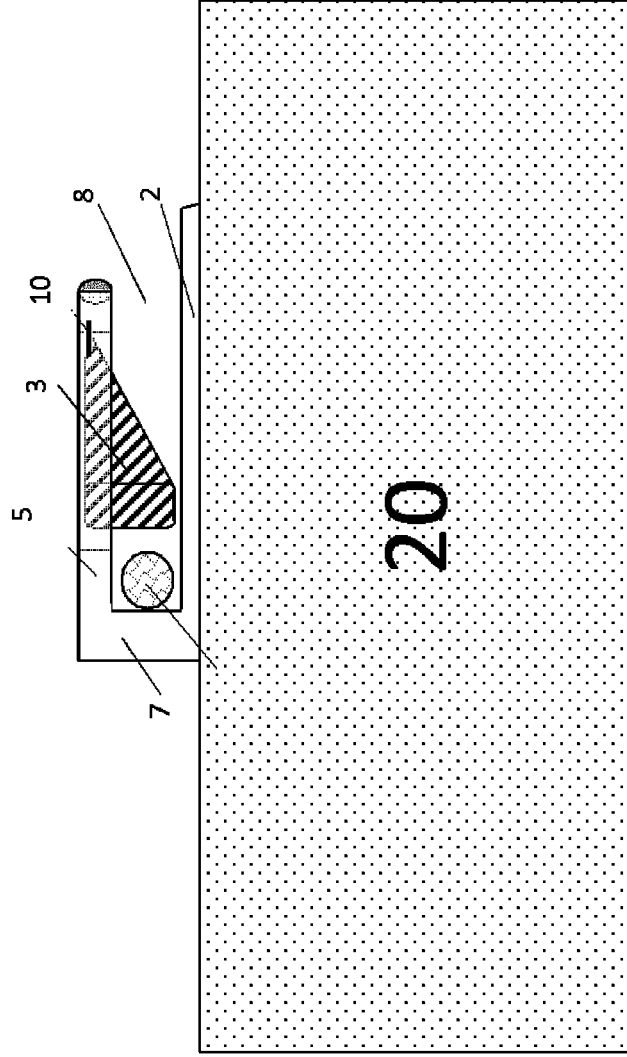

Fig. 3a

Fig. 3b

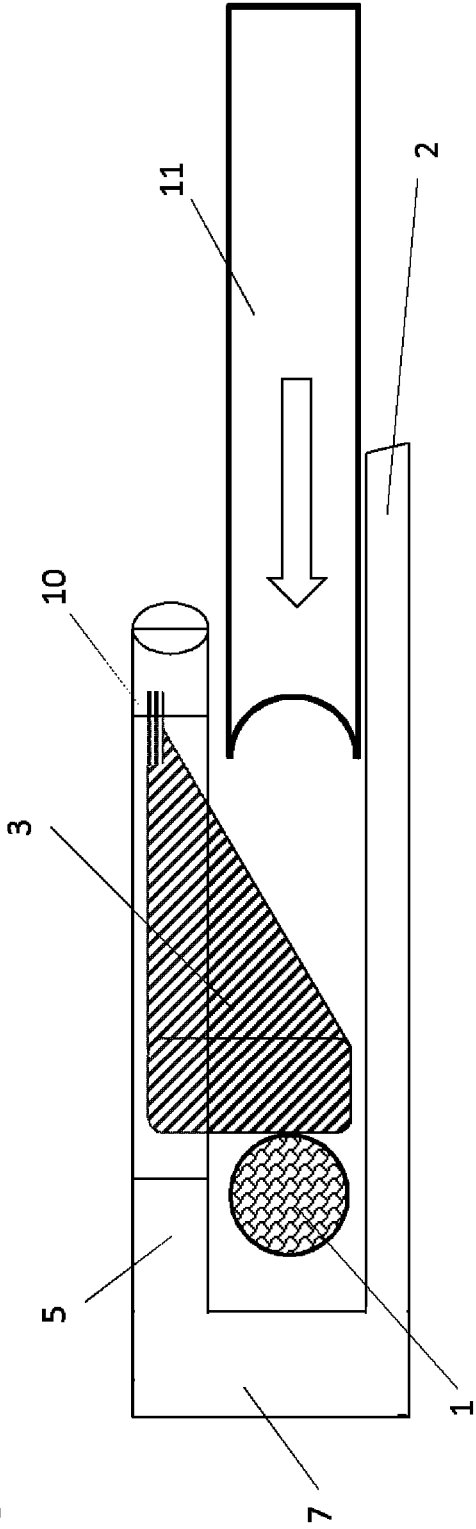

Fig. 3c

