

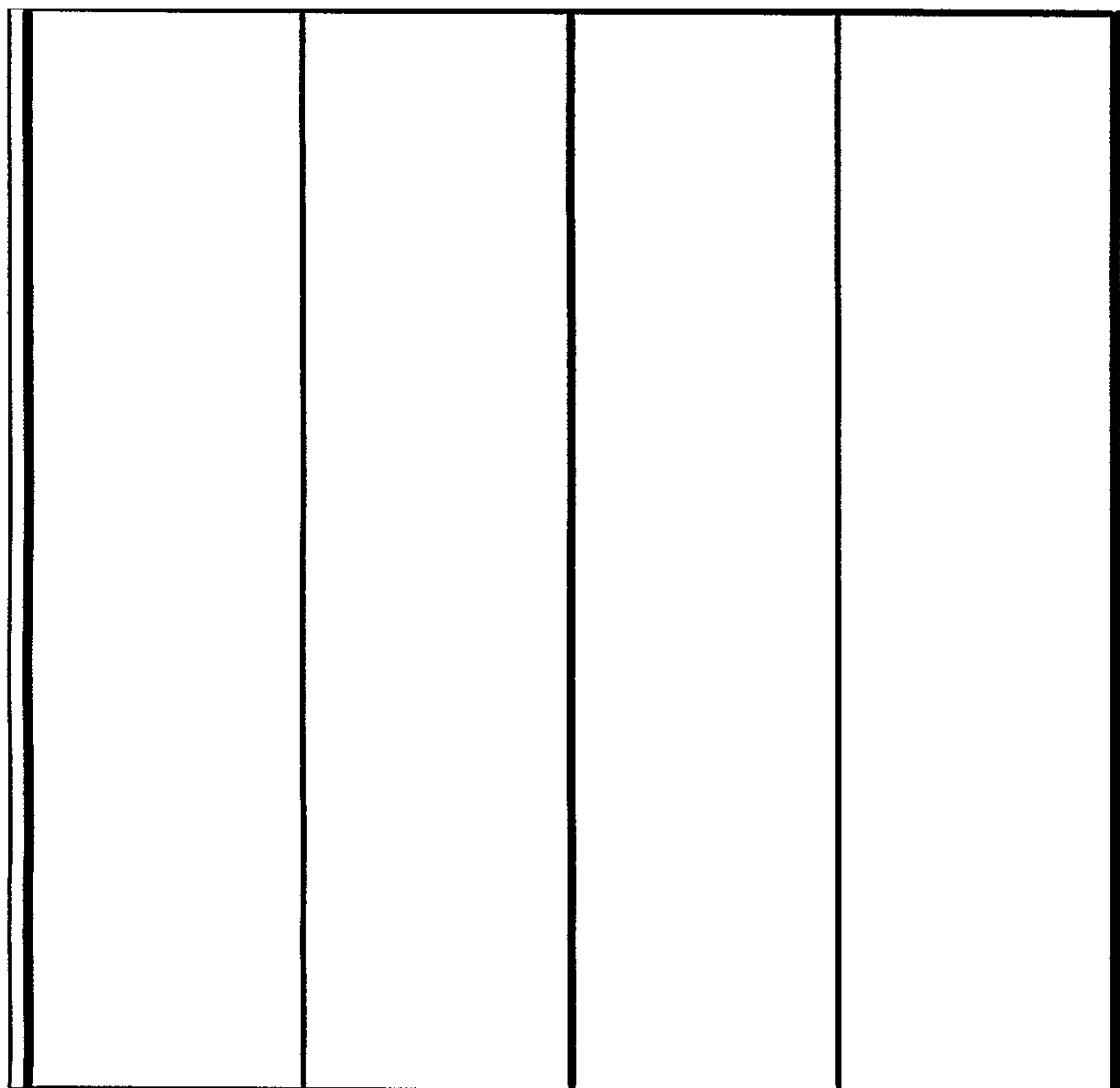

(86) Date de dépôt PCT/PCT Filing Date: 2005/11/25
 (87) Date publication PCT/PCT Publication Date: 2006/06/01
 (85) Entrée phase nationale/National Entry: 2007/04/13
 (86) N° demande PCT/PCT Application No.: CH 2005/000698
 (87) N° publication PCT/PCT Publication No.: 2006/056095
 (30) Priorité/Priority: 2004/11/26 (CH1950/04)

(51) Cl.Int./Int.Cl. *F24F 13/068* (2006.01),
F24F 11/00 (2006.01), *F24F 3/16* (2006.01)
 (71) Demandeur/Applicant:
 LK LUFTQUALITAET AG, CH
 (72) Inventeur/Inventor:
 FLEISCHER, WERNER, CH
 (74) Agent: ROBIC

(54) Titre : ELEMENT PLAT POUR TEMPERER L'AIR AMBIANT
 (54) Title: FLAT ELEMENT FOR THERMALLY ADJUSTING INDOOR AIR



(57) **Abrégé/Abstract:**

The invention relates to a flat element (1) for thermally adjusting indoor air, especially for cooling indoor air. Said flat element (1) comprises an air guiding chamber (2) and an active cover surface (3) having microholes (4). The air guiding chamber (2) has an upper side (5), a plurality of sidewalls (6a, 6b), at least one opening (7) for letting air in and at least one opening (8) for discharging air. The active cover surface (3) closes the air guiding chamber (2) towards its open bottom side. The upper side (5) of the air guiding chamber (2) is shaped so as to have at least one baffle (10) having at least one air guiding edge (11).



2584 260

(12) NACH DEM VERTRAG ÜBER DIE INTERNATIONALE ZUSAMMENARBEIT AUF DEM GEBIET DES PATENTWESENS (PCT) VERÖFFENTLICHTE INTERNATIONALE ANMELDUNG

(19) Weltorganisation für geistiges Eigentum
Internationales Büro



(43) Internationales Veröffentlichungsdatum
1. Juni 2006 (01.06.2006)

PCT

(10) Internationale Veröffentlichungsnummer
WO 2006/056095 A1

(51) Internationale Patentklassifikation:
F24F 13/068 (2006.01) F24F 11/00 (2006.01)
F24F 3/16 (2006.01)

(74) Anwalt: ZINK, Markus, Peter; Patentanwaltsbüro Zink,
Hochfelderstrasse 17 b, CH-8173 Neerach (CH).

(21) Internationales Aktenzeichen: PCT/CH2005/000698

(81) Bestimmungsstaaten (soweit nicht anders angegeben, für jede verfügbare nationale Schutzrechtsart): AE, AG, AL, AM, AT, AU, AZ, BA, BB, BG, BR, BW, BY, BZ, CA, CH, CN, CO, CR, CU, CZ, DE, DK, DM, DZ, EC, EE, EG, ES, FI, GB, GD, GE, GH, GM, HR, HU, ID, IL, IN, IS, JP, KE, KG, KM, KN, KP, KR, KZ, LC, LK, LR, LS, LT, LU, LV, LY, MA, MD, MG, MK, MN, MW, MX, MZ, NA, NG, NI, NO, NZ, OM, PG, PH, PL, PT, RO, RU, SC, SD, SE, SG, SK, SL, SM, SY, TJ, TM, TN, TR, TT, TZ, UA, UG, US, UZ, VC, VN, YU, ZA, ZM, ZW.

(22) Internationales Anmeldedatum:
25. November 2005 (25.11.2005)

(25) Einreichungssprache: Deutsch

(26) Veröffentlichungssprache: Deutsch

(30) Angaben zur Priorität:
1950/04 26. November 2004 (26.11.2004) CH

(71) Anmelder (für alle Bestimmungsstaaten mit Ausnahme von US): LK LUFTQUALITÄT AG [CH/CH]; Staldenhof 3A, CH-6014 Littau (CH).

(84) Bestimmungsstaaten (soweit nicht anders angegeben, für jede verfügbare regionale Schutzrechtsart): ARIPO (BW, GH, GM, KE, LS, MW, MZ, NA, SD, SL, SZ, TZ, UG, ZM, ZW), eurasisches (AM, AZ, BY, KG, KZ, MD, RU, TJ, TM), europäisches (AT, BE, BG, CH, CY, CZ, DE, DK, EE, ES, FI, FR, GB, GR, HU, IE, IS, IT, LT, LU, LV, MC,

(72) Erfinder; und

(75) Erfinder/Anmelder (nur für US): FLEISCHER, Werner [DE/CH]; Sonnenrain 58, CH-6103 Schwarzenberg (CH).

[Fortsetzung auf der nächsten Seite]

(54) Title: FLAT ELEMENT FOR THERMALLY ADJUSTING INDOOR AIR

(54) Bezeichnung: FLÄCHENELEMENT ZUR TEMPERIERUNG VON RAUMLUFT

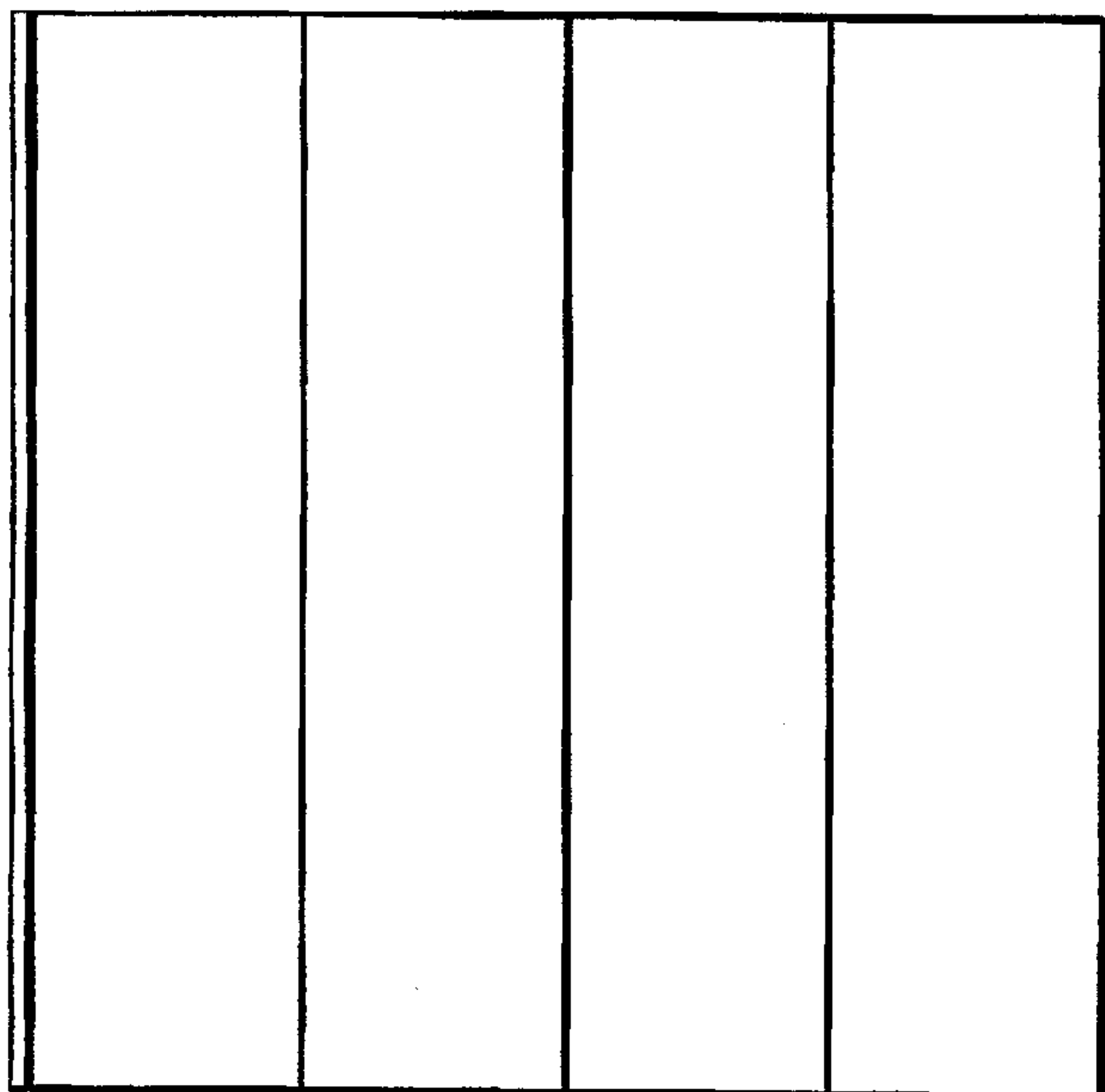

(57) Abstract: The invention relates to a flat element (1) for thermally adjusting indoor air, especially for cooling indoor air. Said flat element (1) comprises an air guiding chamber (2) and an active cover surface (3) having microholes (4). The air guiding chamber (2) has an upper side (5), a plurality of sidewalls (6a, 6b), at least one opening (7) for letting air in and at least one opening (8) for discharging air. The active cover surface (3) closes the air guiding chamber (2) towards its open bottom side. The upper side (5) of the air guiding chamber (2) is shaped so as to have at least one baffle (10) having at least one air guiding edge (11).

[Fortsetzung auf der nächsten Seite]

WO 2006/056095 A1

WO 2006/056095 A1

NL, PL, PT, RO, SE, SI, SK, TR), OAPI (BF, BJ, CF, CG, CI, CM, GA, GN, GQ, GW, ML, MR, NE, SN, TD, TG).

Veröffentlicht:

— mit internationalem Recherchenbericht

Zur Erklärung der Zweibuchstaben-Codes und der anderen Abkürzungen wird auf die Erklärungen ("Guidance Notes on Codes and Abbreviations") am Anfang jeder regulären Ausgabe der PCT-Gazette verwiesen.

(57) Zusammenfassung: Die vorliegende Erfindung betrifft ein Flächenelement ein Flächenelement (1) zur Temperierung von Raumluft, insbesondere zur Kühlung von Raumluft. Das Flächenelement (1) umfasst eine Luftführungskammer (2) und eine aktive Deckenfläche (3) mit Mikrolöchern (4). Die Luftführungskammer (2) weist eine Oberseite (5), mehrere Seitenwände (6a, 6b) wenigstens eine Öffnung (7) für den Einlass von Luft und wenigstens eine Öffnung (8) für den Auslass von Luft auf. Die aktive Deckenfläche (3) schliesst die Luftführungskammer (2) auf ihrer offenen Unterseite ab. Die Oberseite (5) der Luftführungskammer (2) ist derart geformt, dass sie wenigstens eine Schikane (10) mit wenigstens einer Luftleitkante (11) aufweist.

FLAT ELEMENT FOR THERMALLY ADJUSTING INDOOR AIR

The present invention is directed to a flat element for thermal adjustment of indoor air and to a device for thermal adjustment of indoor air.

5 The thermal adjustment of indoor air may be realized by means of air convection. Thereby exist the most various elements for the outlet of air, for example twist outlets that are mounted on a ceiling.

10 A further alternative for the thermal adjustment of indoor air consists in the utilization of ceiling areas that are cooled with water. Due to the possibility of the condensation of water vapor on these with water cooled surfaces an aeration by means of windows aeration is excluded. This means that such with water
15 cooled surfaces must be combined with a separate, central fresh air supply.

 A further alternative for the thermal adjustment of indoor air comprises the thermal area-adjustment by means of concrete core cooling. This kind of thermal
20 adjustment of indoor air is very slow.

 In EP 1 078 205 B1 are described air-cooling elements that have micro-holes in the cooling wall. These micro-holes have a diameter of not more than 0.8 mm. The free cross-section in this cooling wall is not
25 more than 2%, referred to the total area of the cooling wall.

 For the generation of turbulences in the fresh air must be present an antechamber. Such antechambers have economical and technical drawbacks. A technical

drawback consists therein that into the antechamber must be mounted outlet ports or holes through which the fresh air must be blown onto the cooling wall.

5 This in turn means that directed air streams are generated. Thereby result cooling areas with different activities.

These air-cooling elements comprise a lot and constructive complex single components and are thus correspondingly expensive.

10 It is an object of the present invention to provide a flat element for thermal adjustment of indoor air, especially for cooling of indoor air, for example in the form of a ceiling element or in the form of a wall element.

15 With this flat element the fresh air shall be brought into a room spread over a relative capacious area in a comfortable and pleasant, especially draft-free, dynamic adaptable and essentially noiseless way.

20 This flat element shall be operated only by one single medium, namely air.

25 With this flat element shall be made possible simultaneously a uniform thermal adjustment of the area (use of the thermal radiation) and a supply of the room with the necessary amount of fresh air (use of the thermal convection).

With this flat element it shall be possible to produce an essentially laminar displacement air stream.

With this flat element the discharge effect of the preferably ionized supply air shall be minimized, that is, that this flat element shall not comprise parts that enhance the discharge effect excessively.

5 With this flat element the preferably ionized supply air shall act optimally in the room to be thermally adjusted.

10 It is a further object of the present invention to provide a flat element for thermal adjustment of indoor air, especially for cooling of indoor air, for example in the form of a ceiling element or in the form of a wall element, with which in special rooms with a highly required clean room characteristic particles may be pushed away from the technological caused active
15 area.

 It is a further object of the present invention to provide such a flat element with which the formation of a condensate of water vapor at the essential surfaces of this flat element may be avoided.

20 It is a further object of the present invention to provide such a flat element with which a high heat transport in the room to be thermally adjusted is possible.

25 This flat element shall comprise preferably only a few and constructive simple single parts.

 This flat element shall require preferably only a small installation height in order that the effective height of the room may be used optimally.

With the present invention these objects are attained.

The inventive flat element 1 - also named room element - for thermal adjustment of indoor air, especially for cooling of indoor air, for example in the form of a ceiling element or in the form of a wall element, whereby the form of a ceiling element is preferred,

is characterized in that

10 it comprises an air conduct chamber 2 and an active ceiling area 3 with micro-holes 4, whereby

- the air conduct chamber 2 has

-- an upper surface 5,

-- several side walls 6a, 6b,

15 -- at least one opening 7 for the inlet of air,

-- at least one opening 8 for the outlet of air,

20 whereby into each opening 7 for the inlet of air and into each opening 8 for the outlet of air is inserted a connecting piece 9 in the form of a pipe and is essentially hermetically sealed, and

whereby the air conduct chamber 2 is open on its bottom side,

- the active ceiling area 3 terminates the air conduct chamber 2 on its open bottom side,

- the air conduct chamber 2 and the active ceiling area 3 are essentially hermetically sealed with each other,

- upper surface 5 of the air conduct chamber 2 is formed in such a way that it has at least one baffle 10 with at least one air conduct angle 11, whereby

-- this (these) baffle(s) 10 point(s) to the side of the active ceiling area 3, which is aligned to the inside of the flat element 1,

-- this (these) baffle(s) 10 generate(s) turbulences in an supplied air stream, and

-- this (these) baffle(s) 10 is (are) arranged crosswise to the connecting line between the opening(s) 7 for the inlet of air and the opening(s) 8 for the outlet of air, and

- the opening(s) 7 for the inlet of air and the opening(s) 8 for the outlet of air are arranged in opposite side walls 6a.

The inventive device for thermal adjustment of indoor air, especially for cooling of indoor air, is characterized in that it comprises at least one column of inventive flat elements 1a,1b,1c, that are essentially hermetically sealed with each other.

Preferred embodiments of this invention are defined in the dependent claims.

In the following part are described possible embodiments of the present invention.

Thereby is made also reference to the figures.

Figure 1 shows purely schematically transverse
5 from the top toward a possible upper surface 5 of an air
conduct chamber 2.

Figure 2 shows a side view of the upper sur-
face 5 of the air conduct chamber 2 as shown in Figure
1.

10 Figure 3 shows a top view on the upper surface
5 of the air conduct chamber 2 as shown in Figure 1.

Figure 4 shows purely schematically the un-
rolling of the upper surface 5 of the air conduct cham-
ber 2 made of one piece, as shown in Figure 1. In this
15 Figure the interrupted lines mean edges downwards, and
the drawn through lines mean edges upwards.

Figure 5 shows purely schematically the un-
rolling of the active ceiling area 3 with micro-holes 4
made of one piece. In this Figure the interrupted lines
20 mean edges downwards. The micro-holes 4 are shown only
suggestively in all four corners.

Figure 6 shows purely schematically a perspec-
tive view of the inner side of the active ceiling area 3
which unrolling is shown in Figure 5.

25 Figure 7a shows purely schematically trans-
verse from the top toward a possible side wall 6b for an
air conduct chamber 2.

Figure 7b shows purely schematically transverse from the top toward a possible side wall 6b with cut-outs for an air conduct chamber 2.

5 Figure 8 shows purely schematically transverse from the top toward a possible air conduct chamber 2 with mounted side walls 6b and connecting pieces 9 in the form of pipes.

Figure 9 shows a side view of the air conduct chamber 2 as shown in Figure 8.

10 Figure 10 shows a top view on the air conduct chamber 2 as shown in Figure 8.

Figures 11a to 11d show various views of a suitable bracket 30 for the hanging of an air conduct chamber 2.

15 Figure 12 shows the cross section through a suitable ceiling grid profile 25 to which are mounted a bracket 30, an air conduct chamber 2 and an active ceiling area 3.

20 Figure 13 shows a top view on a possible device for thermal adjustment of indoor air. This device comprises two columns of each three flat elements 1a, 1b, 1c.

Figure 14 shows a side view of the device for thermal adjustment of indoor air as shown in Figure 13.

25 Figure 15 shows in a non limiting manner cross sections and alignments through possible forms of baffles 10.

Figure 16 shows purely schematically a possible scheme according to which, based on the actual situation, an ionization of the supply air may be guaranteed.

5 Figure 17 shows purely schematically a possible manner of an alignment of a separately hung up foil 26 and of a light source 28.

An air conduct chamber 2 was prepared as follows:

10 For the preparation of the upper surface 5 of an air conduct chamber 2 was used a 0.75 mm thick electrolytically zinc-plated steel plate that had a length of 960 mm and a width of 577 mm.

15 In both front sides 6a was punched an opening 7 for the inlet of air and an opening 8 for the outlet of air. Both openings 7,8 had a diameter of 83 mm.

On both longitudinal sides were mounted holes 20 that served for the fixation of the side walls 6b.

20 On both longitudinal sides and on both front sides 6a were mounted free press cuts 19 and edges 18 with an angle of 90° downwards.

25 In a distance of 118 mm, 301 mm and 480 mm from the front side 6a with the opening 8 for the outlet of air and in a distance of 118 mm and 301 mm from the front side 6a with the opening 7 for the inlet of air were mounted at the respective locations edges with the angles α , β , γ and δ in an alternative way upwards and downwards.

The angle α had a value of 103° , and the angle β had a value of 102° . The angles γ and δ had the same size and had each a value of 52° .

The so prepared upper surface 5 of the air
5 conduct chamber 2 had two baffles 10 with each a triangular cross section. The height h of these two baffles 10 was 113 mm.

The length of the upper surface 5 of this air
10 conduct chamber 2 was 590 mm, and the width of the upper surface 5 of this air conduct chamber 2 was 560 mm.

There were prepared two side walls 6b from a
1 mm thick electrolytically zinc-plated steel plate.
These side walls 6b had a length of 590 mm and a height
of 112 mm and were edged along one longitudinal side for
15 10 mm for an angle of 90° . This edge served as a stopper for a bracket 30.

These side walls 6b had holes 21 that were adjusted to the holes 20 in the longitudinal side of the upper surface 5 of the air conduct chamber 2.

20 Both side walls 6b were connected with the upper surface 5 of the air conduct chamber 2 by means of rivets ("Popnieten") in an essentially hermetically way.

These side walls 6b serve also for the stabilization of the upper surface 5 of the air conduct chamber 2.
25

In the opening 7 for the inlet of air and in the opening 8 for the outlet of air was inserted each a connecting piece 9 in the form of a pipe.

Such a connecting piece 9 in the form of a pipe had an outer diameter of 83 mm and an inner diameter of 80 mm, a height of 28 mm and was on one side in a length of about 5 mm bended outwards in an angle of 30°, so that was formed an outer angle of 150°.

Both connecting pieces 9 in the form of pipes were each welded on at four points and were sealed in a circulating manner with silicone, so that an essentially hermetically bond was formed.

It would also be possible to prepare an air conduct chamber 2 with an injection moulding process or with a cupping process.

An active ceiling area 3 with micro-holes 4 was prepared as follows:

There was used a 0.6 mm thick electrolytically zinc-plated steel plate that had a length of 663 mm and a width of 635 mm.

In a quadratic alignment were punched along the length and along the width in a distance of each 5 mm 117 micro-holes 4 having a diameter of each 1 mm.

In the same process step were mounted at one broadside holes 31, that served as pin hole for a surface treatment, for example a powder coating.

Then were mounted at the desired locations on both longitudinal sides as well as on both broadsides free press cuts 32.

Then was effected the discharge of the plate.

On both broadsides were mounted different sized embossments 23a,23b. The small embossments 23a serve for the snap in into a ceiling grid profile 25, and the big embossments 23b serve as stopper.

5 Then were mounted the edges 33 for each an angle of 45° downwards.

 In principle it would be sufficient to have on each side one edge 33 only. But it is preferred to mount on each side two edges 33, because two edges 33 result
10 in a finally mounted flat element 1 in an optically better appearance. The distance between two edges 33 may be about 5 mm.

 For a colouring the so prepared piece was subjected to a conventional powder coating.

15 Then was fixed on the in mounted form not visible side along the edges 33 the sealing material 34. Thereby a weather strip, especially made of self-adhesive cell-caoutchouc, may be used. Especially suitable are the fire-proof polyurethane foam strips "Stop-
20 Fire" of the company Maag Technik AG in CH-8602 Dübendorf / Switzerland.

 Inventive flat elements 1 may be hung up on a sealing and may be connected with each other in the following way to an inventive device for thermal adjustment
25 of indoor air, especially for cooling of indoor air:

 A column of flat elements 1a,1b,1c may comprise from two to eight, especially from two to six, preferably from four to six, flat elements 1a,1b,1c.

On a sealing substructure are mounted suspensory mountings. In these suspensory mountings are fixed in parallel manner to each other rail-shaped ceiling grid profiles 25, especially hung up in a flexible form.

5 Ceiling grid profiles 25 that have the cross section as shown in Figure 12 are especially suitable for the purposes of the present invention.

It is preferred to use for the hanging of an air conduct chamber 2 two rail-shaped ceiling grid profiles 25 arranged in parallel manner to each other.

Then are engaged the brackets 30 as shown in Figures 11a to 11d into the two ceiling grid profiles 25.

It is preferred for the hanging of an air conduct chamber 2 on each of the two rail-shaped ceiling grid profiles 25 to engage two brackets 30.

Then a first air conduct chamber 2a is hung up at the mentioned four brackets 30.

All further air conduct chambers 2b,2c are hung up analogously.

The so hung up air conduct chambers 2a,2b,2c may be connected with each other as follows:

The connecting piece 9 in the form of a pipe that is in the opening 7 for the inlet of air in the first air conduct chamber 2a is connected with a conduct in which supply air is fed.

The connecting piece 9 in the form of a pipe that is in the opening 8 for the outlet of air in the first air conduct chamber 2a is connected with the connecting piece 9 in the form of a pipe that is in the opening 7 for the inlet of air in the second air conduct chamber 2b by means of a muffler with a centric mounted stopper and with lip seals.

Suitable mufflers for this purpose are available from the company Schmidlin AG in CH-8910 Affoltern am Albis / Switzerland.

All further air conduct chambers 2c,2d are connected in analogy to the connection of the first air conduct chamber 2a with the second air conduct chamber 2b.

The connecting piece 9 in the form of a pipe that is in the opening 8 for the outlet of air in the last air conduct chamber 2c of a column is capped with an end cap 24.

Thereby attention has to be paid on that all above mentioned connections are essentially hermetically sealed.

Then the respective required number of active ceiling areas 3 with micro-holes 4 is engaged into the two ceiling grid profiles 25 and is aligned so that an optically proper picture of gaps is formed.

Into such an inventive device is fed preferably ionized supply air. Ionized supply air is preferably prepared according to the process as described in DE 100 07 523.

In Figure 16 is shown a possible scheme according to which, based on the actual situation, an ionization of the supply air may be guaranteed. The in Figure 16 the used reference numerals have the following
5 meaning:

35 device for the air conditioning

36 device for the ionization of air

37 device for the thermal adjustment of the
supply air

10 38 room to be thermally adjusted

39 inventive flat elements 1

40 device for the control of the ionization of
the supply air, based on the actual situation

41 outdoor air conduct

15 42 supply air conduct

43 exhaust air conduct

44 discharged air conduct

45 circulating air conduct

46 air quality sensor

20 47 ozone sensor

48 air humidity sensor

49 air stream sensor

50 air quality sensor

51 controller for the supply air volume stream

52 separately hung up foil 26

5 53 laminar displacement air stream.

Due to the laminar displacement air stream obtained with the inventive device the user is located in the correspondingly air-conditioned room in a direct way in the correspondingly purified supply air stream.

10 A further advantage of the with the inventive device obtained laminar displacement air stream consists therein that on the outside, that is the visible side, of the active ceiling area 3 no particles may be deposited, and thus no essential contamination of the visible
15 surface area may occur.

Also due to the laminar displacement air stream on the visible side of the active ceiling area 3 no water vapor may condense.

20 In the present invention the following reference numerals are used:

1 flat element

2 air conduct chamber

3 active ceiling area

- 4 micro-holes
- 5 upper surface
- 6a, 6b side walls
- 7 opening for the inlet of air
- 5 8 opening for the outlet of air
- 9 connecting piece in the form of a pipe
- 10 baffle
- 11 air conduct angle
- 12 lower part of the front side of a baffle
- 10 13 lower part of the back side of a baffle
- 14 upper part of the back side of a first baffle
- 15 upper part of the front side of a second baffle
- 15 16 upper part of the front side of a first baffle
- 17 upper part of the back side of the last baffle
- 18 edges
- 20 19 free press cuts

- 20, 21 holes
- 22 side walls
- 23 fixing parts and/or arrests
- 24 end cap
- 5 25 ceiling grid profile
- 26 foil
- 27 micro-holes in the foil 26
- 28 light source
- 29 frame
- 10 30 bracket
- 31 holes
- 32 free press cuts
- 33 edges
- 34 sealing material.

Patent Claims

1. Flat element (1) - also named room element
- for thermal adjustment of indoor air, especially for
cooling of indoor air, for example in the form of a
5 ceiling element or in the form of a wall element,
whereby the form of a ceiling element is preferred,

characterized in that

it comprises an air conduct chamber (2) and an
active ceiling area (3) with micro-holes (4), whereby

10 - the air conduct chamber (2) has

-- an upper surface (5),

-- several side walls (6a, 6b),

-- at least one opening (7) for the inlet of
air,

15 -- at least one opening (8) for the outlet of
air,

whereby into each opening (7) for the inlet of
air and into each opening (8) for the outlet of air is
inserted a connecting piece (9) in the form of a pipe
20 and is essentially hermetically sealed, and

whereby the air conduct chamber (2) is open on
its bottom side,

- the active ceiling area (3) terminates the
air conduct chamber (2) on its open bottom side,

- the air conduct chamber (2) and the active ceiling area (3) are essentially hermetically sealed with each other,

- upper surface (5) of the air conduct chamber (2) is formed in such a way that it has at least one baffle (10) with at least one air conduct angle (11), whereby

-- this (these) baffle(s) (10) point(s) to the side of the active ceiling area (3), which is aligned to the inside of the flat element (1),

-- this (these) baffle(s) (10) generate(s) turbulences in an supplied air stream, and

-- this (these) baffle(s) (10) is (are) arranged crosswise to the connecting line between the opening(s) (7) for the inlet of air and the opening(s) (8) for the outlet of air, and

- the opening(s) (7) for the inlet of air and the opening(s) (8) for the outlet of air are arranged in opposite side walls (6a).

2. Flat element according to claim 1, characterized in that it comprises from two to ten baffles (10), especially two baffles (10), in the upper surface (5) of the air conduct chamber (2), and that the baffles (10) are shaped either sinuously or are cascaded, including any combinations thereof, whereby corresponding air conduct angles (11) are preferably chamfered, for example with a radius from 1 mm to 10 mm, preferably from 1 mm to 5 mm, especially of 3 mm.

3. Flat element according to one of claims 1 to 2, characterized in that the sinuously shaped baffles (10) have independent from each other the same or different wave lengths λ and with the same or different amplitudes \hat{y} , whereby an alignment with the same wave lengths λ and with the same or different amplitudes \hat{y} is preferred.

4. Flat element according to one of claims 1 to 3, characterized in that the cascaded shaped baffles (10) independent from each other are aligned symmetrically or asymmetrically and have either the same or different heights h and downs t , respectively, whereby a symmetrical alignment with the same or different heights h and downs t , respectively, is preferred.

5. Flat element according to one of claims 1 to 4, characterized in that the cross section through the respective present baffles (10) independent from each other has either the form of a triangle, especially the form of an isosceles triangle, or any polygonal form, including any combinations thereof.

6. Flat element according to one of claims 1 to 5, characterized in that in the case of a baffle (10) with a side length l of 600 mm the distance d between the lower end of the lowest air conduct angle (11) at this baffle (10) and the inward side of the active ceiling area (3) is from 1 mm to 25 mm, preferably from 1 mm to 20 mm, whereby in the presence of a plurality of baffles (10) the distance d is defined for each single baffle (10) individually.

7. Flat element according to one of claims 1 to 6, characterized in that the distance d between the

lower end of an air conduct angle (11) of a baffle (10) and the inward side of the active ceiling area (3) is adjustable by means of a profile that is attachable, preferably adhesive or screwable, to the air conduct angle (11) and/or the baffle (10), whereby this profile is preferably round-shaped, for example with a radius from 1 mm to 10 mm, preferably from 1 mm to 5 mm, especially of 3 mm, and whereby in the presence of a plurality of baffles (10) the distance d is defined individually for each single baffle (10).

8. Flat element according to one of claims 1 to 7, characterized in that in the case of cascaded shaped baffles (10) having a triangular cross section

- the angle α between the lower part of the front side (12) and lower part of the back side (13) of a baffle (10) amounts from 72° to 134° , preferably from 95° to 110° , especially about 103° ,

- the angle β between the upper part of the back side (14) of a first baffle (10) and the upper part of the front side (15) of a second baffle (10) amounts from 75° to 140° , preferably from 100° to 115° , especially about 102° ,

- the angle γ between the side wall (6a) with the opening(s) (7) for the inlet of the air and the upper part of the front side (16) of a first baffle (10) amounts from 38° to 72° , preferably from 50° to 60° , especially about 52° , and that

- the angle δ between the side wall (6a) with the opening(s) (8) for the outlet of the air and the upper part of the back side (17) of the last baffle (10)

amounts from 38° to 72°, preferably from 50° to 60°, especially about 52°,

whereby the angle γ and the angle δ have preferably the same value.

5 9. Flat element according to one of claims 1 to 8, characterized in that the upper surface (5) of the air conduct chamber (2) is made of one piece, and has the following partial elements:

10 - at the longitudinal sides located edges (18) with free press cuts (19) and with holes (20), that serve for the mounting with further parts,

15 - a first front side (6a) with an edge, that serves for the stabilization, and with one to three symmetrically arranged opening(s) (7) for the inlet of air, preferably with one in the middle arranged opening (7) for the inlet of air,

20 - a second front side (6a) with an edge, that serves for the stabilization, and with one to three symmetrically arranged opening(s) (8) for the outlet of air, preferably with one in the middle arranged opening (8) for the outlet of air, and that

25 in each opening (7) for the inlet of air and in each opening (8) for the outlet of air is inserted a connecting piece (9) in the form of a pipe and is essentially hermetically sealed, and

 - five transverse, especially perpendicular, to the shortest connecting line between an opening (7) for the inlet and an opening (8) for the outlet of air

arranged edges, along which the upper surface (5) of the air conduct chamber (2) is bent at the respective locations in an alternative way either downwards or upwards with the angles α , β , γ and δ , and thus form two baffles (10) having each a triangular cross section.

10. Flat element according to one of claims 1 to 9, characterized in that the upper surface (5) of the air conduct chamber (2) is connected with two side walls (6b) having holes (21) in an essentially hermetical way, for example with rivets ("Popnieten"), that are slided through the holes (20) in the lateral edges (18) and through the holes (21) in the side walls (6b), whereby said holes (20,21) are reconciled with each other, and whereby the side walls (6b) preferably have cut-outs, that are especially adapted to the edge guides of the present baffles (10).

11. Flat element according to one of claims 1 to 10, characterized in that on the outside of the upper surface (5) of the air conduct chamber (2) is applied an insulation material, for example a fire-proof polyurethane foam.

12. Flat element according to one of claims 1 to 11, characterized in that the air conduct chamber (2) is made of metal or of a metal alloy, for example of aluminum, zinc-plated steel plate, electrolytically zinc-plated steel plate, rustless steel plate, copper, brass.

13. Flat element according to one of claims 1 to 12, characterized in that the air conduct chamber (2) has a length from 40 cm to 160 cm, especially from 50 cm to 130 cm, preferably about 60 cm, a width from 40 cm to

80 cm, especially from 45 cm to 65 cm, preferably about 60 cm, and a height from 8 cm to 14 cm, especially from 10 cm to 14 cm, preferably about 12 cm.

14. Flat element according to one of claims 1
5 to 13, characterized in that the micro-holes (4) in the active ceiling area (3) are round and have a diameter from about 0.50 mm to about 1.20 mm, preferably from about 0.60 mm to about 1.00 mm, especially about 0.65 mm, and are present in a straight or staggered, regular
10 or irregular in-line configuration.

15. Flat element according to one of claims 1 to 14, characterized in that the active ceiling area (3) is made of a metal plate, for example an electrolytically zinc-plated steel plate, and has a thickness from
15 about 0.4 mm to about 1.5 mm, preferably from about 0.5 mm to about 0.8 mm, especially of about 0.6 mm.

16. Flat element according to one of claims 1 to 15, characterized in that the outward side, that is the visible side, of the active ceiling area (3) is left
20 in an unprocessed state or that this side is surface-treated, for example for the purpose of colouring is powder-coated.

17. Flat element according to one of claims 1 to 16, characterized in that at least two opposite side
25 walls (22) of the active ceiling area (3) have fixing parts and/or arrests (23), for example protruding embossings or neps.

18. Flat element according to one of claims 1 to 17, characterized in that the free cross-section in
30 the active ceiling area (3) is from about 1 % to about 4

%, preferably at least about 2 %, referred to the total area of the active ceiling area (3).

19. Flat element according to one of claims 1 to 18, characterized in that the essentially hermetical interconnection between the air conduct chamber (2) and the active ceiling area (3) is realized by means of a sealing material (34), for example with a weather strip, especially made of a self-adhesive cell-caoutchouc.

20. Device for thermal adjustment of indoor air, especially for cooling of indoor air, characterized in that it comprises at least one column of flat elements (1a,1b,1c) according to one of claims 1 to 19 that are essentially hermetically sealed with each other.

21. Device according to claim 20, characterized in that

- the connecting piece (9) in the form of a pipe, that is inserted in the opening (7) for the inlet of air in a first air conduct chamber (2), is connected with a conduct in which is feed in supply air,

- the connecting piece (9) in the form of a pipe, that is inserted in the opening (8) for the outlet of air in the first air conduct chamber (2), is connected with the connecting piece (9) in the form of a pipe, that is inserted in the opening (7) for the inlet of air in the second air conduct chamber (2),

- all further air conduct chambers (2) are connected with each other in analogy to the connection of the first air conduct chamber (2) with the second air conduct chamber (2),

- the connecting piece (9) in the form of a pipe, that is inserted in the opening (8) for the outlet of air in the last air conduct chamber (2) of said column, is closed with an end cap (24), and whereby

5 - all aforementioned connections are essentially hermetical.

22. Device according to one of claims 20 to 21, characterized in that the connection between the individual air conduct chambers (2) is realized by means
10 of a muffle having in its middle a stopper and with lip-seals.

23. Device according to one of claims 20 to 22, characterized in that the column of flat elements (1a,1b,1c) comprises from two to eight, especially from
15 two to six, preferably from four to six, flat elements (1a,1b,1c).

24. Device according to one of claims 20 to 23, characterized in that each air conduct chamber (2) and each active ceiling area (3) is affixed, especially
20 is hung up, individually on at least two opposite rail-shaped ceiling grid profiles (25), whereby the ceiling grid profiles (25) are affixed on hanging supports in the ceiling substructure.

25. Device according to one of claims 20 to
25 24, characterized in that the outward sides, that are the visible sides, of the active ceiling areas (3) are covered with at least one separate hung up foil (26), for example made of a textile material or made of plastics, whereby

- this foil (26) has micro-holes (27),

- the free cross-section in this foil (26) is in comparison to the free cross-section in the active ceiling area (3) either the same or is bigger, and

5 - the micro-holes (27) in the foil (26) are round and have in comparison to the micro-holes (4) in the active ceiling area (3) either the same size or are bigger and are present in a straight or staggered, regular or irregular in-line configuration, and whereby

10 the device for thermal adjustment of indoor air and the separately hung up foil (26) are essentially hermetically sealed with each other.

26. Device according to one of claims 20 to 25, characterized in that ionized supply air is feed in.

15 27. Device according to one of claims 20 to 26, characterized in that between the outward sides, that are the visible sides, of the active ceiling area (3) and the separately hung up foil (26) is arranged at least one light source (28), that is preferably fixed at
20 a lateral frame (29).

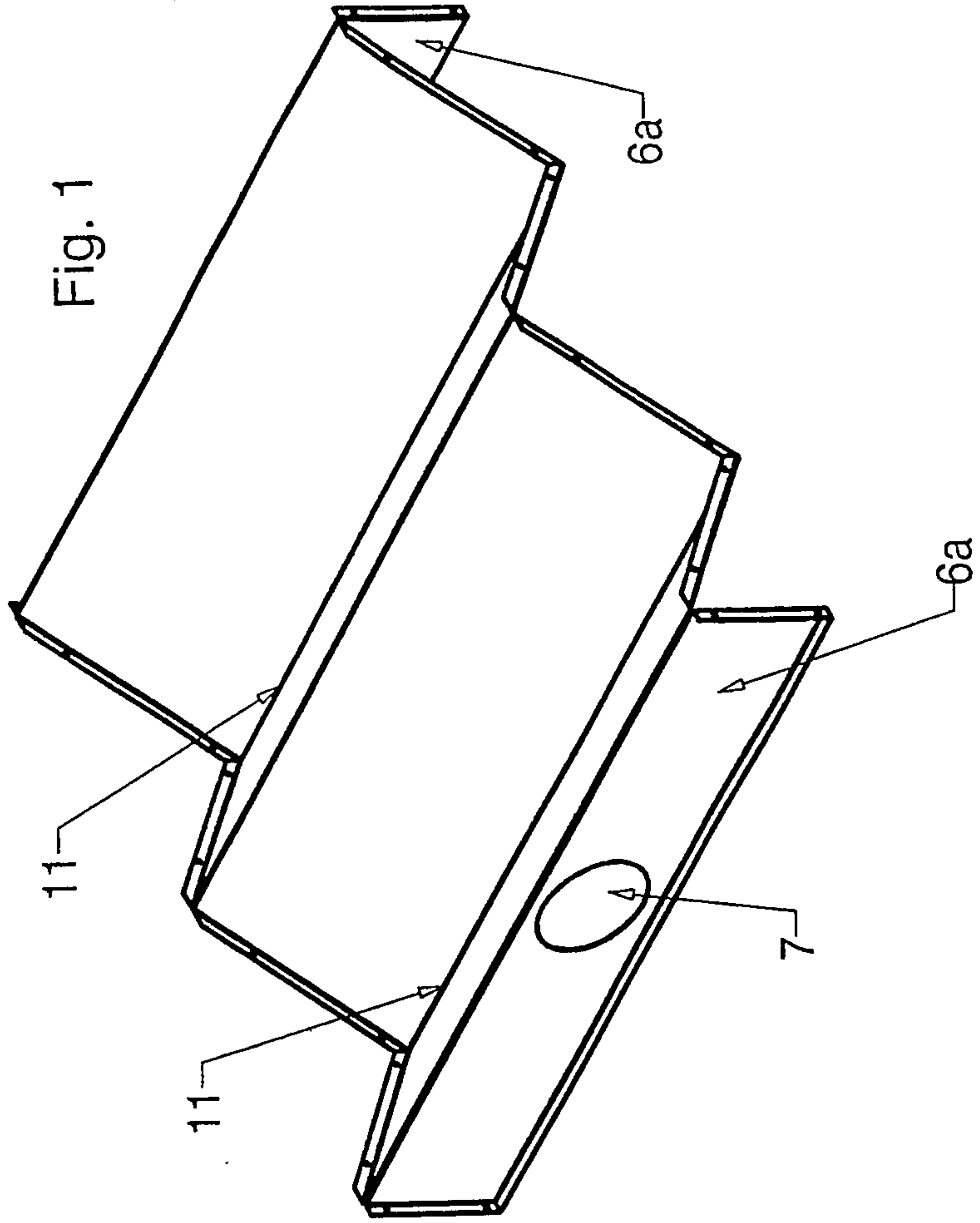
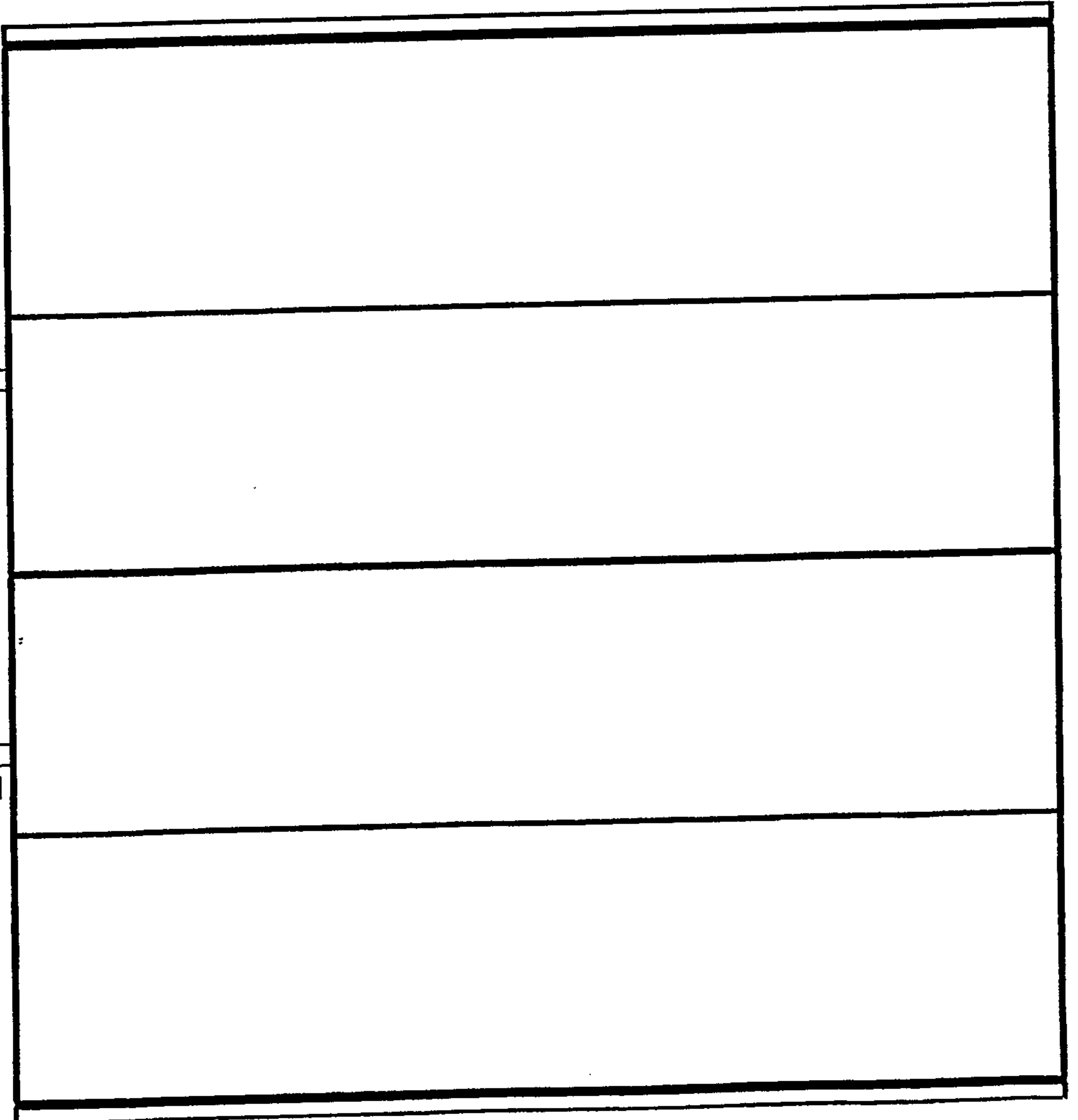
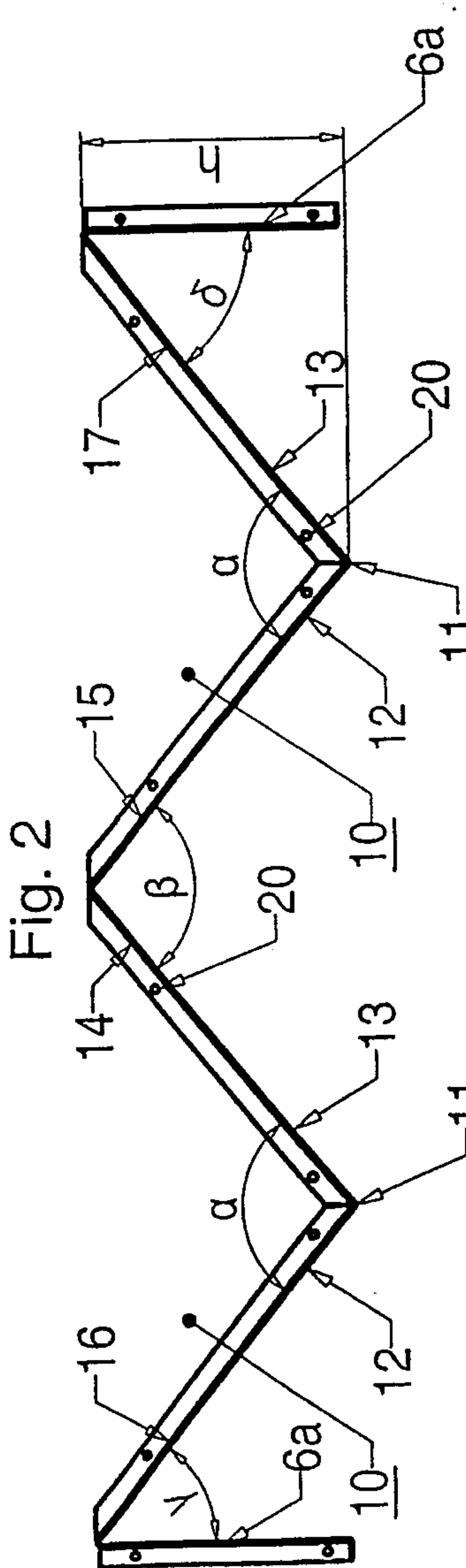

Fig. 3

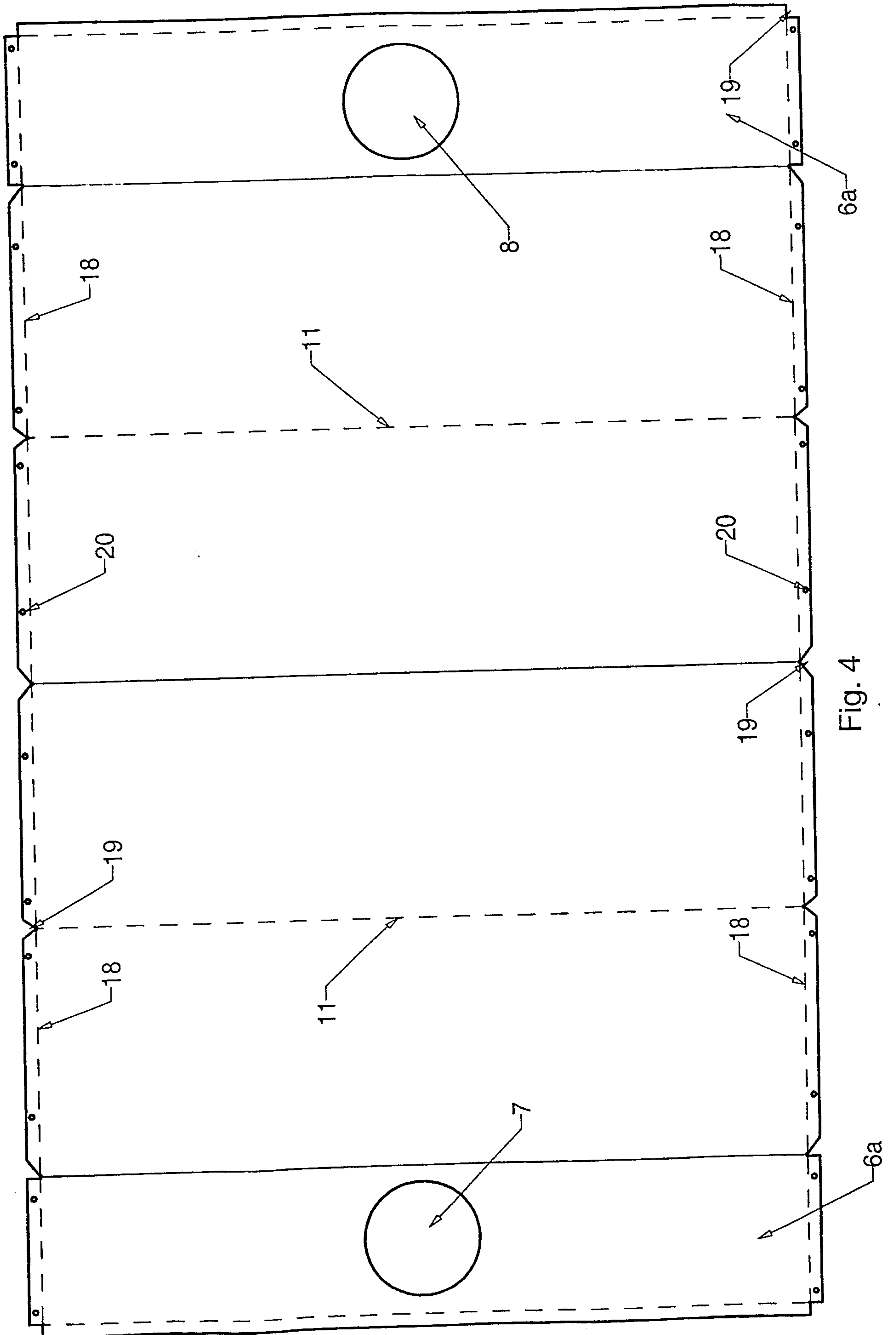
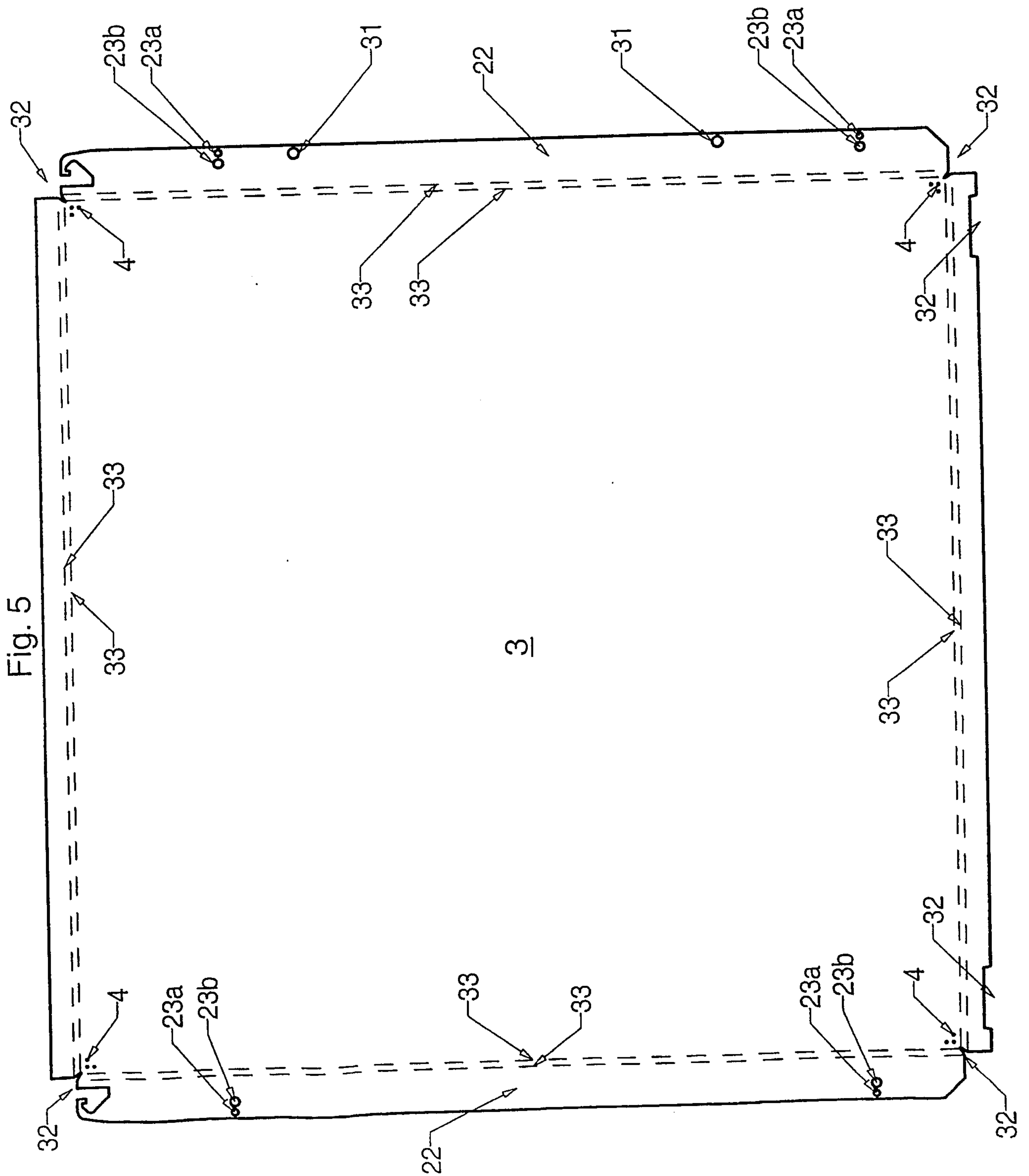
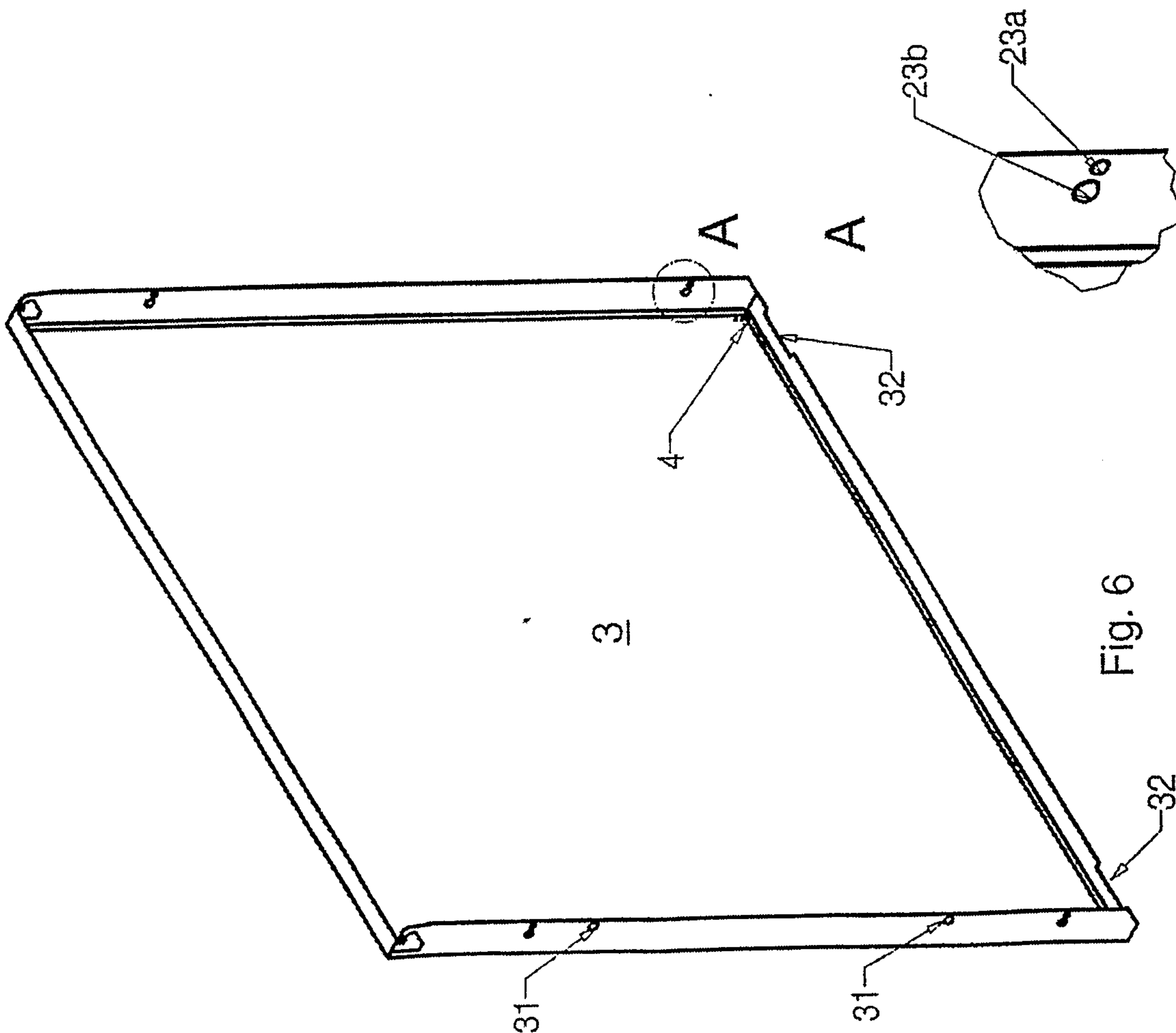
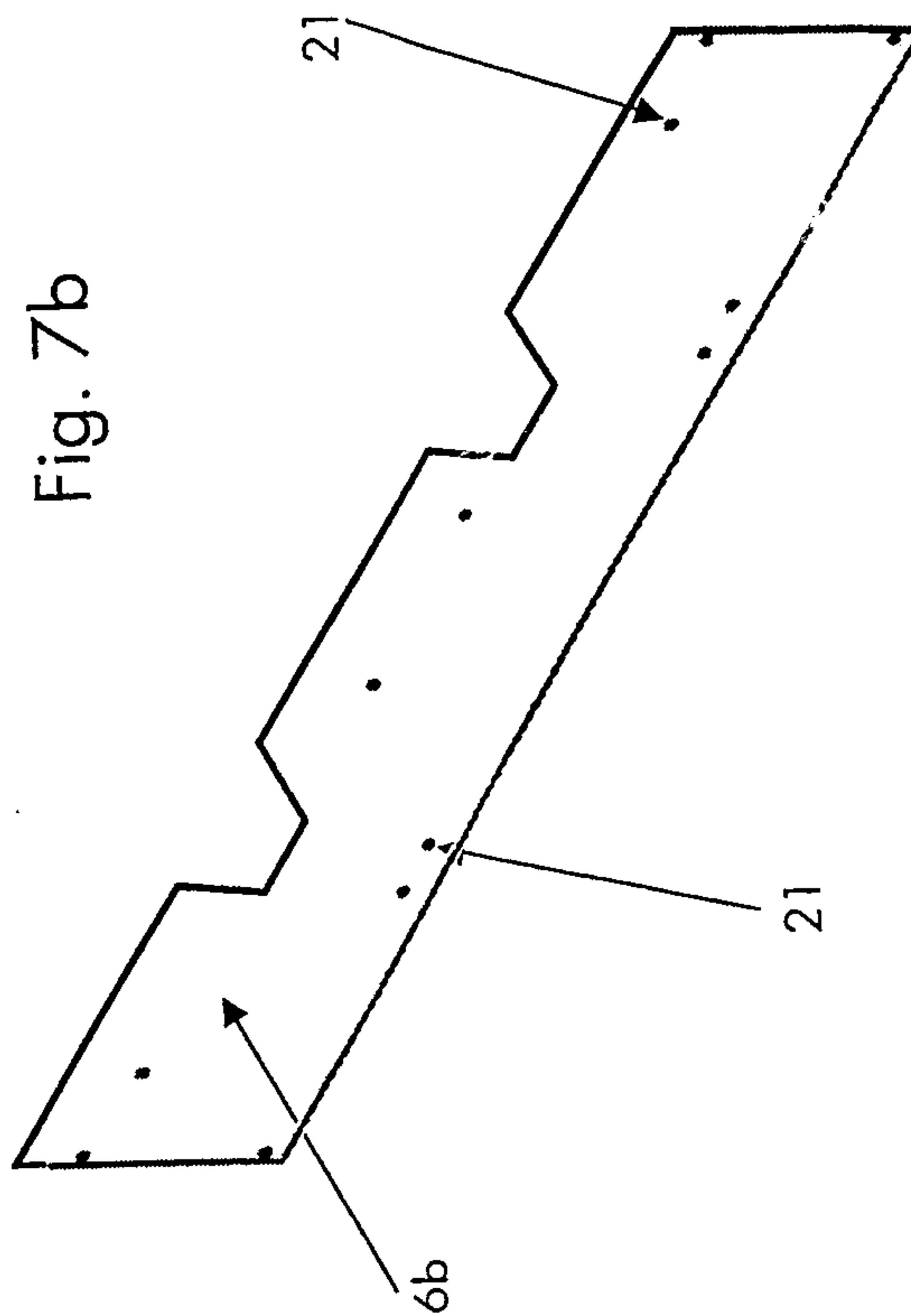
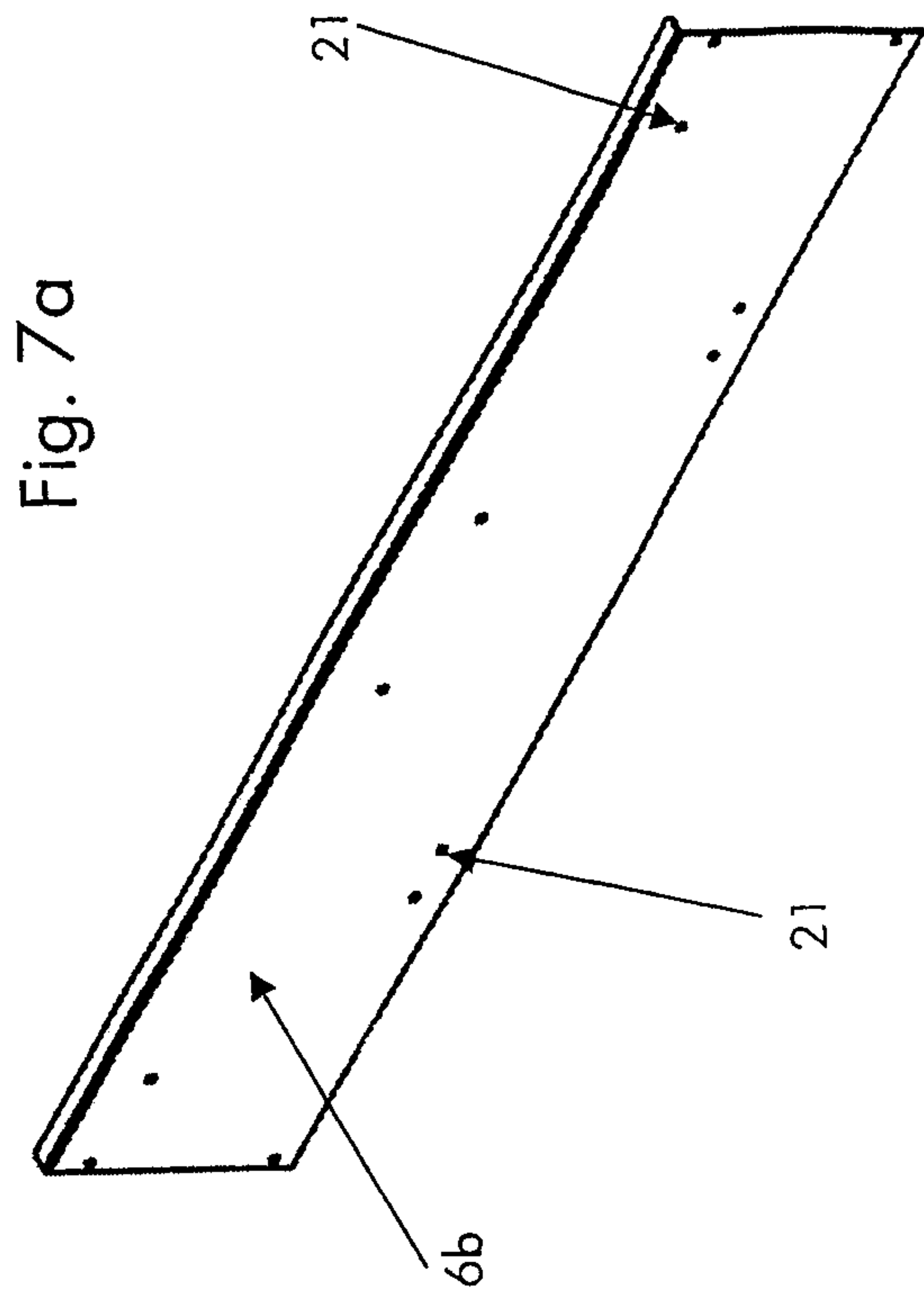

Fig. 4





5/11

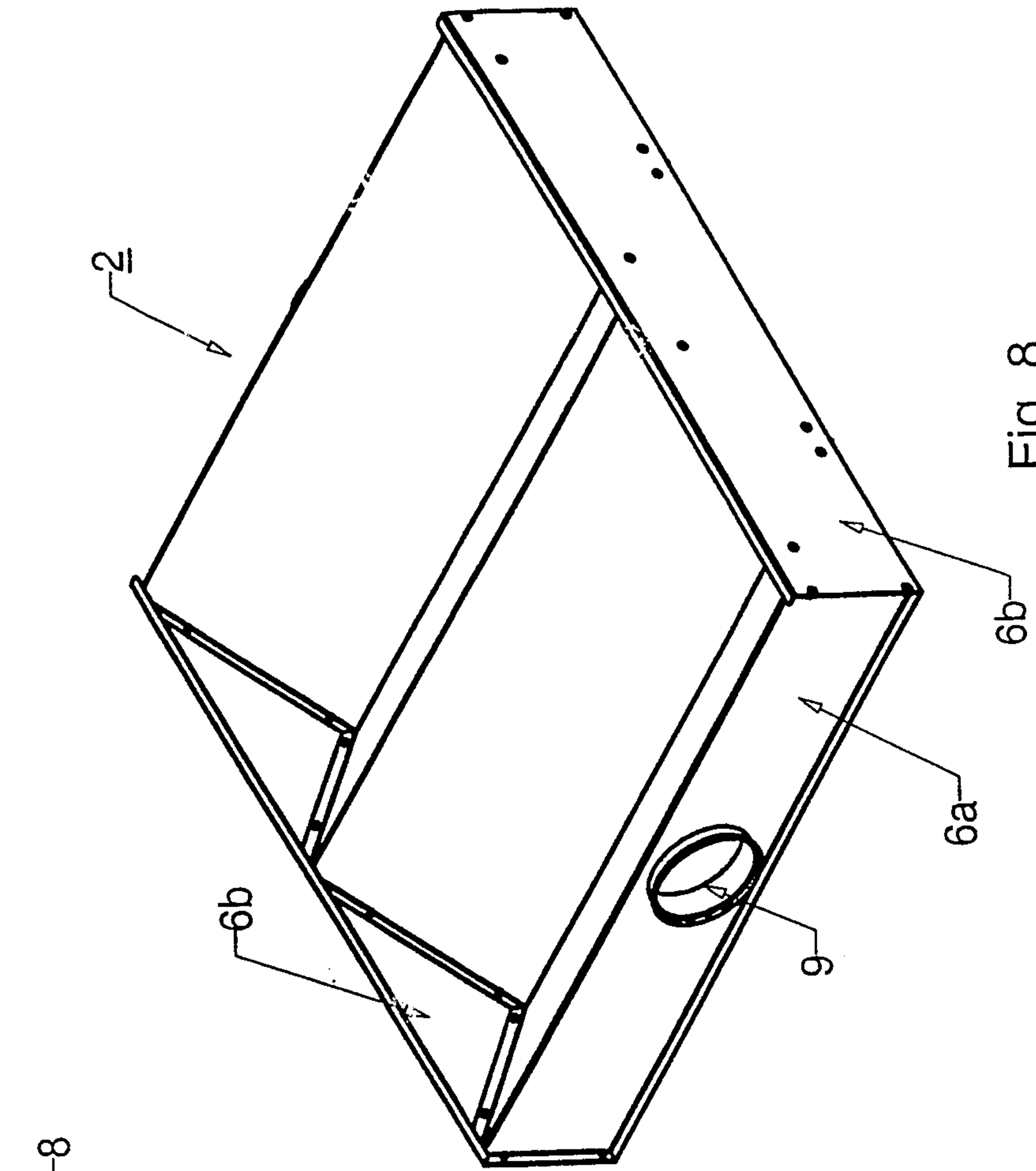

Fig. 8

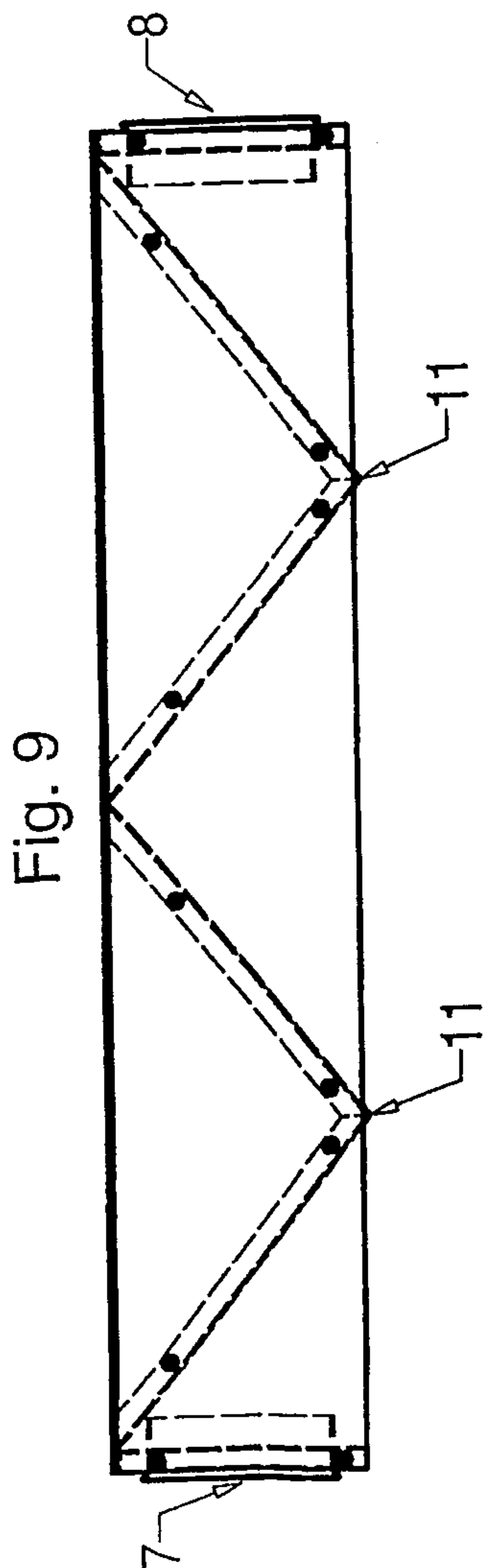

Fig. 9

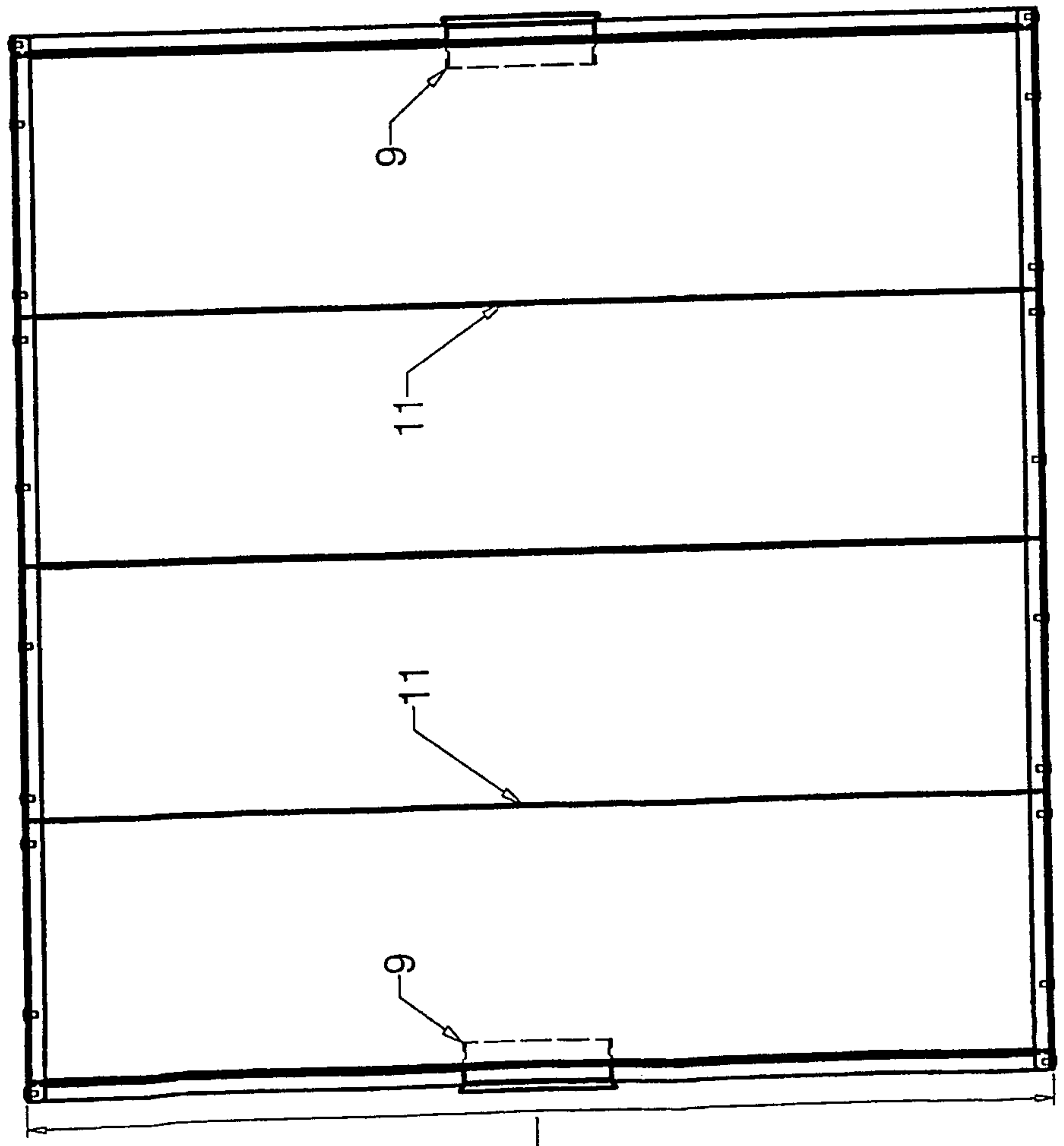

Fig. 10

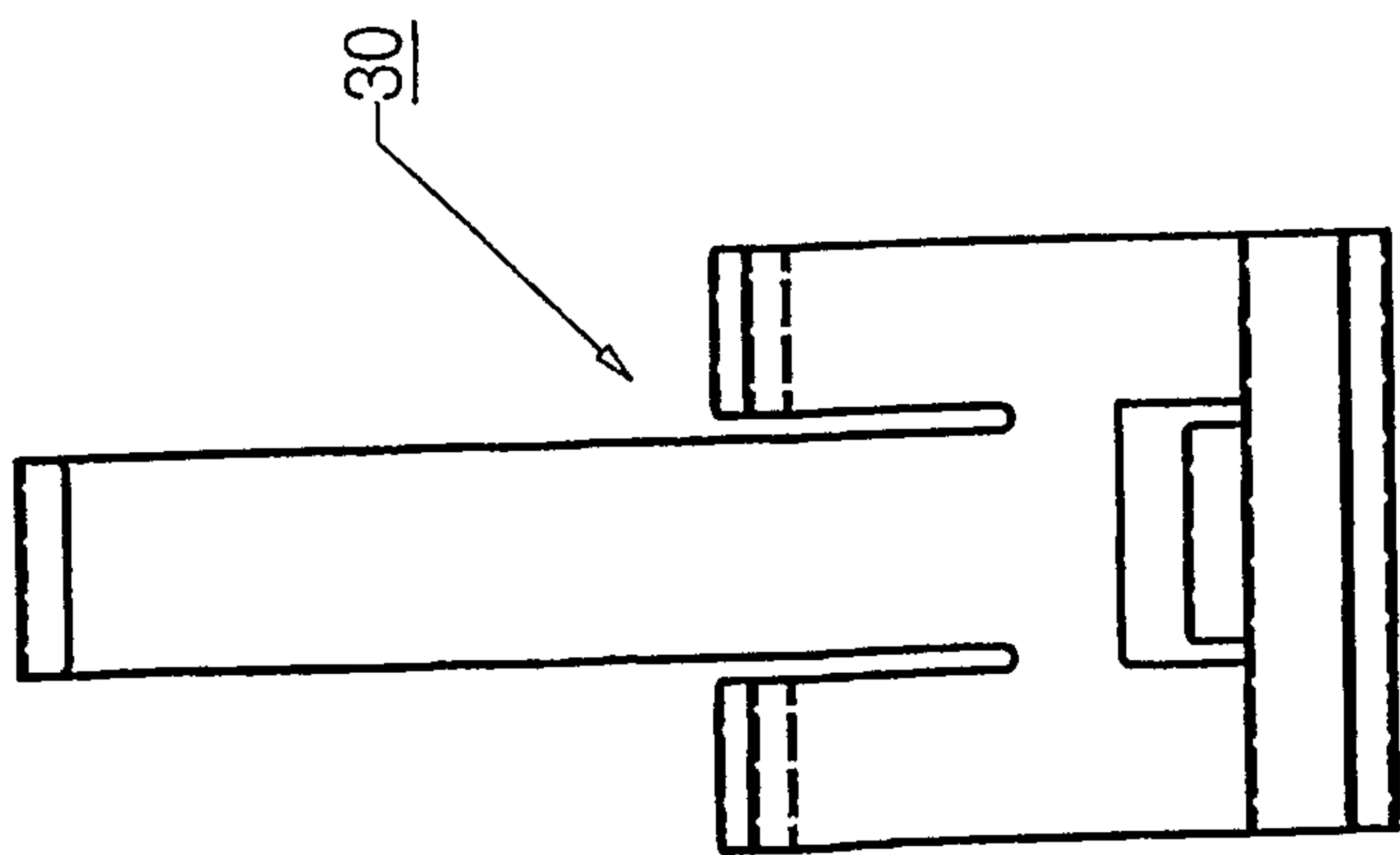

Fig. 11a

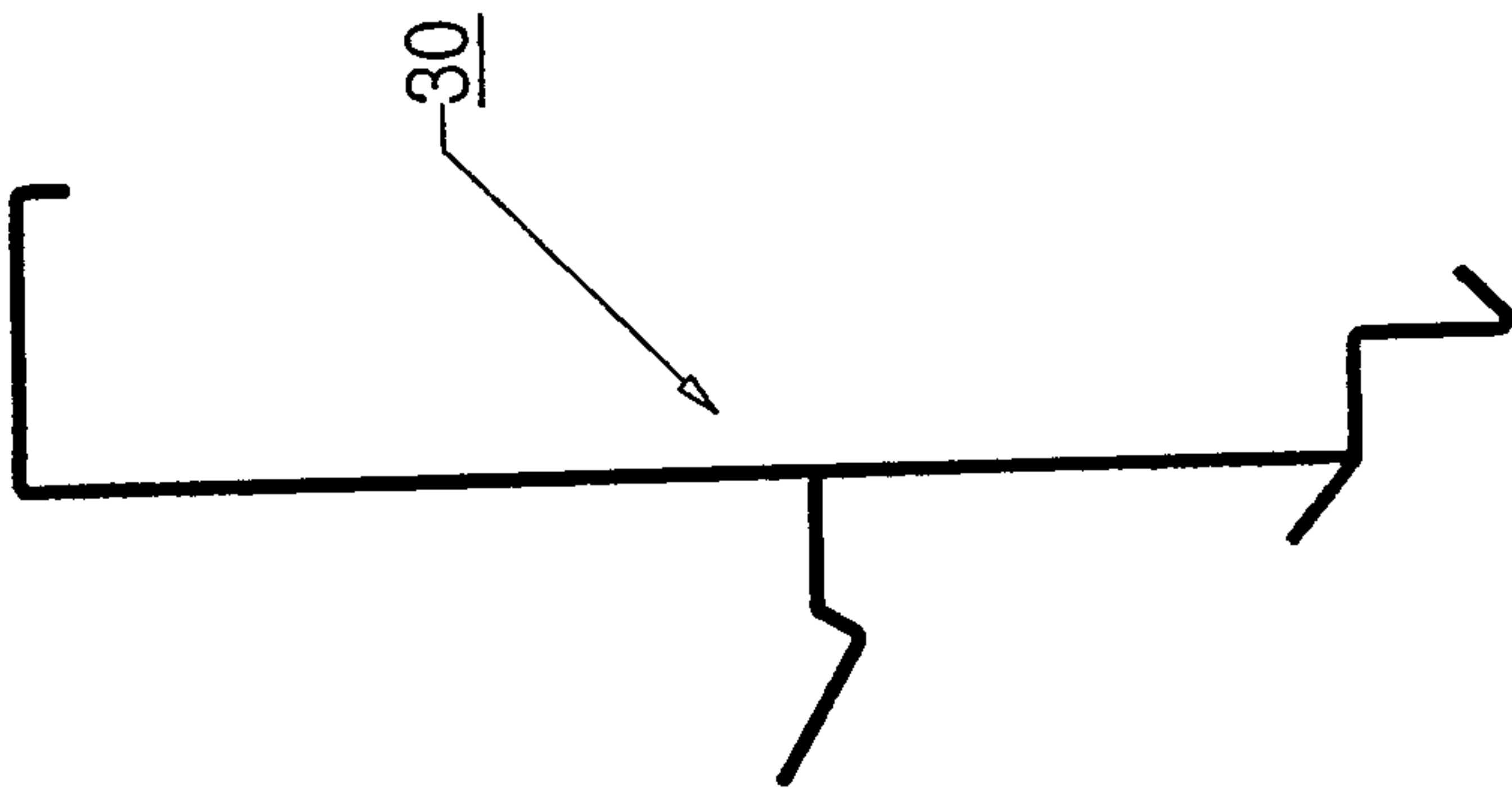

Fig. 11c

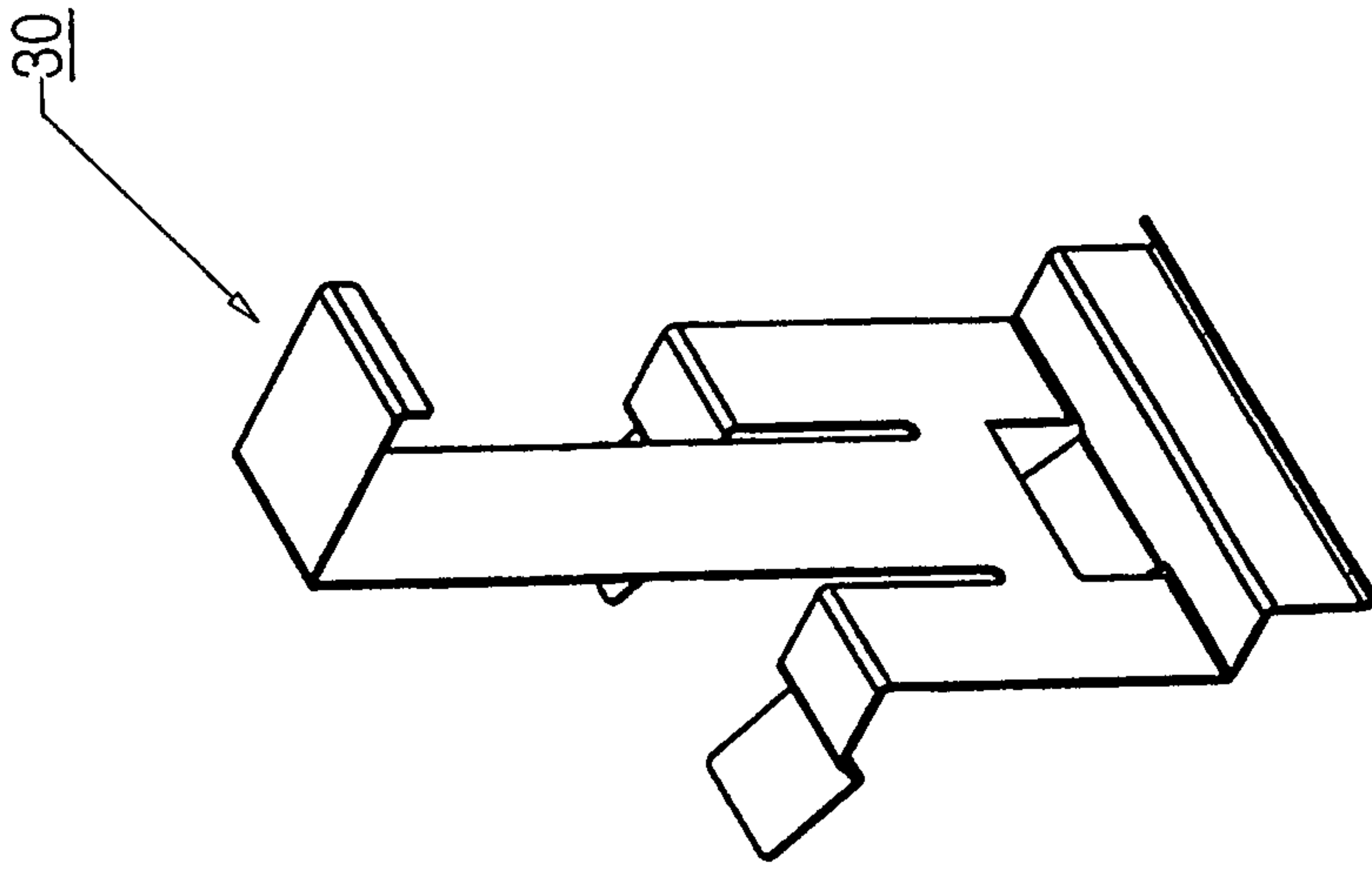

Fig. 11d

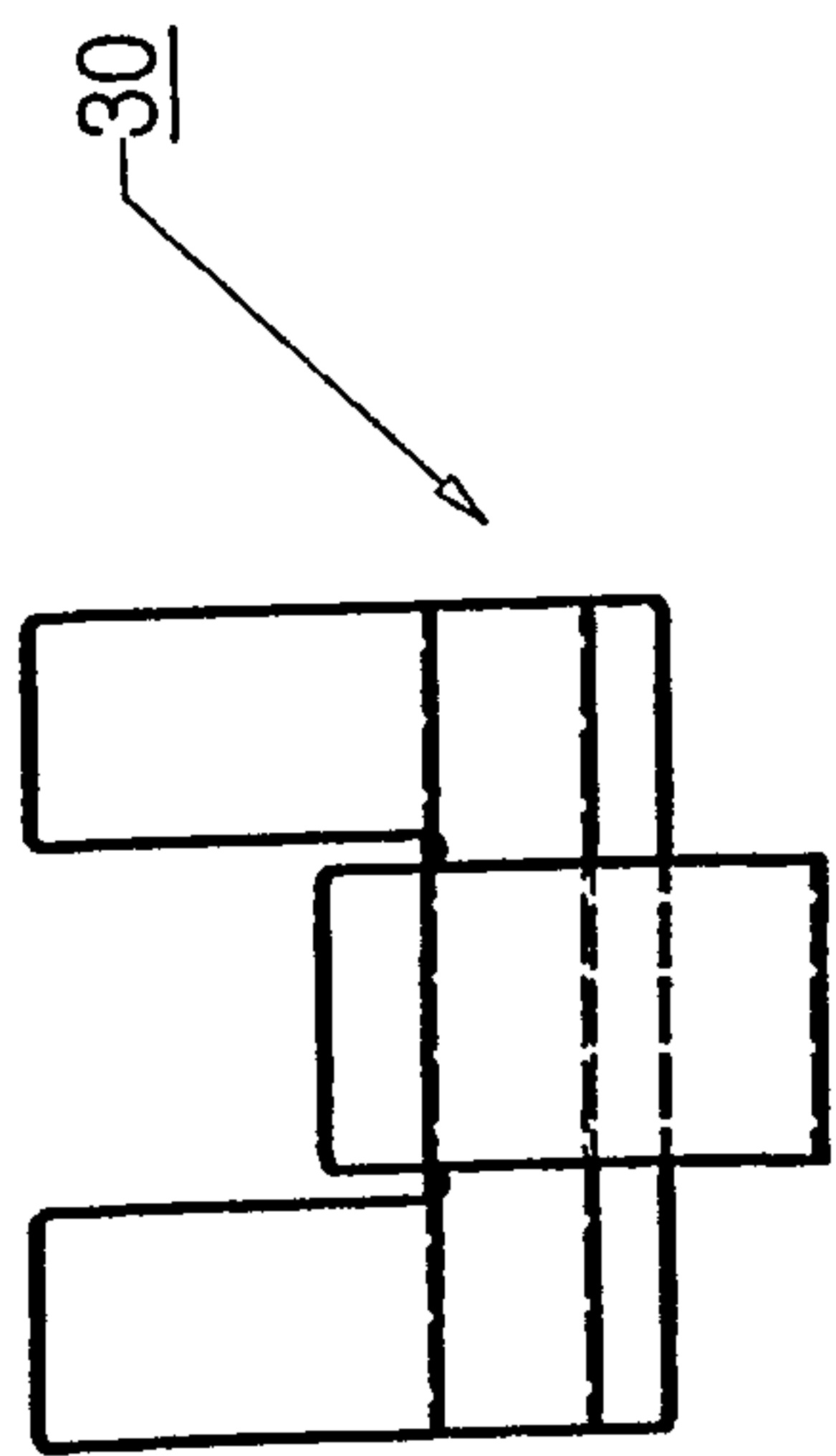

Fig. 11b

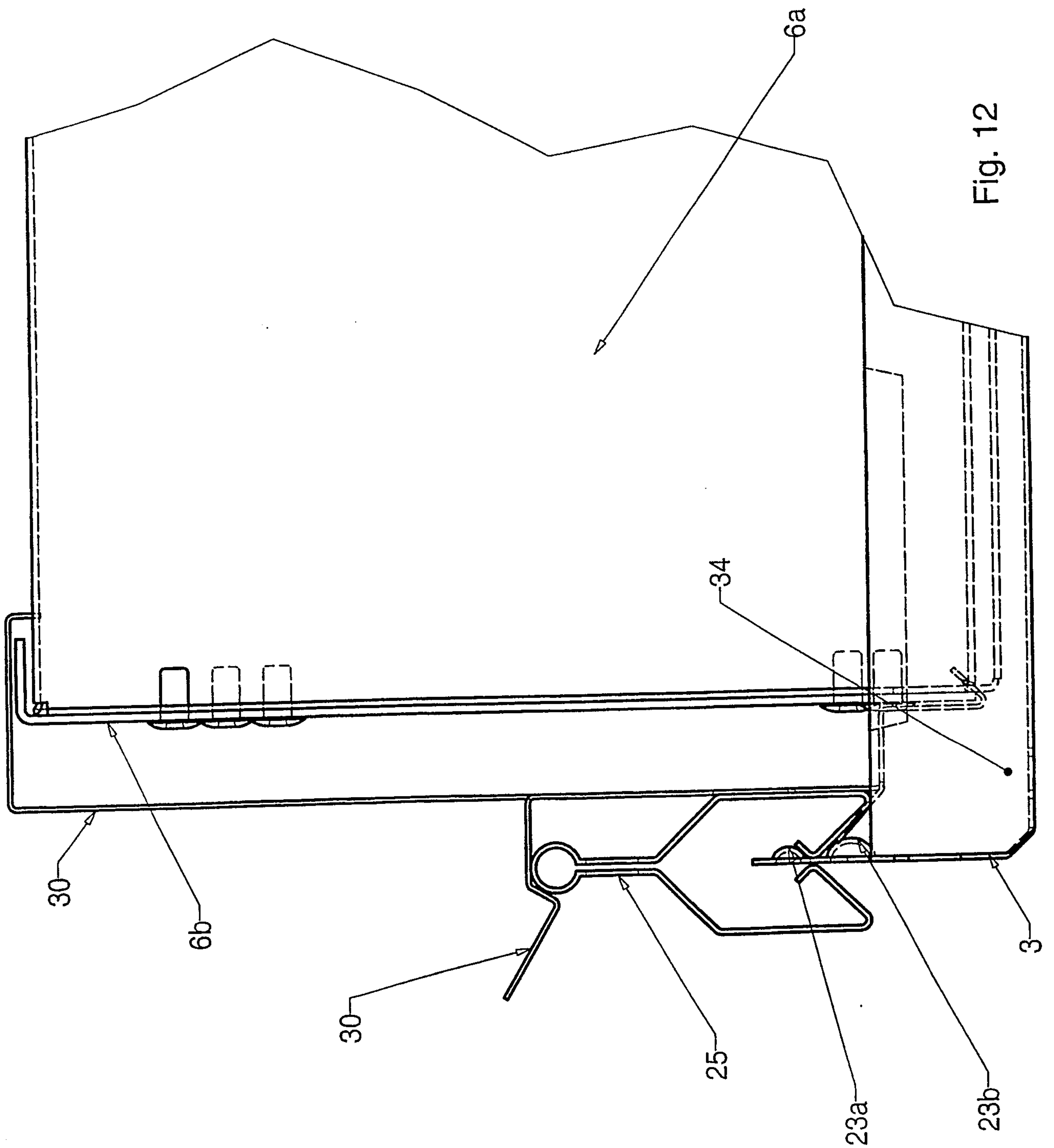

Fig. 12

Fig. 13

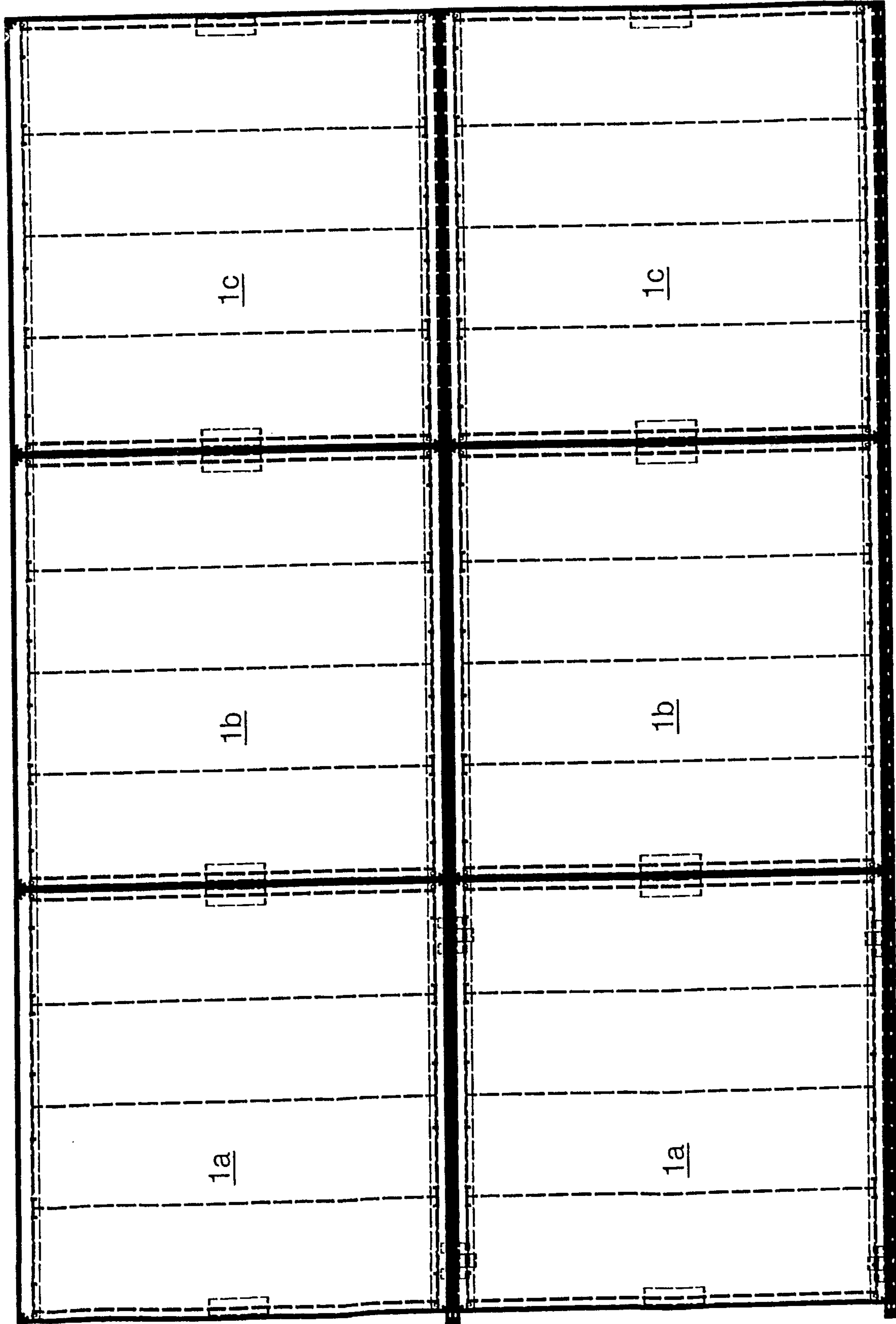
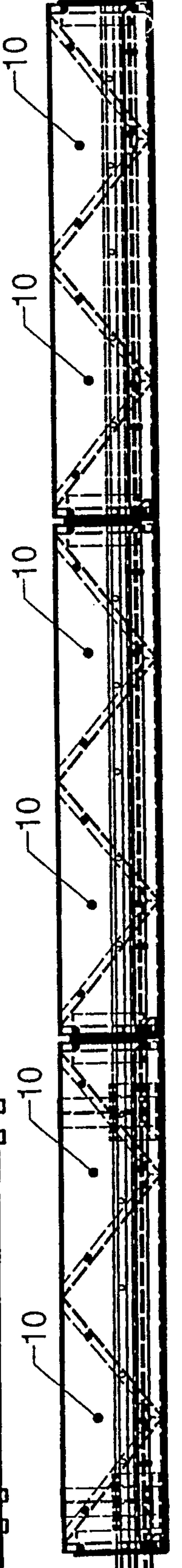

Fig. 14



9/11

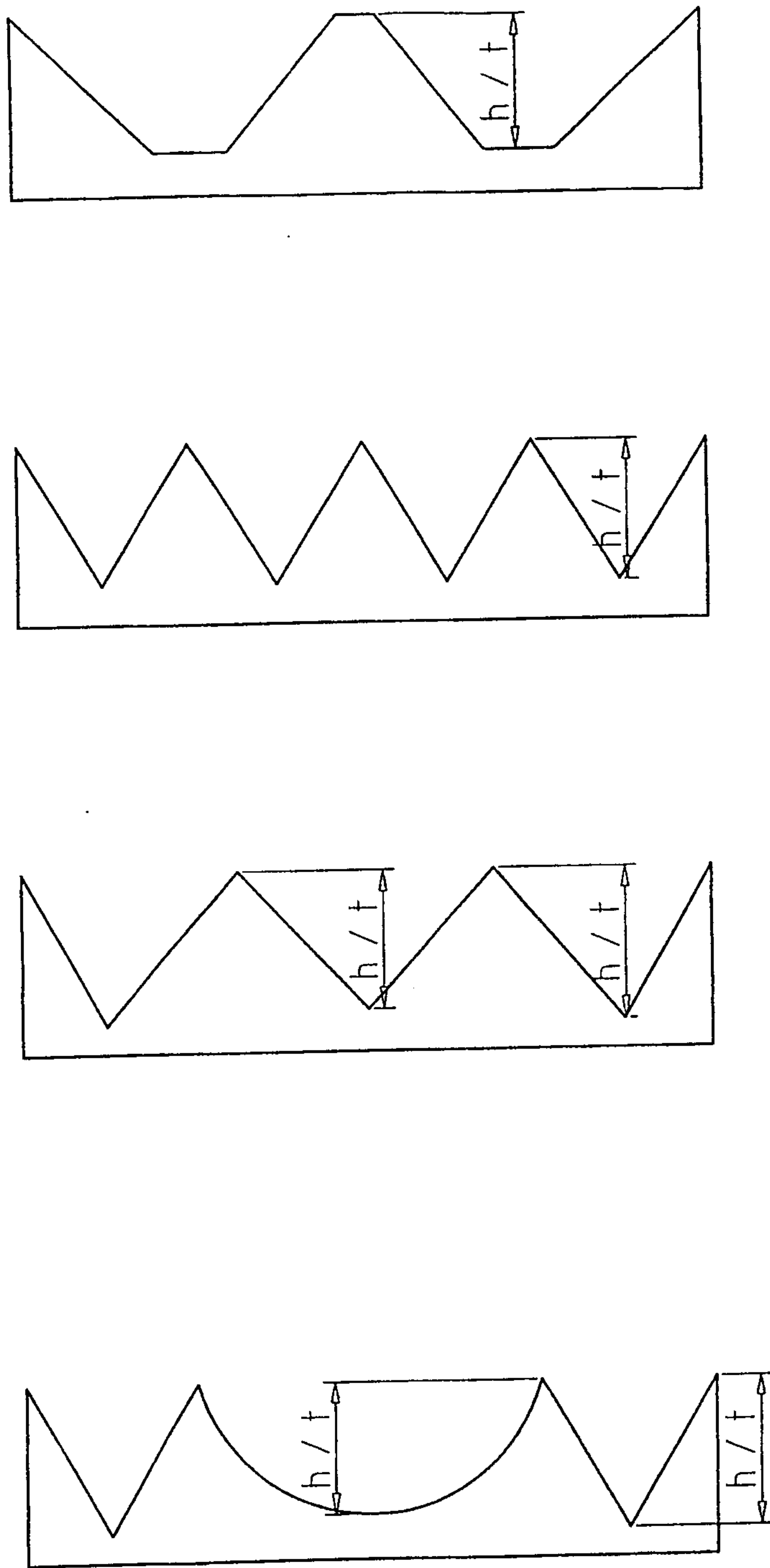

Fig. 15

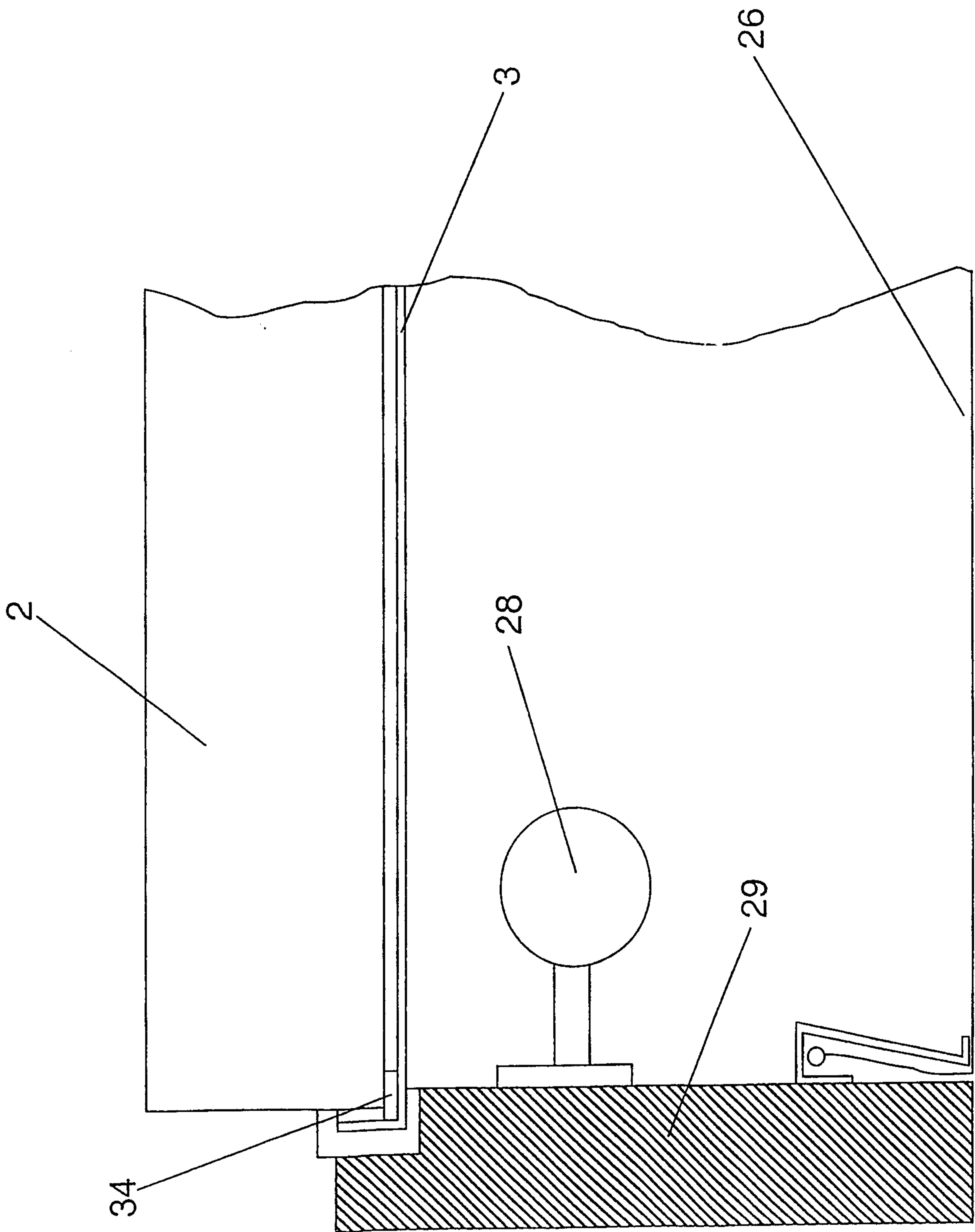

Fig. 17

--	--	--	--