



Europäisches Patentamt
European Patent Office
Office européen des brevets



(11) EP 0 723 868 A2

(12) EUROPEAN PATENT APPLICATION

(43) Date of publication:
31.07.1996 Bulletin 1996/31

(51) Int. Cl.⁶: B41J 2/175

(21) Application number: 95305512.6

(22) Date of filing: 08.08.1995

(84) Designated Contracting States:
AT BE CH DE DK ES FR GB GR IE IT LI LU MC NL
PT SE

(72) Inventor: Hayao, Sakae
Chatsworth, California 91313 (US)

(30) Priority: 22.03.1995 US 408916
27.01.1995 US 378975

(74) Representative: Neobard, William John et al
Page White & Farrer
54 Doughty Street
London WC1N 2LS (GB)

(71) Applicant: SERCOMP CORPORATION
Chatsworth, California 91313 (US)

(54) Ink cartridge holding box and ink refill kit

(57) An ink cartridge holding box for refilling a used ink cartridge with ink has an adhesive layer on a platform installed inside the box. The central area of the adhesive layer is raised so that the adhesive layer is in a contact shape, conforming to any unevenness of the underside of the used ink cartridge and for sealing the vent hole opened in the underside of the cartridge.

An ink refill kit comprises an instruction sheet and a cartridge holding box. The box is placed in a working area located at the center of the instruction sheet and the sheet has an instruction area describing steps to be taken for refilling ink.

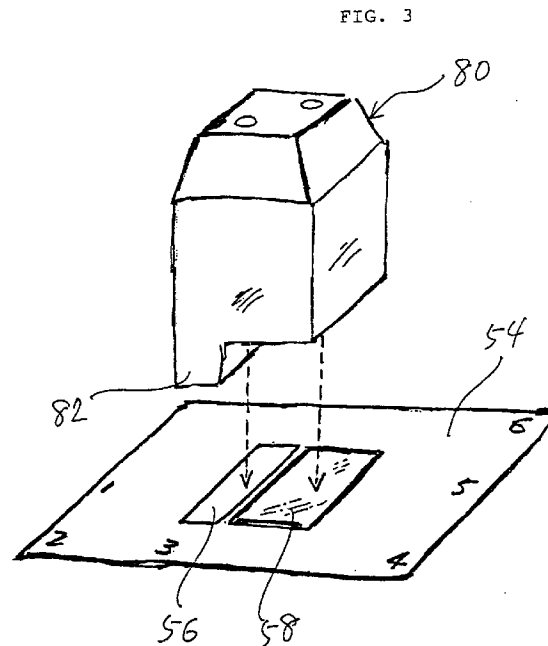

EP 0 723 868 A2

Description

The present invention relates generally to refilling of ink cartridges and more specifically to an ink cartridge holding box and to an ink refill kit including an ink cartridge holding box.

When the ink in an ink cartridge used for a computer printer is used up, a new ink cartridge is set in the printer. Recently, however, it has started to be practiced that an empty ink cartridge is refilled with ink so that the ink cartridge can be re-used.

The refilling of ink into ink cartridges is currently performed in several different ways. One of them is that an empty cartridge is set in a cartridge holding casing that has a top cover so that the empty ink cartridge is entirely inside the casing for receiving the ink. Another way of refilling ink is to use a refill adapter. One of the refill adapters invented by the inventor of the present application has been filed in the United States Patent Office under the Serial Number 08/327,280. When this refill adapted is used, an empty cartridge is held by hand and the adapter is placed on the cartridge, and then an ink tube is set on the adapter upside down so that the ink in the tube flows into the cartridge.

In the device of US Patent No 5,329,294 an ink cartridge is held by a C-shaped clamp extending from a jig that stands vertically. However, since the cartridge is held between two ends of the clamp in a lifted position, the cartridge tends to be inclined during the use. In other words, since the cartridge is held only by two points which are at both ends of the C-shaped clamp, the cartridge cannot be held in a stable manner and ink spillage occurs often.

It is accordingly one object of the present invention to at least partially overcome the above-mentioned difficulties.

According to a first aspect of the present invention there is provided an ink cartridge holding box used for holding a used ink cartridge to stand for refilling ink therein wherein said cartridge holding box is provided therein with an adhesive layer to which an underside of said cartridge may be adhered.

Under certain conditions, for example due to an uneven surface pattern formed on the underside of an ink cartridge, the ink cartridge may become loosened on the adhesive material.

Furthermore, when the ink refill act is performed, it is required to seal the vent hole that is opened in the underside of an ink cartridge. The sealing is presently accomplished by, for example, applying a rubber plug into the vent hole or by covering the hole with a plastic tape. However, if the vent hole is surrounded by a labyrinth-like pattern which is uneven or partially projects from the underside of the cartridge, a sealing of the vent hole with such means is not accomplished well, causing a leakage of ink from the vent hole.

Accordingly another object of the present invention is to at least partly overcome the above-mentioned difficulties.

According to a second aspect of the present invention there is provided an ink cartridge holding box used for refilling ink into a used empty ink cartridge comprising a main box section, a supporting block provided on an inside upper surface of a bottom of said main box section, a platform provided on top of said supporting block, said platform being formed with an opening into which a projected portion of said ink cartridge is inserted, and an adhesive layer provided on one side of said platform so as to be located next to said opening, said adhesive layer being in convex shape.

An embodiment of the present invention provides an improved ink cartridge holding box with which the vent hole of the cartridge can be sealed well and the ink cartridge can stand still without getting loosened or becoming unstable, thus assuring an efficient and clean ink refilling process.

When ink refilling is performed, the user looks at the manual that shows the steps to be taken. However, manuals usually merely lists the steps to be taken, and the intended work or ink refilling is performed with the empty cartridge positioned away from the manual. Work under these conditions is inconvenient and takes up space.

Accordingly it is a further object of the present invention to at least partly overcome the latter above-mentioned difficulties.

According to a third aspect of the present invention there is provided an ink refill kit that comprises an instruction sheet and a cartridge holding box in which the instruction sheet includes a central working area and an instruction area which surrounds the central working area with the instruction area divided into several sections containing descriptions and illustrations of steps to refill ink indicated, and the cartridge holding box which is placed in the central working area includes a cartridge holding means comprising an opening and an adhesive that are provided on a platform provided above the bottom of the cartridge holding box.

With this kit, the holding box with the ink cartridge may be placed in the central working area of the instruction sheet, and an empty cartridge placed in the cartridge holding box in a positionally secured fashion, and then the ink refilling performed in this centrally located working area following the description and illustration indicative of the steps to be taken that are shown around the central working area. Thus, the ink refill can be done easily and efficiently with an additional advantage that the area around the refilling job can be kept clean.

Embodiments of the invention will now be described with reference to the accompanying drawings in which:-

Figure 1 shows components of an ink refill kit embodying the present invention which are an instruction sheet and a cartridge holding box.

Figure 2 shows a cross section of the cartridge holding box.

Figure 3 is a perspective view showing the relationship between the platform of the cartridge holding box and the ink cartridge.

Figure 4 shows a perspective view of the ink cartridge holding box according to a second embodiment.

Figure 5 shows a front view of the cartridge holding box with the cover section thereof closed.

Figure 6 shows a cross section of the cartridge holding box with an ink cartridge set inside.

Figure 7 is an enlarged cross section showing the adhesive layer on the platform provided in the cartridge holding box.

Figure 8 is an enlarged cross section showing the adhesive layer on the platform provided in the cartridge holding box according to one modification of the present invention.

Figure 9 is an enlarged cross section showing the adhesive layer on the platform provided in the cartridge holding box according still another embodiment of the present invention.

Figure 10 shows the underside of the ink cartridge.

Referring now to Figure 1, the ink refill kit includes an instruction sheet 10 and an ink cartridge holding box 50.

The instruction sheet 10 comprises a base sheet 10C printed with a working area 10A and an instruction area 10B. The instruction sheet 10 is made of durable paper, but it can be made of any material including vinyl and plastics that have a certain strength. The instruction sheet 10 can be coated with a water-proof substance for a better durability and for keeping ink from soaking thereinto.

The working area 10A is located at the center of the instruction sheet 10, which is, in this embodiment, a rectangular shape. The instruction sheet 10 can be in any shape including a square, circle, etc. The working area 10A at the center is of a like figure to the cartridge holding box 50 and defined by thick surrounding lines which are portions of two longitudinal lines 12 and two lateral lines 14, and an intended work, an ink refilling in this embodiment, is performed in this working area 10A.

The instruction area 10B is provided so as to encircle or surround the working area 10A. The instruction area 10B is divided into a plurality of sections 10B1 through 10B6 by the longitudinal and lateral lines 12 and 14 so that each step to be taken in the ink refilling is described in each one of these sections in words and

illustrations. In addition, these sections 10B1 through 10B6 are printed with consecutive numbers from 1 through 6 counter-clockwise which represent the steps to be taken in this order. Alternatively, the steps could also be printed clockwise.

The instruction sheet 10 may be folded along the lines 12 and 14 by using these lines as creases. In other words, the sheet 10 is folded along the longitudinal lines 12 first and then along the lateral lines 14 so that the instruction sheet 10 can be put into the size of the cartridge holding box 50, thus being stored in the box 50 along with other ink refill components such as the adapter and a priming pump.

In this embodiment, each of the six (6) sections are given the following instruction statements:

In section 10B1: Peel off protective film.

In section 10B2: Firmly press used cartridge into stand.

In section 10B3: Firmly press refill adapter onto used cartridge ...

In section 10B4: Insert ink pack into refill adapter in a straight downward motion ...

In section 10B5: Insert priming pump into the vent hole ...

In section 10B6: Wipe off excess ink ...

The cartridge holding box 50 is made of durable paper and has a cover 50a. A bottom 50b of the holding box 50 is securely provided with a supporting block 52 which is size-wise about one half of the bottom 50b. The supporting block 52 is made of, for example, a liquid absorbent material so that any spilled ink can be absorbed by the supporting block 52 for example a cotton that is formed into a relatively flat block shape.

On this supporting block 52, a platform 54 which is as large in size as the bottom 52b is provided. An empty space 60 is left on one side underneath of the platform 54. The platform 54 is provided with a rectangular opening 56 that opens into the empty space 60. The opening 56 is substantially the same as or slightly larger than the bottom projected portion 82 of an ink cartridge 80 that is shown in Figure 3.

An adhesive 58, which makes a cartridge holding means along with the opening 56, is provided next to the opening 56 so as to be located above the inner end portion 52a of the supporting block 52. The adhesive 58 is a self adhesive tacky substance or pressure sensitive contact adhesive and covered by a removable thin sheet of plastic film 58a.

The platform 54 is printed with numbers 1 through 6 around the opening 56 and holding means 58. The numbers 1 through 6 positionally correspond to the numbers which appear in the sections 10B1 through 10B6 printed on the instruction sheet 10. In other words, the numbers 1 through 6 are printed, like the sections 10B1 through 10B6, counter-clockwise so that when the cartridge holding box 50 is placed in the working area 10A of the instruction sheet 10, the numbers 1 through 6 of the box 50 match the numbers of the sections 10B1 through 10B6 of the instruction sheet 10.

With the structure described above, when the ink-refill is performed, the folded instruction sheet 10 which is placed on the platform 54 is taken out of the cartridge holding box 50 and extended. Then, the cartridge holding box 50 is placed in the working area 10A of the thus extended instruction sheet 10.

When the cartridge holding box 50 is in place, the numbers 1 through 6 printed on the platform 54 of the holding box 50 and the numbers 1 through 6 printed on the instruction sheet 10 are matched, and an empty ink cartridge is set inside the cartridge holding box 50.

When the cartridge 80 is placed in the box 50, the plastic film 58a is first removed from the holding means 58, and the projected portion 82 of the cartridge 80 is pushed into the rectangular opening 56 of the platform 54 of the cartridge holding box 50. When the rectangular portion 82 is pushed, the bottom of the cartridge 80 is pressed onto the adhesive 58 of the platform 54. As a result, the ink cartridge 80 can stand upright by the opening 56 and the adhesive 58, which make a holding means, so that the cartridge 80 is firmly held inside the cartridge holding box 50 without moving horizontally nor vertically. When the cartridge 80 is thus firmly held by the holding means or by the opening 56 and the adhesive 58, the supply hole (not shown) opened in the bottom of the cartridge 80 for supplying the ink to the printer is tightly closed by the adhesive 58. Thus, the holding means not only firmly holds the ink cartridge 80 upright but also securely closes the ink outlet hole of the cartridge 80, thus preventing leakage of the ink.

Then, the user follows the steps shown in the instruction area 10B in the order of the given numbers.

As seen from the above, according to embodiments of the present invention, since the intended work which is for refilling an empty ink cartridge with ink is done at the center of the instruction sheet, and the ink cartridge is kept upright, refilling of ink can be done easily, and the surrounding area will not be contaminated by scattered and splashed ink. In addition, each step of the intended work is shown around where the intended work is performed; accordingly, such a work can be performed smoothly without skipping steps.

A second embodiment of the cartridge holding box 150 will now be described in relation to Figures 4 and 5. The cartridge holding box 150 is made of durable paper with water-proof treatment thereon and includes a main box section 152 and a cover section 154.

The main box section 152 includes a bottom plate 152a, front wall 152b, rear wall 152c and two side walls 152d. The cover section 154 extends from the upper edge of the rear wall 152c so as to open and close in a hinge-like fashion. The cover section 154 has a front flap 154a and two side flaps 154b. The front flap 154a is provided with a tab 156 that is peelable along perforations 158 formed on both sides of the tab 156. During the assembly of the box 150, the front flap 154a of the cover section 154 is glued to the outside surface of the front wall 152b of the main box section 152 with the side flaps 154b both inside the main box section 152. When

the box 150 is used as will be described below, the tab 156 is removed along the perforations 158 so that the cover section 154 can be opened.

One of the side walls 152d of the main box section 152 may have a hanging flap 152d' with a hole 152d'' therein so that the box 150 can be hung from, for example, a display stand.

On the upper surface of the bottom plate 152a of the main box section 152 is securely provided an absorbing sheet 152b', and on this absorbing sheet 152b' is a supporting block 160. The supporting block 160 is made of, for example, cotton that is formed into a relatively flat block shape. In other words, it is preferable that the supporting block 160 is made of a liquid absorbent material so that any spilled ink can be absorbed by the supporting block 160 and the absorbing sheet 152b'. The supporting block 160 is size-wise about one half of the bottom plate 152a.

On this supporting block 160, a platform 170 which is as large in size as the bottom plate 152a is provided, and an empty space 162 is left on one side underneath the platform 70. The platform 170 is provided with a rectangular opening 172 that opens into the empty space 162. The opening 172 is substantially the same as or slightly larger than the projected portion 102 of an ink cartridge 100.

On the upper surface of the platform 170 and next to the rectangular opening 172 is provided with an adhesive layer 180. The adhesive layer 180 consists of an adhesive agent such as a self adhesive tacky substance, pressure sensitive contact adhesive, etc. and is covered by a removable thin sheet of plastic film 182. The adhesive layer 180 is as large in size as the underside 104, on which a vent hole 106 and an uneven labyrinth pattern 108 are formed, of the ink cartridge 100.

In addition, a spacer 184 is provided underneath the adhesive layer 180. The spacer 184 is made of any material that can compensate for or absorb the unevenness on the surface pattern of the underside 104 of the cartridge 100. More specifically, the spacer 184 is, for example, a round thin plate with a thickness of 0.05 mm to 0.2 mm and made of a material such as rubber, plastics, etc. The spacer 184 is installed so that it is at substantially the central area of the adhesive layer 180. With this spacer 184 inserted between the adhesive layer 180 and the platform 70, the adhesive layer 80 forms substantially a convex shape when viewed from the side as seen in Figures 6 and 7.

The convex shape in the adhesive layer 180 can be obtained by bending upward a portion of the platform 170 that corresponds to substantially the central area of the adhesive layer 80 as seen in Figure 8. Furthermore, the same convex configuration may be obtained by applying an excess amount of the adhesive substance at the central area of the adhesive layer 180 on the flat portion 170 as seen in Figure 9.

In use, the cartridge holding box 150 is placed on a flat surface after removing the tab 156 along the perforations 158, and then the plastic film 182 is removed

from the adhesive layer 180. The projected portion 102 of the cartridge 100 is pushed down into the opening 172 of the platform 170 that is installed in the cartridge holding box 150.

When the projected portion 102 of the cartridge 100 is pushed down, the underside 104 of the cartridge 100 is pressed against the adhesive layer 180 which is provided on the platform 170. As a result, the ink cartridge 100 is firmly held by the adhesive layer 180 and stands upright with the help of the opening 156 into which the projected portion 102 of the cartridge 100 is pushed. The cartridge 100 is thus stably held inside the cartridge holding box 150 without moving horizontally nor vertically.

When the cartridge 100 is thus firmly held by the adhesive layer 180, the convex shape cartridge layer 180 is flattened evenly and spreads out so as to seal a vent hole 106 and conforms with the unevenness or roughness of the underside 104 of the cartridge 100. Thus, the unevenness of the underside 104 of the ink cartridge 100 is balanced out and the entire underside 104 of the ink cartridge 100 is evenly adhered to the adhesive layer 180. As a result, the cartridge 100 is held inside the cartridge holding box 150 stably and the ink refill act can be easily and cleanly performed on this firmly held cartridge 100 that is free of any looseness and free of any leakage.

After refilling the thus held cartridge 100 with ink, the cartridge 100 is removed from the adhesive layer 180, taken out of the holding box 150 and then set in an ink jet printer.

In the above description, the cartridge holding box 150 is described as placed on a flat surface so that the cartridge 100 held by the box can be re-filled with ink. It is of course also envisaged that the refilling can be performed with the box 150 set in the working area 10A of the instruction sheet 100, described with reference to Figures 1 to 3 so that the cartridge 100 is refilled in the same manner as the refilling of the cartridge 80.

The embodiments described above are to be considered in all respects as illustrative and not restrictive. The scope of the invention is indicated by the appended claims rather than the foregoing description.

Claims

1. An ink cartridge holding box used for holding a used ink cartridge to stand for refilling ink therein wherein said cartridge holding box is provided therein with an adhesive layer to which an underside of said cartridge may be adhered.
2. An ink cartridge holding box according to claim 1 wherein said adhesive layer is in a convex shape.
3. An ink cartridge holding box according to claim 1 or claim 2 further comprising a spacer provided beneath said adhesive layer.

4. An ink cartridge holding box used for holding a used ink cartridge to stand for refilling ink therein, comprising a platform provided above an inner surface of a bottom plate of said box and a cartridge holding means provided on said platform, said cartridge holding means comprising an opening, an adhesive layer provided next to said opening and a spacer provided under said adhesive layer, said opening receiving a projected portion of said ink cartridge and said adhesive layer holding an underside of said ink cartridge.
5. An ink cartridge holding box used for refilling ink into a used empty ink cartridge comprising:
 - a main box section;
 - a supporting block provided on an inside upper surface of a bottom of said main box section;
 - a platform provided on top of said supporting block, said platform being formed with an opening into which a projected portion of said ink cartridge is inserted; and
 - an adhesive layer provided on one side of said platform so as to be located next to said opening, said adhesive layer being in convex shape.
6. An ink cartridge holding box according to claim 5 further comprising a spacer installed between said adhesive layer and said platform so as to form said convex shape of said adhesive layer.
7. An ink cartridge holding box according to claim 5 wherein a part of said platform positionally corresponding to said central area of said adhesive layer is bent upwardly so as to form said convex shape of said adhesive layer.
8. An ink cartridge holding box according to claim 5 wherein an excess amount of adhesive substance is applied at said central area of said adhesive layer so as to form said convex shape of said adhesive layer.
9. An ink cartridge holding box according to any one of claims 5-8 further comprising a cover section connected to said main box section so as to open and close in a hinge-like fashion.
10. An ink refill kit for refilling ink into an empty ink cartridge comprising an instruction sheet and an ink cartridge holding box wherein:
 - said instruction sheet is provided with a working area at substantially a center of said instruction sheet and an instruction area surrounds said working area, said instruction area being divided into a plurality of sections which are printed with consecutive numbers indicative of an order of steps to be taken in refilling ink and with instruction statements and illustrations of said steps; and
 - said ink cartridge holding box is provided

with a platform over a bottom of said holding box, said platform being provided with a cartridge holding means comprising an opening and an adhesive, said opening receiving a projected portion of said ink cartridge and said adhesive securely holding a flat bottom of said ink cartridge. 5

11. An ink refill kit according to claim 10 wherein said working area and said instruction area of said instruction sheet are defined by lines crossing in longitudinal and lateral directions so that said instruction sheet is folded along said lines and stored in said cartridge holding box. 10
12. An ink refill kit according to claim 10 or claim 11 wherein said adhesive is covered by a removable thin plastic sheet. 15
13. An ink refill kit according to claim 11 or claim 12 wherein said adhesive is a pressure sensitive contact adhesive. 20
14. An ink refill kit according to any one of claims 10-12 wherein said adhesive is a self adhesive tacky substance. 25
15. An ink refill kit according to any one of claims 10-14 wherein said platform of said ink cartridge is printed with consecutive numbers that correspond to said consecutive numbers printed in said instruction area of said instruction sheet. 30
16. An ink refill kit according to any one of claims 10-15 wherein said instruction sheet is coated with a water-proof substance. 35
17. An ink refill kit according to any one of claims 10-16 wherein said platform is provided on a supporting block that is made of liquid absorbent material and secured to a bottom of said cartridge holding box. 40
18. An ink refill kit according to claim 17 wherein said absorbent material is a cotton. 45

45

50

55

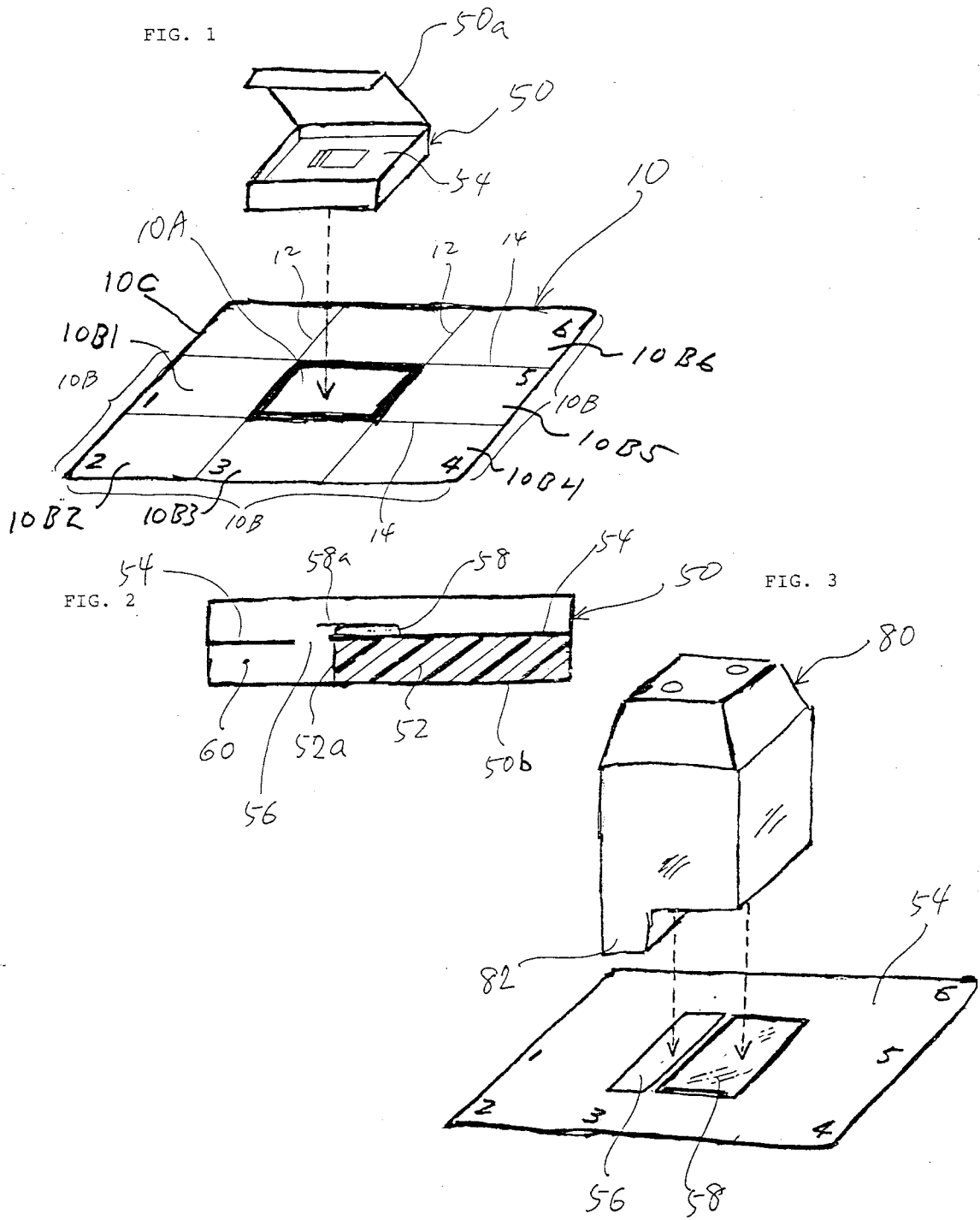

Fig. 4

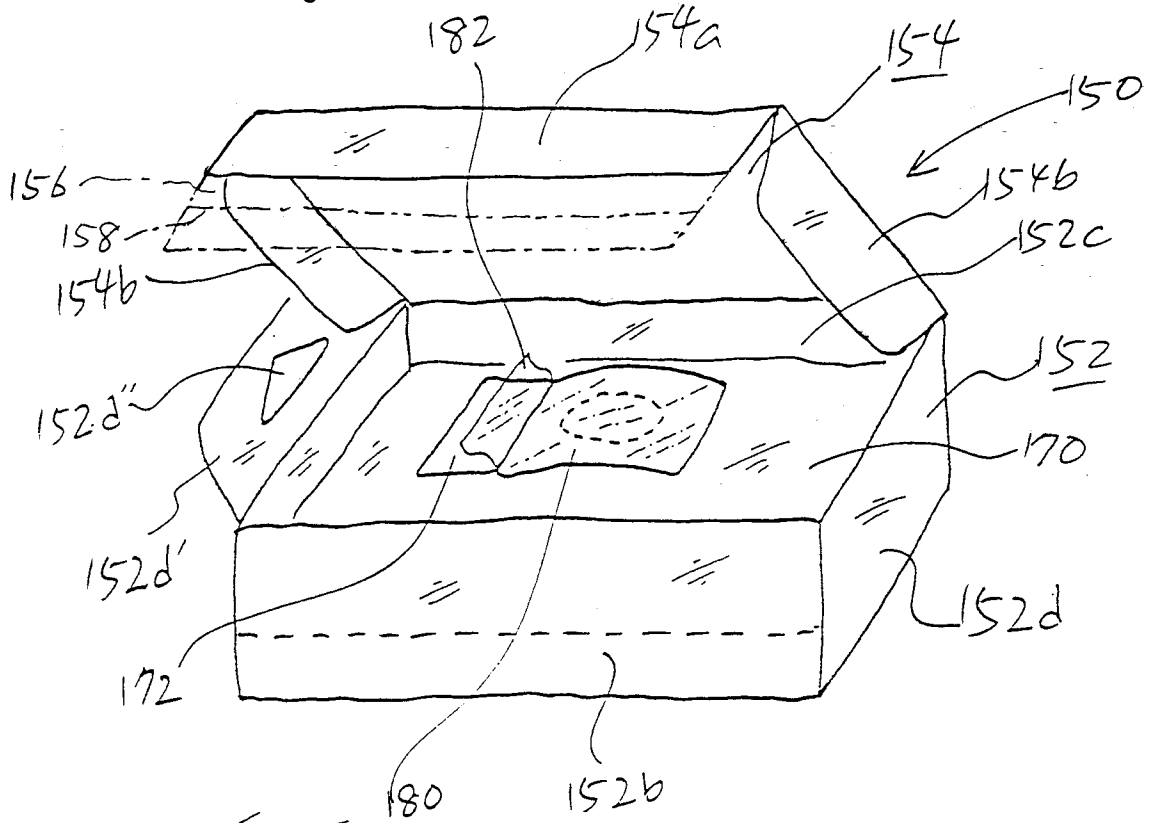

Fig. 5

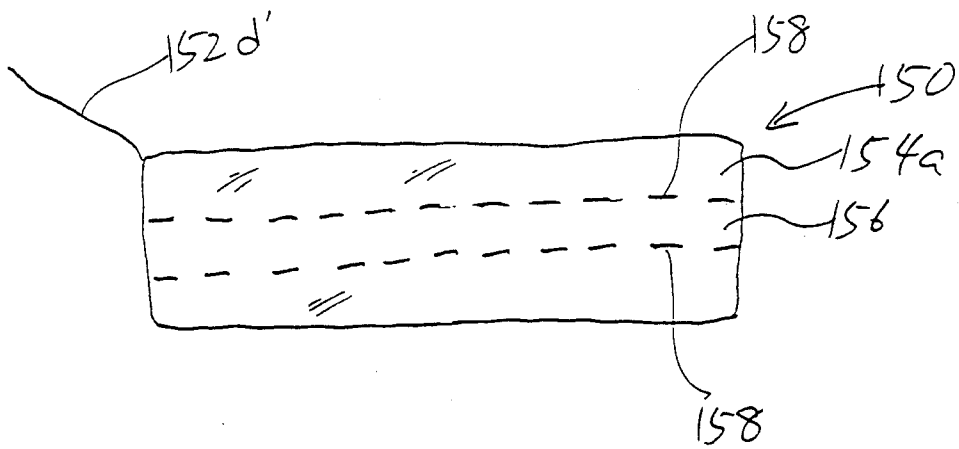

Fig. 6

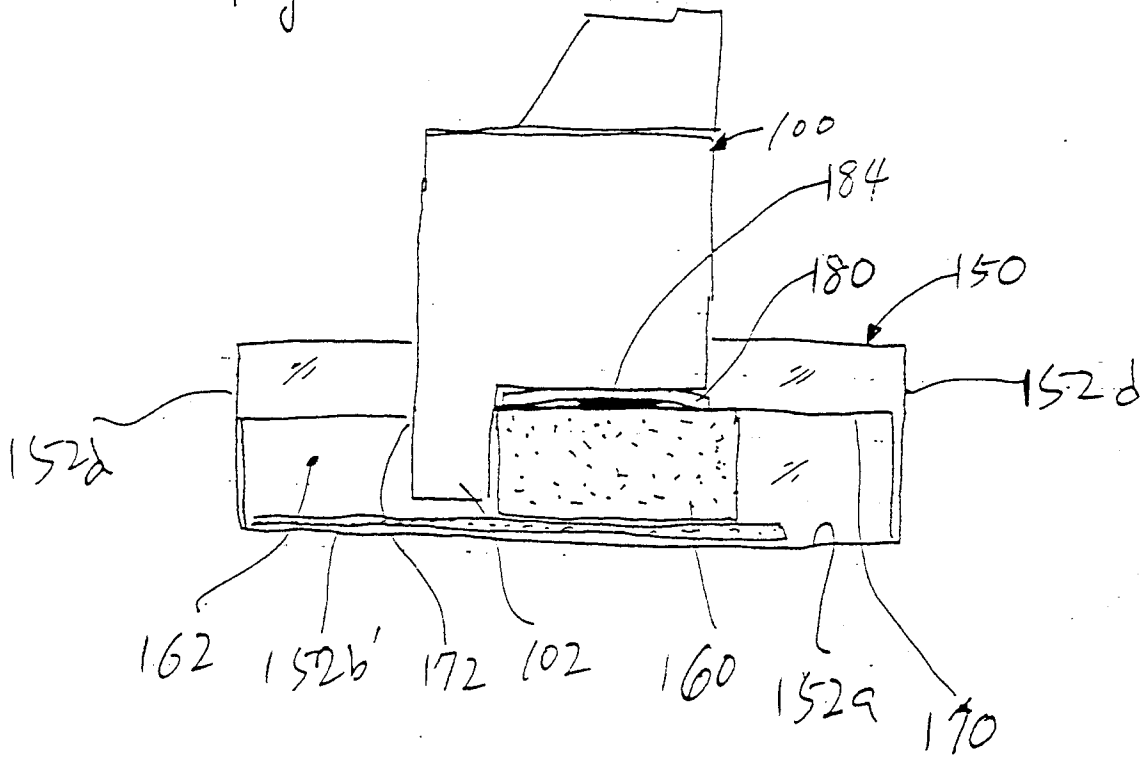

Fig. 7

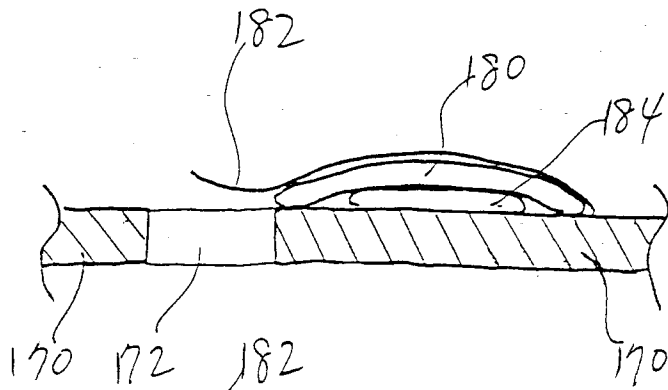

Fig. 8

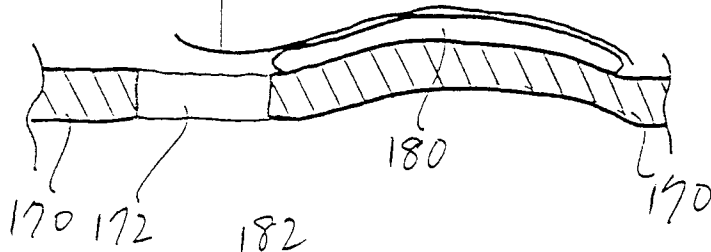

Fig. 9

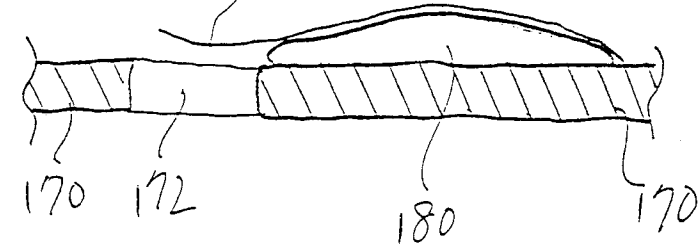

Fig. 10

