

WITNESSES:

James C. Hanson
 A. Gouldy

William G. Cowan
 Alonzo Jewett
 John S. Wardell

INVENTORS

BY

Geo. B. Wilcox

ATTORNEY

No. 707,828.

Patented Aug. 26, 1902.

W. G. COWAN, A. JEWETT & J. G. WARDELL.

ENGINE.

(Application filed Mar. 6, 1902.)

(No Model.)

2 Sheets—Sheet 2.

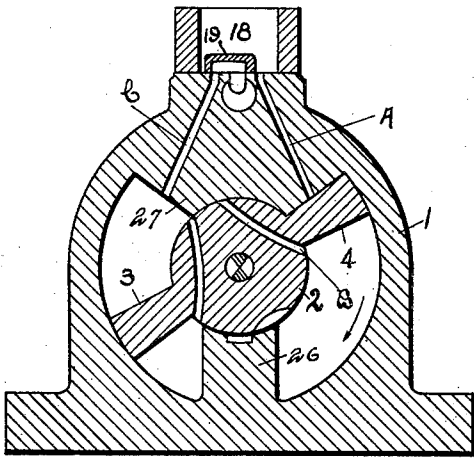

FIG 3.

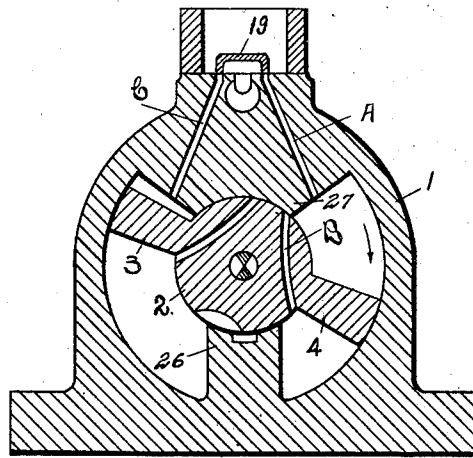

FIG 4.

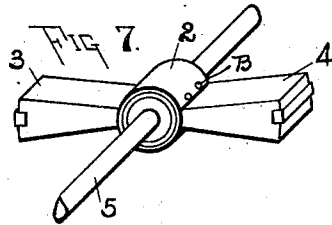

FIG 7.

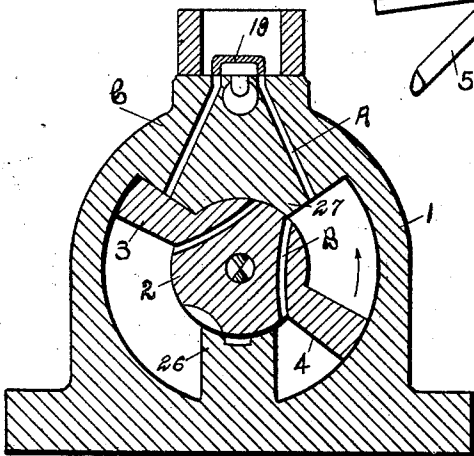

FIG 5.

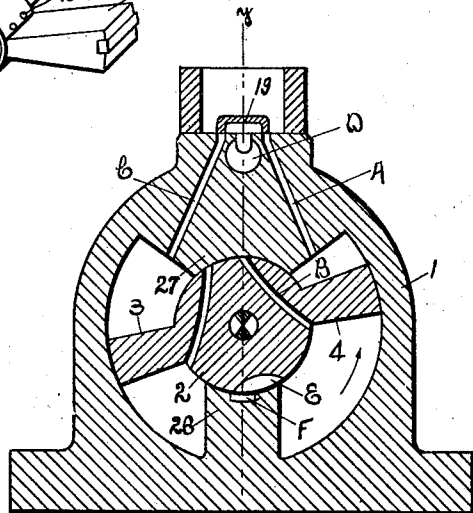

FIG 6.

WITNESSES:

James E. Henson

C. Gould

William S. Cowan
Alonso Jewett and
John S. Wardell.

INVENTORS

BY

Geo. B. Wilcox

ATTORNEY

UNITED STATES PATENT OFFICE.

WILLIAM G. COWAN AND ALONZO JEWETT, OF SAGINAW, AND JOHN G. WARDELL, OF EAST TAWAS, MICHIGAN.

ENGINE.

SPECIFICATION forming part of Letters Patent No. 707,828, dated August 26, 1902.

Application filed March 6, 1902. Serial No. 96,978. (No model.)

To all whom it may concern:

Be it known that we, WILLIAM G. COWAN and ALONZO JEWETT, residing at Saginaw, in the county of Saginaw, and JOHN G. WARDELL, residing at East Tawas, in the county of Iosco, State of Michigan, citizens of the United States, have invented certain new and useful Improvements in Engines; and we do hereby declare that the following is a full, clear, and exact description of the invention, such as will enable others skilled in the art to which it appertains to make and use the same.

This invention is a steam-engine, and the improvements relate to the construction and operation of the parts of an oscillating-piston engine of the rotary type, and more particularly to the valve arrangement and system of ports, whereby smoothness and ease of operation are attained.

With these and certain other objects in view, which will appear further in this specification and be pointed out in the claims forming a part thereof, the invention consists in the mechanism illustrated in the accompanying drawings, in which—

Figure 1 is a side elevation of the engine, broken away in parts. Fig. 2 is a top plan view. Figs. 3, 4, 5, and 6 are transverse sections through the cylinder on the line $x x$ of Fig. 2, showing diagrammatically the successive positions of the oscillating piston, the valve, and the ports during one engine cycle. Fig. 7 is a perspective view of the oscillating piston. Fig. 8 is a vertical section on the line $y y$ of Fig. 6.

As is clearly shown in the drawings, the engine consists in a cylinder or piston-chamber 1, having its axis horizontal. Within the chamber 1 is mounted a piston comprising a trunnion 2, having radiating wings 3 and 4, against which the steam acts to operate the engine. The piston is mounted on a central shaft 5, that extends through the cylinder-heads 6 and 7, and is mounted in suitable bearings 8 and 9, carried by the bed-plate 10. Fixed to the shaft 5 is an oscillating crank-arm 11, which rotates the engine-crank 12 by means of the connecting-rod 13. The engine-shaft 14 carries the crank 12 and fly-wheel 15 and is supported by bearings 16 and 17.

On top of the piston-chamber 1 is a valve-

chest 18, having ports communicating with the interior of the chamber. In the valve-chest is mounted a D slide-valve 19, that controls in part the admission and exhaust of steam to and from the piston-chamber. The slide-valve is actuated by an eccentric 20, mounted on the engine-shaft 14 and operating through the eccentric-rod 21 and a pair of diametrically opposite rocker-arms 22 and 23, mounted on the rock-shaft 24. A valve-stem 25 connects the slide-valve 19 with the upper end of the rocker-arm 23. Proper distribution of the steam in the piston-chamber 1 produces rapid oscillation of the wings or pistons 3 and 4, thus rocking the crank-arm 11 through the circular arc and imparting rotary motion to the shaft 14.

The means by which the steam distribution is accomplished forms an important feature of this invention and is as follows: Starting with the oscillating piston in the position shown in Fig. 3, steam is admitted to the valve-chest 18, and thence through the port A to the upper side of the wing 4, forcing the piston into the position shown in Fig. 4. The port A is now closed by the valve 19, and upon slight additional movement of the piston equilibrium of pressure is produced on the upper and lower sides of the wing 4. This is accomplished by means of the by-pass port B, formed in the trunnion 2. The wing 4 proceeds to the end of its stroke, as shown in Fig. 5, while the port A is still closed by the valve 19. The slide-valve then opens the port C, admitting steam on top of the wing 3, commencing the return of stroke. The wing 4 then rises to the position shown in Fig. 4, closing the port B. The valve 19 then uncovers the port A, permitting the steam to exhaust from the upper side of the wing 4 into the upper exhaust-opening D. Meanwhile the steam confined below the wing 4 expands and aids in forcing the wing 4 up. When the piston reaches the position shown in Fig. 6, the valve 19 again closes, forming a steam-cushion above the wing 4 to bring it gradually to rest. At this point the expanded steam below wing 4 discharges through the exhaust-port E, formed in the trunnion 2, and out through the lower exhaust-passage F into the atmosphere or into a suitable con-

denser. The operative cycle of the steam acting upon the wing 3 is the same as the cycle just described for the wing 4. The trunnion 2 oscillates between the lower bearing 5 26, in which the exhaust-passage F is formed, and the upper bearing 27, both bearings being formed integral with the piston-chamber 1.

By the means above described we have produced a simple, compact, and efficient engine 10 which uses the steam expansively, cushions the piston at each end of the stroke, preventing jar and vibration, and have attained these advantages in a machine having but one mechanically-operated valve and one eccentric 15 to control the entire cycle of operations.

What we claim as our invention, and desire to secure by Letters Patent, is—

1. In an engine the combination with an oscillating wing-piston, a valve-chest, ports 20 connecting the valve-chest with the piston-chamber and a slide-valve for controlling the flow through said ports; of a trunnion having a pair of by-pass ports, each arranged to connect the steam-spaces on opposite sides of a 25 wing when the wing is near the bottom of its stroke; an exhaust-port in said trunnion, arranged to discharge steam from the space underneath the wing when the wing is near the top of its stroke; and an exhaust-passage 30 in the engine-cylinder, arranged to register with the exhaust-port of the trunnion when the wing is near the top of its stroke, sub-

stantially as described and for the purposes set forth.

2. In an engine the combination of an oscillating trunnion mounted within the engine-cylinder and carrying diametrically opposite wings; ports for admitting and discharging steam from the spaces above said wings; a slide-valve for controlling said ports; a pair 40 of by-pass ports formed in the trunnion, each port being arranged to connect the steam-spaces on opposite sides of a wing when the wing is near the bottom of its stroke; an exhaust-port in the lower side of the trunnion, 45 arranged to discharge steam from the space underneath the wing when the wing is near the top of its stroke; an exhaust-passage in the engine-cylinder, arranged to register with the exhaust-port of the trunnion when the 50 wing is near the top of its stroke; an oscillating arm secured to said trunnion and arranged to actuate a rotating shaft, together with means operated by said shaft for actuating the slide-valve. 55

In testimony whereof we affix our signatures in the presence of two witnesses.

WILLIAM G. COWAN.
ALONZO JEWETT.
JOHN G. WARDELL.

Witnesses:

H. J. SEARS,
MINA A. DAVISON.