

(19) World Intellectual Property Organization
International Bureau



(43) International Publication Date
6 December 2007 (06.12.2007)

PCT

(10) International Publication Number
WO 2007/140367 A2

(51) International Patent Classification:
H04R 25/00 (2006.01)

(74) Agents: HAN, Johnney, U. et al.; Levine Bagade Han LLP,
2483 E. Bayshore Road, Suite 100, Palo Alto, California
94303 (US).

(21) International Application Number:
PCT/US2007/069885

(81) Designated States (unless otherwise indicated, for every
kind of national protection available): AE, AG, AL, AM,
AT, AU, AZ, BA, BB, BG, BH, BR, BW, BY, BZ, CA, CH,
CN, CO, CR, CU, CZ, DE, DK, DM, DO, DZ, EC, EE, EG,
ES, FI, GB, GD, GE, GH, GM, GT, HN, HR, HU, ID, IL,
IN, IS, JP, KE, KG, KM, KN, KP, KR, KZ, LA, LC, LK,
LR, LS, LT, LU, LY, MA, MD, ME, MG, MK, MN, MW,
MX, MY, MZ, NA, NG, NI, NO, NZ, OM, PG, PH, PL,
PT, RO, RS, RU, SC, SD, SE, SG, SK, SL, SM, SV, SY,
TJ, TM, TN, TR, TT, TZ, UA, UG, US, UZ, VC, VN, ZA,
ZM, ZW.

(22) International Filing Date: 29 May 2007 (29.05.2007)

(25) Filing Language: English

(26) Publication Language: English

(30) Priority Data:
60/809,244 30 May 2006 (30.05.2006) US
60/820,223 24 July 2006 (24.07.2006) US

(71) Applicant (for all designated States except US): SONI-
TUS MEDICAL, INC. [US/US]; 830 Menlo Avenue,
Suite 201, Menlo Park, California 94025 (US).

(72) Inventors; and

(75) Inventors/Applicants (for US only): ABOLFATHI,
Amir [US/US]; 2150 Stockbridge Avenue, Woodside, Cal-
ifornia 94062 (US). SPIRIDIGLIOZZI, John [US/US];
338 S Fremont Street, #115, San Mateo, California 94401
(US).

(84) Designated States (unless otherwise indicated, for every
kind of regional protection available): ARIPO (BW, GH,
GM, KE, LS, MW, MZ, NA, SD, SL, SZ, TZ, UG, ZM,
ZW), Eurasian (AM, AZ, BY, KG, KZ, MD, RU, TJ, TM),
European (AT, BE, BG, CH, CY, CZ, DE, DK, EE, ES, FI,
FR, GB, GR, HU, IE, IS, IT, LT, LU, LV, MC, MT, NL, PL,

[Continued on next page]

(54) Title: METHODS AND APPARATUS FOR TRANSMITTING VIBRATIONS

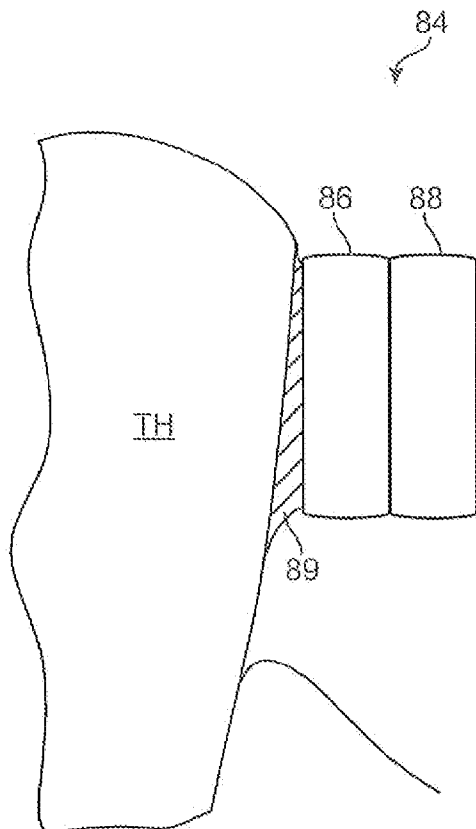

(57) Abstract: Methods and apparatus for transmitting vibrations via an electronic and/or transducer assembly through a tooth or teeth are disclosed herein. The assembly may include a bracket which is adhered or affixed onto the tooth or teeth and an electronics and/or transducer assembly which may be removably coupled to the bracket. The electronic and/or transducer assembly may receive incoming sounds either directly or through a receiver to process and amplify the signals and transmit the processed sounds via a vibrating transducer element coupled to the bracket for transmission into the underlying tooth or other bone structure.

WO 2007/140367 A2



PT, RO, SE, SI, SK, TR), OAPI (BF, BJ, CF, CG, CI, CM, GA, GN, GQ, GW, ML, MR, NE, SN, TD, TG).

For two-letter codes and other abbreviations, refer to the "Guidance Notes on Codes and Abbreviations" appearing at the beginning of each regular issue of the PCT Gazette.

Published:

— *without international search report and to be republished upon receipt of that report*

METHODS AND APPARATUS FOR TRANSMITTING VIBRATIONS

CROSS-REFERENCE TO RELATED APPLICATIONS

[0001] This application claims the benefit of priority to U.S. Prov. Pat. Apps. 60/809,244 filed May 30, 2006 and 60/820,223 filed July 24, 2006, each of which is
5 incorporated herein by reference in its entirety.

FIELD OF THE INVENTION

[0002] The present invention relates to methods and apparatus for transmitting vibrations through teeth or bone structures in and/or around a mouth. More particularly,
10 the present invention relates to methods and apparatus for sound conduction through teeth or bone structures in and/or around the mouth by transmitting vibrations correlating to auditory signals received by a user.

BACKGROUND OF THE INVENTION

15 [0003] Hearing loss affects over 31 million people in the United States (about 13% of the population). As a chronic condition, the incidence of hearing impairment rivals that of heart disease and, like heart disease, the incidence of hearing impairment increases sharply with age.

[0004] While the vast majority of those with hearing loss can be helped by a well-
20 fitted, high quality hearing device, only 22% of the total hearing impaired population own hearing devices. Current products and distribution methods are not able to satisfy or reach over 20 million persons with hearing impairment in the U.S. alone.

[0005] Hearing loss adversely affects a person's quality of life and psychological well-being. Individuals with hearing impairment often withdraw from social interactions
25 to avoid frustrations resulting from inability to understand conversations. Recent studies have shown that hearing impairment causes increased stress levels, reduced self-confidence, reduced sociability and reduced effectiveness in the workplace.

[0006] The human ear generally comprises three regions: the outer ear, the middle ear, and the inner ear. The outer ear generally comprises the external auricle and the ear
30 canal, which is a tubular pathway through which sound reaches the middle ear. The outer

ear is separated from the middle ear by the tympanic membrane (eardrum). The middle ear generally comprises three small bones, known as the ossicles, which form a mechanical conductor from the tympanic membrane to the inner ear. Finally, the inner ear includes the cochlea, which is a fluid-filled structure that contains a large number of delicate sensory hair cells that are connected to the auditory nerve.

5 [0007] Hearing loss can also be classified in terms of being conductive, sensorineural, or a combination of both. Conductive hearing impairment typically results from diseases or disorders that limit the transmission of sound through the middle ear. Most conductive impairments can be treated medically or surgically. Purely conductive hearing loss represents a relatively small portion of the total hearing impaired population (estimated at less than 5% of the total hearing impaired population).

[0008] Sensorineural hearing losses occur mostly in the inner ear and account for the vast majority of hearing impairment (estimated at 90-95% of the total hearing impaired population). Sensorineural hearing impairment (sometimes called “nerve loss”) is largely caused by damage to the sensory hair cells inside the cochlea. Sensorineural hearing impairment occurs naturally as a result of aging or prolonged exposure to loud music and noise. This type of hearing loss cannot be reversed nor can it be medically or surgically treated; however, the use of properly fitted hearing devices can improve the individual’s quality of life.

15 [0009] Conventional hearing devices are the most common devices used to treat mild to severe sensorineural hearing impairment. These are acoustic devices that amplify sound to the tympanic membrane. These devices are individually customizable to the patient’s physical and acoustical characteristics over four to six separate visits to an audiologist or hearing instrument specialist. Such devices generally comprise a microphone, amplifier, battery, and speaker. Recently, hearing device manufacturers have increased the sophistication of sound processing, often using digital technology, to provide features such as programmability and multi-band compression. Although these devices have been miniaturized and are less obtrusive, they are still visible and have major acoustic limitation.

20 [0010] Industry research has shown that the primary obstacles for not purchasing a hearing device generally include: a) the stigma associated with wearing a hearing device;

b) dissenting attitudes on the part of the medical profession, particularly ENT physicians; c) product value issues related to perceived performance problems; d) general lack of information and education at the consumer and physician level; and e) negative word-of-mouth from dissatisfied users.

5 [0011] Other devices such as cochlear implants have been developed for people who have severe to profound hearing loss and are essentially deaf (approximately 2% of the total hearing impaired population). The electrode of a cochlear implant is inserted into the inner ear in an invasive and non-reversible surgery. The electrode electrically stimulates the auditory nerve through an electrode array that provides audible cues to the
10 user, which are not usually interpreted by the brain as normal sound. Users generally require intensive and extended counseling and training following surgery to achieve the expected benefit.

[0012] Other devices such as electronic middle ear implants generally are surgically placed within the middle ear of the hearing impaired. They are surgically
15 implanted devices with an externally worn component.

[0013] The manufacture, fitting and dispensing of hearing devices remain an arcane and inefficient process. Most hearing devices are custom manufactured, fabricated by the manufacturer to fit the ear of each prospective purchaser. An impression of the ear canal is taken by the dispenser (either an audiologist or licensed hearing instrument
20 specialist) and mailed to the manufacturer for interpretation and fabrication of the custom molded rigid plastic casing. Hand-wired electronics and transducers (microphone and speaker) are then placed inside the casing, and the final product is shipped back to the dispensing professional after some period of time, typically one to two weeks.

[0014] The time cycle for dispensing a hearing device, from the first diagnostic
25 session to the final fine-tuning session, typically spans a period over several weeks, such as six to eight weeks, and involves multiple with the dispenser.

[0015] Accordingly, there exists a need for methods and devices which are efficacious and safe in facilitating the treatment of hearing loss in patients as well as for providing efficient methods for attaching such devices as well as for removing them from
30 the user's mouth without compromising performance.

SUMMARY OF THE INVENTION

[0016] An electronic and transducer device may be attached, adhered, or otherwise embedded into or upon a removable dental or oral appliance to form a hearing aid assembly or attached directly to the tooth or upper or lower jaw bone. Such a removable oral appliance may be a custom-made device fabricated from a thermal forming process
5 utilizing a replicate model of a dental structure obtained by conventional dental impression methods. The electronic and transducer assembly may receive incoming sounds either directly or through a receiver to process and amplify the signals and transmit the processed sounds via a vibrating transducer element coupled to a tooth or other bone
10 structure, such as the maxillary, mandibular, or palatine bone structure.

[0017] The assembly for transmitting vibrations via at least one tooth may generally comprise, in one variation, a housing having a shape which is conformable to at least a portion of the at least one tooth, and an actuatable transducer disposed within or upon the housing and in vibratory communication with a surface of the at least one tooth.
15 Moreover, the transducer itself may be a separate assembly from the electronics and may be positioned along another surface of the tooth.

[0018] In other variations utilizing multiple components, generally a first component may be attached to the tooth or teeth using permanent or semi-permanent adhesives while a second removable component may be attached, adhered, or otherwise
20 affixed to the first component. Examples of adhesives for attaching the first component to the tooth or teeth may include cements and epoxies intended to be applied and/or removed by a healthcare provider. Examples of typical dental cements include, but are not limited to, zinc oxide eugenol, zinc phosphate, zinc silico-phosphate, zinc-polyacrylate, zinc-polycarboxylate, glass ionomer, resin-based, silicate-based cements, etc.

[0019] The first component can contain any, all, or none of the mechanisms and/or electronics (e.g., actuators, processors, receivers, etc.) while the second component, which can be attached to the first component, can also contain any combination of the mechanisms and/or electronics, such as the battery. These two components may be temporarily coupled utilizing a variety of mechanisms, e.g., electromagnetic, mechanical
25 attachment, chemical attachment, or a combination of any or all of these coupling
30 mechanisms.

[0020] In one example, an electronics and/or transducer assembly may define a channel or groove along a surface for engaging a corresponding dental anchor or bracket which may comprise a light-curable acrylate-based composite material adhered directly to the tooth surface or a metallic bracket (e.g., stainless steel, Nickel-Titanium, Nickel, ceramics, composites, etc.) attached either directly to the tooth or integrated as part of an oral appliance. The dental anchor may be configured in a shape which corresponds to a shape of channel or groove such that the two may be interfitted in a mating engagement. In this manner, the transducer may vibrate directly against the dental anchor which may then transmit these signals directly into the tooth. Sealing the electronics and/or transducer assembly may facilitate the manufacturing of such devices by utilizing a single size for the electronics encasement which may mount onto a custom-fit retainer or bracket.

[0021] In yet another variation, a bracket may be ferromagnetic or electromagnetic and removably coupled via magnetic attraction to the housing which may also contain a complementary magnetic component for coupling to the magnetic component. The magnetic portion of the bracket may be confined or the entire bracket may be magnetic. One or more alignment members or arms defined along the bracket may facilitate the alignment of the bracket with the housing by aligning with an alignment step.

[0022] Alternative brackets may be configured into a cylindrical configuration sufficiently sized to fit comfortably within the user's mouth. For instance, suitable dimensions for such a bracket may range from 5 to 10 mm in diameter and 10 to 15 mm in length. Alternatively, the bracket may be variously shaped, e.g., ovoid, cubicle, etc. An electronics and/or transducer assembly having an outer surface configured with screw threading may be screwed into the bracket by rotating the assembly into the bracket to achieve a secure attachment for vibrational coupling.

[0023] Other variations utilizing a bracket may define a receiving channel into which the electronics and/or transducer assembly may be positioned and secured via a retaining tab. Yet other variations may utilize a protruding stop member for securing the two components to one another or other mechanical mechanisms for coupling.

[0024] Aside from mechanical coupling mechanisms, chemical attachment may also be utilized. The electronics and/or transducer assembly may be adhered to the bracket via a non-permanent adhesive, e.g., eugenol and non-eugenol cements. Examples

of eugenol temporary cements include, but are not limited to, zinc oxide eugenol commercially available from Temrex (Freeport, NY) or TempoCem® available from Zenith Dental (Englewood, NJ). Other examples of non-eugenol temporary cements include, but are not limited to, cements which are commercially available such as
5 PROVISCELL™ (Septodont, Inc., Ontario, Canada) as well as NOMIX™ (Centrix, Inc., Shelton, CT).

BRIEF DESCRIPTION OF THE DRAWINGS

[0025] Fig. 1 illustrates the dentition of a patient's teeth and one variation of a
10 hearing aid device which is removably placed upon or against the patient's tooth or teeth as a removable oral appliance.

[0026] Fig. 2 illustrates a perspective view of the lower teeth showing one exemplary location for placement of the removable oral appliance hearing aid device.

[0027] Fig. 3 illustrates a partial cross-sectional view of the hearing aid where the
15 electronics and/or transducer assembly may be embedded into the removable custom-made oral appliance.

[0028] Fig. 4 illustrates a schematic representation of one variation of the hearing aid assembly utilizing a receiving transducer which may generally comprise at least one microphone for receiving sounds and which is electrically connected to a processor for
20 processing the auditory signals.

[0029] Fig. 5 illustrates an extra-buccal transmitter assembly located outside the patient's mouth to receive auditory signals for processing and transmitting via a wireless signal to the electronics and/or transducer assembly positioned within the patient's mouth.

[0030] Fig. 6 illustrates a schematic representation of the processor receiving
25 signals via the antenna from external sound-generating devices and controls for modifying various parameters.

[0031] Fig. 7 shows a hearing aid assembly embedded into or configured as a custom made dental implant, e.g., a permanent crown, that may be secured onto an implant post previously implanted into the bone.

- [0032] Fig. 8 shows the electronics and transducer assembly bonded or otherwise adhered directly to the surface of one or more teeth rather than being embedded or attached to a separate housing.
- [0033] Figs. 9A and 9B illustrate perspective and side views, respectively, of an oral appliance which may be coupled to a screw or post implanted directly into the underlying bone, such as the maxillary or mandibular bone.
- [0034] Fig. 10 illustrates another variation in which the oral appliance may be coupled to a screw or post implanted directly into the palate of a patient.
- [0035] Fig. 11 illustrates several screws drilled into several locations within the user's mouth.
- [0036] Fig. 12 shows two components of a partially-removable assembly which are configured to securely mate with one another.
- [0037] Fig. 13A shows yet another variation of an oral appliance having a composite dental anchor for coupling the transducer to the tooth.
- [0038] Fig. 13B illustrates a variation in which the oral appliance may be omitted and the electronics and/or transducer assembly may be attached to a composite dental anchor attached directly to the tooth surface.
- [0039] Fig. 14A shows partial cross-sectional end view of yet another variation where a metallic bracket may be integrated directly with or attached directly to an oral appliance such that the metallic bracket directly contacts the tooth.
- [0040] Fig. 14B illustrates a perspective view of the encasement slidingly removed from the metallic bracket.
- [0041] Fig. 15 illustrates a partial cross-sectional end view of another variation of a system utilizing a bracket mounted to the underlying tooth or teeth.
- [0042] Fig. 16A shows an end view of a bracket containing a magnetic component for removably coupling via magnetic attraction to a housing also containing a complementary magnetic component.
- [0043] Fig. 16B shows an end view of another variation where the entire bracket is magnetic for magnetically coupling to the housing.

- [0044] Fig. 16C shows a top view of yet another variation where a magnetic component may be disposed at a first end of the housing and a complementary magnetic component may be disposed at a first end of the bracket.
- [0045] Figs. 17A and 17B show end and side views, respectively, of a bracket
5 having a cylindrical configuration.
- [0046] Figs. 17C and 17D show assembly side and end views, respectively, of an electronics and/or transducer assembly having a threaded outer surface configured to be screwed into a threaded housing opening of the bracket.
- [0047] Fig. 18A shows an end view of another variation of a bracket which defines
10 a receiving channel into which the electronics and/or transducer assembly may be positioned and secured via retaining tab.
- [0048] Fig. 18B shows a perspective view of the electronics and/or transducer assembly removed from the bracket.
- [0049] Fig. 19A shows a removal tool prior positioned to remove the electronics
15 and/or transducer assembly from the bracket.
- [0050] Figs. 19B and 19C show partial side and top views, respectively, of an engaging step of the removal tool advanced to release the retaining tab from the electronics and/or transducer assembly.
- [0051] Fig. 20A shows an end view of another variation where of a bracket
20 likewise attached to a tooth or teeth.
- [0052] Fig. 20B shows a perspective view of the assembly removed from receiving channel of the bracket.
- [0053] Figs. 21A to 21D illustrate partial cross-sectional side views of one
25 example for the detachment and removal of the electronics and/or transducer assembly from the bracket utilizing a removal tool.
- [0054] Fig. 22A shows an end view of another variation utilizing a bracket and a removable electronics and/or transducer assembly which may be coupled via a sliding mechanism and alignment members protruding from assembly.
- [0055] Figs. 22B and 22C show partial cross-sectional side and end views,
30 respectively, of an assembly positioned partially along the bracket prior to its secure engagement.

[0056] Figs. 23A to 23D illustrate partial cross-sectional side views of an example for engaging and disengaging a removable electronics and/or transducer assembly from its bracket.

[0057] Figs. 24A and 24B illustrate side views of the electronics and/or transducer assembly prior to engagement with a retaining step with the other features removed for clarity to further illustrate the securement mechanism.

[0058] Figs. 25A and 25B show perspective and detail perspective views, respectively, of the electronics and/or transducer assembly retained by an applicator tool for securement into the bracket.

10 [0059] Figs. 25C and 25D show top and end views, respectively, of the assembly and applicator tool illustrating the alignment channels defined along the lengths of the alignment members.

[0060] Figs. 26A and 26B show end views of another coupling mechanism utilizing a chemical attachment.

15 [0061] Fig. 27A illustrates an example where multiple transducer assemblies may be placed on multiple teeth.

[0062] Fig. 27B illustrates another variation where at least one microphone (or optionally any number of additional microphones) may be positioned within the mouth of the user while physically separated from the electronics and/or transducer assembly.

20

DETAILED DESCRIPTION OF THE INVENTION

[0063] An electronic and transducer device may be attached, adhered, or otherwise embedded into or upon a removable oral appliance or other oral device to form a hearing aid assembly. Such an oral appliance may be a custom-made device fabricated from a thermal forming process utilizing a replicate model of a dental structure obtained by conventional dental impression methods. The electronic and transducer assembly may receive incoming sounds either directly or through a receiver to process and amplify the signals and transmit the processed sounds via a vibrating transducer element coupled to a tooth or other bone structure, such as the maxillary, mandibular, or palatine bone structure.

30 [0064] As shown in Fig. 1, a patient's mouth and dentition 10 is illustrated showing one possible location for removably attaching hearing aid assembly 14 upon or

against at least one tooth, such as a molar **12**. The patient's tongue **TG** and palate **PL** are also illustrated for reference. An electronics and/or transducer assembly **16** may be attached, adhered, or otherwise embedded into or upon the assembly **14**, as described below in further detail.

5 **[0065]** Fig. 2 shows a perspective view of the patient's lower dentition illustrating the hearing aid assembly **14** comprising a removable oral appliance **18** and the electronics and/or transducer assembly **16** positioned along a side surface of the assembly **14**. In this variation, oral appliance **18** may be fitted upon two molars **12** within tooth engaging channel **20** defined by oral appliance **18** for stability upon the patient's teeth, although in
10 other variations, a single molar or tooth may be utilized. Alternatively, more than two molars may be utilized for the oral appliance **18** to be attached upon or over. Moreover, electronics and/or transducer assembly **16** is shown positioned upon a side surface of oral appliance **18** such that the assembly **16** is aligned along a buccal surface of the tooth **12**; however, other surfaces such as the lingual surface of the tooth **12** and other positions may
15 also be utilized. The figures are illustrative of variations and are not intended to be limiting; accordingly, other configurations and shapes for oral appliance **18** are intended to be included herein. In one variation, a partial cross-sectional view of the hearing aid assembly **14** is shown in Fig. 3 where the electronics and/or transducer assembly **16** may be embedded into the removable custom-made oral appliance **18**.

20 **[0066]** Generally, the volume of electronics and/or transducer assembly **16** may be minimized so as to be unobtrusive and as comfortable to the user when placed in the mouth. Although the size may be varied, a volume of assembly **16** may be less than 800 cubic millimeters. This volume is, of course, illustrative and not limiting as size and volume of assembly **16** and may be varied accordingly between different users.

25 **[0067]** Moreover, removable oral appliance **18** may be fabricated from various polymeric or a combination of polymeric and metallic materials using any number of methods, such as computer-aided machining processes using computer numerical control (CNC) systems or three-dimensional printing processes, e.g., stereolithography apparatus (SLA), selective laser sintering (SLS), and/or other similar processes utilizing three-
30 dimensional geometry of the patient's dentition, which may be obtained via any number of techniques. Such techniques may include use of scanned dentition using intra-oral

scanners such as laser, white light, ultrasound, mechanical three-dimensional touch scanners, magnetic resonance imaging (MRI), computed tomography (CT), other optical methods, etc.

5 [0068] In forming the removable oral appliance 18, the appliance 18 may be optionally formed such that it is molded to fit over the dentition and at least a portion of the adjacent gingival tissue to inhibit the entry of food, fluids, and other debris into the oral appliance 18 and between the transducer assembly and tooth surface. Moreover, the greater surface area of the oral appliance 18 may facilitate the placement and configuration of the assembly 16 onto the appliance 18.

10 [0069] Additionally, the removable oral appliance 18 may be optionally fabricated to have a shrinkage factor such that when placed onto the dentition, oral appliance 18 may be configured to securely grab onto the tooth or teeth as the appliance 18 may have a resulting size slightly smaller than the scanned tooth or teeth upon which the appliance 18 was formed. The fitting may result in a secure interference fit between the appliance 18 and underlying dentition.

15 [0070] Fig. 4 illustrates a schematic representation of one variation of hearing aid assembly 14 utilizing receiving transducer 30, which may generally comprise microphone for receiving sounds and which is electrically connected to processor 32 for processing the auditory signals. Processor 32 may be electrically connected to antenna 34 for receiving
20 wireless communication signals, e.g., input control signals from an external remote control 36 and/or other external sound generating devices, e.g., cell phones, telephones, stereos, MP3 players, and other media players. The microphone 30 and processor 32 may be configured to detect and process auditory signals in any practicable range, but may be configured in one variation to detect auditory signals ranging from, e.g., 250 Hertz to
25 20,000 Hertz. The detected and processed signals may be amplified via amplifier 44, which increases the output levels for vibrational transmission by transducer 40 into the adjacent, or otherwise coupled, bone structure such as a patient's tooth or teeth 12.

[0071] With respect to microphone 30, a variety of various microphone systems may be utilized. For instance, microphone 30 may be a digital, analog, piezo, and/or
30 directional type microphone. Such various types of microphones may be interchangeably configured to be utilized with the assembly, if so desired.

[0072] Power supply **42** may be connected to each of the components such as processor **32** and transducer **40** to provide power thereto. The control or other sound generated signals received by antenna **34** may be in any wireless form utilizing, e.g., radio frequency, ultrasound, microwave, Blue Tooth® (BLUETOOTH SIG, INC., Bellevue, WA), etc. for transmission to assembly **16**. The external remote control **36** may be utilized such that a user may manipulate to adjust various acoustic parameters of the electronics and/or transducer assembly **16**, such as acoustic focusing, volume control, filtration, muting, frequency optimization, sound adjustments, and tone adjustments, etc.

[0073] The signals transmitted may be received by electronics and/or transducer assembly **16** via a receiver, which may be connected to an internal processor for additional processing of the received signals. The received signals may be communicated to transducer **40**, which may vibrate correspondingly against a surface of the tooth to conduct the vibratory signals through the tooth and bone and subsequently to the middle ear to facilitate hearing of the user. Transducer **40** may be configured as any number of different vibratory mechanisms. For instance, in one variation, transducer **40** may be an electromagnetically actuated transducer. In other variations, transducer **40** may be in the form of a piezoelectric crystal having a range of vibratory frequencies, e.g., between 250 to 20,000 Hz.

[0074] Although power supply **42** may be a simple battery, replaceable or permanent, other variations may include a power supply **42** which is charged by inductance via an external charger. Additionally, power supply **42** may alternatively be charged via direct coupling **48** to an alternating current (AC) or direct current (DC) source. Other variations may include a power supply **42** which is charged via a mechanical mechanism **46**, such as an internal pendulum or slidable electrical inductance charger as known in the art, which is actuated via, e.g., motions of the jaw and/or movement for translating the mechanical motion into stored electrical energy for charging power supply **42**.

[0075] In one variation, with assembly **14** positioned upon the teeth, as shown in Fig. 5, an extra-buccal transmitter assembly **22** located outside the patient's mouth may be utilized to receive auditory signals for processing and transmission via a wireless signal **24** to the electronics and/or transducer assembly **16** positioned within the patient's mouth,

which may then process and transmit the processed auditory signals via vibratory conductance to the underlying tooth and consequently to the patient's inner ear.

[0076] The transmitter assembly **22**, as described in further detail below, may contain a microphone assembly as well as a transmitter assembly and may be configured
5 in any number of shapes and forms worn by the user, such as a watch, necklace, lapel, phone, belt-mounted device, etc.

[0077] In such a variation, as illustrated schematically in Fig. 6, the processor **32** may receive the signals through antenna **34** from external sound-generating devices **38** (as
10 described above, e.g., cell phones, telephones, stereos, MP3 players, and other media players) as well as from other incoming sounds received from receiving transducer **30** for processing and transmission to the hearing aid assembly **14**. Control **36** may be used to modify various parameters of the received sound while powered by battery **42**, as above.

[0078] In another variation, a hearing aid assembly may be embedded into or configured as a custom made dental implant **54** (e.g., a permanent crown) that may be
15 secured onto an implant post **50** previously implanted into the bone **52**, e.g., jaw bone, of a patient, as shown in Fig. 7. Dental implant **54** may be secured or coupled to post **50** via receiving channel **56** defined within implant **54**. The transducer assembly as well as the associated electronics and power supply may be contained within implant **54** such that
20 when implant **54** received a signal for conductance to the user, the transducer may vibrate within implant **54** to conduct the vibrations through post **50** and into the user.

[0079] In yet another variation, the electronics and transducer assembly **16** may be bonded or otherwise adhered directly to the surface of one or more teeth **12** rather than embedded or attached to a separate housing, as shown in Fig. 8.

[0080] In yet other variations, vibrations may be transmitted directly into the
25 underlying bone or tissue structures rather than transmitting directly through the tooth or teeth of the user. As shown in Fig. 9A, an oral appliance **70** is illustrated positioned upon the user's tooth, in this example upon a molar located along the upper row of teeth. The electronics and/or transducer assembly **72** is shown as being located along the buccal surface of the tooth. Rather than utilizing a transducer in contact with the tooth surface, a
30 conduction transmission member **74**, such as a rigid or solid metallic member, may be coupled to the transducer in assembly **72** and extend from oral appliance **70** to a post or

screw 76 which is implanted directly into the underlying bone 78, such as the maxillary bone, as shown in the partial cross-sectional view of Fig. 9B. As the distal end of transmission member 74 is coupled directly to post or screw 76, the vibrations generated by the transducer may be transmitted through transmission member 74 and directly into post or screw 76, which in turn transmits the vibrations directly into and through the bone 78 for transmission to the user's inner ear.

[0081] Fig. 10 illustrates a partial cross-sectional view of an oral appliance 80 placed upon the user's tooth TH with the electronics and/or transducer assembly 82 located along the lingual surface of the tooth. Similarly, the vibrations may be transmitted through the conduction transmission member 74 and directly into post or screw 76, which in this example is implanted into the palatine bone PL. Other variations may utilize this arrangement located along the lower row of teeth for transmission to a post or screw 76 drilled into the mandibular bone. In yet other variations, one or more screws may be drilled into several locations within the user's mouth. For instance, two screws 60, 62 may be drilled along the maxillary and palatine bone, as shown in Fig. 11.

[0082] Additional examples of various transducer configurations and elements which may be utilized with any of the configurations described herein, as practicable, are shown and described in further detail in U.S. Pat. App. Serial No. 11/741,648 filed April 27, 2007, which is incorporated herein by reference in its entirety.

[0083] In other variations utilizing multiple components, generally a first component may be attached to the tooth or teeth using permanent or semi-permanent adhesives while a second removable component may be attached, adhered, or otherwise affixed to the first component. Examples of adhesives for attaching the first component to the tooth or teeth may include cements and epoxies intended to be applied and/or removed by a healthcare provider. Examples of typical dental cements include, but are not limited to, zinc oxide eugenol, zinc phosphate, zinc silico-phosphate, zinc-polyacrylate, zinc-polycarboxylate, glass ionomer, resin-based, silicate-based cements, etc.

[0084] The first component can contain any, all, or none of the mechanisms and/or electronics (e.g., actuators, processors, receivers, etc.) while the second component, which can be attached to the first component, can also contain any combination of the mechanisms and/or electronics, such as the battery. These two components may be

temporarily coupled utilizing a variety of mechanisms, e.g., electromagnetic, mechanical attachment, chemical attachment, or a combination of any or all of these coupling mechanisms.

5 [0085] An illustrative example is shown in Fig. 12, which shows two components of assembly **84** which are configured to securely mate with one another. A first component **86** may be permanently or non-removably attached onto the underlying tooth or teeth **TH** and a second component **88** may be removably coupled to the first component **86** by the user. First component **86** may be bonded, adhered, or otherwise affixed via an attachment mechanism **89** such as a cement, epoxy, glue, etc., as mentioned above.

10 [0086] In one variation, the first component **86** may contain a signal processor, transducer, receiver, and any combinations of these components or including additional components. In another variation, the first component may omit each of these elements and function simply as an attachment base for holding and securing the components relative to the tooth. In either case, the second component **88** may comprise a power supply alone, such as a battery, if the remaining components are contained within first component **86** or it may optionally comprise a power supply in combination with a processor, transducer, receiver, etc. Moreover, first and second components **86**, **88** may be coupled to one another via any number of magnetic, mechanical, or chemical attachment mechanisms, which are described below in further detail.

20 [0087] In another variation, an electronics and/or transducer assembly **90** may define a channel or groove **92** along a surface for engaging a corresponding dental anchor or bracket **96**, as shown in Fig. 13A. Dental anchor **96** may comprise a light-curable acrylate-based composite material adhered directly to the tooth surface. Moreover dental anchor **96** may be configured in a shape which corresponds to a shape of channel or groove **92** such that the two may be interfitted in a mating engagement. In this manner, the transducer in assembly **90** may vibrate directly against dental anchor **96** which may then transmit these signals directly into the tooth **TH**. Sealing the electronics and/or transducer assembly **90** may facilitate the manufacturing of such devices by utilizing a single size for the electronics encasement which may mount onto a custom-fit retainer or bracket.

30

[0088] Fig. 13B shows yet another variation in which the oral appliance is omitted entirely. Here, a composite dental anchor or bracket **96** may be adhered directly onto the tooth surface, as above. Alternatively, bracket **96** may be comprised of a biocompatible material, e.g., stainless steel, Nickel-Titanium, ceramics, composites, etc., formed into a bracket and anchored onto the tooth surface. The bracket **96** may be configured to have a shape **98** over which an electronics and/or transducer assembly **90** may be slid over or upon via a channel **92** having a corresponding receiving configuration **94** for engagement with bracket **96**. In this manner, assembly **90** may be directly engaged against bracket **96**, through which a transducer may directly vibrate into the underlying tooth **TH**.

5

10 Additionally, in the event that assembly **90** is removed from the tooth **TH**, assembly **90** may be simply slid or rotated off bracket **96** and a replacement assembly may be put in its place upon bracket **96**.

[0089] Fig. 14A shows yet another variation where a metallic bracket **100**, fabricated from any of the metals or composites mentioned above, may be integrated directly with or attached directly to oral appliance **18** such that metallic bracket **100** directly contacts tooth **TH** via an inner contact surface **102** to facilitate coupling and transmission of the vibrations. As also described above, the removable encasement **106** may contain the transducer and many of the electronics, e.g., power supply, receiver, processor, etc., in an enclosure which is hermetically sealed. As above, metallic bracket

15

20 **100** may have one or more retaining or alignment members **104** which are configured to slidingly or rotatingly mate with a complementary retaining channel **114** defined within encasement **106**. Also illustrated is an example of positioning of transducer assembly **108**, which may contact against metallic bracket **100** when mated, as well as receiver/processor **110** and power supply or battery **112**. To remove encasement **106** and transducer

25 assembly **108** from metallic bracket **100**, encasement **106** may be slid off bracket **100** or oral appliance **18** may be removed entirely from user's tooth or teeth **TH**. Fig. 14B illustrates a perspective view of encasement **106** slidingly removed from metallic bracket **100**.

[0090] Fig. 15 illustrates a partial cross-sectional end view of another variation of a system utilizing a bracket **120** fabricated from any of the materials described above and mounted to the underlying tooth or teeth **TH**. This variation may utilize bracket **120**

30

attached or otherwise affixed against mounting surface **122**. Bracket **120** may define one or more mounting members or surfaces **124** upon which housing **126** may be secured via one or more securement members **128** extending from housing **126** to grasp or mechanically lock onto mounting members or surfaces **124**. The one or more securement members **128** may be fabricated from a metallic or plastic member such as a clip or soft rubber boot.

[0091] Housing **126** not only provides mass for enhancing the vibrational transmission, but it also encapsulates the removable electronics and actuators, etc. An alignment member or feature **130** (e.g., a rod, dowel, or cylindrical projection which aligns the coil **132** with magnet **138**) may be configured as a weak magnet poled in such a direction that its field interacts with the permanent magnet **138** to guide the motion of the transducer against bracket **120**. In this variation, coil **132** may be wound about bobbin **134**, which may be mounted against mounting substrate or surface **136** contained within housing **126**. Coil **132** may interact with an adjacent permanent magnet **138** which vibrates against bracket **120**. Moreover, coil **132** may be connected via electrical connector **142** leading to electronics **140**. Power supply **144** may also be in electrical communication with the various elements contained within housing **126**.

[0092] In yet another variation, Fig. 16A shows an end view of bracket **160** which may contain magnetic component **166**, which may be ferromagnetic or electromagnetic, for removably coupling via magnetic attraction to housing **162** which may also contain a complementary magnetic component **168** for coupling to magnetic component **166**. One or more alignment members or arms **164** defined along bracket **160** may facilitate the alignment of bracket **160** with housing **162** by aligning with alignment step **170**. Fig. 16B shows another variation where bracket **160** may be configured such that the entire bracket is magnetic **172** for magnetically coupling to housing **162**.

[0093] Fig. 16C shows yet another variation where a magnetic component **174** may be disposed at a first end of housing **162** and a complementary magnetic component **176** may be disposed at a first end of bracket **160**. Having the magnetic components disposed along a single portion of bracket **160** and housing **162** may help to align housing **168** in a desired orientation when sliding housing **168** upon bracket **160**.

[0094] Another variation is illustrated in the end and side views of Figs. 17A and 17B, which show bracket **180** configured into a cylindrical configuration. Cylindrical bracket **180** may be adhered to attached to tooth **TH** via attachment **184** and is sufficiently sized to fit comfortably within the user's mouth. For instance, suitable dimensions for
5 bracket **180** may range from 5 to 10 mm in diameter and 10 to 15 mm in length. Although illustrated in a cylindrical configuration, bracket **180** may be variously shaped, e.g., ovoid, cubicle, etc.

[0095] An electronics and/or transducer assembly **182** having an outer surface configured with screw threading **190** may be screwed into threaded housing opening **188**
10 of bracket **180**, as shown in the assembly side view of Fig. 17C. By rotating assembly **182** into bracket **180**, e.g., by utilizing screw guide **186** as shown in Fig. 17D, a secure attachment and vibrational coupling may be achieved. Housing **180** may be removed from bracket **180** by reversing the direction of rotation of housing **180**.

[0096] Fig. 18A shows an end view of another variation utilizing bracket **200**
15 attached to tooth **TH** via attachment **204** and which defines a receiving channel **208** into which electronics and/or transducer assembly **202** may be positioned and secured via retaining tab **206**. As shown in Fig. 18B, a perspective view of the assembly with assembly **202** removed from bracket **200** illustrates the housing of assembly **202** defining one or more tool alignment grooves **210** along one or both sides of the housing. A tool
20 opening **216** is defined along a proximal end of the housing and opens into a removal tool channel **214** defined through the length of assembly **202**. Moreover, retaining tab receiving opening **212** is also defined near or at a distal end of the housing for receiving the retaining tab **206** when assembly **202** is inserted within bracket **200**.

[0097] As shown in Fig. 19A, assembly **202** has been slid within bracket **200** and
25 retaining tab **206** has been engaged within tab receiving opening **212**. To remove assembly **202** from bracket **200**, removal tool **220** may be used to release and remove assembly **202**. Removal tool **220** may comprise central member **222** extending from elongate member **228**. An engaging step **224** may be defined near or at a distal end of central member **222** for releasing tab **206** and two tool alignment members or prongs **226**
30 may also extend from elongate member **228** in parallel on either side of central member **222**.

[0098] During removal, engaging step **224** and central member **222** may be inserted into opening **216**. With alignment members **226** slid into their respective alignment grooves defined along either side of assembly **202**, engaging step **224** may be advanced until a distal portion of central member **222** releases tab **206** from tab receiving opening **212**, as shown in the partial cross-sectional side view of Fig. 19B. With tab **206** disengaged, engaging step **224** may catch upon the edge of opening **212**, as shown in Fig. 19B and the top view of Fig. 19C, allowing central member **222** and step **224** to pull assembly **202** from bracket **200** for removal.

[0099] Fig. 20A shows an end view of another variation where bracket **230** may likewise be attached to tooth or teeth **TH** via attachment **234** and contain electronics and/or transducer assembly **232** within. Although illustrated as having an oval shape, any number of configurations may be utilized. Fig. 20B shows a perspective view of assembly **232** removed from receiving channel **238** of bracket **230**. Assembly **232** may define a removal tool opening **242** at a proximal end and a protruding stop **240**, e.g., ball, spring, etc., which may project at least partially from a surface of assembly **232**. Bracket **230** may define a stop engagement opening **236** near or at a distal end of the bracket **230** such that when assembly **232** is initially inserted within bracket **230**, stop **240** may be depressed into assembly **232** until released into stop engagement opening **236**, thus functioning as a locking mechanism for retaining assembly **232** within bracket **230**.

[0100] To remove assembly **232** from bracket **230**, an elongate removal tool **256** having a step **258** defined near or at a distal end of tool **256** may be inserted into removal tool receiving channel **252** defined within assembly **242**, as illustrated in Fig. 21A. Tool **256** may be advanced through channel **252** until it contacts stop **240**, illustrated here as a spherical ball protruding through engagement opening **236** of bracket **230**, as shown in Fig. 21B. Step **258** may be urged distally to push stop **240** out of engagement with opening **236** until tool **256** has been pushed over stop **240** to release assembly **232** from bracket **230**. With stop **240** compressed against biasing element **250**, e.g., a spring, tool **256** may be further advanced until step **258** engages engagement step **254**, which is defined at the end of tool receiving channel **252**, as shown in Fig. 21C. With tool **256** engaged via step **258** to engagement step **254**, assembly **232** may then be slid proximally out from bracket **230** for removal, as shown in Fig. 21D.

[0101] Fig. 22A shows an end view of another variation utilizing bracket **260** and removable electronics and/or transducer assembly **262** which may be coupled via a sliding mechanism and alignment members **264** protruding from assembly **262**. Figs. 22B and 22C show partial cross-sectional side and end views, respectively, of assembly **262** positioned partially along bracket **260** prior to secure engagement. Assembly **262** may define alignment members **264** protruding from either side of the housing and tool applicator rails **268**, as described in further detail below, also protruding from either side of the housing along the length of assembly **262**. A distal end of assembly **262** also defines a stop member **270** protruding from the housing for engagement with bracket **260**. Bracket **260** defines one or more sliding tracks **266** along a length of bracket **260** through which the alignment members **264** may be inserted and guided through. Tracks **266** may further define a curved portion **278** along a distal end of sliding track **266**, as described further below. A distal end of bracket **260** also defines a retaining step **272** for engagement with stop member **270** of assembly **262**. A biasing element **276**, e.g., a spring, may also be positioned within a cavity **274** defined near or at a distal portion of bracket **260**.

[0102] In use, when assembly **262** is to be coupled to bracket **260**, alignment members **264** may be inserted into a proximal end of sliding track **266** and advanced therealong, as shown in Figs. 23A and 23B. Assembly **262** may be urged distally until it contacts biasing element **276** contained within the distal portion of bracket **260** whereupon assembly **262** may be further urged distally while compressing biasing element **276**. Sliding track **266** may be curved in such a manner where further advancement of assembly **262** forces stop member **270** to become engaged against retaining step **272**. With the compressed biasing element **276** pushing against assembly **262**, stop member **270** may be secured against retaining step **272** to inhibit or prevent the release of assembly **262**, as shown in Fig. 23C. To release assembly **262** from bracket **260**, assembly **262** may be pushed further distally relative to bracket **260** to further compress biasing element **276**. With the distal portion **278** of sliding track **266** curved transversely relative to the proximal portion of track **266**, alignment members **264** may be slid through the distal portion **278** and released from bracket **260** for removal, as shown in Fig. 23D.

[0103] Figs. 24A and 24B show side views of the assembly 262 prior to engagement with retaining step 272 with the other features removed for clarity to further illustrate the securement mechanism. As shown, as assembly 262 contacts and compresses biasing element 276, stop member 270 is eventually brought into engagement with retaining step 272 for securing assembly 262 to bracket 260.

[0104] In order to facilitate the handling and introduction of assembly 262 into engagement with bracket 260, applicator tool 280 may be used, as shown in the perspective assembly view of Fig. 25A, to insert and secure assembly 262 relative to bracket 260. Tool 280 may define two alignment members 282, 284 which extend distally for releasably holding assembly 262 on either side. As seen in the detail perspective view of Fig. 25B, applicator rails 268 protruding from either or both sides of assembly 262 along the length of the housing may be slid into corresponding alignment channels 286 which are defined along the length of alignment members 282, 284 such that the applicator rails 268 are secured and transverse movement of assembly 262 relative to alignment members 282, 284 is inhibited or prevented, as shown in the top and end views of Figs. 25C and 25D, respectively.

[0105] Aside from mechanical coupling mechanisms, chemical attachment may also be utilized. As shown in the end views of Figs. 26A and 26B, electronics and/or transducer assembly 292 may be adhered to bracket 290 via a non-permanent adhesive 294. Examples of such temporary adhesive 294 may include, e.g., eugenol and non-eugenol cements. Examples of eugenol temporary cements include, but are not limited to, zinc oxide eugenol commercially available from Temrex (Freeport, NY) or TempoCem® available from Zenith Dental (Englewood, NJ). Other examples of non-eugenol temporary cements include, but are not limited to, cements which are commercially available such as PROVISCCELL™ (Septodont, Inc., Ontario, Canada) as well as NOMIX™ (Centrix, Inc., Shelton, CT).

[0106] For any of the variations described above, they may be utilized as a single device or in combination with any other variation herein, as practicable, to achieve the desired hearing level in the user. Moreover, more than one oral appliance device and electronics and/or transducer assemblies may be utilized at any one time. For example, Fig. 27A illustrates one example where multiple transducer assemblies 300, 302, 304, 306

may be placed on multiple teeth. Although shown on the lower row of teeth, multiple assemblies may alternatively be positioned and located along the upper row of teeth or both rows as well. Moreover, each of the assemblies may be configured to transmit vibrations within a uniform frequency range. Alternatively in other variations, different
5 assemblies may be configured to vibrate within non-overlapping frequency ranges between each assembly. As mentioned above, each transducer **300**, **302**, **304**, **306** can be programmed or preset for a different frequency response such that each transducer may be optimized for a different frequency response and/or transmission to deliver a relatively high-fidelity sound to the user.

10 **[0107]** Moreover, each of the different transducers **300**, **302**, **304**, **306** can also be programmed to vibrate in a manner which indicates the directionality of sound received by the microphone worn by the user. For example, different transducers positioned at different locations within the user's mouth can vibrate in a specified manner by providing sound or vibrational queues to inform the user which direction a sound was detected
15 relative to an orientation of the user. For instance, a first transducer located, e.g., on a user's left tooth, can be programmed to vibrate for sound detected originating from the user's left side. Similarly, a second transducer located, e.g., on a user's right tooth, can be programmed to vibrate for sound detected originating from the user's right side. Other variations and queues may be utilized as these examples are intended to be illustrative of
20 potential variations.

[0108] In yet another variation for separating the microphone from the transducer assembly, Fig. 27B illustrates another variation where at least one microphone **312** (or optionally any number of additional microphones **314**, **316**) may be positioned within the mouth of the user while physically separated from the electronics and/or transducer
25 assembly **310**. In this manner, the one or optionally more microphones **312**, **314**, **316** may be wirelessly coupled to the electronics and/or transducer assembly **310** in a manner which attenuates or eliminates feedback from the transducer.

[0109] Further examples of these algorithms are shown and described in detail in U.S. Pat. App. Serial Nos. 11/672,239; 11/672,250; 11/672,264; and 11/672,271 all filed
30 February 7, 2007 and each of which is incorporated herein by reference in its entirety.

[0110] The applications of the devices and methods discussed above are not limited to the treatment of hearing loss but may include any number of further treatment applications. Moreover, such devices and methods may be applied to other treatment sites within the body. Modification of the above-described assemblies and methods for carrying out the invention, combinations between different variations as practicable, and variations of aspects of the invention that are obvious to those of skill in the art are intended to be within the scope of the claims.

CLAIMS

What is claimed is:

1. An apparatus for transmitting vibrations via at least one tooth to facilitate hearing in a patient, comprising:
 - 5 a bracket affixed to a surface of the at least one tooth; and
 - a housing assembly removably coupled to the bracket such that an actuatable transducer is placed in vibratory communication with the bracket and wherein the transducer conducts vibrations directly into the surface via the bracket.
- 10 2. The apparatus of claim 1 wherein the bracket is affixed to the surface via an adhesive or cement.
3. The apparatus of claim 2 wherein the adhesive or cement is selected from the group consisting of zinc oxide eugenol, zinc phosphate, zinc silico-phosphate, zinc-
 - 15 polyacrylate, zinc-polycarboxylate, glass ionomer, resin-based, and silicate-based cements.
4. The apparatus of claim 1 wherein the bracket defines one or more projections configured to securely mate with the housing assembly so as to inhibit or prevent
20 disconnection of the housing assembly when coupled to one another.
5. The apparatus of claim 1 wherein the bracket comprises a rail upon which the housing assembly slides.
- 25 6. The apparatus of claim 1 wherein the bracket assembly is integrated with an oral appliance which is configured to be placed upon and conform to the at least one tooth.
7. The apparatus of claim 1 wherein the bracket comprises a magnetic portion which is configured to couple to a complementary magnetic portion contained within the
30 housing assembly.

8. The apparatus of claim 1 wherein the bracket comprises a cylindrical housing configured to receive the housing assembly having a threaded outer surface.
9. The apparatus of claim 1 wherein the bracket comprises a releasable retaining
5 tab configured to engage an opening along the housing assembly.
10. The apparatus of claim 1 wherein the bracket defines an opening configured to receive a protruding stop projecting from the housing assembly.
- 10 11. The apparatus of claim 1 wherein the bracket comprises a biasing element configured to urge the housing assembly into a secure engagement via a retaining step.
12. The apparatus of claim 1 wherein the bracket and housing assembly are coupled via a temporary adhesive or cement.
15
13. The apparatus of claim 1 wherein the housing assembly comprises a processor in communication with the actuatable transducer.
14. The apparatus of claim 13 further comprising a battery contained within the
20 housing assembly.
15. The apparatus of claim 1 wherein the housing assembly comprises an alignment member configured to align the housing relative to the bracket.
- 25 16. The apparatus of claim 1 further comprising an alignment tool having at least two members projecting distally, wherein the two members each define an alignment channel for slidably receiving the housing assembly.
17. The apparatus of claim 1 further comprising at least one additional actuatable
30 transducer in vibratory communication with the surface.

18. The apparatus of claim 17 wherein the at least one additional actuatable transducer is disposed within or upon at least one additional bracket affixed to a surface of an additional tooth.

5 19. The apparatus of claim 17 wherein each transducer is configured to provide a sound or vibrational cue indicative of a direction in which sound is detected relative to an orientation of a user.

10 20. A method of transmitting vibrations via at least one tooth, comprising:
affixing a bracket onto a surface of the at least one tooth;
coupling a removable housing assembly onto the bracket; and
actuating a transducer within the housing assembly which is in vibratory communication with the bracket such that the transducer conducts vibrations directly into the surface via the bracket.

15 21. The method of claim 20 wherein affixing comprises adhering the bracket onto the surface via an adhesive or cement.

20 22. The method of claim 21 wherein adhering comprises permanently adhering the bracket onto the surface.

 23. The method of claim 20 wherein coupling comprises magnetically coupling the housing assembly onto the bracket.

25 24. The method of claim 20 wherein coupling comprises sliding the housing assembly upon a rail defined along the bracket.

 25. The method of claim 20 wherein coupling comprises screwing the housing assembly into a threaded receiving channel of the bracket.

30

26. The method of claim 20 wherein coupling further comprises securing the housing assembly to the bracket via a locking tab.

5 27. The method of claim 20 wherein coupling further comprises securing the housing assembly to the bracket via a stop member protruding from the housing assembly into the bracket.

10 28. The method of claim 20 wherein coupling further comprises securing the housing assembly to the bracket via a biasing element compressing a retaining step between the housing assembly and the bracket.

29. The method of claim 20 wherein coupling comprises positioning the housing assembly onto the bracket via an alignment tool.

15 30. The method of claim 20 wherein coupling comprises adhering the housing assembly to the bracket via a temporary adhesive or cement.

20 31. The method of claim 20 further comprising receiving an electronic signal representative of a received audio signal prior to actuating a transducer.

32. The method of claim 31 wherein receiving further comprises processing the electronic signal via a processor.

25 33. The method of claim 20 wherein actuating comprises actuating the transducer to correspond to a perceived audio signal.

30 34. The method of claim 20 further comprising actuating at least one additional transducer in vibratory communication with at least one additional bracket affixed upon an additional tooth.

35. The method of claim 20 further comprising removing the housing assembly from the bracket.

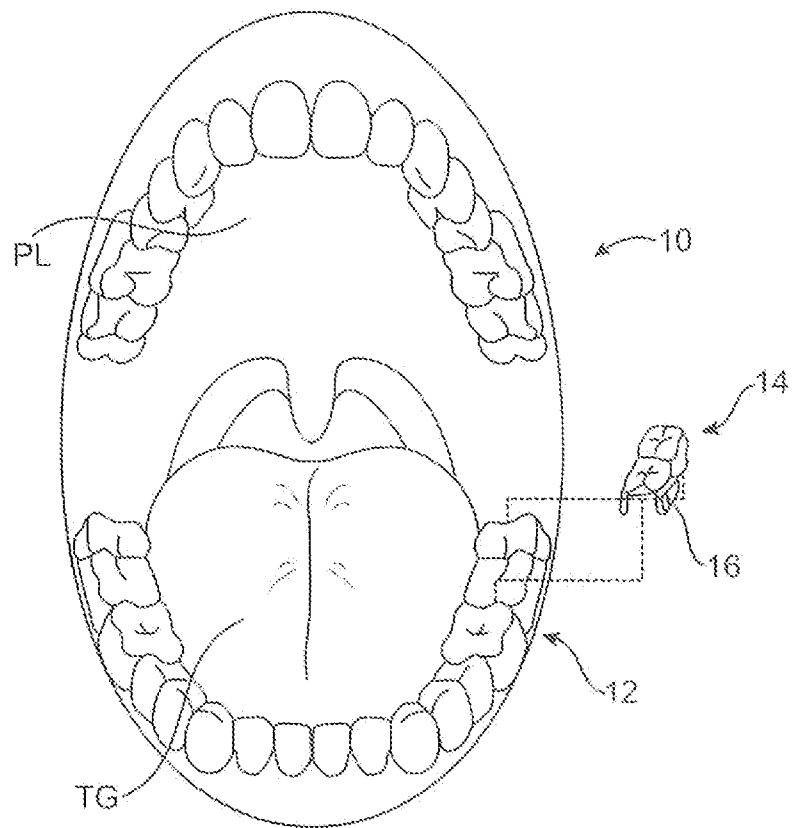

FIG. 1

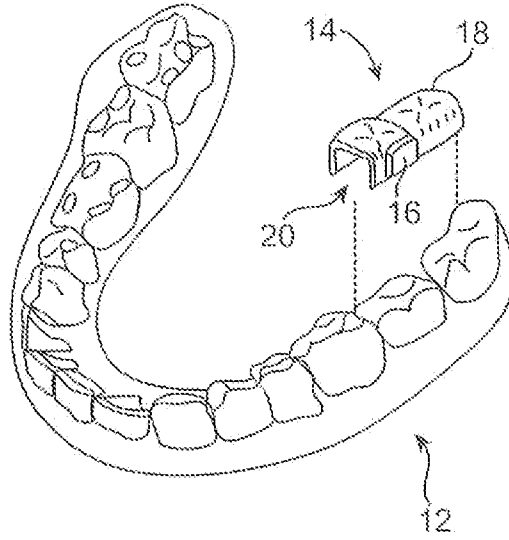

FIG. 2

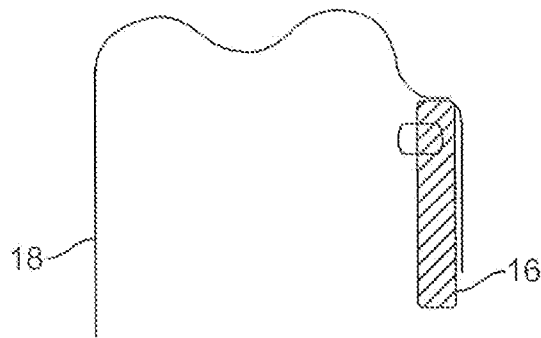

FIG. 3

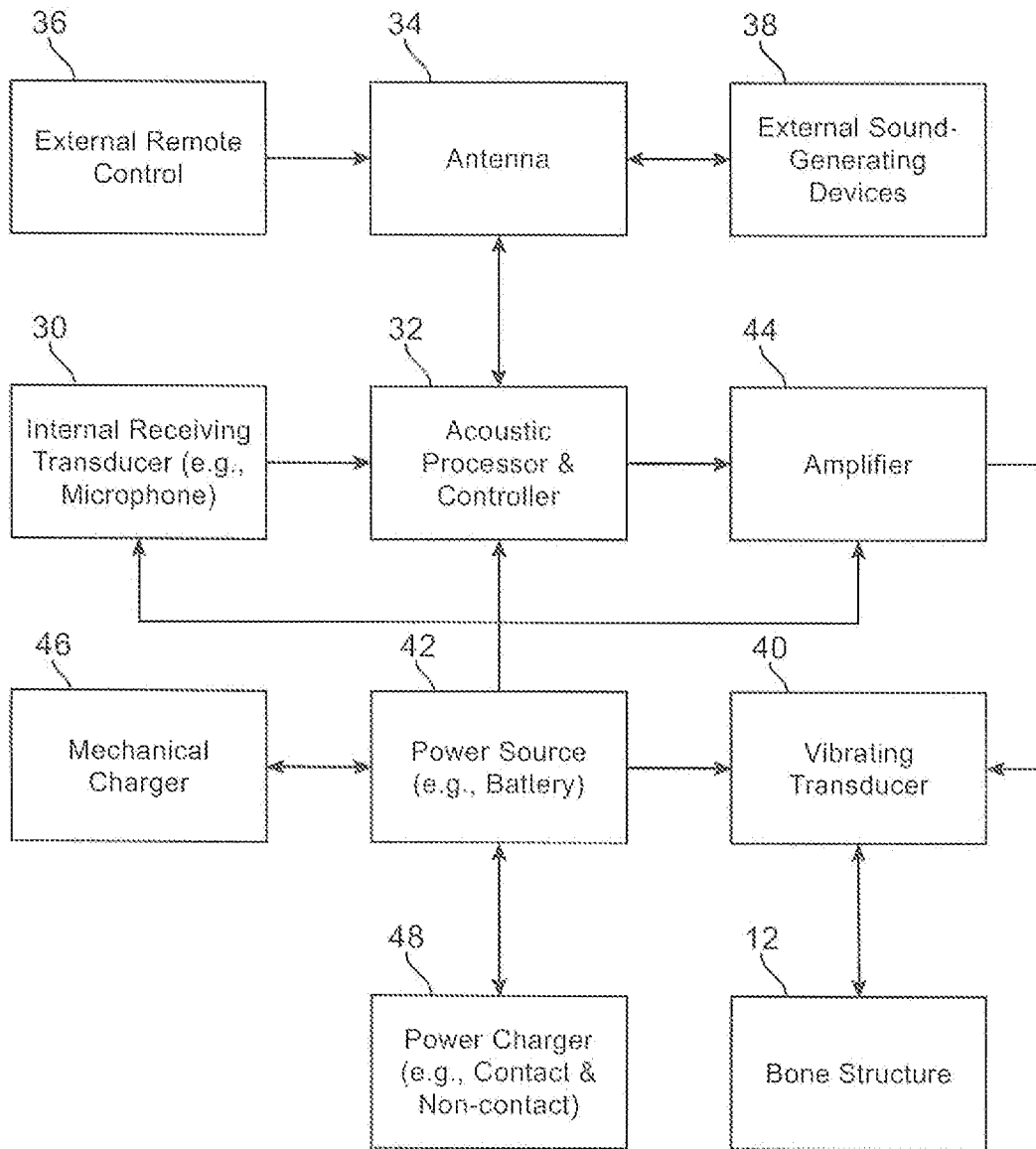

FIG. 4

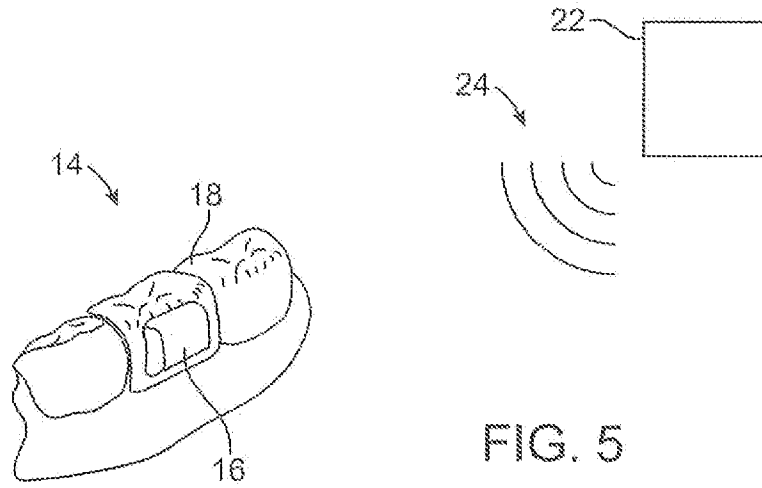

FIG. 5

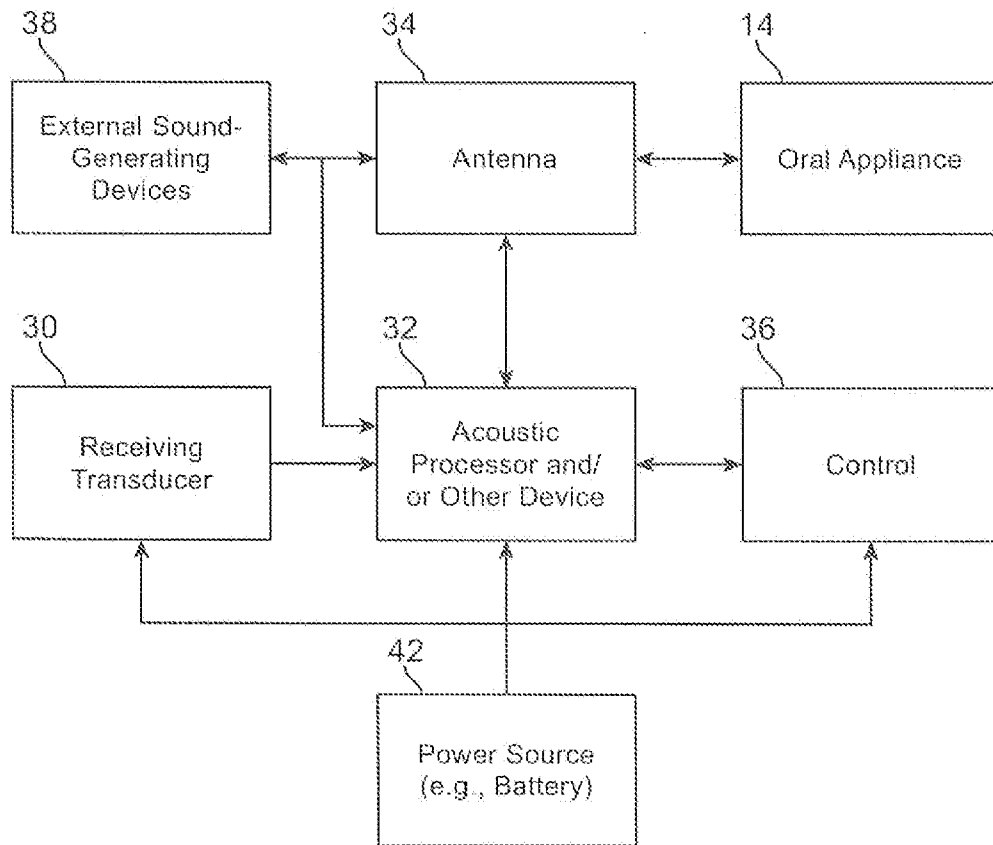

FIG. 6

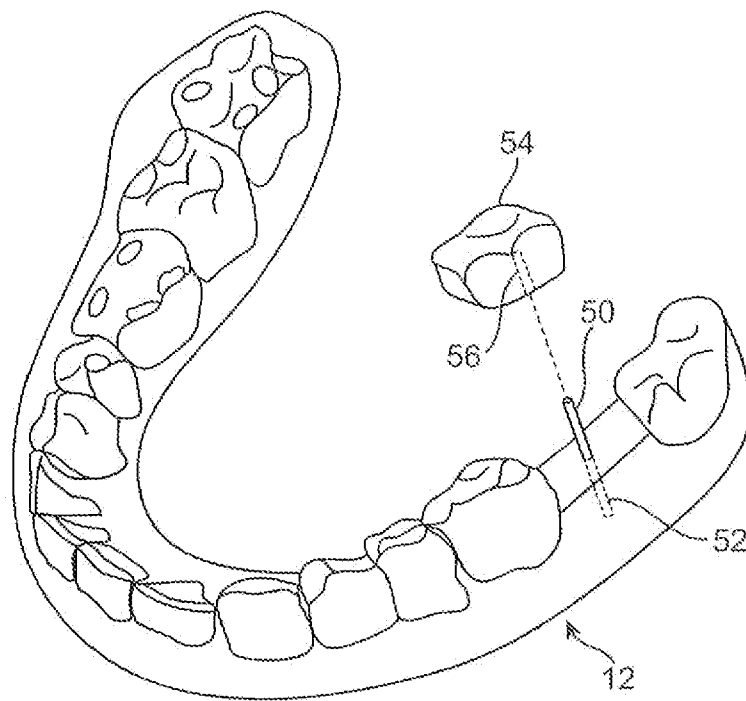

FIG. 7

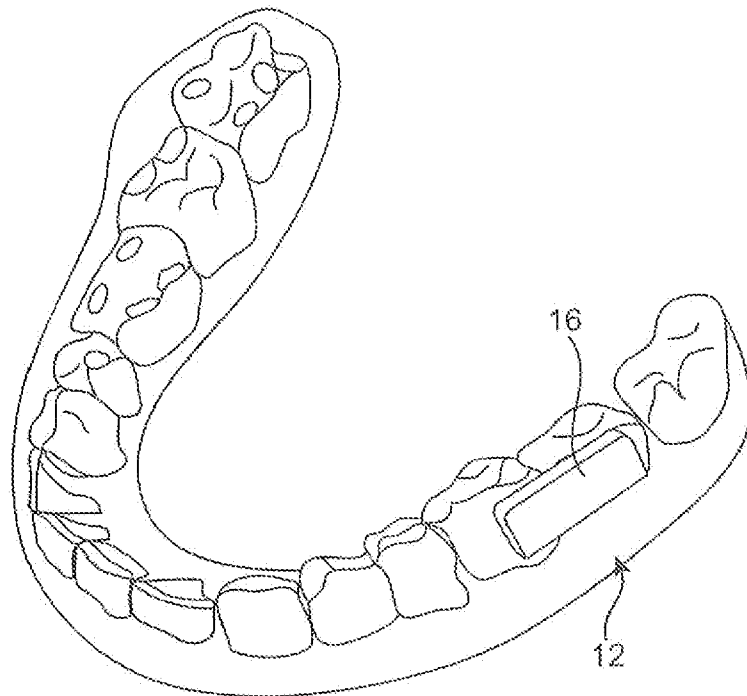

FIG. 8

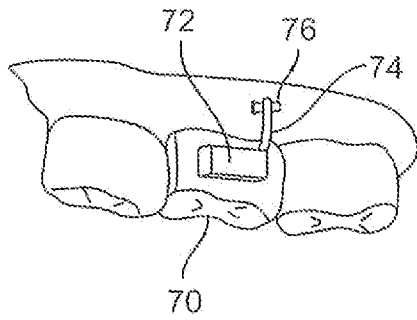

FIG. 9A

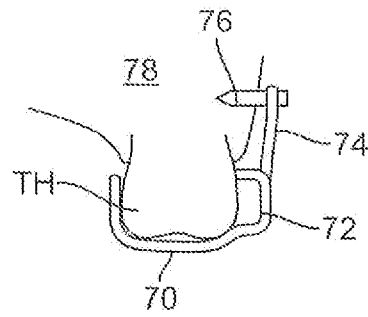

FIG. 9B

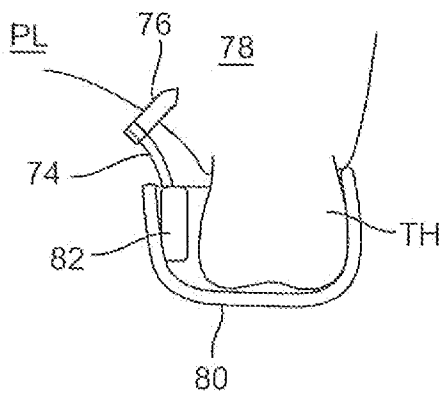

FIG. 10

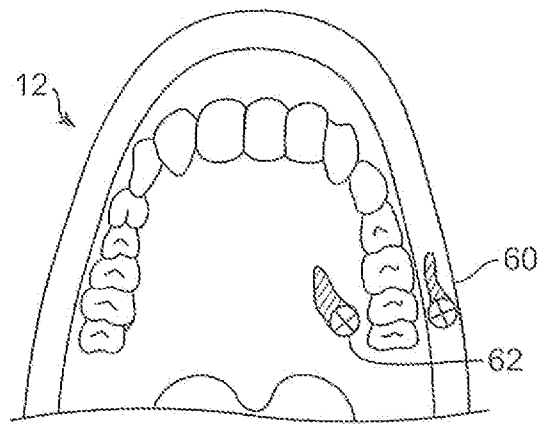

FIG. 11

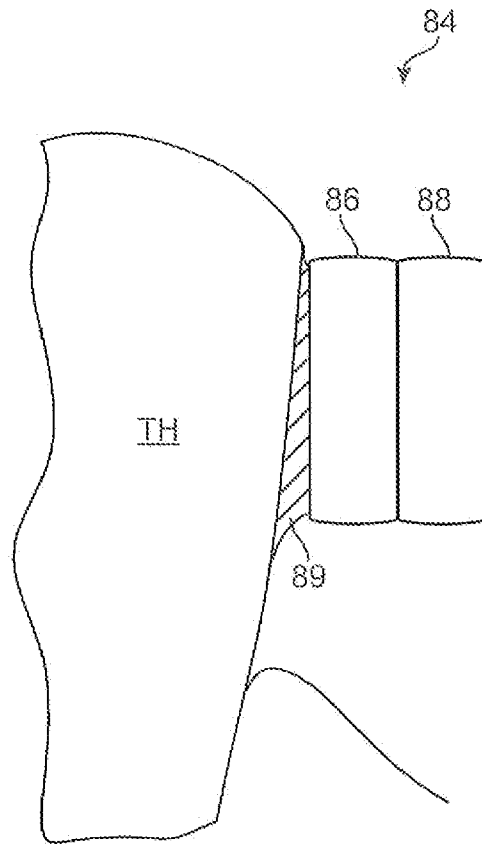

FIG. 12

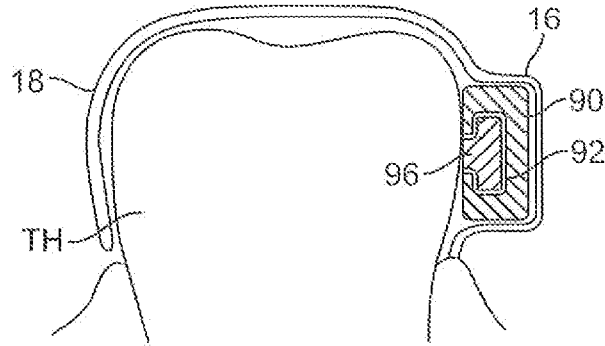

FIG. 13A

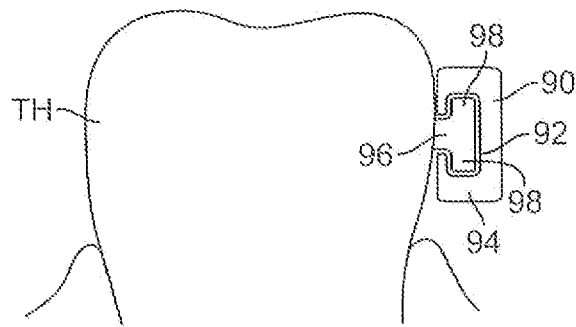

FIG. 13B

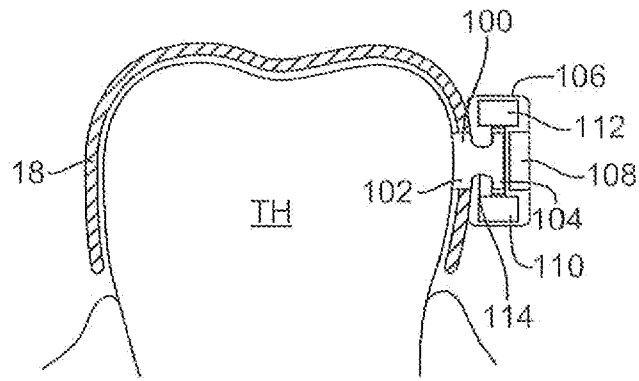

FIG. 14A

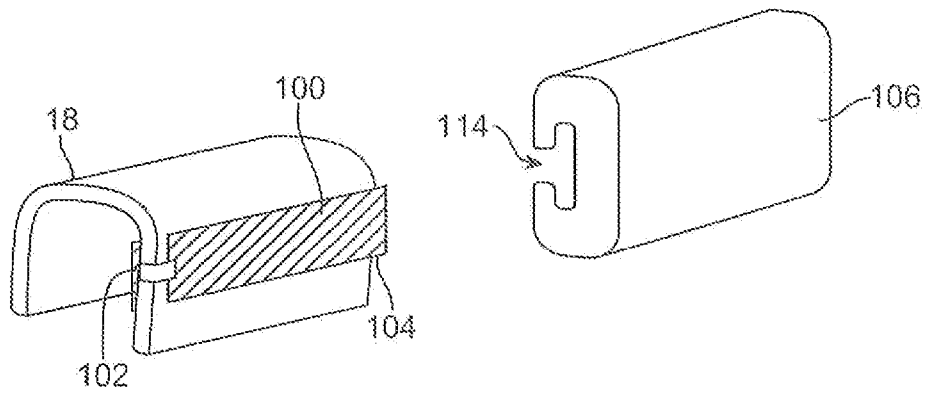

FIG. 14B

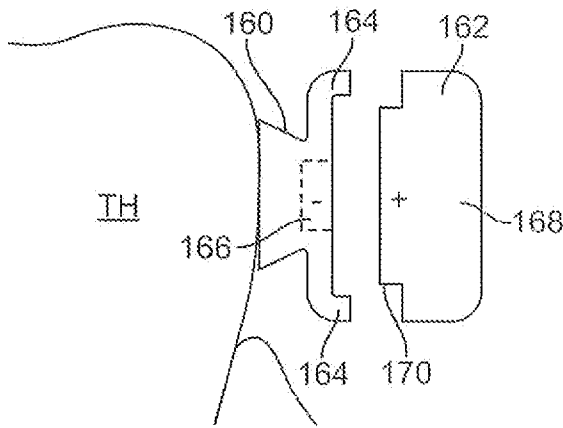

FIG. 16A

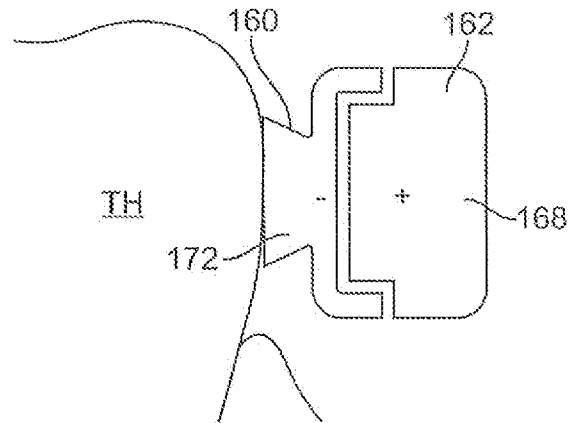

FIG. 16B

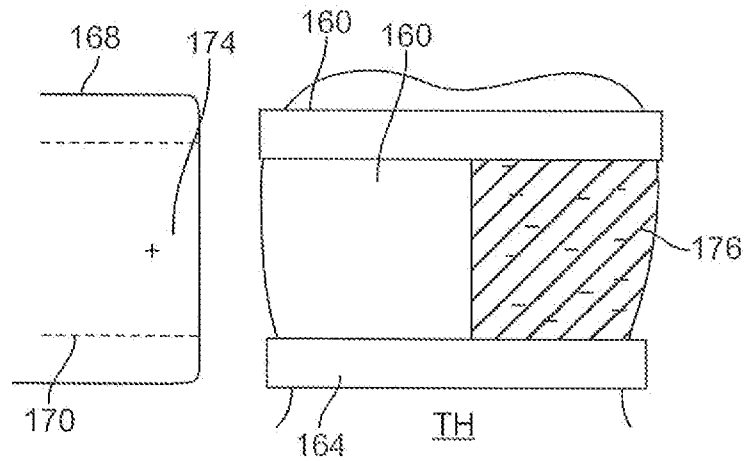

FIG. 16C

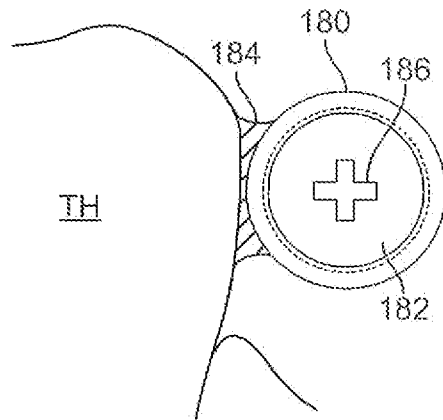

FIG. 17A

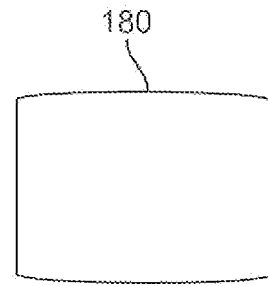

FIG. 17B

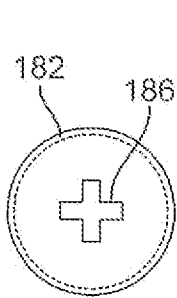

FIG. 17D

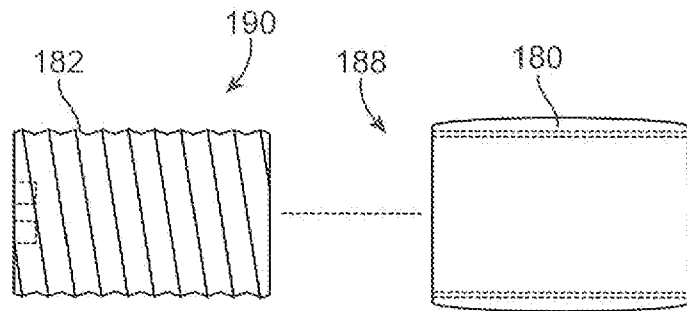

FIG. 17C

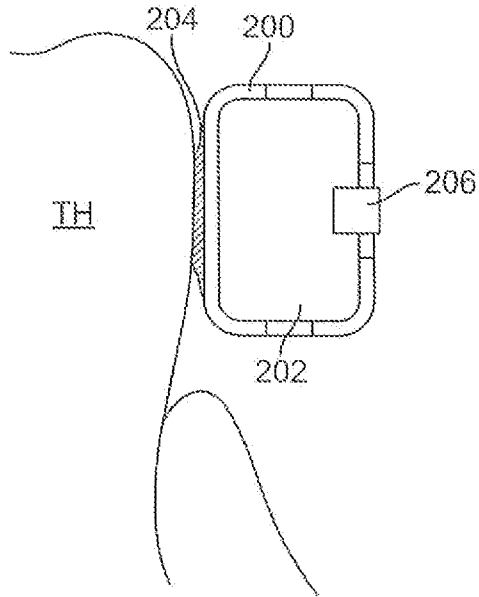

FIG. 18A

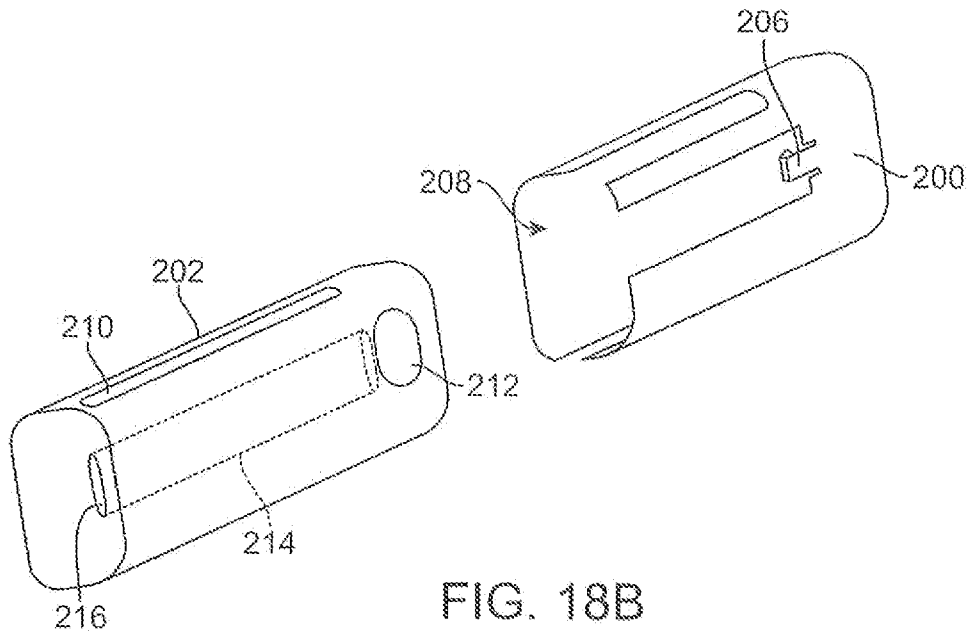

FIG. 18B

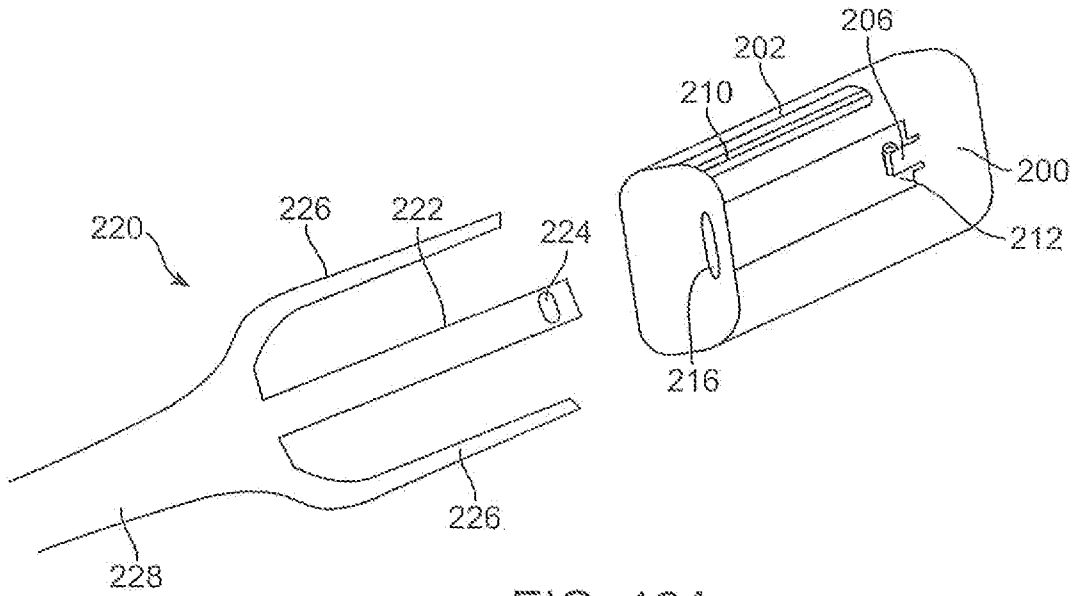

FIG. 19A

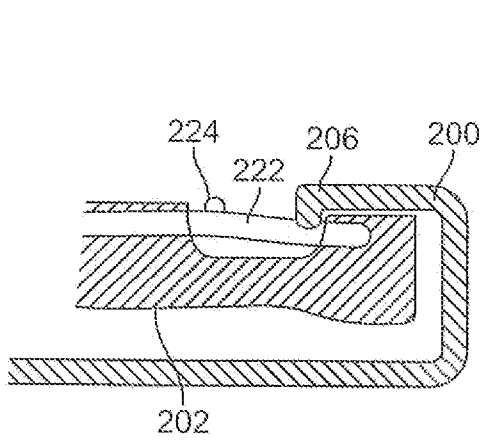

FIG. 19B

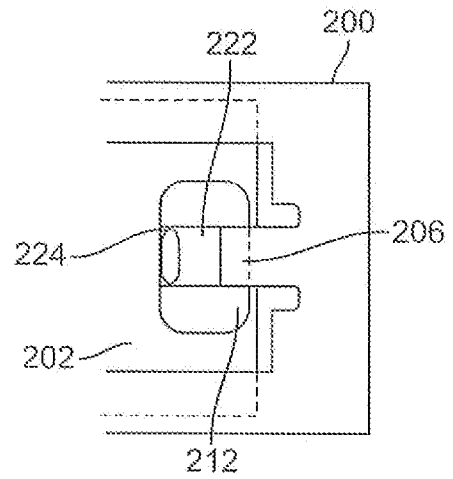

FIG. 19C

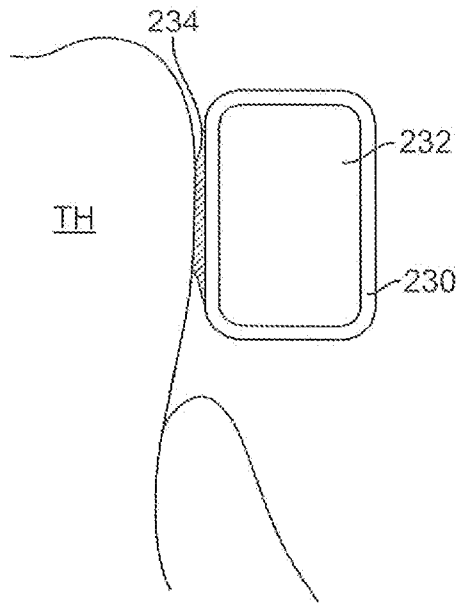

FIG. 20A

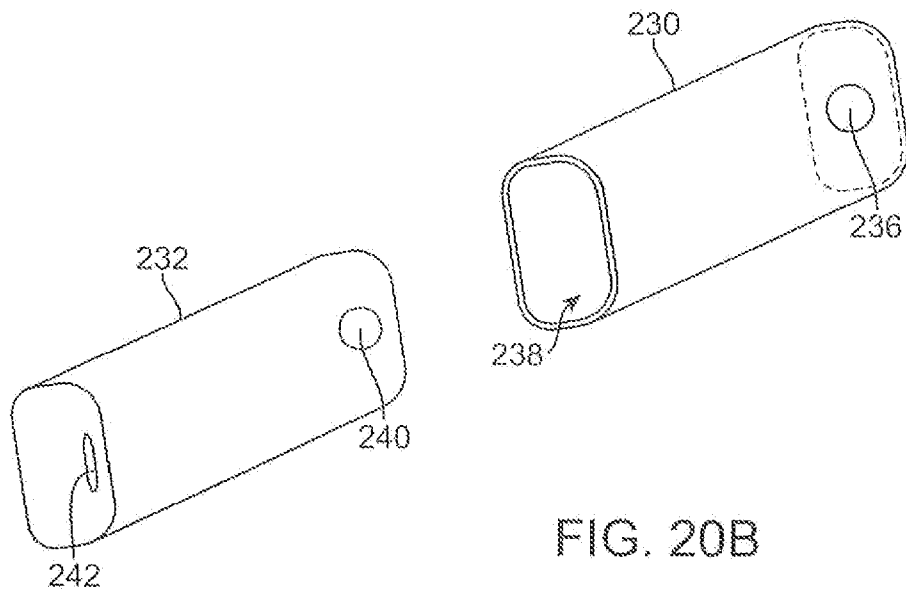

FIG. 20B

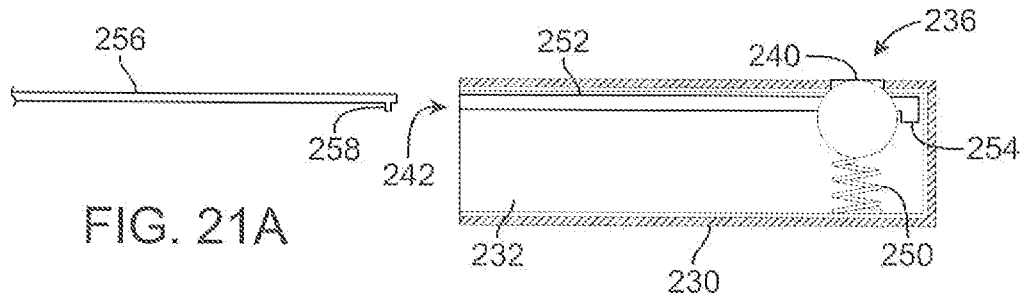

FIG. 21A

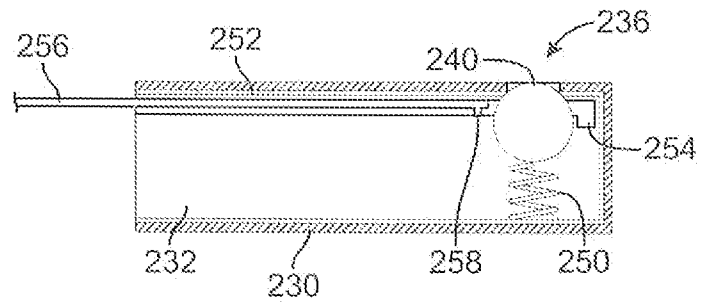

FIG. 21B

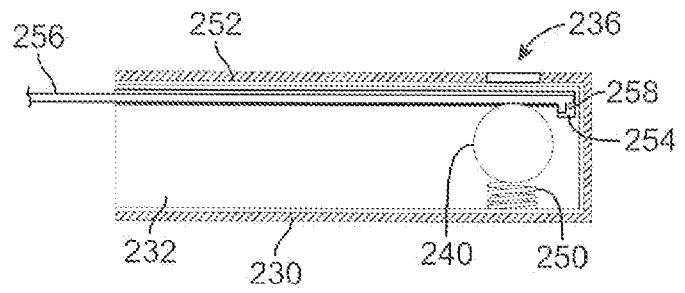

FIG. 21C

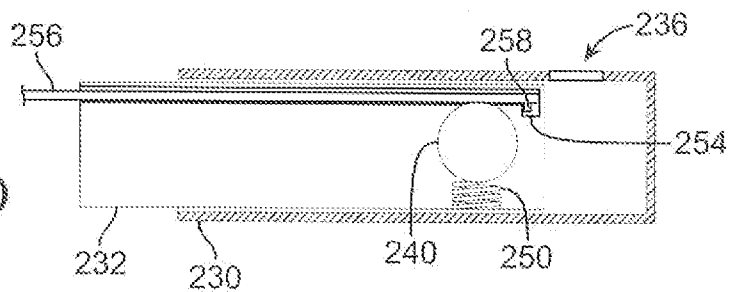

FIG. 21D

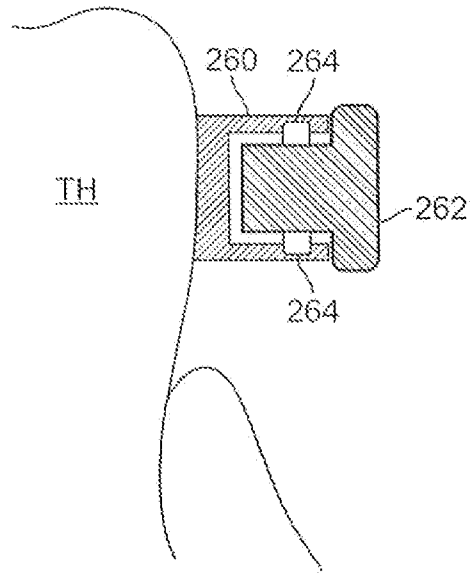

FIG. 22A

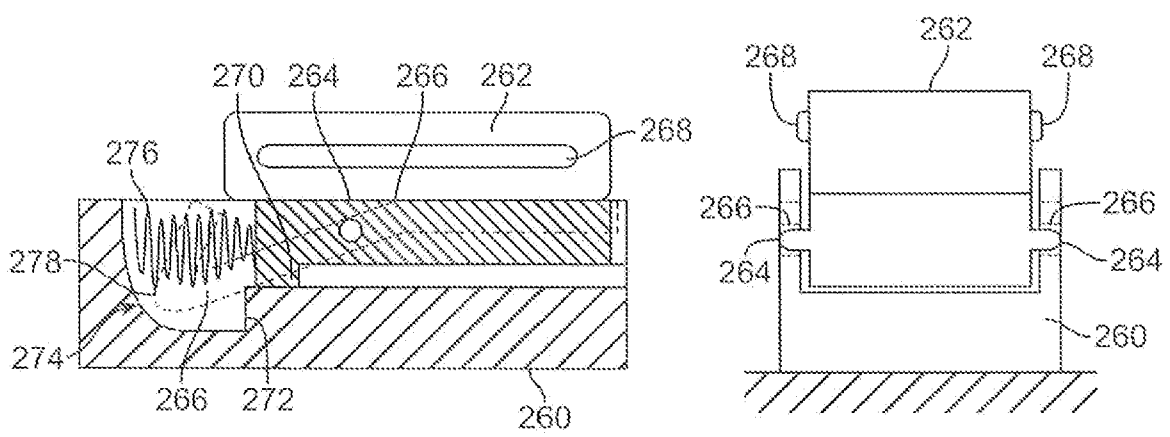

FIG. 22B

FIG. 22C

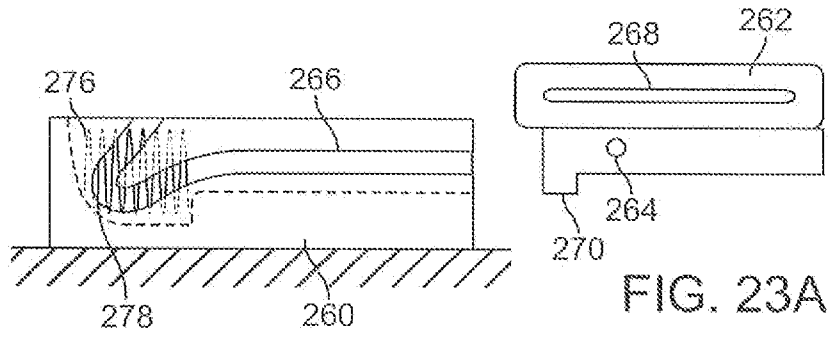

FIG. 23A

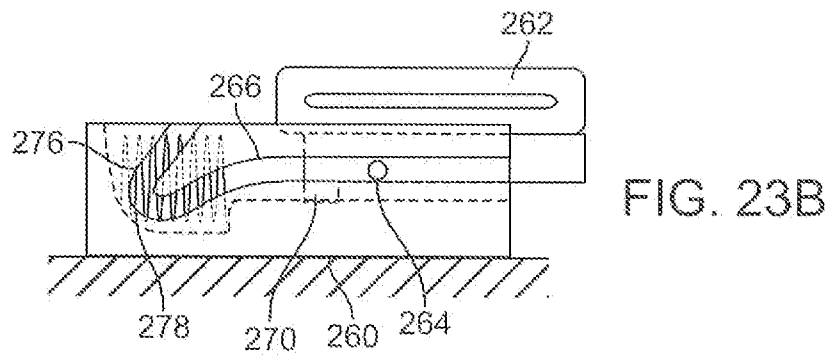

FIG. 23B

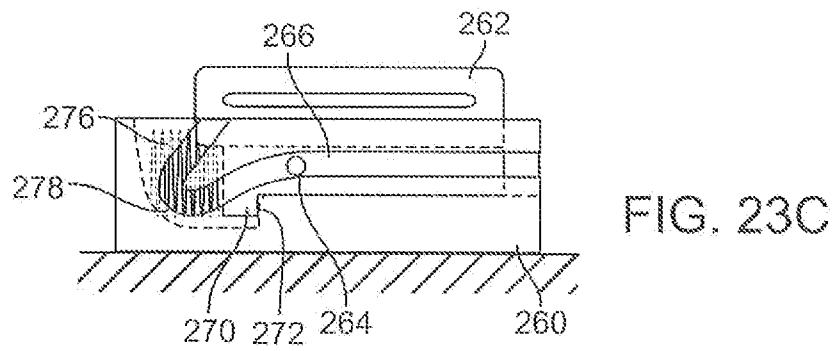

FIG. 23C

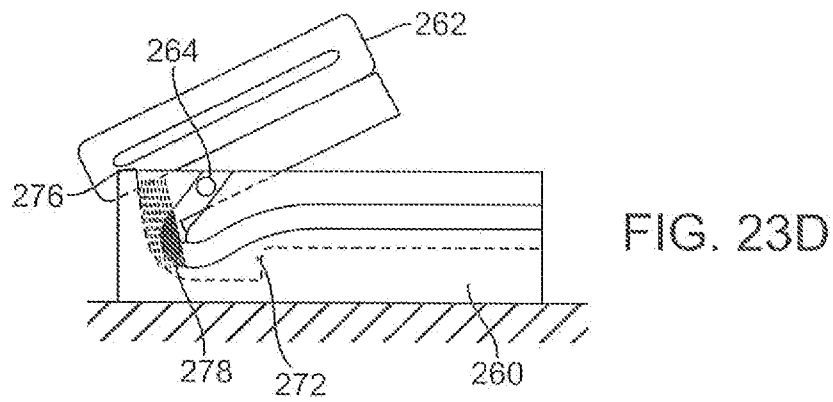

FIG. 23D

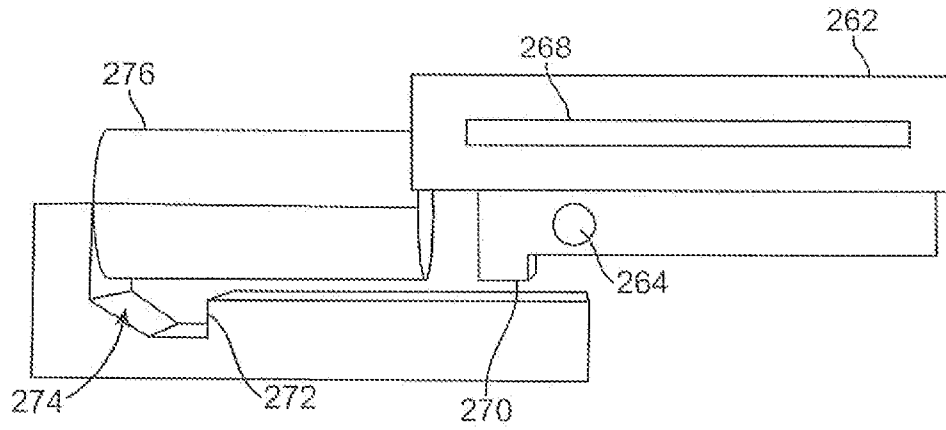

FIG. 24A

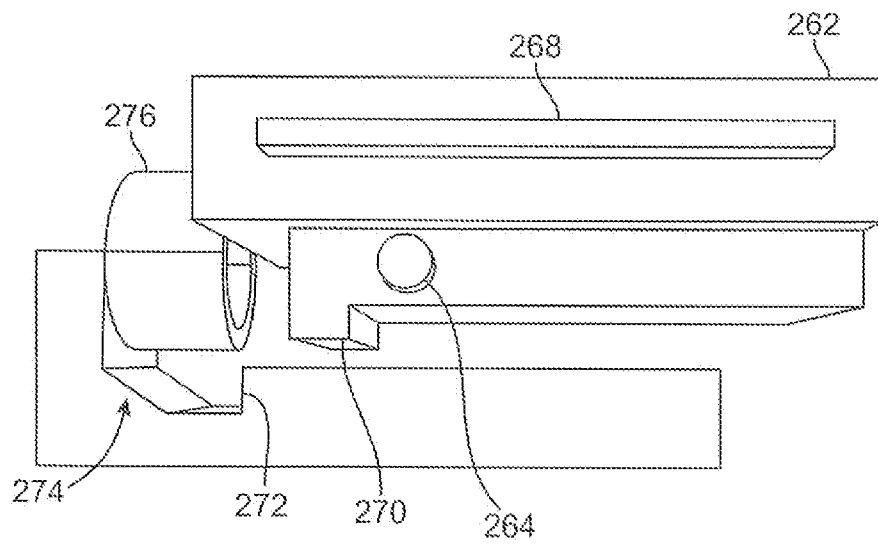

FIG. 24B

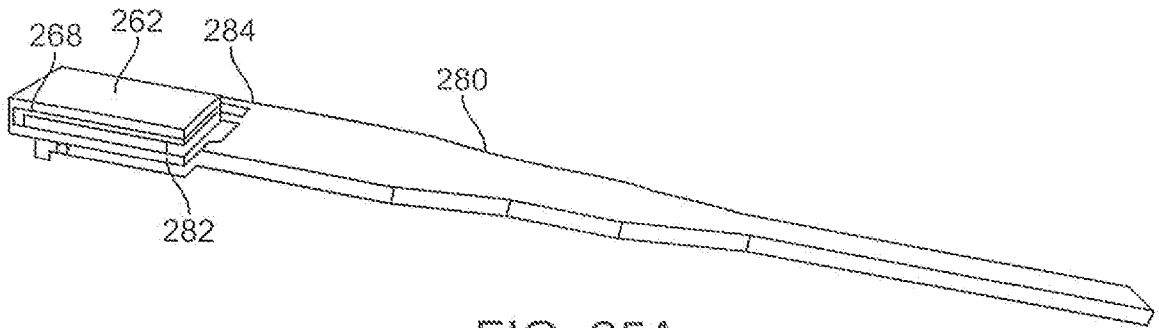

FIG. 25A

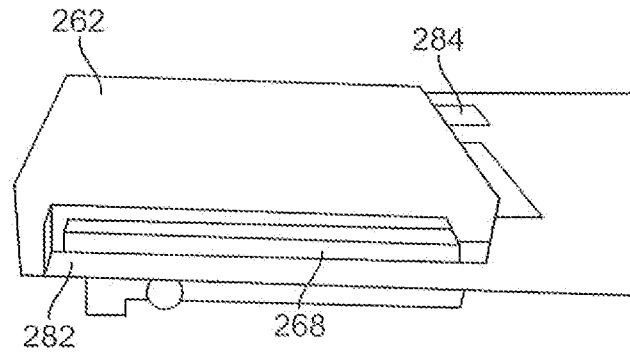

FIG. 25B

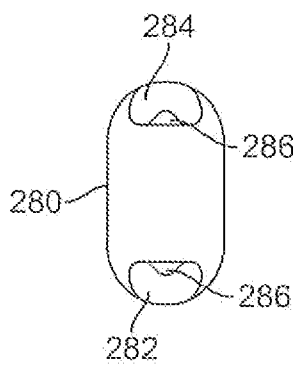

FIG. 25D

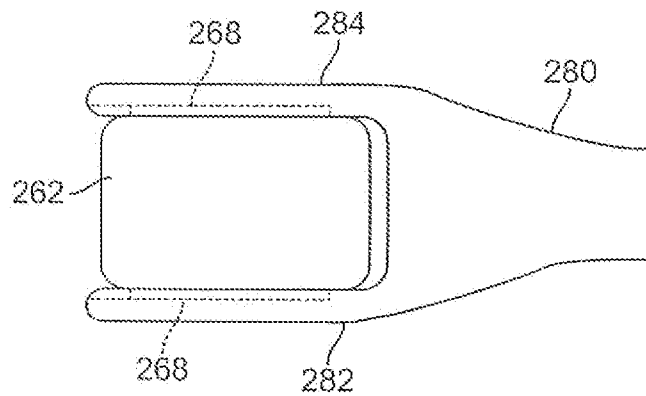

FIG. 25C

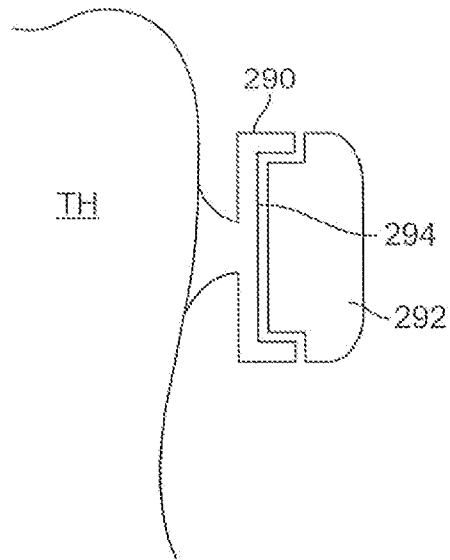

FIG. 26A

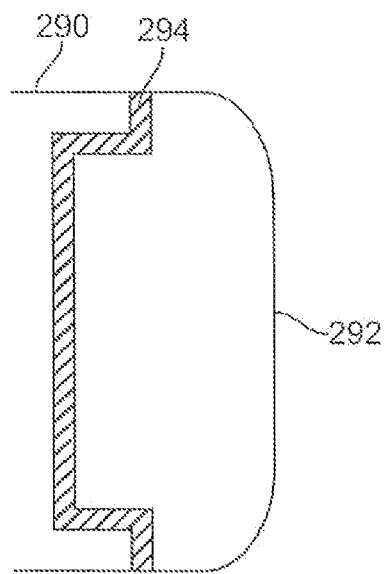

FIG. 26B

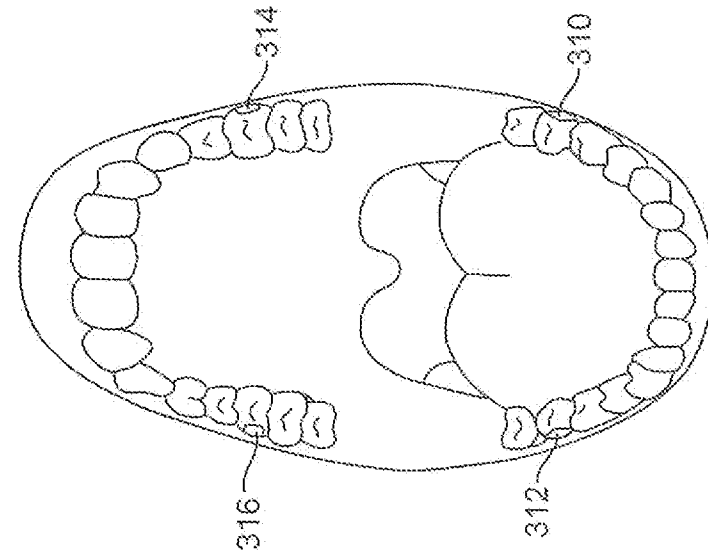

FIG. 27B

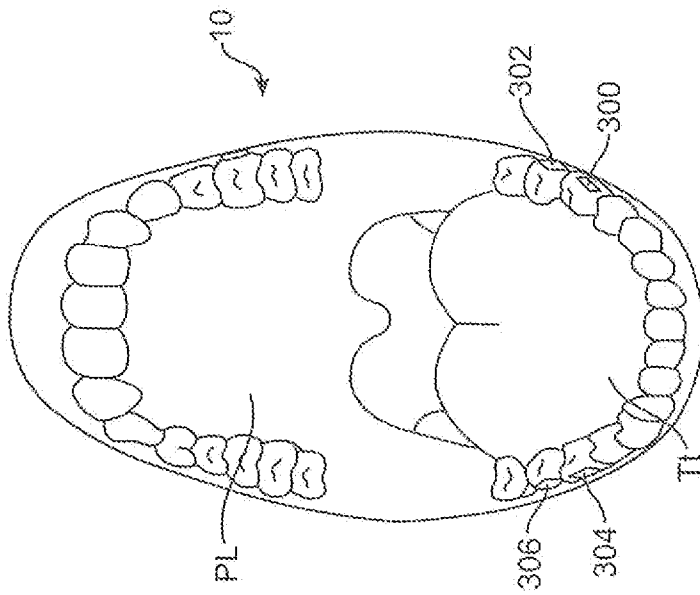

FIG. 27A