



- (51) **International Patent Classification:**
F24C 7/08 (2006.01) *G06F 3/041* (2006.01)
- (21) **International Application Number:**
PCT/EP2016/063321
- (22) **International Filing Date:**
10 June 2016 (10.06.2016)
- (25) **Filing Language:** English
- (26) **Publication Language:** English
- (30) **Priority Data:**
15176186.3 10 July 2015 (10.07.2015) EP
- (71) **Applicant:** ELECTROLUX APPLIANCES AKTIEBOLAG [SE/SE]; S:t Göransgatan 143, 105 45 Stockholm (SE).
- (72) **Inventors:** **HOLZINGER, Jochen**; Electrolux Rothenburg GmbH Factory and Development, Bodelschwinghstr. 1, 91541 Rothenburg o. d. Tauber (DE). **HOFFMANN, Harald**; Electrolux Rothenburg GmbH Factory and Development, Bodelschwinghstr. 1, 91541 Rothenburg ob der Tauber (DE). **LEIKAM, Juergen**; Electrolux Rothenburg GmbH Factory and Development, Bodelschwinghstr. 1, 91541 Rothenburg ob der Tauber (DE).
- (74) **Agent:** BAUMGARTL, Gerhard; Electrolux Hausgeräte GmbH - Group Patents, P. O. Box 1036, 90327 Nürnberg (DE).

- (81) **Designated States** (unless otherwise indicated, for every kind of national protection available): AE, AG, AL, AM, AO, AT, AU, AZ, BA, BB, BG, BH, BN, BR, BW, BY, BZ, CA, CH, CL, CN, CO, CR, CU, CZ, DE, DK, DM, DO, DZ, EC, EE, EG, ES, FI, GB, GD, GE, GH, GM, GT, HN, HR, HU, ID, IL, IN, IR, IS, JP, KE, KG, KN, KP, KR, KZ, LA, LC, LK, LR, LS, LU, LY, MA, MD, ME, MG, MK, MN, MW, MX, MY, MZ, NA, NG, NI, NO, NZ, OM, PA, PE, PG, PH, PL, PT, QA, RO, RS, RU, RW, SA, SC, SD, SE, SG, SK, SL, SM, ST, SV, SY, TH, TJ, TM, TN, TR, TT, TZ, UA, UG, US, UZ, VC, VN, ZA, ZM, ZW.
- (84) **Designated States** (unless otherwise indicated, for every kind of regional protection available): ARIPO (BW, GH, GM, KE, LR, LS, MW, MZ, NA, RW, SD, SL, ST, SZ, TZ, UG, ZM, ZW), Eurasian (AM, AZ, BY, KG, KZ, RU, TJ, TM), European (AL, AT, BE, BG, CH, CY, CZ, DE, DK, EE, ES, FI, FR, GB, GR, HR, HU, IE, IS, IT, LT, LU, LV, MC, MK, MT, NL, NO, PL, PT, RO, RS, SE, SI, SK, SM, TR), OAPI (BF, BJ, CF, CG, CI, CM, GA, GN, GQ, GW, KM, ML, MR, NE, SN, TD, TG).

Declarations under Rule 4.17:

— of inventorship (Rule 4.17(iv))

Published:

— with international search report (Art. 21(3))

— before the expiration of the time limit for amending the claims and to be republished in the event of receipt of amendments (Rule 48.2(h))

(54) **Title:** A CONTROL UNIT FOR A DOMESTIC APPLIANCE

FIG 3

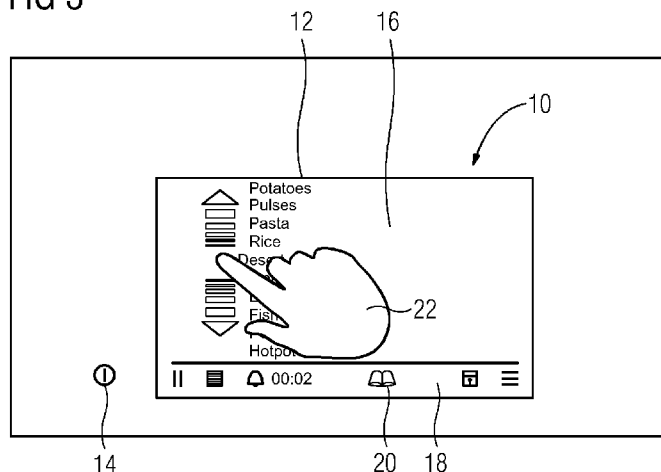

(57) **Abstract:** The present invention relates to a control unit (10) for a domestic appliance, in particular for a cooking appliance. The control unit (10) comprises at least one display (12) formed as an input-output device. At least a part of the display (12) is touch-sensitive and/or formed as a touch screen. The display (12) is switchable between a control mode and an information mode. The display (12) includes at least one area (16). In the control mode the area (16) illustrates symbols and/or touch switches for controlling the domestic appliance by a user. In the information mode the area (16) illustrates information as a two-dimensional representation for the user. The representation of information on the at least one area (16) is controlled or controllable by symbols and/or touch switches on said area (16). The control unit (10) includes a switch button (20) for switching over between the control mode and the information mode.

WO 2017/008964 A1

DescriptionA control unit for a domestic appliance

5 The present invention relates to a control unit for a domestic appliance. In particular, the present invention relates to a control unit for a cooking appliance. Further, the present invention relates to a domestic appliance, in particular a cooking appliance comprising at least one control unit.

10

For a domestic appliance, in particular a cooking appliance, information relating to said domestic appliance may be provided by software. The representation of information is realized by an appropriate display. For example, a mobile computer device comprises application software for downloading and presenting cooking recipes on a display. Further, the mobile computer device
15 may be provided for controlling the cooking appliance.

It is an object of the present invention to provide a control
20 unit for a domestic appliance, wherein said control unit allows the presentation of information by low complexity.

The object is achieved by the control unit according to claim 1.

25 The present invention relates to a control unit for a domestic appliance, in particular for a cooking appliance, wherein

- the control unit comprises at least one display formed as an input-output device,
- at least a part of the display is touch-sensitive and/or
30 formed as a touch screen,
- the display is switchable between a control mode and an information mode,
- the display includes at least one area,

- in the control mode the area illustrates symbols and/or touch switches for controlling the domestic appliance by a user,
- in the information mode the area illustrates information as a two-dimensional representation for the user,
- the representation of information on the area is controlled or controllable by at least one symbol and/or touch switch on said area, and
- the control unit includes a switch button for switching over between the control mode and the information mode.

The main idea of the present invention is that a predetermined area of the touch screen is alternating used as control area for the domestic appliance and as output device for information. The switch button allows a simple switching over between the control mode and the information mode of the control unit. The multiple use of the touch screen minimizes the complexity of the control unit.

Preferably, the display includes at least one further area representing at least one symbol and/or touch switch for controlling the control unit and/or the domestic appliance by the user in the control mode and in the information mode. The further area of the display allows that some operations may be performed by the user, when the touch screen is in the information mode.

In particular, the further area of the display remains unchanged, when the display is switched between the control mode and the information mode. The further area of the display guarantees that some operations may be always performed by the user.

For example, the switch button is a touch switch.

Preferably, the touch switch is arranged within the further area of the display. The user can always switch over between the control mode and the information mode.

5 In particular, the two-dimensional representation of information includes text, one or more pictures and/or one or more symbols. For example, the display may represent information which is conventionally provided in paper form.

10 Further, the control unit may comprise at least one slide function, so that the two-dimensional representation of information is moveable upwards, downwards and/or sideways within the area.

Moreover, the control unit may comprise at least one zoom function, so that the two-dimensional representation of information
15 is enlargeable and/or scalable within the area.

For example, information representable on the area is stored or storable in at least one memory of the control unit or the domestic appliance.
20

Alternatively or additionally, the control unit is connected or connectable to the internet, so that information is downloadable or downloaded from the internet to the control unit. The information downloaded may be stored in the memory of the control
25 unit or the domestic appliance, so that the user may select said information at a later date.

The control unit may be connected or connectable to the internet
30 via a local area network and/or a wireless local area network.

Furthermore, the control unit may be connected or connectable to a mobile computer device, so that information is transferable from said mobile computer device to the control unit.

Additionally, the control unit may comprise an on-off switch, wherein preferably said on-off switch is arranged outside and/or besides the touch screen.

5

According to a preferred embodiment, the domestic appliance is a cooking appliance, wherein the display is switchable between a cooking mode and a recipe mode, and wherein the switch button is a recipe button for switching over between the cooking mode and the recipe mode, and wherein preferably the recipe button is ar-
10 ranged within the further area of the touch screen.

Further, the domestic appliance may be a cooking hob, wherein the display is an integrated part of a cooking panel.

15

Moreover, the complete display may be formed as a touch screen.

At last, the present invention relates to a domestic appliance, in particular a cooking appliance comprising at least one control unit mentioned above.
20

Novel and inventive features of the present invention are set forth in the appended claims.

25 The present invention will be described in further detail with reference to the drawing, in which

FIG 1 illustrates a schematic view of a user interface of a cooking hob according to the prior art,

30

FIG 2 illustrates a schematic view of the user interface of the cooking hob according to a preferred embodiment of the present invention,

- FIG 3 illustrates a schematic view of the user interface of the cooking hob according to the preferred embodiment of the present invention, wherein a recipe mode is activated,
- 5 FIG 4 illustrates a schematic view of the user interface of the cooking hob according to the preferred embodiment of the present invention, wherein a menu item of cooking recipes is displayed,
- 10 FIG 5 illustrates a schematic view of the user interface of the cooking hob according to the preferred embodiment of the present invention, wherein a selected cooking recipe is displayed,
- 15 FIG 6 illustrates a schematic view of the user interface of the cooking hob according to the preferred embodiment of the present invention, wherein a further part of the selected cooking recipe is displayed,
- 20 FIG 7 illustrates a schematic view of the user interface of the cooking hob according to the preferred embodiment of the present invention, wherein the further part the selected cooking recipe is displayed,
- 25 FIG 8 illustrates a schematic view of the user interface of the cooking hob according to the preferred embodiment of the present invention, wherein the user interface is in the cooking mode again,
- 30 FIG 9 illustrates a schematic view of the user interface of the cooking hob according to the preferred embodiment of the present invention, wherein the user interface is still in the cooking mode, and

FIG 10 illustrates a schematic view of the user interface of the cooking hob according to the preferred embodiment of the present invention, wherein the selected cooking recipe is displayed again.

5

FIG 1 illustrates a schematic view of a user interface 10 of a cooking hob according to the prior art. In this example, the user interface 10 comprises a touch screen 12 and an on-off switch 14. In general, the user interface 10 comprises a display 12 and the on-off switch 14, wherein at least a part of the display 12 is touch-sensitive and/or formed as touch screen. The touch screen 12 is an input-output device for controlling the cooking hob. In this example, the touch screen 12 is rectangular. The on-off switch 14 is arranged besides the touch screen 12 and provided for activating and deactivating the cooking hob.

The touch screen 12 includes a first area 16 and a second area 18. In this example, the first area 16 forms a bigger part of the touch screen 12, while the second area 18 forms a remaining small part of said touch screen 12. The first area 16 includes symbols representing cooking zones of the cooking hob. For example, said cooking zones are activated, controlled and/or deactivated by touching the corresponding symbols on the first area 16. The second area 18 includes symbols for controlling the cooking hob. The symbols on the second area 18 are provided for displaying states of the cooking hob and/or as touch switches for controlling the cooking hob. For example, the second area 18 includes a timer.

FIG 2 illustrates a schematic view of the user interface 10 of the cooking hob according to a preferred embodiment of the present invention. The user interface 10 of the present invention is similar to the user interface 10 according to the prior art shown in FIG 1.

Additionally, the user interface 10 according to the present invention includes a recipe button 20. Said recipe button 20 is provided for switching over between a cooking mode and a recipe mode. The recipe button 20 is arranged in the second area 18 of the user interface 10. In FIG 2 the user interface 10 is in the cooking mode, wherein the symbols representing the cooking zones are shown in the first area 16 of the user interface 10. The recipe button 20 is a touch switch and operable by the user's hand 22.

FIG 3 illustrates a schematic view of the user interface 10 of the cooking hob according to the preferred embodiment of the present invention, wherein a recipe mode is activated. The recipe mode has been activated by touching the recipe button 20.

In the recipe mode an electronic cookbook is represented in the first area 16 of the touch screen 12. In the second area 18 of the touch screen 12 the same symbols are represented in the recipe mode as well as in the cooking mode. Thus, the recipe button 20 is visible and operable in the cooking mode and in the recipe mode. Also the other symbols of the second area 18 remain visible and/or operable in the cooking mode and in the recipe mode.

In FIG 3 a welcome page of the recipe mode displays a menu item of cooking recipes. A number of recipes are listed and may be selected by touching the corresponding position on the first area 16 of the touch screen 12. In the recipe mode an electronic cookbook is readable by the user. The first area 16 of the touch screen 12 acts as an e-book reader.

FIG 4 illustrates a schematic view of the user interface 10 of the cooking hob according to the preferred embodiment of the present invention, wherein the menu item of cooking recipes is

displayed. FIG 4 demonstrates how a certain recipe is selected by the user. Said certain recipe is selected by the user and the corresponding position is touched by the user's hand 22.

5 FIG 5 illustrates a schematic view of the user interface 10 of the cooking hob according to the preferred embodiment of the present invention, wherein a selected cooking recipe is displayed. Said cooking recipe has been selected by the user before. The represented cooking recipe includes a picture showing
10 the dish and a table of the condiments and their amounts.

FIG 6 illustrates a schematic view of the user interface 10 of the cooking hob according to the preferred embodiment of the present invention, wherein a further part of the selected cooking
15 recipe is displayed. In the recipe mode the first area 16 of the touch screen 12 comprises a slide function, so that the representation of the selected cooking recipe may be moved upwards and downwards. Alternatively or additionally, the representation of the selected cooking recipe may be moved sideways. In FIG 6
20 the first area 16 of the touch screen 12 represents an instruction for the preparation of the dish. In this example, the instruction is represented in written text.

The cooking recipes may also include data for adjusting the
25 heating elements. For example, said data include the position and/or the operation mode of the heating element. Further, the data may include the temperature and/or the power level of the heating element. Moreover, the data may include the cooking time for performing the cooking recipe. For example, the data for ad-
30 justing the heating element are transferred to said heating element by actuating a button of the user interface 10, wherein preferably the heating element is started by further actuating said button or another button.

If a first step of the cooking recipe is performed, then preferably the data for a second step are automatically transferred to the heating element and/or to another heating element, wherein the heating element or heating elements for said second step are
5 started by actuating a button of the user interface 10 by the user. More generally, if a current step of the cooking recipe is performed, then preferably the data for a subsequent step are automatically transferred to one or more corresponding heating
10 elements, wherein the heating element or heating elements for said subsequent step are started by actuating a corresponding button of the user interface 10 by the user.

FIG 7 illustrates a schematic view of the user interface 10 of the cooking hob according to the preferred embodiment of the
15 present invention, wherein the further part of the selected cooking recipe is displayed. In FIG 7 the first area 16 of the touch screen 12 shows also the instruction for the preparation of the dish. The second area 18 of the touch screen 12 includes the recipe button 20. A touch of the recipe button 20 by the
20 user's hand 22 effects switching over from the recipe mode to the cooking mode again.

FIG 8 illustrates a schematic view of the user interface 10 of the cooking hob according to the preferred embodiment of the
25 present invention, wherein the user interface 10 is in the cooking mode again. The cooking mode has been activated again by the touch of the recipe button 20 by the user's hand 22. The user may control the cooking zones represented by the symbols on the first area 16 of the user interface 12 in the cooking mode.

30

FIG 9 illustrates a schematic view of the user interface 10 of the cooking hob according to the preferred embodiment of the present invention, wherein the user interface is still in the cooking mode. The second area 18 of the touch screen 12 includes

the recipe button 20. A further touch of the recipe button 20 by the user's hand 22 effects switching over from the cooking mode to the recipe mode again.

5 FIG 10 illustrates a schematic view of the user interface 10 of the cooking hob according to the preferred embodiment of the present invention, wherein the selected cooking recipe is displayed again. The recipe mode is activated again, after the recipe button 20 has been touched by the user's hand 22.

10

The presentations in FIG 7 to FIG 10 clarify the switching over between the recipe mode and the cooking mode by touching the recipe button 20 by the user's hand 22. The user can easily switch over between the recipe mode and the cooking mode. The first area 16 of the touch screen 12 acts as an e-book reader
15 for the cookbook on the one hand and as a control device of the cooking zones on the other hand.

According to an alternative embodiment of the present invention
20 the user interface includes a graphic display formed as an output device and an input device arranged out of said graphic display. For example, the input device includes a touch area or at least one adjusting knob. Thus, in the alternative embodiment the input device and the output device of the user interface are
25 separate parts. In the information mode the graphic display may indicate a menu of cooking recipes, wherein one of said cooking recipes may be selected by an actuation of the adjusting knob or by contacting the touch area. Then, the selected cooking recipe is indicated by the graphic display, wherein preferably said
30 cooking recipe includes the picture showing the dish and/or the table of the condiments and/or their amounts. In the control mode the graphic display may indicate current parameter values of the cooking process by symbols, numbers and/or letters. Said parameter values may be adjusted or changed by actuating the

touch area or the adjusting knob of the input device by the user.

The user interface according to the present invention includes an integrated electronic cookbook. Said electronic cookbook is easy to handle and read. The user does not need any cookbook in paper form. For example, the cooking recipes are stored in a memory of the user interface 10, so that the user may select and read the cooking recipe all the time.

10

Further, the cooking recipes may be downloaded from the internet by the user. For example, the user interface 10 and/or the cooking hob are connected or connectable to the internet via a local area network (LAN) or a wireless local area network (WLAN). According to another example, a mobile computer device is connected or connectable to the internet via the wireless local area network (WLAN) or a mobile communications network, while the user interface 10 and/or the cooking hob are connected or connectable to said mobile computer device via a standardized wireless or wiring connection. For example, a Bluetooth connection may be used between the user interface 10 and/or the cooking hob on the one side and the mobile computer device on the other side. The cooking recipes may be downloaded from the homepage of the producer of the cooking hob or from a homepage related to cooking recipes. The cooking recipes downloaded may also be stored in the memory of the user interface 10, so that the user may select and read the cooking recipe downloaded at a later date.

20

The user interface 10 mentioned above is provided for the cooking hob. Further, the user interface 10 may be also provided for a cooking oven and a microwave oven. Moreover, the user interface 10 may be provided for other domestic appliances, wherein

arbitrary instructions or information for the user are represented by the user interface 10.

Although an illustrative embodiment of the present invention has
5 been described herein with reference to the accompanying drawing, it is to be understood that the present invention is not limited to that precise embodiment, and that various other changes and modifications may be affected therein by one skilled in the art without departing from the scope or spirit of the invention. All such changes and modifications are intended to be
10 included within the scope of the invention as defined by the appended claims.

List of reference numerals

- 10 user interface
- 12 touch screen, display
- 14 on-off switch
- 16 first area of the touch screen
- 18 second area of the touch screen
- 20 recipe button
- 22 user's hand

Claims

1. A control unit (10) for a domestic appliance, in particular for a cooking appliance, wherein
- the control unit (10) comprises at least one display (12) formed as an input-output device,
 - at least a part of the display (12) is touch-sensitive and/or formed as a touch screen,
 - the display (12) is switchable between a control mode and an information mode,
 - the display (12) includes at least one area (16),
 - in the control mode the area (16) illustrates symbols and/or touch switches for controlling the domestic appliance by a user,
 - in the information mode the area (16) illustrates information as a two-dimensional representation for the user,
 - the representation of information on the area (16) is controlled or controllable by at least one symbol and/or touch switch on said area (16), and
 - the control unit (10) includes a switch button (20) for switching over between the control mode and the information mode.
2. The control unit (10) according to claim 1, characterised in that the display (12) includes at least one further area (18) representing at least one symbol and/or touch switch for controlling the control unit (10) and/or the domestic appliance by the user in the control mode and in the information mode.
3. The control unit (10) according to claim 2, characterised in that

the further area (18) of the display (12) remains unchanged, when the display (12) is switched between the control mode and the information mode.

- 5 4. The control unit (10) according to any one of the preceding claims,
characterised in that
the switch button is a touch switch (20), wherein preferably
said touch switch (20) is arranged within the further area
10 (18) of the display (12).
5. The control unit (10) according to any one of the preceding claims,
characterised in that
15 the two-dimensional representation of information includes text, one or more pictures and/or one or more symbols.
6. The control unit (10) according to any one of the preceding claims,
20 characterised in that
the control unit (10) comprises at least one slide function, so that the two-dimensional representation of information is moveable upwards, downwards and/or sideways within the area
(16).
- 25 7. The control unit (10) according to any one of the preceding claims,
characterised in that
the control unit (10) comprises at least one zoom function,
30 so that the two-dimensional representation of information is enlargeable and/or scalable within the area (16).
8. The control unit (10) according to any one of the preceding claims,

characterised in that
information representable on the area (16) is stored or
storable in at least one memory of the control unit (10) or
the domestic appliance.

5

9. The control unit (10) according to any one of the preceding
claims,

characterised in that

10

the control unit (10) is connected or connectable to the in-
ternet, so that information is downloadable or downloaded
from the internet to the control unit (10), wherein prefera-
bly the control unit (10) is connected or connectable to the
internet via a local area network (LAN) and/or a wireless
local area network (WLAN).

15

10. The control unit (10) according to any one of the preceding
claims,

characterised in that

20

the control unit (10) is connected or connectable to a mo-
bile computer device, so that information is transferable
from said mobile computer device to the control unit (10).

11. The control unit (10) according to any one of the preceding
claims,

25

characterised in that

the control unit (10) comprises an on-off switch (14),
wherein preferably said on-off switch (14) is arranged out-
side and/or besides the display (12).

30

12. The control unit (10) according to any one of the preceding
claims,

characterised in that

the domestic appliance is a cooking appliance, wherein the display (12) is switchable between a cooking mode and a recipe mode, and wherein the switch button is a recipe button (20) for switching over between the cooking mode and the recipe mode, and wherein preferably the recipe button (20) is arranged within the further area (18) of the display (12).

5

10

13. The control unit (10) according to claim 12, characterised in that the domestic appliance is a cooking hob, wherein the display (12) is an integrated part of a cooking panel.

15

14. The control unit (10) according to any one of the preceding claims, characterised in that the complete display (12) is formed as a touch screen.

20

15. A domestic appliance, in particular a cooking appliance, comprising at least one control unit (10), characterised in that the domestic appliance comprises at least one control unit (10) according to any one of the claims 1 to 14.

FIG 1

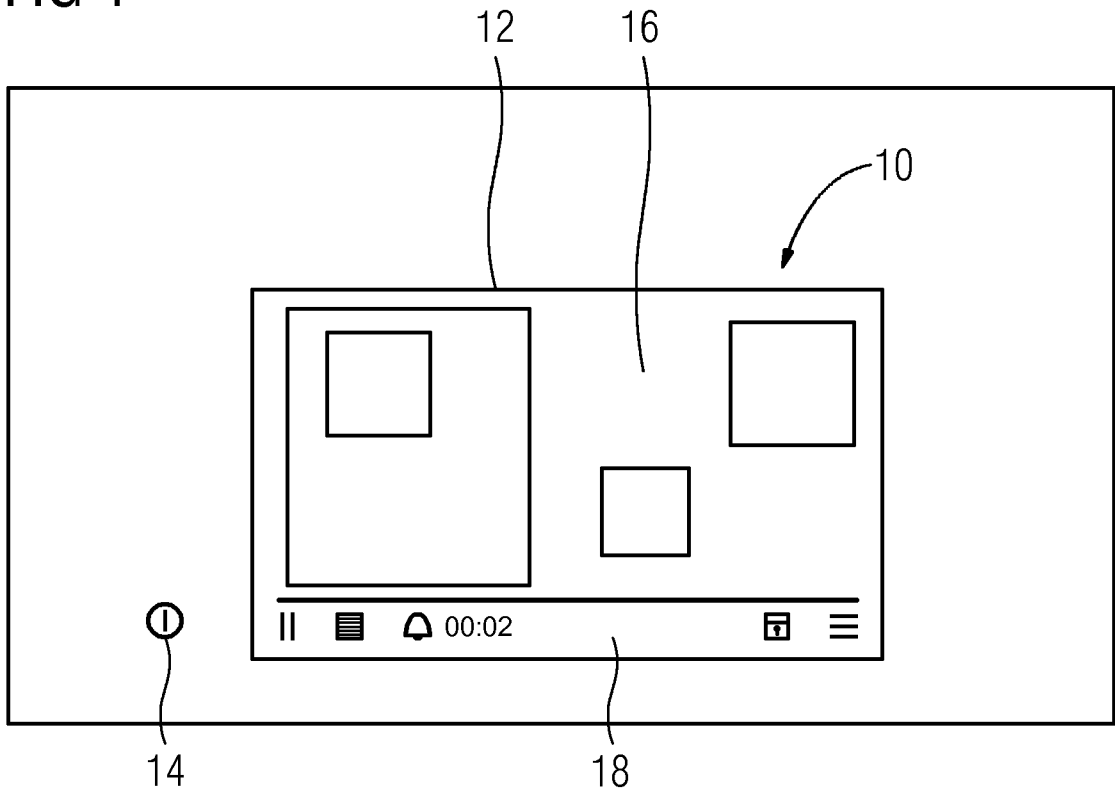

FIG 2

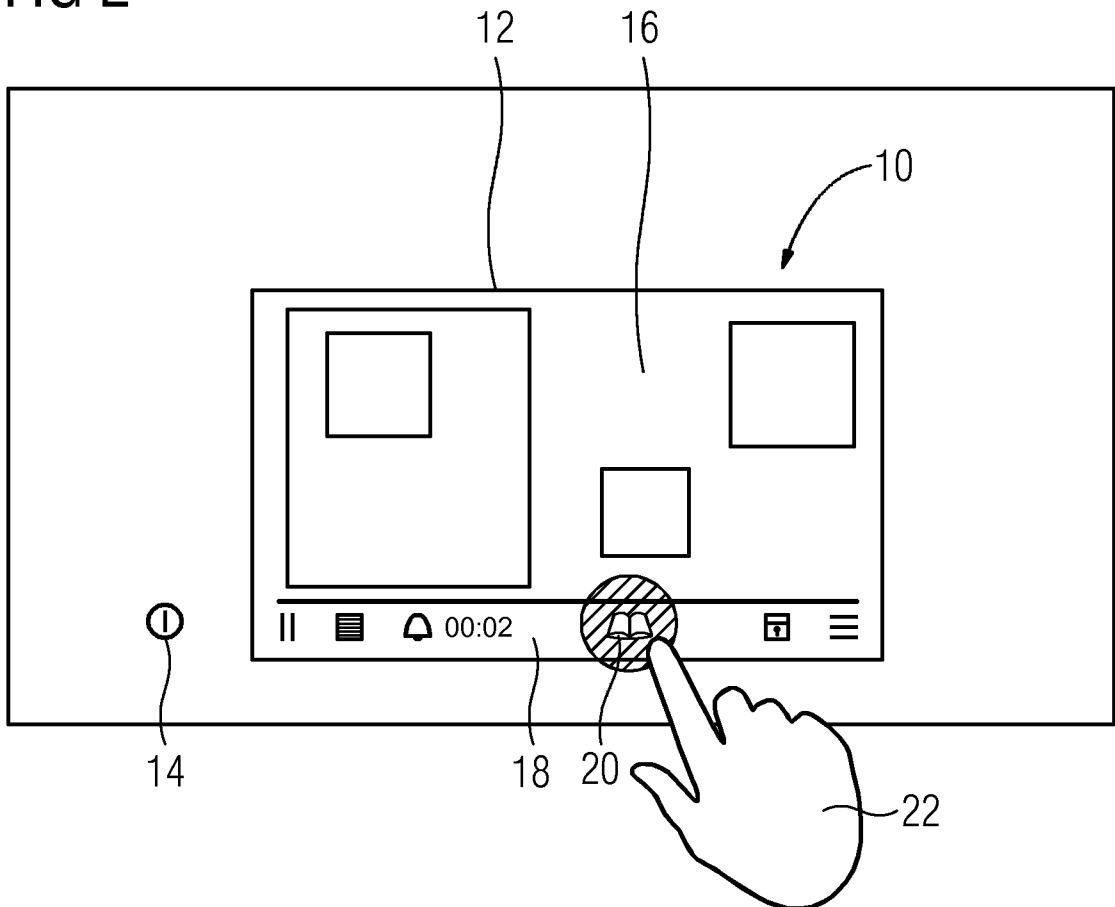

FIG 3

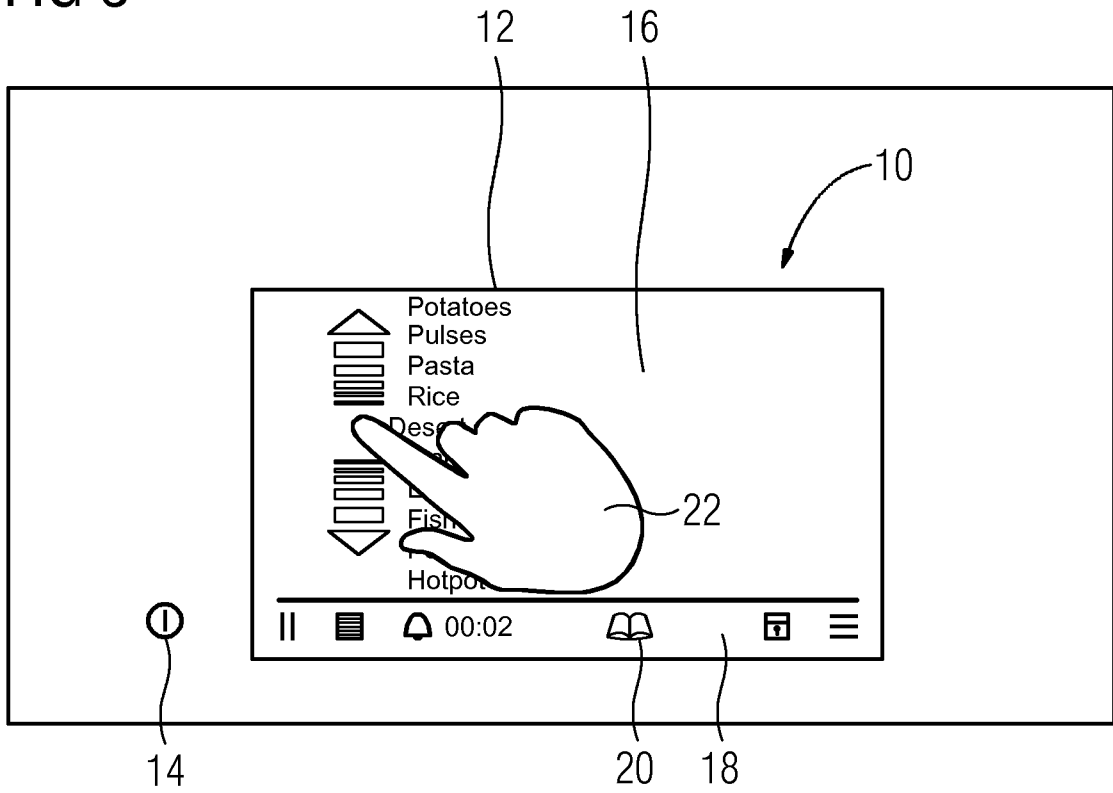

FIG 4

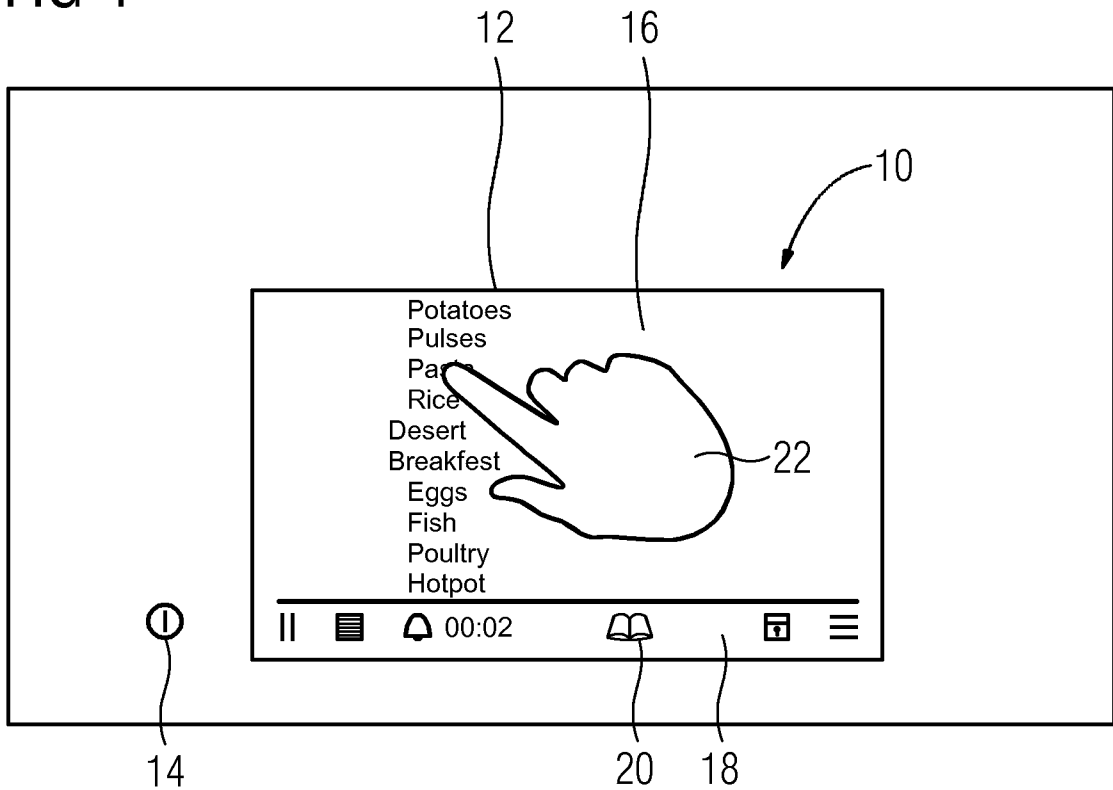

FIG 5

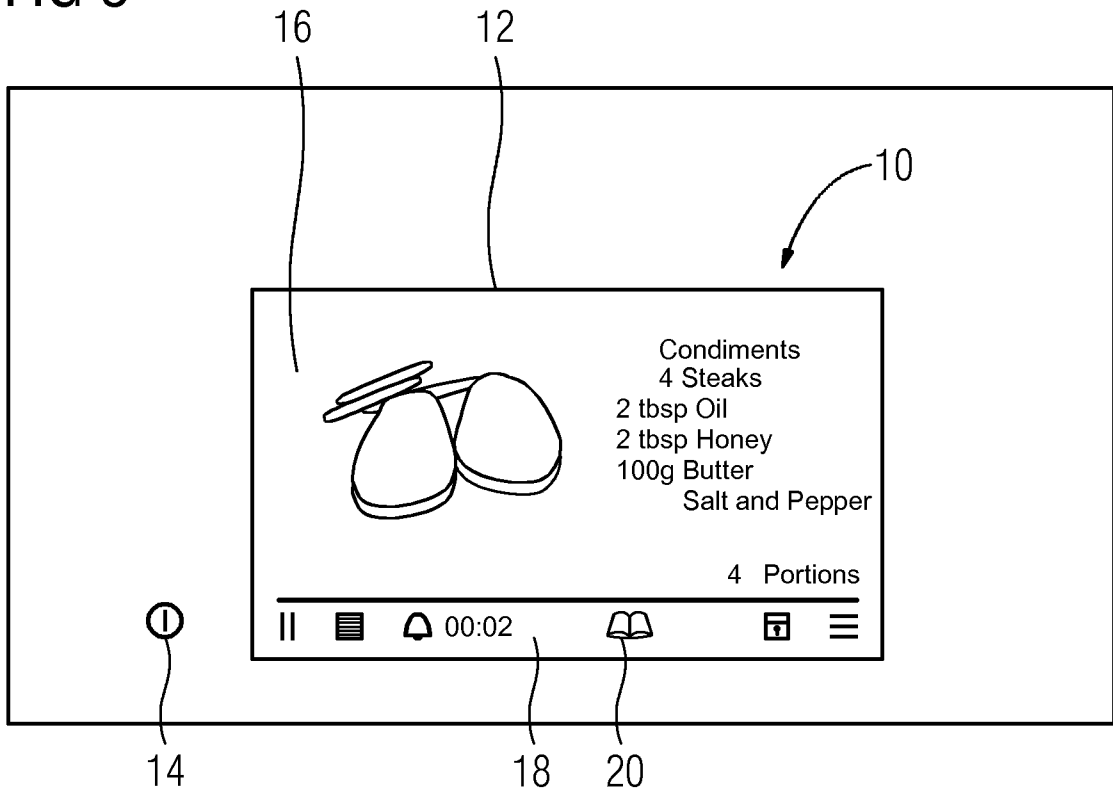

FIG 6

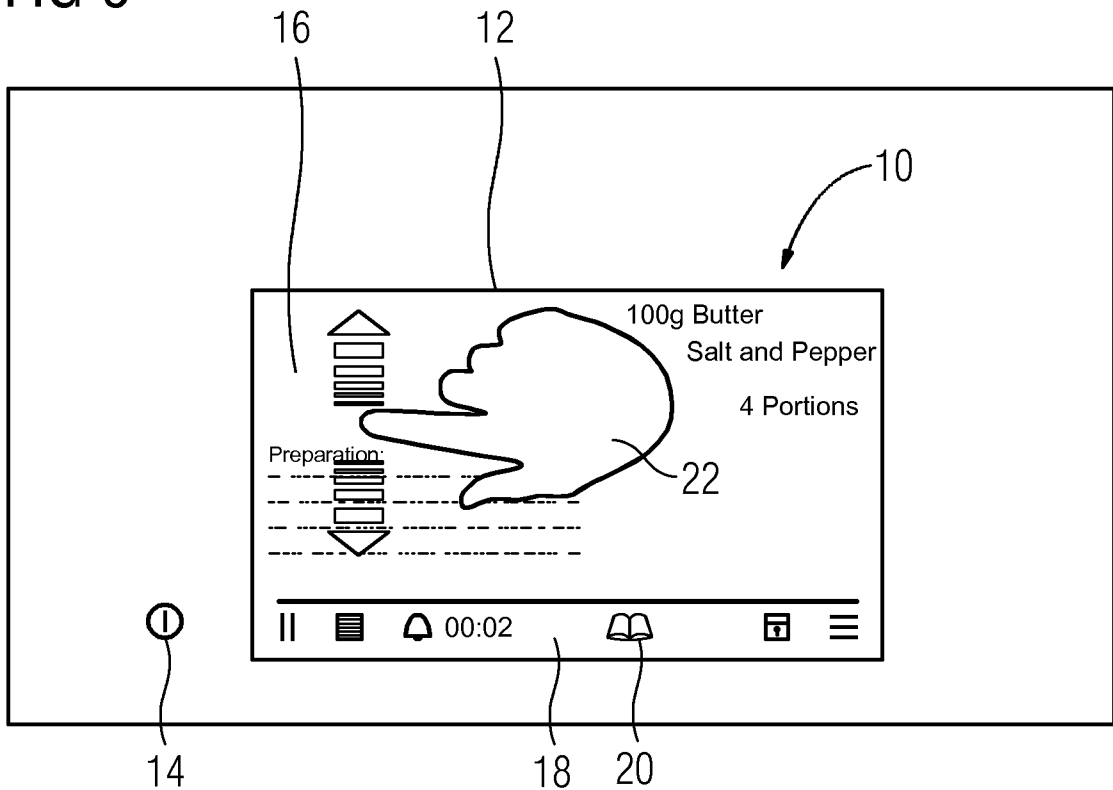

FIG 7

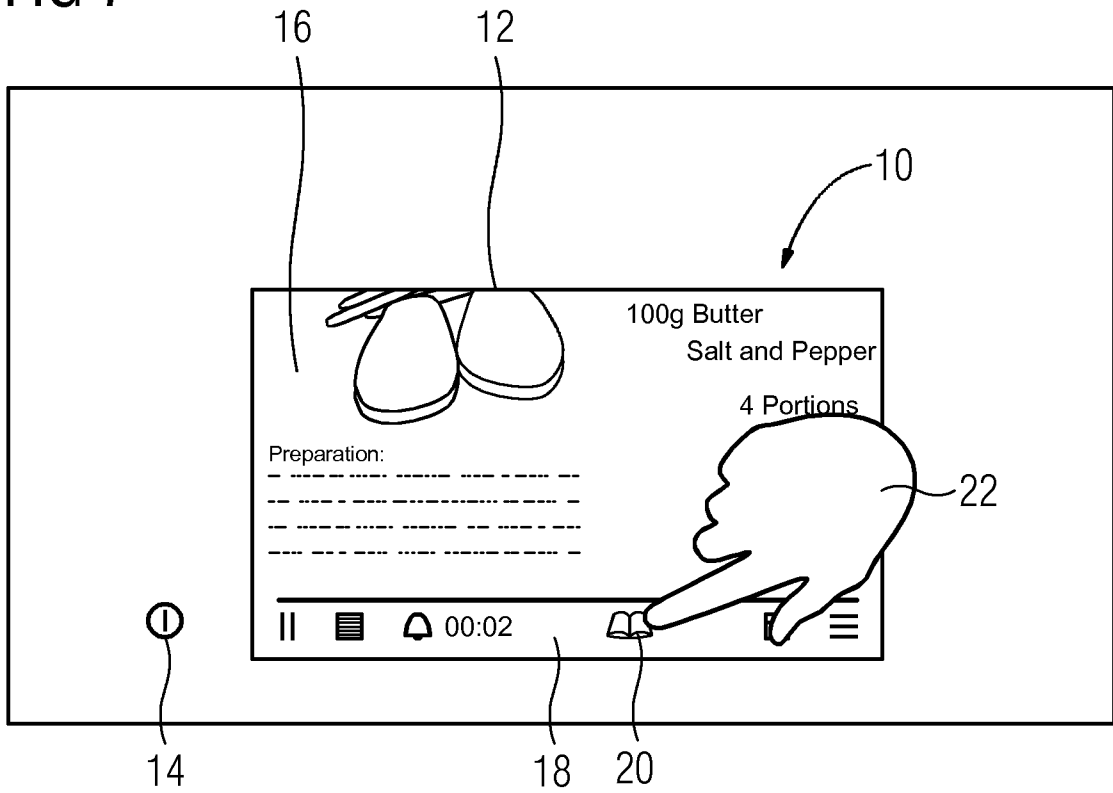

FIG 8

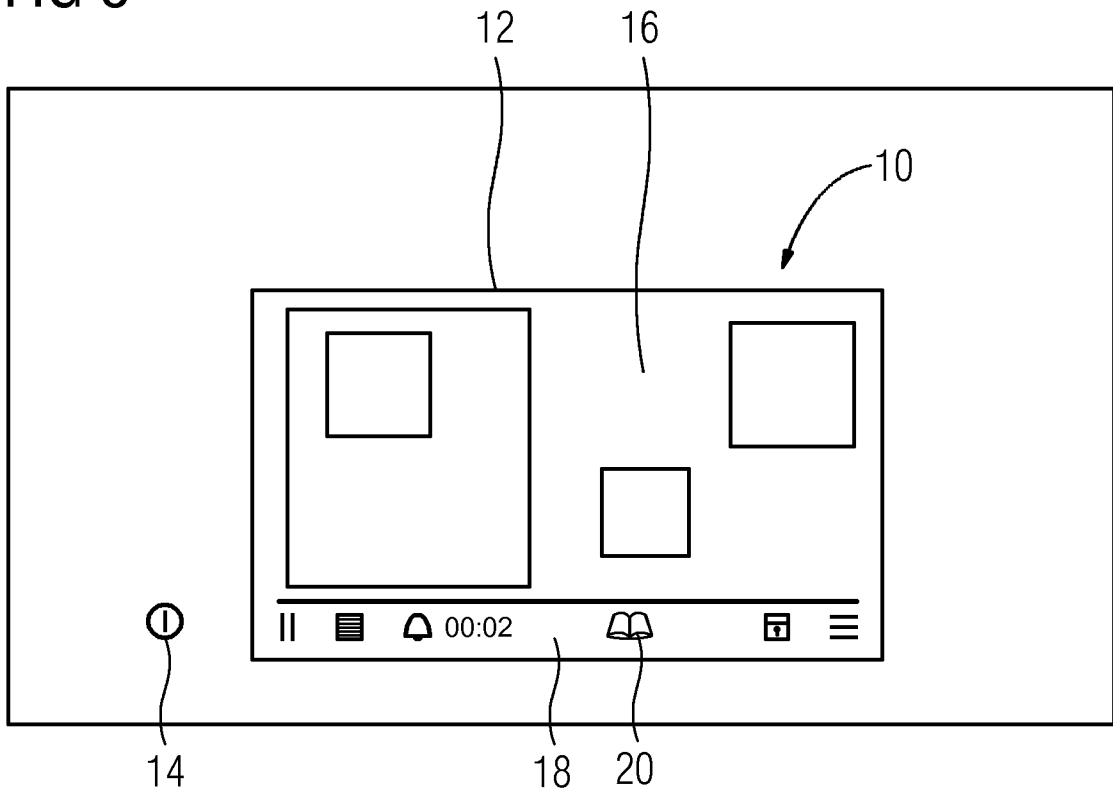

FIG 9

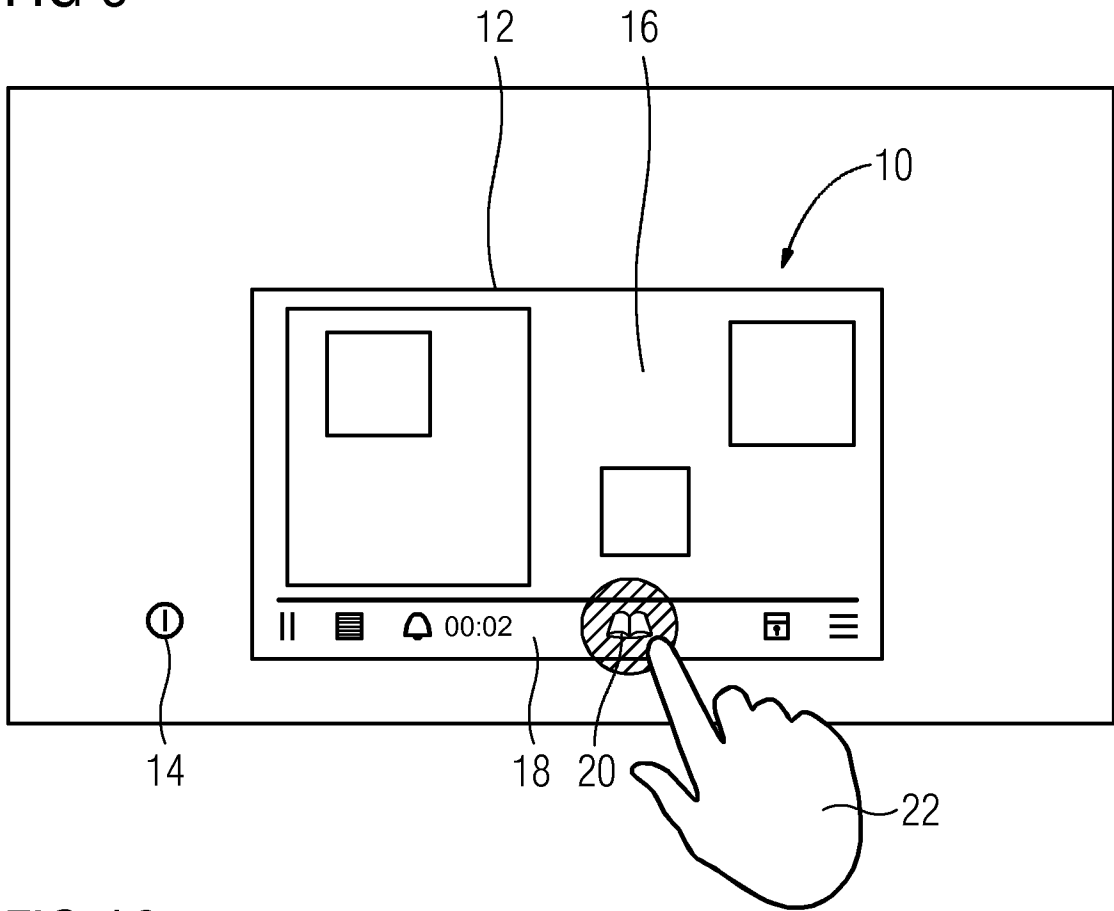
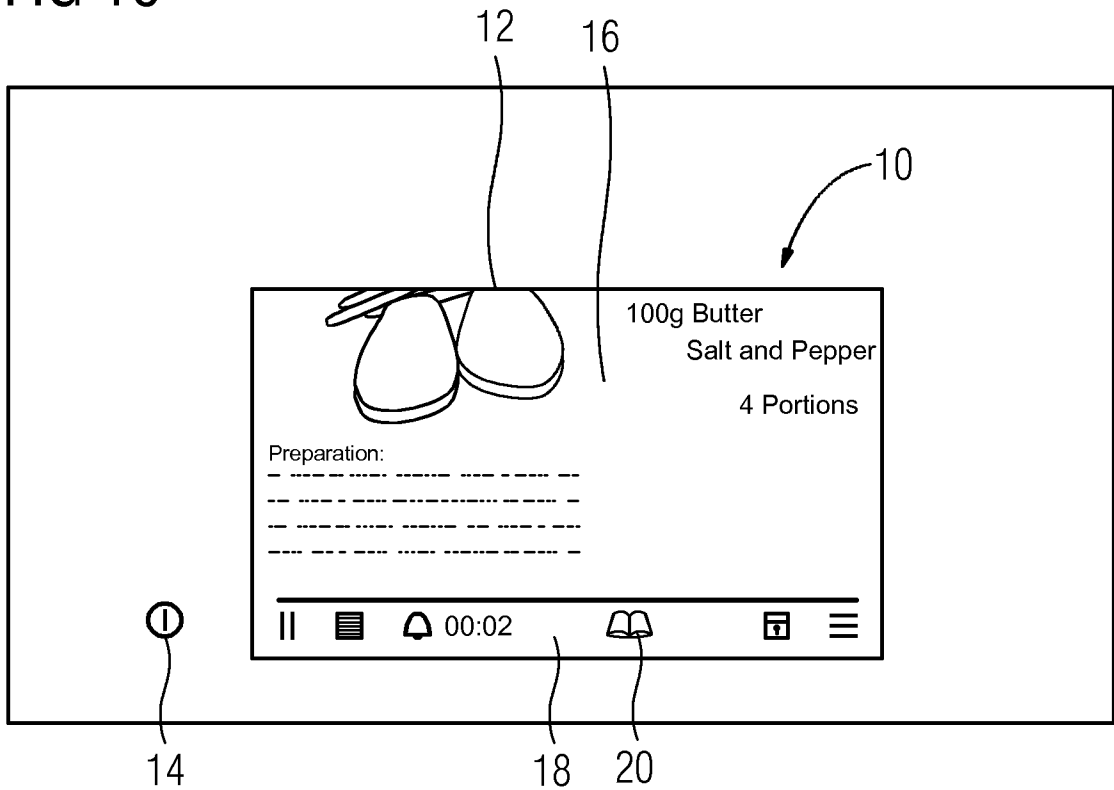

FIG 10



INTERNATIONAL SEARCH REPORT

International application No
PCT/EP2016/063321

A. CLASSIFICATION OF SUBJECT MATTER
INV. F24C7/08 G06F3/041
ADD.
According to International Patent Classification (IPC) or to both national classification and IPC

B. FIELDS SEARCHED
Minimum documentation searched (classification system followed by classification symbols)
F24C G06F
Documentation searched other than minimum documentation to the extent that such documents are included in the fields searched

Electronic data base consulted during the international search (name of data base and, where practicable, search terms used)
EPO-Internal, WPI Data

C. DOCUMENTS CONSIDERED TO BE RELEVANT		
Category*	Citation of document, with indication, where appropriate, of the relevant passages	Relevant to claim No.
X	US 2015/192302 A1 (ORTNER MATTHEW [US] ET AL) 9 July 2015 (2015-07-09)	1-6, 8-10,12, 14,15 7,11,13
Y	paragraphs [0019], [0020], [0024], [0029], [0032], [0040]; figures 1,3,5-8,9b	
X	US 2014/201664 A1 (GUILLEMINOT RAPHAEL [US] ET AL) 17 July 2014 (2014-07-17) figure 1	1,2,4-6, 12,14,15
Y	EP 2 211 117 A1 (RATIONAL AG [DE]) 28 July 2010 (2010-07-28) paragraph [0043]	
Y	DE 10 2008 032452 A1 (RATIONAL AG [DE]) 14 January 2010 (2010-01-14) paragraph [0042]	7
	----- -/--	7

Further documents are listed in the continuation of Box C.

See patent family annex.

* Special categories of cited documents :

<p>"A" document defining the general state of the art which is not considered to be of particular relevance</p> <p>"E" earlier application or patent but published on or after the international filing date</p> <p>"L" document which may throw doubts on priority claim(s) or which is cited to establish the publication date of another citation or other special reason (as specified)</p> <p>"O" document referring to an oral disclosure, use, exhibition or other means</p> <p>"P" document published prior to the international filing date but later than the priority date claimed</p>	<p>"T" later document published after the international filing date or priority date and not in conflict with the application but cited to understand the principle or theory underlying the invention</p> <p>"X" document of particular relevance; the claimed invention cannot be considered novel or cannot be considered to involve an inventive step when the document is taken alone</p> <p>"Y" document of particular relevance; the claimed invention cannot be considered to involve an inventive step when the document is combined with one or more other such documents, such combination being obvious to a person skilled in the art</p> <p>"&" document member of the same patent family</p>
---	---

Date of the actual completion of the international search 10 November 2016	Date of mailing of the international search report 28/11/2016
Name and mailing address of the ISA/ European Patent Office, P.B. 5818 Patentlaan 2 NL - 2280 HV Rijswijk Tel. (+31-70) 340-2040, Fax: (+31-70) 340-3016	Authorized officer Verdoodt, Luk

INTERNATIONAL SEARCH REPORT

International application No
PCT/EP2016/063321

C(Continuation). DOCUMENTS CONSIDERED TO BE RELEVANT		
Category*	Citation of document, with indication, where appropriate, of the relevant passages	Relevant to claim No.
Y	US 2007/062739 A1 (PHILIPP HARALD [GB] ET AL) 22 March 2007 (2007-03-22) paragraph [0070]; figure 7 -----	11
Y	EP 2 573 470 A2 (SAMSUNG ELECTRONICS CO LTD [KR]) 27 March 2013 (2013-03-27) paragraph [0086]; figures 1,14A -----	13

INTERNATIONAL SEARCH REPORT

Information on patent family members

International application No PCT/EP2016/063321

Patent document cited in search report	Publication date	Publication date	Patent family member(s)	Publication date
US 2015192302	A1	09-07-2015	NONE	

US 2014201664	A1	17-07-2014	NONE	

EP 2211117	A1	28-07-2010	CN 102356280 A	15-02-2012
			EP 2211117 A1	28-07-2010
			EP 2391851 A1	07-12-2011
			US 2012003364 A1	05-01-2012
			WO 2010086340 A1	05-08-2010

DE 102008032452	A1	14-01-2010	NONE	

US 2007062739	A1	22-03-2007	US 2007062739 A1	22-03-2007
			US 2011199333 A1	18-08-2011

EP 2573470	A2	27-03-2013	CN 102980217 A	20-03-2013
			EP 2573470 A2	27-03-2013
			KR 20130025502 A	12-03-2013
			US 2013056457 A1	07-03-2013
