



- (51) **International Patent Classification:**
E21B 7/08 (2006.01) *E21B 7/06* (2006.01)
E21B 29/06 (2006.01)
- (21) **International Application Number:** PCT/US2012/035754
- (22) **International Filing Date:** 30 April 2012 (30.04.2012)
- (25) **Filing Language:** English
- (26) **Publication Language:** English
- (71) **Applicant (for all designated States except US):** HAL-LIBURTON ENERGY SERVICES, INC. [US/US]; 10200 Bellaire Boulevard, Houston, TX 77072 (US).
- (72) **Inventors; and**
- (75) **Inventors/Applicants (for US only):** DANCER, William, Wallace [US/US]; 2720 Saddlehorn Dr., Denton, TX 75068 (US). DONOVAN, Stacey, Blaine [US/US]; 2120 Pacino Dr., Fort Worth, TX 76134 (US).
- (74) **Agent:** KAISER, Iona, N.; McDermott Will & Emery LLP, The McDermott Building, 500 North Capitol Street, N.W., Washington, DC 20001 (US).
- (81) **Designated States (unless otherwise indicated, for every kind of national protection available):** AE, AG, AL, AM, AO, AT, AU, AZ, BA, BB, BG, BH, BR, BW, BY, BZ, CA, CH, CL, CN, CO, CR, CU, CZ, DE, DK, DM, DO, DZ, EC, EE, EG, ES, FI, GB, GD, GE, GH, GM, GT, HN, HR, HU, ID, IL, IN, IS, JP, KE, KG, KM, KN, KP, KR, KZ, LA, LC, LK, LR, LS, LT, LU, LY, MA, MD, ME, MG, MK, MN, MW, MX, MY, MZ, NA, NG, NI, NO, NZ, OM, PE, PG, PH, PL, PT, QA, RO, RS, RU, RW, SC, SD, SE, SG, SK, SL, SM, ST, SV, SY, TH, TJ, TM, TN, TR, TT, TZ, UA, UG, US, UZ, VC, VN, ZA, ZM, ZW.
- (84) **Designated States (unless otherwise indicated, for every kind of regional protection available):** ARIPO (BW, GH, GM, KE, LR, LS, MW, MZ, NA, RW, SD, SL, SZ, TZ, UG, ZM, ZW), Eurasian (AM, AZ, BY, KG, KZ, RU, TJ, TM), European (AL, AT, BE, BG, CH, CY, CZ, DE, DK, EE, ES, FI, FR, GB, GR, HR, HU, IE, IS, IT, LT, LU, LV, MC, MK, MT, NL, NO, PL, PT, RO, RS, SE, SI, SK, SM, TR), OAPI (BF, BJ, CF, CG, CI, CM, GA, GN, GQ, GW, ML, MR, NE, SN, TD, TG).
- Published:**
— with international search report (Art. 21(3))

(54) **Title:** WELLBORE CASING SECTION WITH MOVEABLE PORTION FOR PROVIDING A CASING EXIT

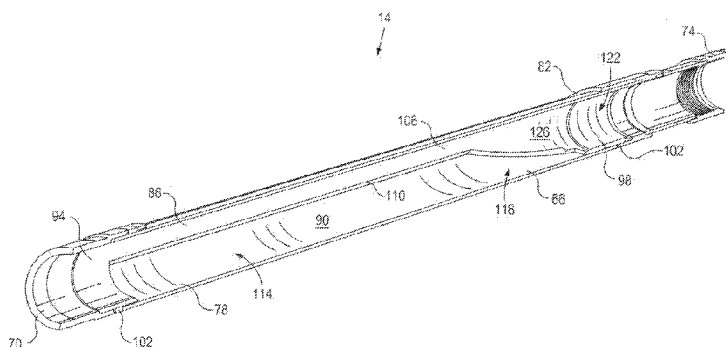

FIG. 3

(57) **Abstract:** Systems and methods for providing a casing exit include a casing section having a generally cylindrical outer sleeve including a proximal end and a distal end. The outer sleeve may define an outer window extending between the proximal end and the distal end. A generally cylindrical inner sleeve may be received within the outer sleeve and may define an inner window. The inner sleeve may be moveable between a first position in which the inner window is misaligned with the outer window and the inner sleeve substantially closes the outer window, and a second position in which the inner window is aligned with the outer window. A deflector tool may be configured to engage the inner sleeve and move the inner sleeve from the first position to the second position



WELLBORE CASING SECTION WITH MOVEABLE PORTION FOR PROVIDING A CASING EXIT

BACKGROUND

5 **[0001]** The present invention relates generally to providing a casing exit for a lateral borehole, and more particularly to systems and methods for providing a casing exit with little or no milling of the casing.

[0002] Hydrocarbons can be produced through relatively complex wellbores traversing a subterranean formation. Some wellbores can include
10 multilateral wellbores and/or sidetrack wellbores. Multilateral wellbores include one or more lateral wellbores extending from a parent (or main) wellbore. A sidetrack wellbore is a wellbore that is diverted from a first general direction to a second general direction. A sidetrack wellbore can include a main wellbore in a first general direction and a secondary wellbore diverted from the main wellbore
15 in a second general direction. A multilateral wellbore can include one or more windows or casing exits to allow corresponding lateral wellbores to be formed. A sidetrack wellbore can also include a window or casing exit to allow the wellbore to be diverted to the second general direction.

[0003] The casing exit for either multilateral or sidetrack wellbores can
20 be formed by positioning a casing joint and a whipstock in a casing string at a desired location in the main wellbore. The whipstock is used to deflect one or more mills laterally (or in an alternative orientation) relative to the casing string. The deflected mill(s) machines away and eventually penetrates part of the casing joint to form the casing exit in the casing string. Drill bits can be
25 subsequently inserted through the casing exit in order to cut the lateral or secondary wellbore.

[0004] Milling the casing exit is a time consuming and potentially harmful process. Milling away the material of the casing creates highly abrasive metallic chips that can cause significant wear on equipment located in the
30 wellbore during the milling process and on equipment that subsequently passes through the area in which the milling takes place. Furthermore, because the mill is only used for milling the casing exit, several trips down the wellbore are required before commencing actual drilling of the associated lateral wellbore.

SUMMARY OF THE INVENTION

[0005] The present invention relates generally to providing a casing exit for a lateral borehole, and more particularly to systems and methods for providing a casing exit with little or no milling of the casing.

5 **[0006]** In some embodiments, a casing section is disclosed for positioning in a wellbore at a location where it is desired to form a diverging lateral borehole. The casing section may include a generally cylindrical outer sleeve including a proximal end and a distal end. The outer sleeve may define an outer window extending between the proximal end and the distal end. A
10 generally cylindrical inner sleeve may be received within the outer sleeve and may define an inner window. The inner sleeve may be moveable between a first position in which the inner window is misaligned with the outer window and the inner sleeve substantially closes the outer window, and a second position in which the inner window is aligned with the outer window.

15 **[0007]** In other embodiments, a drilling system is disclosed for forming a lateral borehole that diverges away from a wellbore. The drilling system may include a casing string extended within the wellbore and including a casing section having an outer sleeve and an inner sleeve rotatably received within the outer sleeve. The outer sleeve may include an outer sleeve wall defining an
20 outer window that opens into the wellbore. The inner sleeve may include an inner sleeve wall defining an inner window. The inner sleeve may be rotatable with respect to the outer sleeve from a closed configuration in which the inner window is rotationally misaligned with the outer window and the inner sleeve wall substantially closes the outer window, to an open configuration in which the
25 inner window is substantially rotationally aligned with the outer window. The inner sleeve may include a first alignment portion engageable to rotate the inner sleeve with respect to the outer sleeve. A deflector tool may be positionable at least partially within the casing section. The deflector tool may include a deflector surface and a second alignment portion engageable with the first
30 alignment portion to rotate the inner sleeve to the open configuration.

[0008] In still other embodiments, a method is disclosed for providing a window in a casing string at a location within a wellbore. The method may include configuring a casing section having an outer sleeve defining an outer window and an inner sleeve defining an inner window in a closed configuration
35 whereby the inner window is rotationally misaligned with the outer window such

that the outer window is substantially closed by the inner sleeve. With the casing section in the closed configuration, the casing section may be positioned at the location within the wellbore. The inner sleeve may be rotated with respect to the outer sleeve to move the inner window into alignment with the outer window.

[0009] The features and advantages of the present invention will be readily apparent to those skilled in the art upon a reading of the description of the preferred embodiments that follows.

BRIEF DESCRIPTION OF THE DRAWINGS

[0010] The following figures are included to illustrate certain aspects of the present invention, and should not be viewed as exclusive embodiments. The subject matter disclosed is capable of considerable modifications, alterations, combinations, and equivalents in form and function, as will occur to those skilled in the art and having the benefit of this disclosure.

[0011] Fig. 1 is a schematic illustration of an offshore oil and gas platform using an exemplary rotatable window casing, according to one or more embodiments disclosed.

[0012] Fig. 2 is a perspective view of the rotatable window casing of Fig. 1 in a closed configuration.

[0013] Fig. 3 is a section view taken along line 3 – 3 of Fig. 2.

[0014] Fig. 4 is a section view taken along line 4 – 4 of Fig. 2.

[0015] Fig. 5 is an enlarged perspective view showing an alignment portion of an inner sleeve of the rotatable window casing of Fig. 2.

[0016] Fig. 6 is a perspective view of the rotatable window casing of Fig. 2 in an open configuration.

[0017] Fig. 7 is a section view taken along line 7 – 7 of Fig. 6.

[0018] Fig. 8 is an enlarged section view similar to Fig. 3 with the rotatable window casing in the open configuration and showing the alignment portion of Fig. 4.

[0019] Fig. 9 is a perspective view of a deflector tool configured for use with the offshore oil and gas platform of Fig. 1 and the rotatable window casing of Fig. 2.

[0020] Fig. 10 is an enlarged perspective view of a portion of the deflector tool of Fig. 9.

[0021] Fig. 11 is a perspective view showing the rotatable window casing of Fig. 2 in partial section, in the closed configuration, and with the deflector tool of Fig. 5 inserted therein.

5 [0022] Fig. 12 is a perspective view similar to Fig. 11 where the deflector tool has been rotated and latched into position and the rotatable window casing has been moved from the closed configuration to the open configuration.

10 [0023] Fig. 13 is a perspective view showing the rotatable window casing of Fig. 2 in the open configuration with the deflector tool of Fig. 9 latched into position.

DETAILED DESCRIPTION

15 [0024] The present invention relates generally to providing a casing exit for a lateral borehole, and more particularly to systems and methods for providing a casing exit with little or no milling of the casing.

20 [0025] Referring to Fig. 1, illustrated is an offshore oil and gas platform 10 that uses an exemplary rotatable window casing section 14, according to one or more embodiments of the disclosure. Even though Fig. 1 depicts an offshore oil and gas platform 10, it will be appreciated by those skilled in the art that the exemplary rotatable window casing section 14, and its alternative embodiments disclosed herein, are equally well suited for use in or on other types of oil and gas rigs, such as land-based oil and gas rigs or any other location. The platform 10 may be a semi-submersible platform 18 centered over a submerged oil and gas formation 22 located below the sea floor 26. A subsea conduit 30 extends
25 from the deck 34 of the platform 18 to a wellhead installation 38 including one or more blowout preventers 42. The platform 18 has a hoisting apparatus 46 and a derrick 50 for raising and lowering pipe strings, such as a drill string 54.

30 [0026] As depicted, a main wellbore 58 has been drilled through the various earth strata, including the formation 22. The terms "parent" and "main" wellbore are used herein to designate a wellbore from which another wellbore is drilled. It is to be noted, however, that a parent or main wellbore does not necessarily extend directly to the earth's surface, but could instead be a branch of yet another wellbore. A casing string 52, including the rotatable window casing section 14, is at least partially cemented within the main wellbore 58.
35 The term "casing" is used herein to designate a tubular string used to line a

wellbore. Casing may actually be of the type known to those skilled in the art as "liner" and may be made of any material, such as steel or composite material and may be segmented or continuous, such as coiled tubing. The rotatable window casing section 14 forms part of the casing string 52 and is positioned
5 along the casing string 52 at a location where it is desired to create a lateral borehole or wellbore 64 (shown in phantom) that intersects the parent or main wellbore 58.

[0027] Referring also to Fig. 2, the casing section 14 includes a generally cylindrical outer sleeve 66 including a proximal end 70 that, in the
10 illustrated embodiment, is configured for coupling to uphole portions of the casing string 52, and a distal end 74. The distal end 74 may be coupled to additional downhole portions of the casing string 52 or may include a plug or other wellbore termination depending upon whether the main wellbore 58 continues beyond the casing section 14 or terminates substantially at the casing
15 section 14. The outer sleeve 66 may be formed by a generally cylindrical outer sleeve wall 78. The outer sleeve wall 78 may be formed of steel, aluminum, composites, combinations thereof, or substantially any other suitable material or combination of materials. Once the casing section 14 is properly located within the main wellbore 58, the outer sleeve wall 78 remains substantially fixed with
20 respect to the main wellbore 58. The outer sleeve wall 78 includes a pre-formed opening that defines an outer window 82. By "pre-formed" it is meant that the opening that defines the outer window 82 is formed in the outer sleeve wall 78 before the casing section 14 is introduced into the wellbore. In the illustrated embodiment, the outer window 82 is substantially rectangular and arcuate and
25 extends generally from the proximal end 70 to the distal end 74 of the casing section 14.

[0028] Referring also to Fig. 3, the casing section 14 also includes a generally cylindrical inner sleeve 86 that is moveably received within the outer sleeve 66. In the exemplary embodiment of the drawings, the inner sleeve 86 is
30 rotatable with respect to the outer sleeve 66. The inner sleeve 86 of the exemplary embodiment is closely received by and is in substantial mating engagement with an inner surface 90 of the outer sleeve wall 78. The inner sleeve 86 includes a proximal end 94 and a distal end 98 that are each rotatably coupled to the outer sleeve 66 by suitable seal and bearing assemblies 102. In
35 the illustrated embodiment the bearing assemblies 102 permit rotational

movement of the inner sleeve 86 with respect to the outer sleeve 66 while substantially preventing or limiting axial movement of the inner sleeve 86 with respect to the outer sleeve 66. In other embodiments, the inner sleeve 86 may also or alternatively be axially moveable with respect to the outer sleeve 66.

5 **[0029]** The inner sleeve 86 includes an inner sleeve wall 106. The inner sleeve wall 106 includes a pre-formed opening that defines an inner window 110. In the illustrated embodiment the inner window 110 includes a proximal portion 114 that is substantially rectangular and arcuate, and a tapered distal portion 118 having a substantially triangular or truncated triangular profile. It should be understood that the section view of Fig. 3 only shows substantially one-half of the inner window 110. Fig. 3 illustrates the casing section 14 in a first or closed configuration, where the inner window 110 does not communicate with or is otherwise not exposed to the outer window 82 (Fig. 2).

15 **[0030]** For instance, as further shown in Fig. 4, when the casing section 14 is in the closed configuration, the inner sleeve 86 is in a first position in which the inner window 110 is misaligned with the outer window 82 of the outer sleeve 66. In the illustrated embodiment, when the inner sleeve 86 is in the first position the inner window 110 is substantially diametrically opposed to the outer window 82. With the casing section 14 in the closed configuration, the inner sleeve 86, and more specifically the inner sleeve wall 106, underlies and substantially closes the outer window 82. Because the outer window 82 is closed by the inner sleeve wall 106, material and debris located outside of the casing section 14 is generally unable to pass into the interior of the casing section 14, and vice-versa.

25 **[0031]** During formation of the main wellbore 58 and assembly of the casing string 52, the casing section 14 may be inserted into the casing string 52 at a desired location and advanced into the wellbore while in the closed configuration. When the casing section 14 is in the closed configuration, it can function in substantially the same manner as an otherwise standard section of casing or tubing within the casing string 52, thereby allowing the drill string and other equipment to be moved along and through the length of the casing section 14 in a substantially unrestricted manner until such time as it is desired to form the lateral borehole or wellbore 64 (Fig. 1). The casing section 14 is inserted into the casing string 52 and advanced along the wellbore 58 until it is located at a desired intersection of the lateral borehole 64 and the main wellbore 58, at

which point the casing section 14 is cemented or otherwise secured within the wellbore 58.

[0032] Referring also to Fig. 5, the distal end 98 of the inner sleeve 86 includes an alignment portion 122 formed on an inner surface 126 of the inner sleeve wall 106. The illustrated alignment portion 122 may include an axially-extending slot 130 formed within a reduced-diameter portion 134 of the inner sleeve wall 106. Angled cam surfaces 138 may be positioned at a proximal end of the slot 130 and extend in a proximal and radial direction to function as alignment aids, as discussed further below. In other embodiments, the alignment portion 122 may be or include an aperture in the inner sleeve wall 106, a projection extending inwardly from the inner sleeve wall 106, a curved slot or curved projection that defines a more elongated cam surface 138, combinations thereof, and the like. Moreover, in still other embodiments the alignment portion 122 may be located at the proximal end 94 of the inner sleeve 86, or at substantially any location along the length of the inner sleeve 86.

[0033] Referring now to Figs. 6 through 8, the inner sleeve 86 is moveable, for example rotatable, with respect to the outer sleeve 66 from the first position of Figs. 2 through 4 in which the inner window 110 is misaligned with the outer window 82 to a second position shown in Figs. 5 through 7 in which the inner window 110 is substantially aligned with the outer window 82. When the inner sleeve 86 is in the second position, the casing section 14 is in a second, open configuration whereby the interior of the casing section 14 is exposed or opened to the exterior of the casing section 14. In this way, tools and other equipment can be guided or diverted out of the main wellbore and against the now exposed inner surface of the main wellbore 58 (see Fig. 1), for example to cut or otherwise form a lateral or secondary borehole or wellbore 64 that diverges away from the main wellbore 58. As shown, the size and shape of the inner window 110 is substantially similar to and generally compliments the size and shape of the outer window 82 to provide an elongated window or casing exit that extends along a substantial majority of the casing section 14. Generally speaking, the sizes of the inner window and the outer window 82 will be determined by the size of the system and the outer diameters of the mills and/or drill bits used to form the lateral wellbore 64. For example, a chord length L_i (Figs. 4 and 7) of the inner opening should be larger than the outer diameter of the largest mill or drill bit that will be used to form the lateral

wellbore, and a chord length L_o (Figs. 4 and 7) of the outer opening should be slightly larger than the chord length L_i .

[0034] To move the inner sleeve 86 from the first position in which the casing section 14 is in the closed configuration to the second position in which the casing section 14 is in the open configuration, suitably configured equipment may be run down the casing string 52 to the casing section 14. Such equipment is provided with an alignment feature configured to engage with the alignment portion 122 provided on the inner sleeve 86. The equipment is then operated to apply a force to the alignment portion 122 that in turn causes movement, for example rotation, of the inner sleeve 86 with respect to the outer sleeve 66 until the inner sleeve 86 has been moved to the second position and the inner window 110 is brought into substantial alignment with the outer window 82.

[0035] Referring also to Fig. 9, although substantially any type of down hole equipment can be used to adjust the casing section 14 from the closed configuration to the open configuration, in the illustrated embodiment, a deflector tool 142 in the form of a whipstock assembly may be configured to engage the alignment portion 122 of the inner sleeve 86 and thereby move the inner sleeve 86 from the first position to the second position. It should be appreciated that deflector tools 142 other than the illustrated whipstock assembly, such as a completion deflector, or a combination deflector that incorporates both a whipstock face and a completion deflector into one deflector face can also be utilized in combination with the casing section 14 and the general teachings and concepts discussed herein. At least one advantage of using the deflector tool 142 to move the inner sleeve 86 is that once the inner sleeve 86 has been moved and the casing section 14 is in the open configuration, the deflector tool 142 is already in position to deflect additional drilling equipment through the opened outer window 82 to begin drilling the lateral borehole 64.

[0036] The deflector tool 142 includes a proximal portion 146 that includes an angled deflector surface 150, an intermediate portion including a second alignment portion or alignment section 154 configured to engage the alignment portion 122, and distal latching portion 158 for fixedly engaging the distal end 74 of the outer sleeve 66. As can be appreciated, the deflector tool 142 is sized and configured to fit within the casing section 14.

[0037] Referring also to Fig. 10, one exemplary embodiment of the alignment section 154 includes an elongated and radially outwardly extending projection or lug 162 sized and configured to fit within the slot 130 of the alignment portion 122 of the inner sleeve 86 (see Fig. 5). The lug 162 may include angled lead-in surfaces 166 at each end that cooperate with the cam surfaces 138 (Fig. 5) of the alignment portion 122 to aid in rotational alignment of the inner sleeve 86 with the deflector tool 142 as the deflector tool 142 is advanced into the casing section 14. As best shown in Fig. 9, the lug 162 extends radially in a direction that is substantially diametrically opposed to the direction in which the deflector surface 150 faces. In other embodiments, the configuration of components may be reversed such that the alignment portion 122 of the inner sleeve 86 includes the lug 162 and the alignment section 154 of the deflector tool 142 defines the slot 130. Still other embodiments may include a more extensive arrangement of cam surfaces on one or both of the alignment portion 122 and the alignment section 154 such that axial movement of the deflector tool 142 into the casing section 14 engages the cam surfaces and causes the inner sleeve 86 to rotate from the first position to the second position. In still other embodiments, the lug 162 may be moveable between an extended position similar to the position illustrated in Fig. 10, and a retracted position whereby the lug 162 is substantially flush with the surrounding surfaces of the deflector tool 142. In such embodiments, once the deflector tool 142 is advanced to an appropriate location in the casing section 14, the lug 162 could be extended for engagement with or fitment within a suitably configured alignment portion 122 provided on the inner sleeve 86.

[0038] Fig. 11 shows the deflector tool 142 axially advancing into the casing section 14 with the casing section 14 in the closed configuration. In the position shown, the lug 162 is still slightly uphole of the alignment portion 122 and the slot 130. The lug 162 is also substantially radially aligned with the location of the outer window 82 and substantially diametrically opposed with respect to the inner window 110. Although not shown, the deflector surface 150 is facing toward the inner window 110.

[0039] Referring now to Fig. 12, the deflector tool 142 has been axially advanced to insert the lug 162 into the slot 130 of the alignment portion 122. The deflector tool 142 has also been rotated about 180 degrees to move the inner sleeve 86 from the first position to the second position, thereby changing

the casing section 14 from the closed configuration to the open configuration. As shown, the inner window 110 has been brought into substantial alignment with the outer window 82, and the deflector surface 150 is facing through the now opened inner and outer windows 110, 82. In alternative embodiments, one
5 or both of the deflector tool 142 and the alignment portion 122 may be configured with an appropriate arrangement of cam surfaces such that as the deflector tool 142 is axially advanced into the alignment portion 122, the cam surfaces cause the inner sleeve 86 to rotate from the first position to the second position. In such alternative embodiments, the deflector tool 142 can be
10 advanced into the casing section 14 with the deflector surface 150 facing toward the outer window 82. Still other embodiments may rely on a combination of cam surfaces and rotation of the deflector tool 142 to fully rotate the inner sleeve 86 from the first position to the second position.

[0040] In addition, latching cleats 170 on the latching portion 158 have
15 been extended radially outwardly for engagement with the distal end 74 of the outer sleeve 66. In the illustrated embodiments, the latching cleats 170 may be extended after the deflector tool 142 has been rotated to move the inner sleeve 86 from the first position to the second position. In other embodiments the latching portion 158 may be rotatable with respect to the remainder of the
20 deflector tool 142, in which case the latching cleats 170 may optionally be extended after the deflector tool 142 has been advanced axially into the casing section, but before the deflector tool 142 is rotated to move the inner sleeve 110 to the second position.

[0041] Referring to Fig. 13, when the casing section 14 is in the open
25 configuration, the entire deflector surface 150 is substantially exposed to the exterior of the casing section 14. More specifically, the axial length of the inner and outer windows 110, 82 are greater than the axial length of the deflector surface 150. In this way, tools guided through the casing section 14 and into engagement with the deflector surface 150 may be diverted through the casing
30 exit defined by the inner and outer windows 110, 82 and against the interior surface of the main wellbore to form or enter into an already formed lateral wellbore.

[0042] Therefore, the present invention is well adapted to attain the
ends and advantages mentioned as well as those that are inherent therein. The
35 particular embodiments disclosed above are illustrative only, as the present

invention may be modified and practiced in different but equivalent manners apparent to those skilled in the art having the benefit of the teachings herein. Furthermore, no limitations are intended to the details of construction or design herein shown, other than as described in the claims below. It is therefore

5 evident that the particular illustrative embodiments disclosed above may be altered, combined, or modified and all such variations are considered within the scope and spirit of the present invention. The invention illustratively disclosed herein suitably may be practiced in the absence of any element that is not specifically disclosed herein and/or any optional element disclosed herein. While

10 compositions and methods are described in terms of "comprising," "containing," or "including" various components or steps, the compositions and methods can also "consist essentially of" or "consist of" the various components and steps. All numbers and ranges disclosed above may vary by some amount. Whenever a numerical range with a lower limit and an upper limit is disclosed, any number

15 and any included range falling within the range is specifically disclosed. In particular, every range of values (of the form, "from about a to about b," or, equivalently, "from approximately a to b," or, equivalently, "from approximately a-b") disclosed herein is to be understood to set forth every number and range encompassed within the broader range of values. Also, the terms in the claims

20 have their plain, ordinary meaning unless otherwise explicitly and clearly defined by the patentee. Moreover, the indefinite articles "a" or "an," as used in the claims, are defined herein to mean one or more than one of the element that it introduces. If there is any conflict in the usages of a word or term in this specification and one or more patent or other documents that may be

25 incorporated herein by reference, the definitions that are consistent with this specification should be adopted.

CLAIMS

The invention claimed is:

1. A casing section for positioning in a wellbore at a location where it is desired to form a diverging lateral borehole, the casing section comprising:

a generally cylindrical outer sleeve, the outer sleeve including a proximal end and a distal end, the outer sleeve defining an outer window extending between the proximal end and the distal end; and

a generally cylindrical inner sleeve received within the outer sleeve and defining an inner window, the inner sleeve being moveable between a first position in which the inner window is misaligned with the outer window and the inner sleeve substantially closes the outer window, and a second position in which the inner window is aligned with the outer window.

2. The casing section of claim 1, wherein the inner sleeve is rotatable with respect to the outer sleeve from the first position to the second position.

3. The casing section of claim 1, wherein the inner sleeve includes an alignment portion engageable to move the inner sleeve with respect to the outer sleeve.

4. The casing section of claim 3, wherein the alignment portion includes a slot.

5. The casing section of claim 3, wherein the alignment portion includes a cam surface extending in a proximal and radial direction.

6. The casing section of claim 1, wherein the outer sleeve includes a generally cylindrical outer sleeve wall, and wherein the outer window is defined by and extends through the outer sleeve wall.

7. The casing section of claim 1, wherein the inner sleeve includes a generally cylindrical inner sleeve wall, and wherein the inner window is defined by and extends through the inner sleeve wall.

8. The casing section of claim 1, wherein when the inner sleeve is moved to the second position, the outer window is opened and provides access to the wellbore for forming the diverging lateral borehole.

9. A drilling system for forming a lateral borehole that diverges away from a wellbore, the system comprising:

a casing string extended within the wellbore and including a casing section having an outer sleeve and an inner sleeve rotatably received within the outer sleeve, the outer sleeve including an outer sleeve wall defining an outer window that opens into the wellbore, the inner sleeve including an inner sleeve wall defining an inner window, the inner sleeve being rotatable with respect to the outer sleeve from a closed configuration in which the inner window is rotationally misaligned with the outer window and the inner sleeve wall substantially closes the outer window, to an open configuration in which the inner window is substantially rotationally aligned with the outer window, the inner sleeve including a first alignment portion engageable to rotate the inner sleeve with respect to the outer sleeve; and

a deflector tool positionable at least partially within the casing section, the deflector tool including a deflector surface and a second alignment portion engageable with the first alignment portion to rotate the inner sleeve to the open configuration.

10. The drilling system of claim 9, wherein, when the deflector tool is positioned in the casing section, the second alignment portion engages the first alignment portion to rotate the inner sleeve to the open configuration.

11. The drilling system of claim 9, wherein the inner sleeve is axially fixed with respect to the outer sleeve.

12. The drilling system of claim 9, wherein one of the first alignment portion and the second alignment portion includes a slot, and the other of the first alignment portion and the second alignment portion includes a projection.

13. The drilling system of claim 12, wherein the projection is moveable in a radial direction between an extended position and a retracted position.

14. The drilling system of claim 9, wherein the first alignment portion includes a cam surface extending in a proximal and radial direction.

15. The drilling system of claim 9, wherein when the second alignment portion engages the first alignment portion, rotation of the deflector tool causes rotation of the inner sleeve.

16. The drilling system of claim 9, wherein when the second alignment portion engages the first alignment portion, axial movement of the deflector tool causes rotation of the inner sleeve.

17. The drilling system of claim 9, wherein the second alignment portion is located distally of the deflector surface.

18. The drilling system of claim 9, wherein an axial length of the inner window is larger than an axial length of the deflector surface.

19. A method for providing a window in a casing string at a location within a wellbore, the method comprising:

configuring a casing section having an outer sleeve defining an outer window and an inner sleeve defining an inner window in a closed configuration whereby the inner window is rotationally misaligned with the outer window such that the outer window is substantially closed by the inner sleeve;

with the casing section in the closed configuration, positioning the casing section at the location within the wellbore; and,

rotating the inner sleeve with respect to the outer sleeve to move the inner window into alignment with the outer window.

20. The method of claim 19, further comprising locating a deflector tool within the casing section and engaging the inner sleeve with the deflector tool.

21. The method of claim 20, further comprising rotating the deflector tool to rotate the inner sleeve.

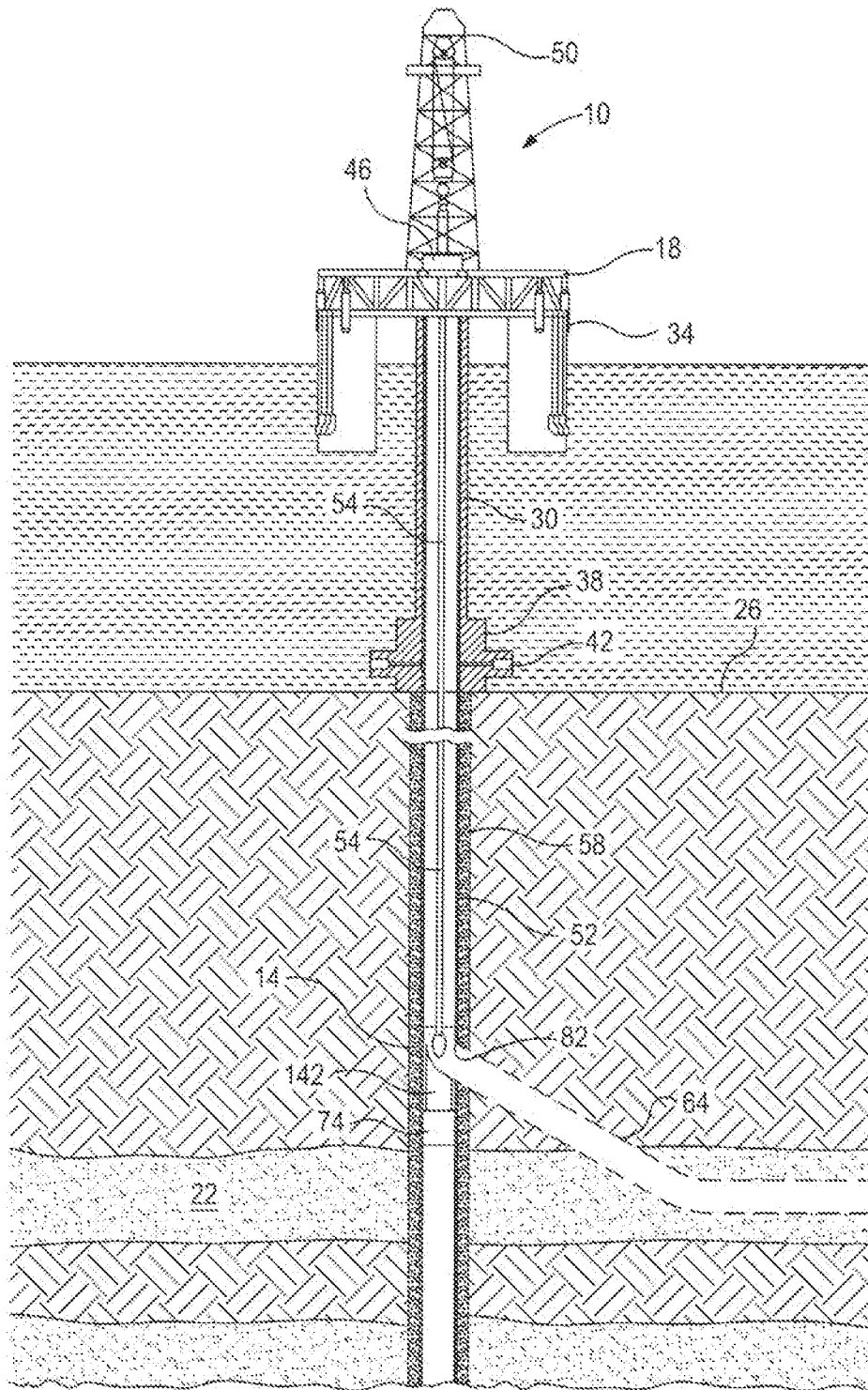

FIG. 1

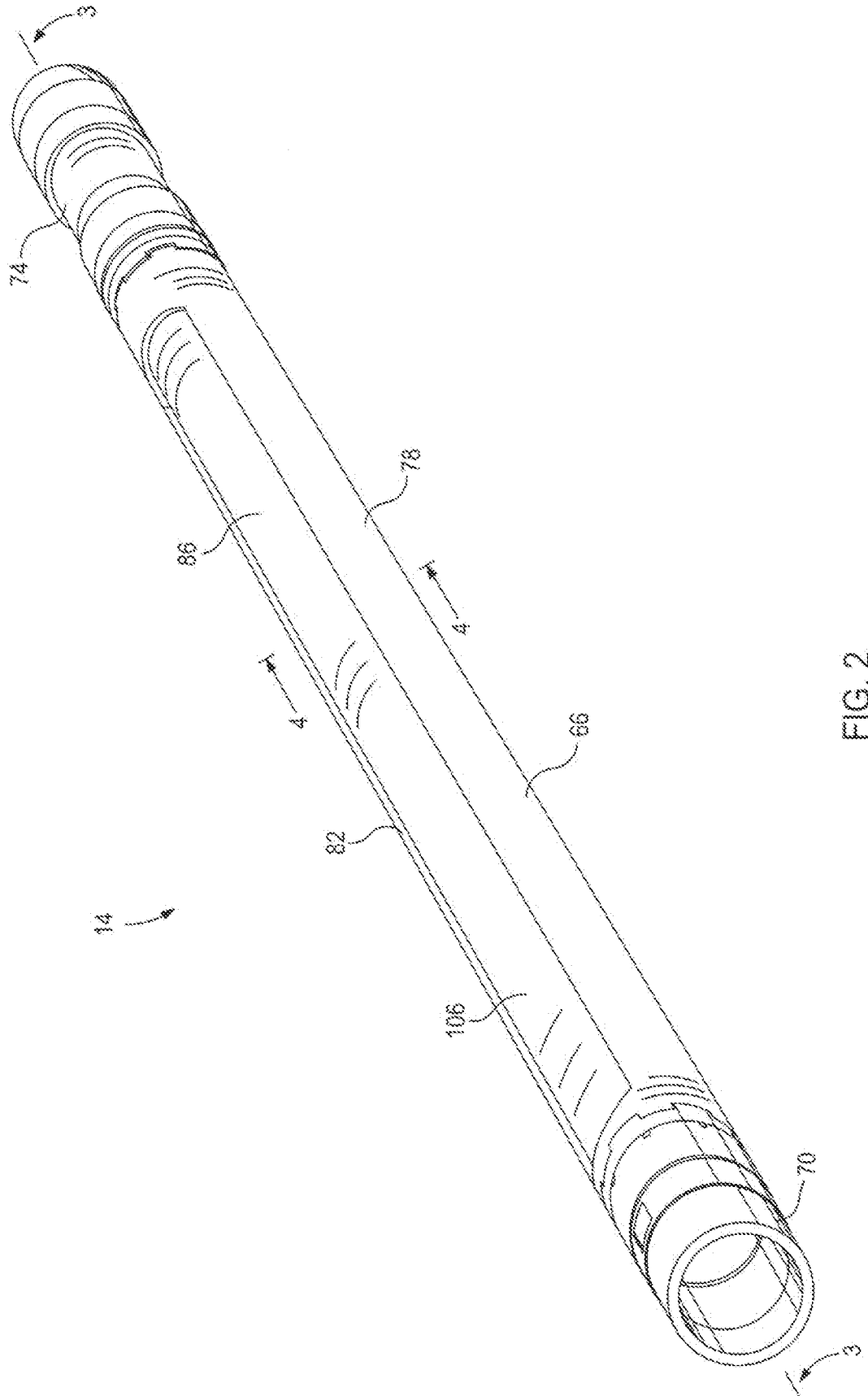

FIG. 2

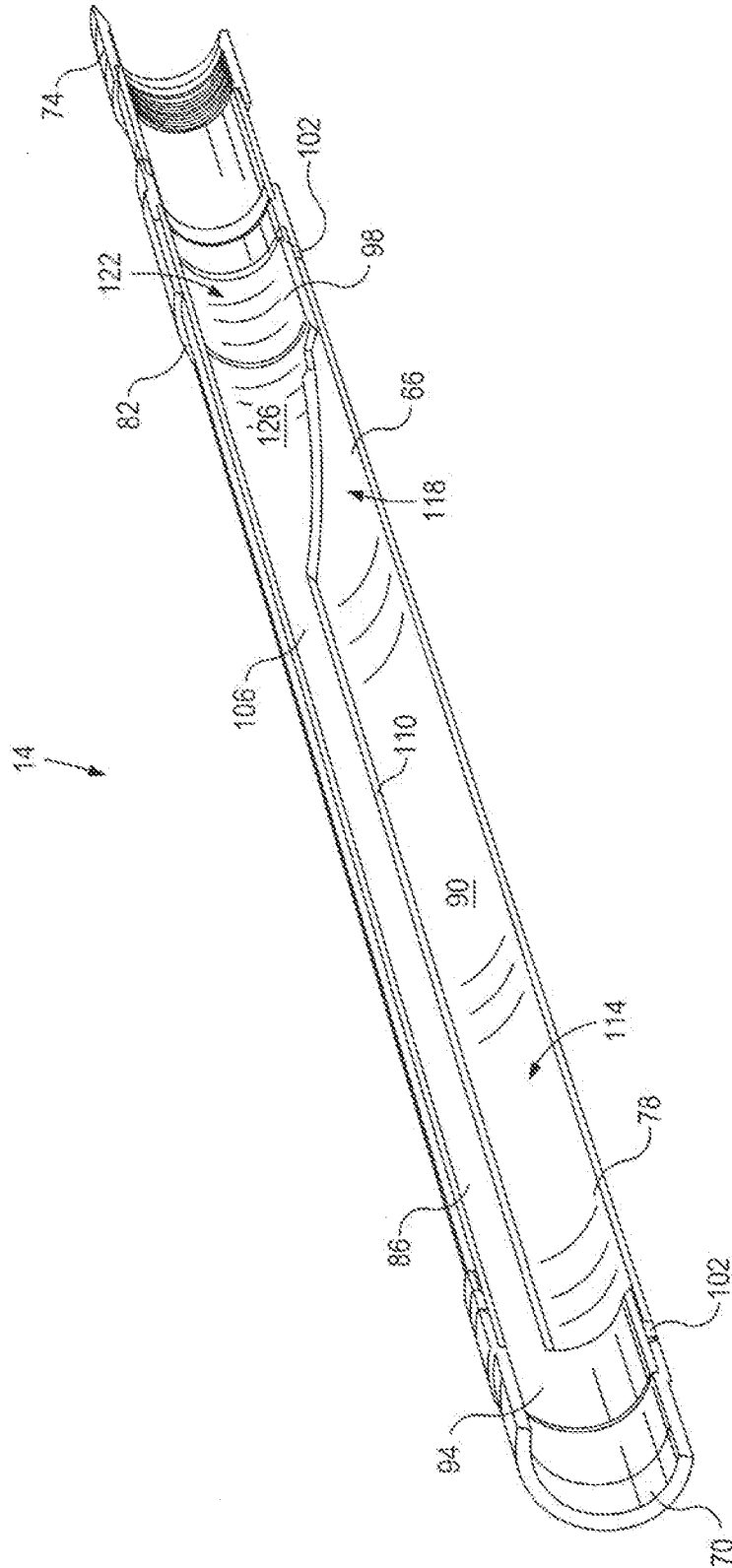

FIG. 3

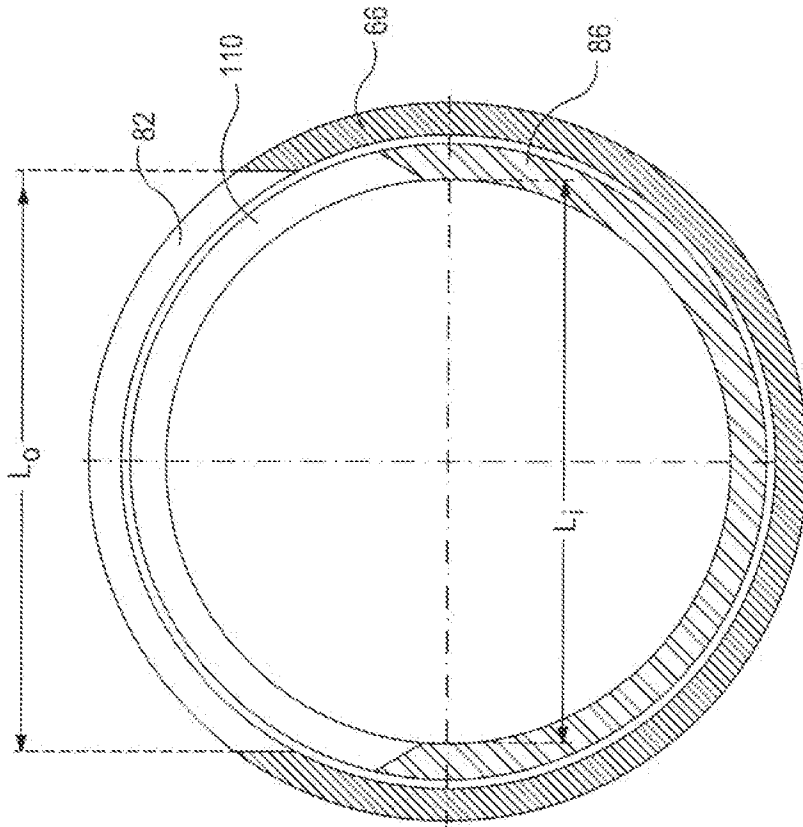

FIG. 7

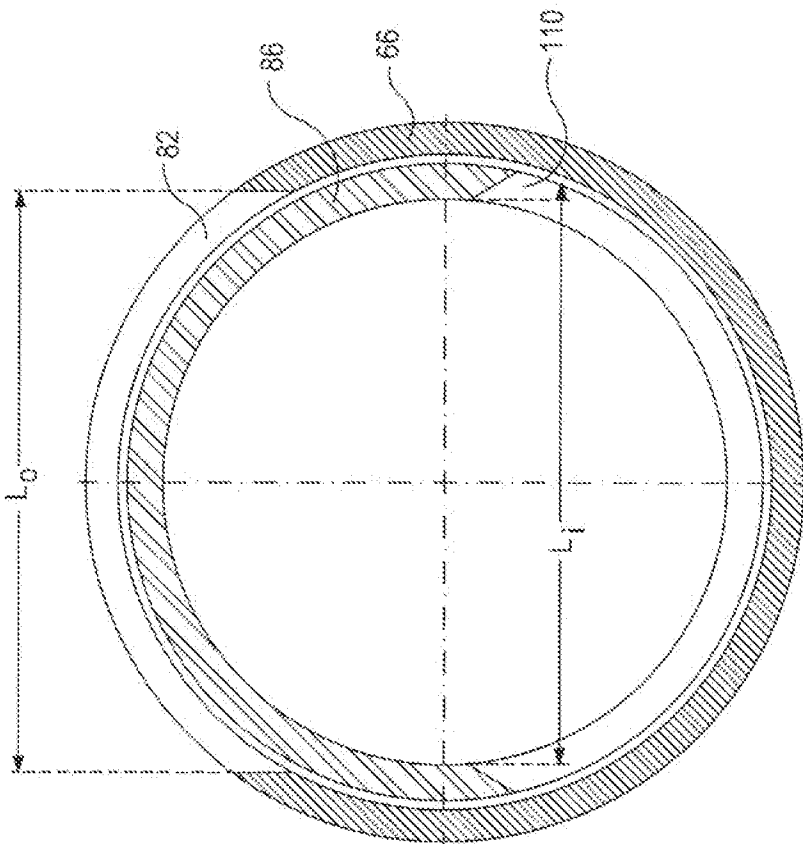

FIG. 4

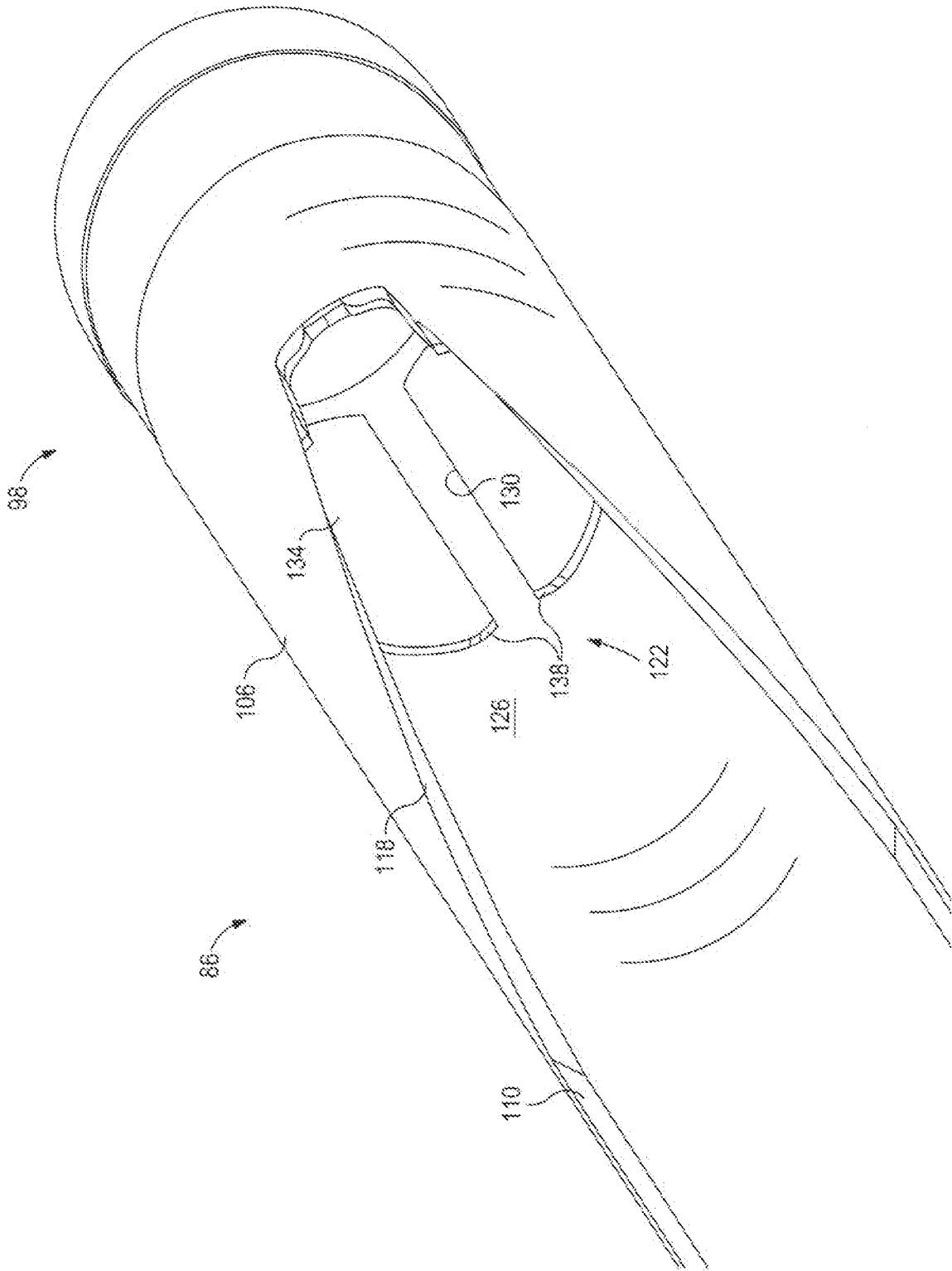

FIG. 5

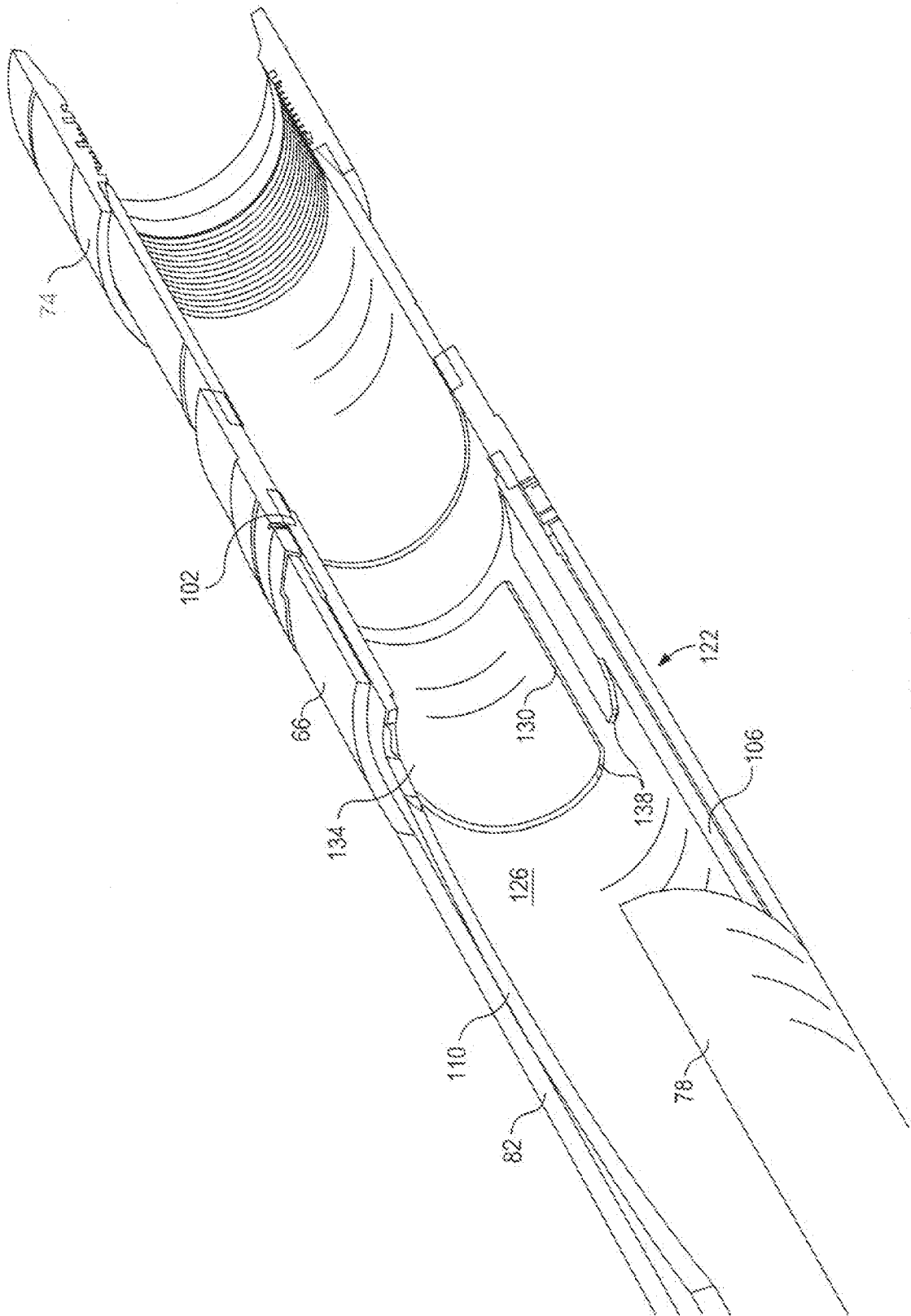

FIG. 8

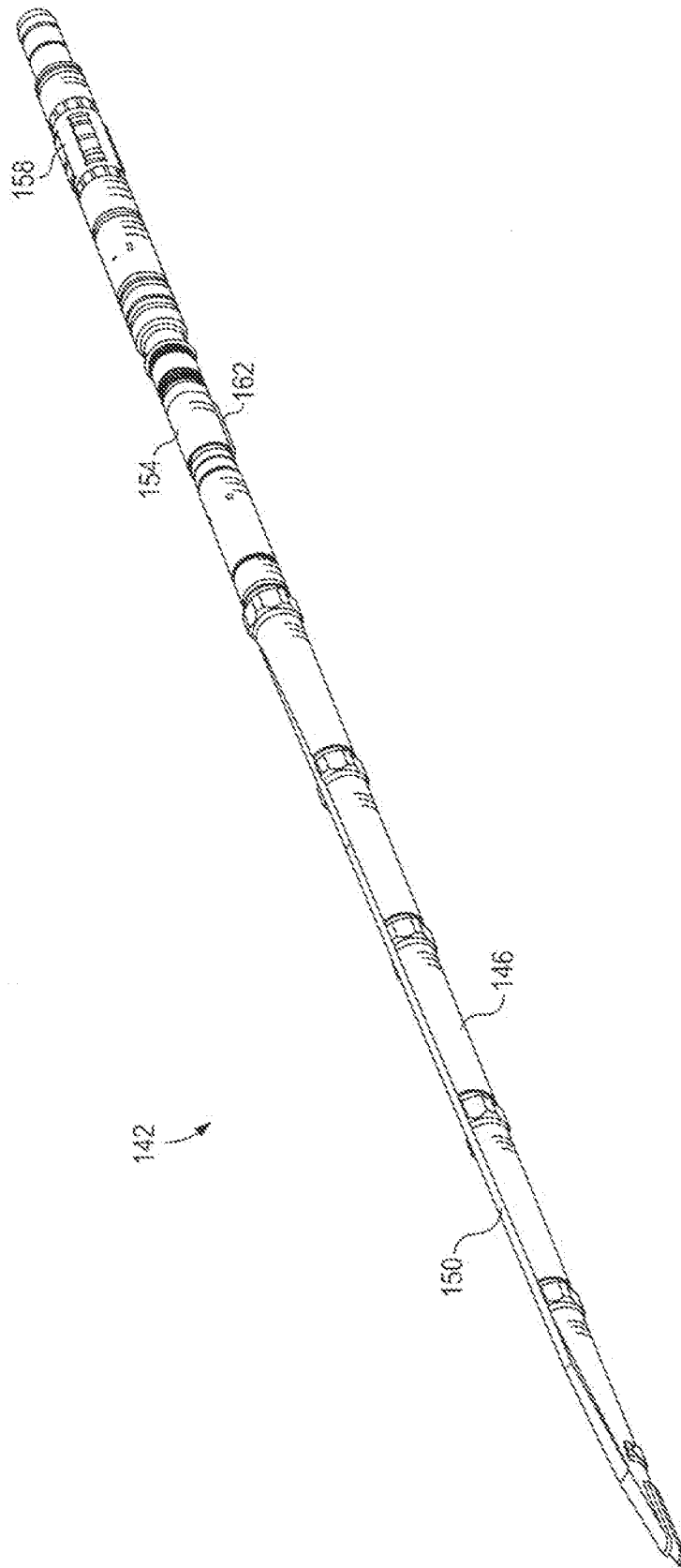

FIG. 9

9/12

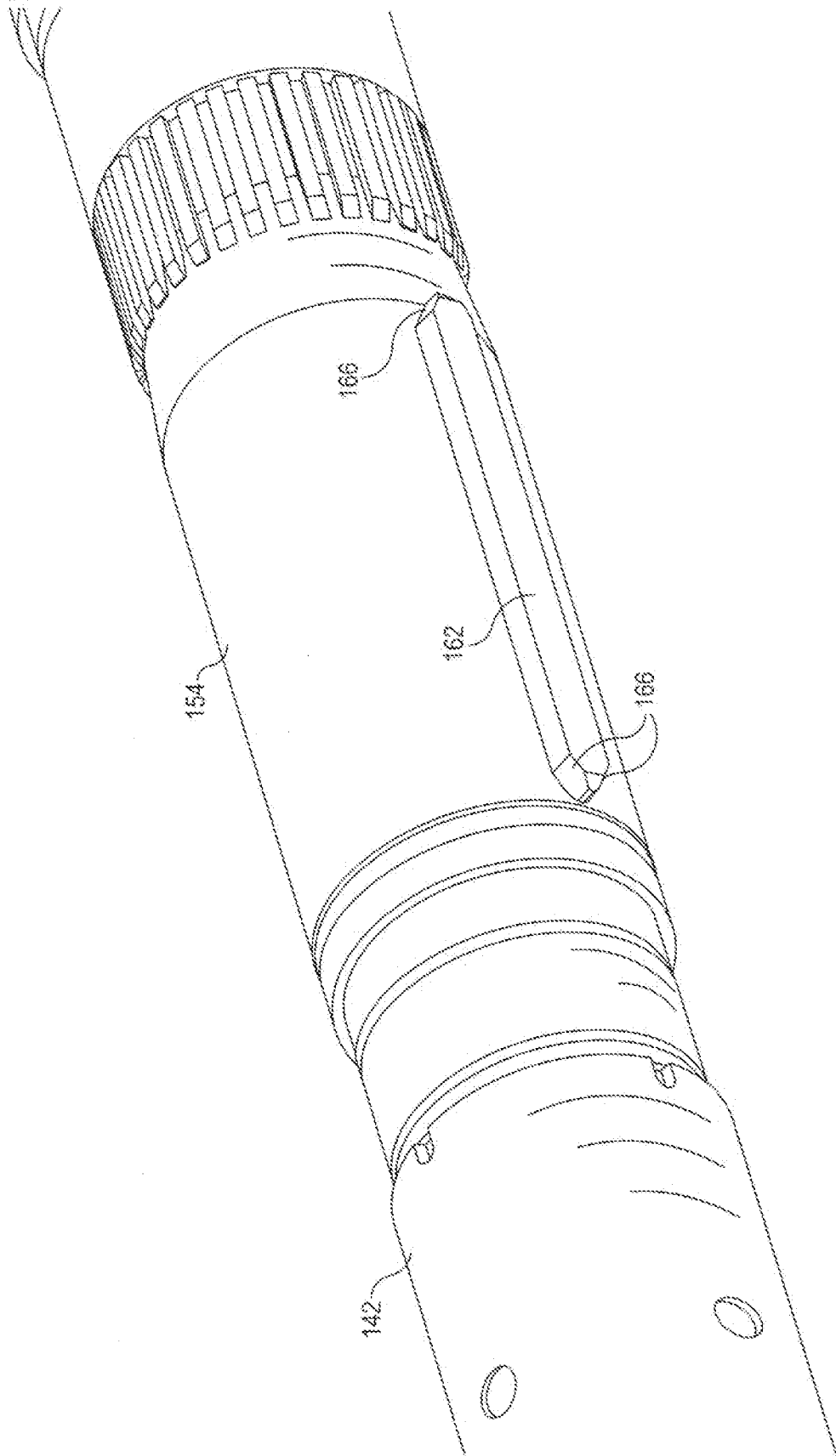

FIG. 10

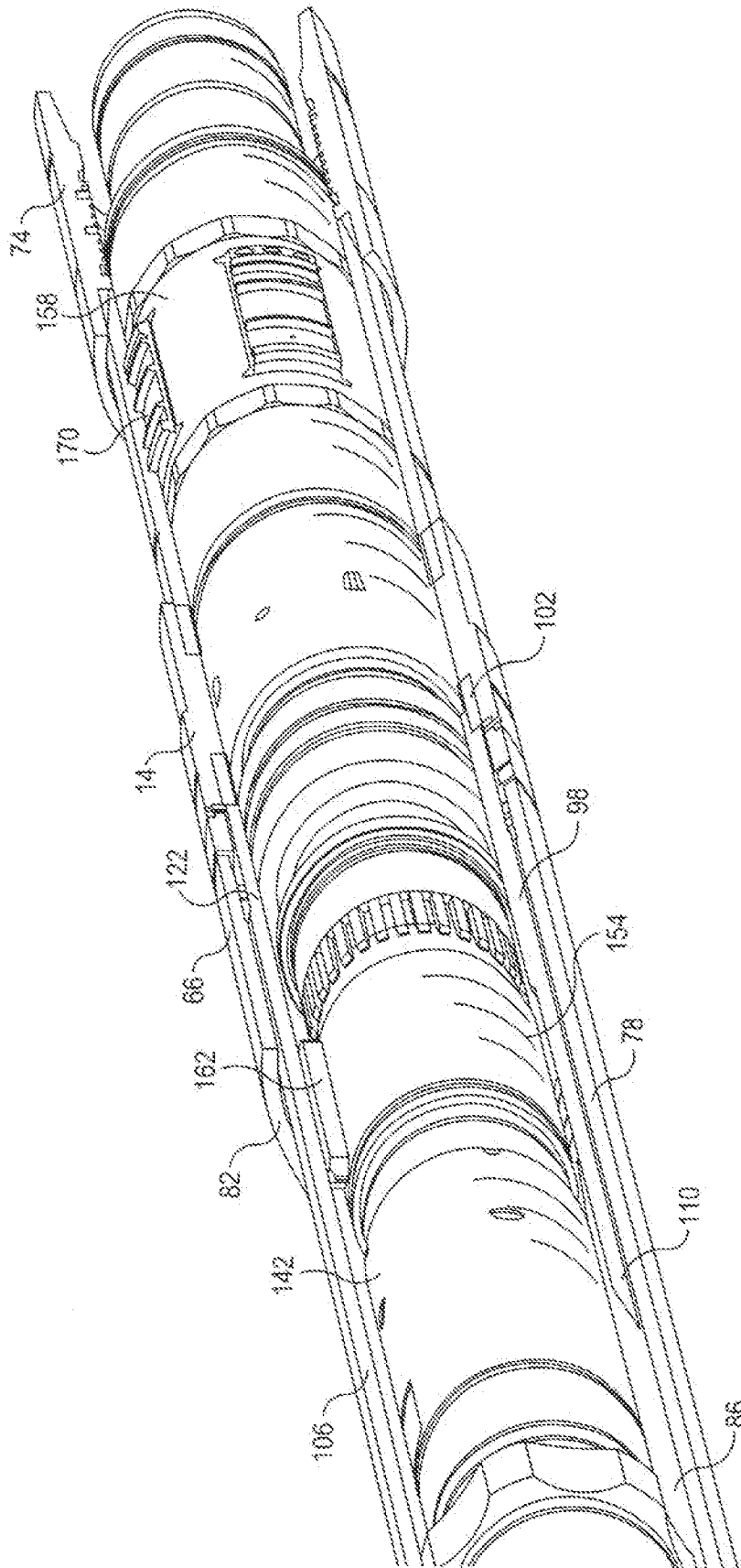

FIG. 11

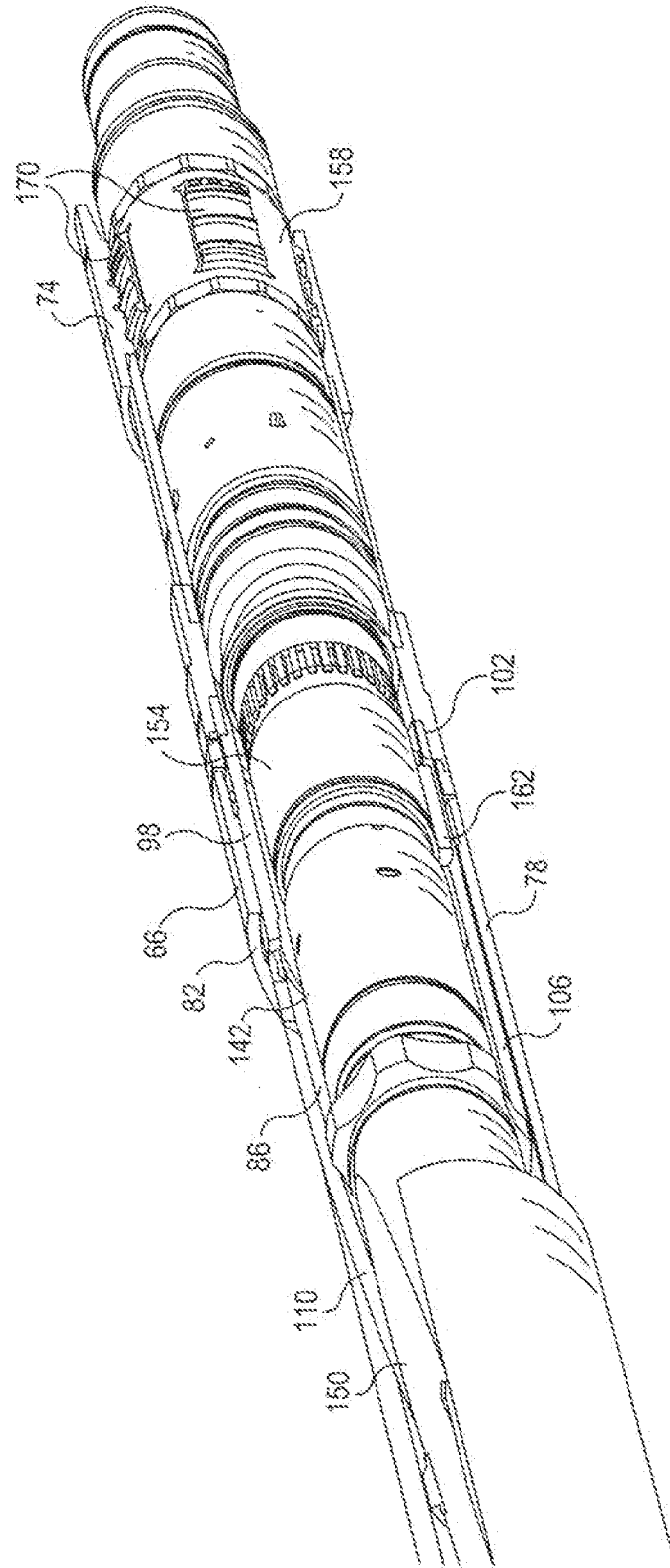

FIG. 12

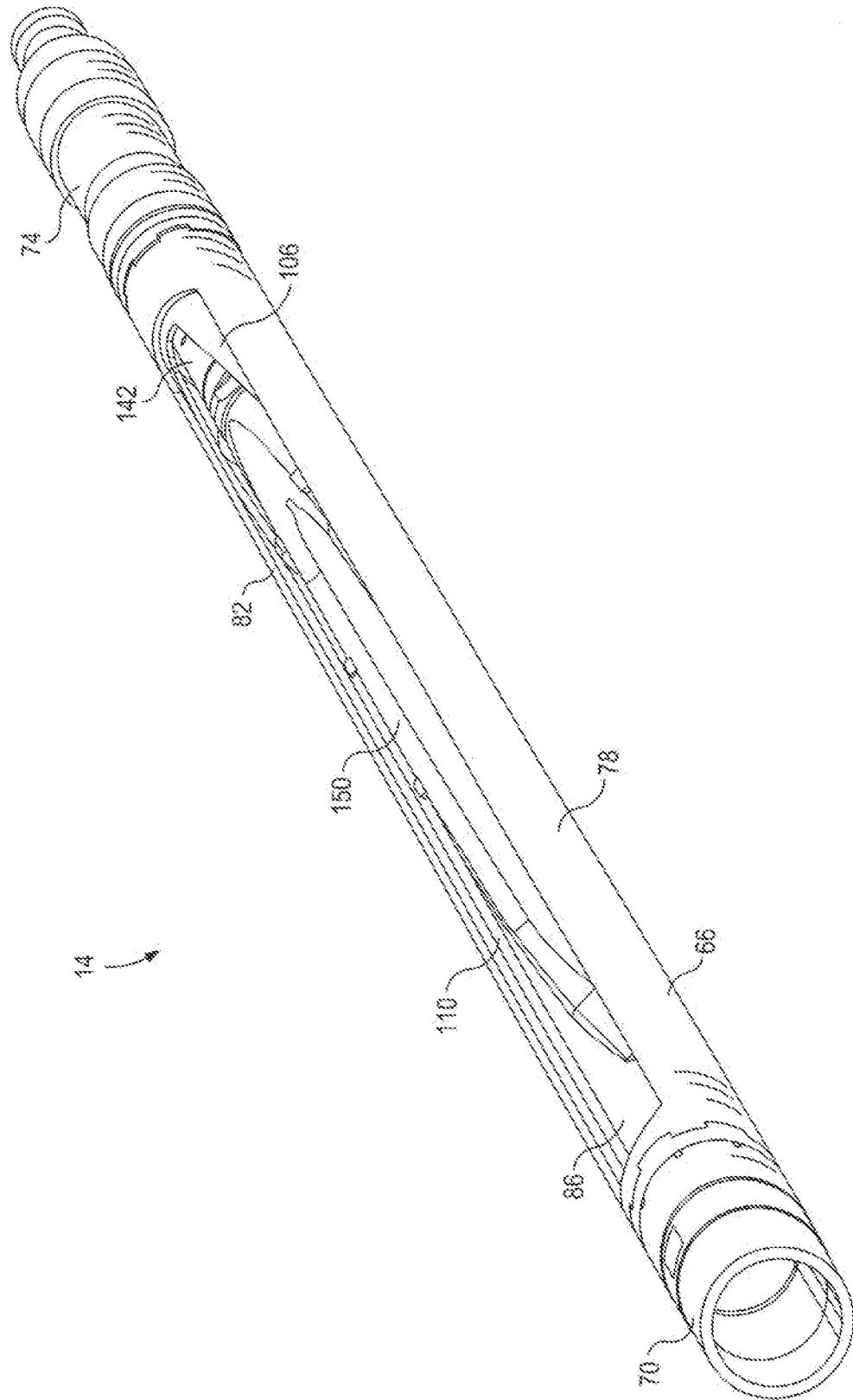

FIG. 13

A. CLASSIFICATION OF SUBJECT MATTER**E21B 7/08(2006.01)i, E21B 29/06(2006.01)i, E21B 7/06(2006.01)i**

According to International Patent Classification (IPC) or to both national classification and IPC

B. FIELDS SEARCHED

Minimum documentation searched (classification system followed by classification symbols)

E21B 7/08; E21B 33/124; E21B 19/00; E21B 7/06; E21B 23/03

Documentation searched other than minimum documentation to the extent that such documents are included in the fields searched

Korean utility models and applications for utility models

Japanese utility models and applications for utility models

Electronic data base consulted during the international search (name of data base and, where practicable, search terms used)

eKOMPASS(KIPO internal) & Keywords: casing, section, window, open, deflector and similar terms

C. DOCUMENTS CONSIDERED TO BE RELEVANT

Category*	Citation of document, with indication, where appropriate, of the relevant passages	Relevant to claim No.
X	US 2009-0255687 A1 (MCCULLOUGH, ROBERT et al.) 15 October 2009	1-3, 6-8, 19
Y	See paragraphs 21-37 and figures 1-5	4, 9-12, 15, 17-18, 20, 21
A		5, 13, 14, 16
Y	US 2003-0196819 A1 (ROBERT, JOE COON) 23 October 2003 See paragraphs 55-57 and figures 8-10	4, 9-12, 15, 17-18, 20, 21
A	US 6899186 B2 (GREGORY G., GALLOWAY et al.) 31 May 2005 See column 6, line 53 - column 7, line 25 and figure 6A, 6B	1-21
A	US 2010-0294512 A1 (ASSAL, ANWAR AHMED MAHER et al.) 25 November 2010 See paragraphs 32, 37 and figure 4, 6	1-21

 Further documents are listed in the continuation of Box C. See patent family annex.

* Special categories of cited documents:

"A" document defining the general state of the art which is not considered to be of particular relevance

"E" earlier application or patent but published on or after the international filing date

"L" document which may throw doubts on priority claim(s) or which is cited to establish the publication date of citation or other special reason (as specified)

"O" document referring to an oral disclosure, use, exhibition or other means

"P" document published prior to the international filing date but later than the priority date claimed

"T" later document published after the international filing date or priority date and not in conflict with the application but cited to understand the principle or theory underlying the invention

"X" document of particular relevance; the claimed invention cannot be considered novel or cannot be considered to involve an inventive step when the document is taken alone

"Y" document of particular relevance; the claimed invention cannot be considered to involve an inventive step when the document is combined with one or more other such documents, such combination being obvious to a person skilled in the art

"&" document member of the same patent family

Date of the actual completion of the international search

06 FEBRUARY 2013 (06.02.2013)

Date of mailing of the international search report

18 FEBRUARY 2013 (18.02.2013)

Name and mailing address of the ISA/KR

Korean Intellectual Property Office
189 Cheongsu-ro, Seo-gu, Daejeon Metropolitan
City, 302-701, Republic of Korea

Facsimile No. 82-42-472-7140

Authorized officer

Bonghoon Lee

Telephone No. 82-42-481-8553



Box No. II Observations where certain claims were found unsearchable (Continuation of item 2 of first sheet)

This international search report has not been established in respect of certain claims under Article 17(2)(a) for the following reasons:

1. Claims Nos.:
because they relate to subject matter not required to be searched by this Authority, namely:

2. Claims Nos.:
because they relate to parts of the international application that do not comply with the prescribed requirements to such an extent that no meaningful international search can be carried out, specifically:

3. Claims Nos.:
because they are dependent claims and are not drafted in accordance with the second and third sentences of Rule 6.4(a).

Box No. III Observations where unity of invention is lacking (Continuation of item 3 of first sheet)

This International Searching Authority found multiple inventions in this international application, as follows:

Group I : Claims 1-8 and 1-21 which are directed to a casing section and method for providing a window in a casing string employing the casing section.

Group II : Claims 9-18 directed to a drilling system.

1. As all required additional search fees were timely paid by the applicant, this international search report covers all searchable claims.
2. As all searchable claims could be searched without effort justifying an additional fee, this Authority did not invite payment of any additional fee.
3. As only some of the required additional search fees were timely paid by the applicant, this international search report covers only those claims for which fees were paid, specifically claims Nos.:

4. No required additional search fees were timely paid by the applicant. Consequently, this international search report is restricted to the invention first mentioned in the claims; it is covered by claims Nos.:

Remark on Protest

- The additional search fees were accompanied by the applicant's protest and, where applicable, the payment of a protest fee.
- The additional search fees were accompanied by the applicant's protest but the applicable protest fee was not paid within the time limit specified in the invitation.
- No protest accompanied the payment of additional search fees.

INTERNATIONAL SEARCH REPORT

Information on patent family members

International application No.

PCT/US2012/035754

Patent document cited in search report	Publication date	Patent family member(s)	Publication date
US 2009-0255687 A1	15. 10. 2009	WO 2009-126413 A2	15. 10. 2009
		WO 2009-126413 A3	18. 03. 2010
US 2003-0196819 A1	23. 10. 2003	CA 2446947 A1	06. 03. 2003
		CA 2446947 C	16. 10. 2007
		GB 0326004 D0	10. 12. 2003
		GB 2392696 A	10. 03. 2004
		GB 2392696 B	11. 05. 2005
		US 2003-0037930 A1	27. 02. 2003
		US 6591905 B2	15. 07. 2003
		US 6968896 B2	29. 11. 2005
		WO 03-018953 A1	06. 03. 2003
		US 6899186 B2	31. 05. 2005
AU 2001-44377 A1	30. 10. 2001		
AU 2003-249651 A1	12. 12. 2003		
CA 2362209 A1	31. 08. 2000		
CA 2362209 C	10. 07. 2007		
CA 2406083 A1	25. 10. 2001		
CA 2406083 C	03. 10. 2006		
CA 2444555 A1	11. 04. 2004		
CA 2444555 C	08. 04. 2008		
CA 2452903 A1	13. 06. 2004		
CA 2452903 C	03. 11. 2009		
CA 2453459 A1	20. 06. 2004		
CA 2453459 C	12. 06. 2007		
CA 2453768 A1	30. 06. 2004		
CA 2453768 C	14. 08. 2007		
CA 2464999 A1	21. 10. 2004		
CA 2464999 C	12. 08. 2008		
CA 2468602 A1	01. 03. 2005		
CA 2487100 A1	04. 12. 2003		
CA 2487100 C	29. 07. 2008		
CA 2512641 A1	19. 08. 2004		
CA 2512641 C	05. 04. 2011		
CA 2514776 A1	04. 02. 2006		
CA 2514776 C	07. 10. 2008		
CA 2515296 A1	26. 08. 2004		
CA 2515296 C	21. 09. 2010		
CA 2538196 A1	28. 08. 2006		
CA 2538196 C	11. 10. 2011		
CA 2539266 A1	20. 04. 2007		
CA 2539266 C	11. 10. 2011		
CA 2547481 A1	20. 11. 2006		
CA 2547481 C	15. 11. 2011		
CA 2585476 A1	30. 06. 2004		
CA 2585476 C	20. 04. 2010		
CA 2600602 A1	07. 03. 2008		
CA 2633627 A1	04. 02. 2006		

INTERNATIONAL SEARCH REPORT

Information on patent family members

International application No.

PCT/US2012/035754

Patent document cited in search report	Publication date	Patent family member(s)	Publication date
		CA 2633627 C	08.06.2010
		CA 2640104 A1	13.06.2004
		CA 2708591 A1	26.08.2004
		CA 2725717 A1	19.08.2004
		CA 2750697 A1	20.11.2006
		CA 2760504 A1	26.08.2004
		EP 1155216 A1	21.11.2001
		EP 1155216 B1	12.01.2005
		EP 1272731 A1	08.01.2003
		EP 1272731 B1	29.11.2006
		EP 1588015 A2	26.10.2005
		EP 1898044 A2	12.03.2008
		EP 1898044 A3	28.05.2008
		EP 2278111 A2	26.01.2011
		EP 2278112 A2	26.01.2011
		EP 2278113 A2	26.01.2011
		EP 2278114 A2	26.01.2011
		GB 0328864 D0	14.01.2004
		GB 2382361 A	28.05.2003
		GB 2397314 A	21.07.2004
		GB 2397314 B	05.04.2006
		GB 2401618 A	17.11.2004
		GB 2403747 A	12.01.2005
		GB 2406116 A	23.03.2005
		GB 2415451 A	28.12.2005
		GB 2416793 A	08.02.2006
		GB 2423104 A	16.08.2006
		GB 2424432 A	27.09.2006
		GB 2426271 A	22.11.2006
		GB 2427662 A	03.01.2007
		GB 2428722 A	07.02.2007
		GB 2430951 A	11.04.2007
		GB 2431942 A	09.05.2007
		GB 2437863 A	07.11.2007
		US 2003-0146001 A1	07.08.2003
		US 2003-0164250 A1	04.09.2003
		US 2004-0031622 A1	19.02.2004
		US 2004-0069501 A1	15.04.2004
		US 2004-0112603 A1	17.06.2004
		US 2004-0118614 A1	24.06.2004
		US 2004-0124010 A1	01.07.2004
		US 2004-0188145 A1	30.09.2004
		US 2004-0206511 A1	21.10.2004
		US 2004-0221997 A1	11.11.2004
		US 2004-0245020 A1	09.12.2004
		US 2004-0262013 A1	30.12.2004
		US 2005-0045337 A1	03.03.2005
		US 2005-0045340 A1	03.03.2005
		US 2005-0045382 A1	03.03.2005
		US 2005-0133274 A1	23.06.2005

INTERNATIONAL SEARCH REPORT

Information on patent family members

International application No.

PCT/US2012/035754

Patent document cited in search report	Publication date	Patent family member(s)	Publication date
		US 2005-0205250 A1	22.09.2005
		US 2005-0217858 A1	06.10.2005
		US 2006-0005999 A1	12.01.2006
		US 2006-0157282 A1	20.07.2006
		US 2006-0185855 A1	24.08.2006
		US 2006-0196695 A1	07.09.2006
		US 2007-0056774 A9	15.03.2007
		US 2007-0068705 A1	29.03.2007
		US 2007-0089910 A1	26.04.2007
		US 2007-0119626 A9	31.05.2007
		US 2008-0060846 A1	13.03.2008
		US 2008-0093124 A1	24.04.2008
		US 2008-0110673 A1	15.05.2008
		US 2008-0128140 A1	05.06.2008
		US 2008-0257605 A1	23.10.2008
		US 2010-0139978 A9	10.06.2010
		US 2011-0011646 A1	20.01.2011
		US 2011-0114387 A1	19.05.2011
		US 2012-0031678 A1	09.02.2012
		US 2012-0043135 A1	23.02.2012
		US 2012-0138298 A1	07.06.2012
		US 6719071 B1	13.04.2004
		US 6837313 B2	04.01.2005
		US 6848517 B2	01.02.2005
		US 6854533 B2	15.02.2005
		US 6857487 B2	22.02.2005
		US 6896075 B2	24.05.2005
		US 6966367 B2	22.11.2005
		US 6968911 B2	29.11.2005
		US 7066247 B2	27.06.2006
		US 7083005 B2	01.08.2006
		US 7090023 B2	15.08.2006
		US 7111692 B2	26.09.2006
		US 7131505 B2	07.11.2006
		US 7303022 B2	04.12.2007
		US 7306042 B2	11.12.2007
		US 7311148 B2	25.12.2007
		US 7334650 B2	26.02.2008
		US 7395877 B2	08.07.2008
		US 7730965 B2	08.06.2010
		US 7823660 B2	02.11.2010
		US 7836973 B2	23.11.2010
		US 7938201 B2	10.05.2011
		US 8042616 B2	25.10.2011
		US 8066069 B2	29.11.2011
		US 8122975 B2	28.02.2012
		US 8127868 B2	06.03.2012
		WO 00-50731 A1	31.08.2000
		WO 01-79650 A1	25.10.2001
		WO 03-100208 A1	04.12.2003

INTERNATIONAL SEARCH REPORT

Information on patent family members

International application No.

PCT/US2012/035754

Patent document cited in search report	Publication date	Patent family member(s)	Publication date
		WO 2004-070159 A2	19.08.2004
		WO 2004-070159 A3	19.08.2004
		WO 2004-072434 A2	26.08.2004
		WO 2004-072434 A3	26.08.2004
US 2010-0294512 A1	25.11.2010	GB 201119733 D0	28.12.2011
		GB 2482458 A	01.02.2012
		US 8286708 B2	16.10.2012
		WO 2010-135376 A1	25.11.2010